

FAR & Tenement Details (Table 4c-1)

Building	No. of Same Bldg	Total Built Up Area (Sq.mt.)	Deductions (Area in Sq.mt.) Parking	Proposed FAR Area (Sq.mt.) Resi.	Add Area In FAR (Sq.mt.) Stair	Total FAR Area (Sq.mt.)	Total Consumed Additional FAR Area (Sq.mt.)	Tnmt (No.)
A (SMT SARJEET KAUR)	1	142.53	31.28	96.12	15.13	111.25	111.25	01
<b>Grand Total :</b>	<b>1</b>	<b>142.53</b>	<b>31.28</b>	<b>96.12</b>	<b>15.13</b>	<b>111.25</b>	<b>111.25</b>	<b>01</b>

Proposal Basic Information

Proposal File No.	JNAC/BP/0059/W11/2018
Owner Name	Smt. Sarjeet Kaur
Khata No	Nil
Plot No	Holding No.-202
Village Name	GOLMURI
Use	Residential
SubUse	Bungalow/ Dwelling / Non Apartment

AREA STATEMENT JAMSHEDPUR NAC	VERSION NO : 1.0.37 VERSION DATE: 29/04/2019
<b>PROJECT DETAIL:</b>	
Region: JHARKHAND URBAN LOCAL BODIES	Plot Use: Residential
District: EAST SINGHBHUM	Plot SubUse: Bungalow/ Dwelling / Non Apartment
Authority: JAMSHEDPUR NAC	PlotNearby/ReligiousStructure: NA
Inward_No: JNAC/BP/0059/W11/2018	PlotSubPlot No: Holding No.-202
Application Type: General Proposal	North: Survey No. - Alley
Project Type: Building Permission	South: Road Width - 9
Nature of Development: New	East: Plot No. - 201
Location of Development Area: Old Area	West: Plot No. - 203
<b>AREA DETAILS:</b>	
AREA OF PLOT (Minimum)	(A) 83.31
Deduction for NetPlot Area	
Road Widening Area	4.81
Total	4.81
NET AREA OF PLOT(Gross Plot Area - Deduction from Gross Plot area)	
(A-Deductions)	78.50
Deduction for Balance Plot Area(from Gross Plot Area)	
Road Widening Area	4.81
Common Plot	18.26
Total	23.07
BALANCE AREA OF PLOT(Net Plot Area - Recreational/Amenity space)	
(A-Deductions)	60.24
PLOT AREA FOR COVERAGE(Net Plot Area)	
(A-Deductions)	78.50
Plot Area for FAR (Net Plot Area + RoadWidening Area)	
(A-Deductions)	78.50
<b>COVERAGE CHECK</b>	
Permissible Coverage area ( 70.00 % )	54.95
Proposed Coverage Area ( 59.11 % )	46.40
Total Prop. Coverage Area ( 59.11 % )	46.40
Balance coverage area ( 10.89 % )	8.55
<b>FAR CHECK</b>	
Perm. FAR Area ( 1.50 )	117.75
Total Perm. FAR area	117.75
Residential FAR	96.12
Proposed FAR Area	111.25
Total Proposed FAR Area	111.25
Consumed FAR (Factor)	1.42
Balance FAR Area	6.50
<b>BUILT UP AREA CHECK</b>	
Total Proposed BuiltUp Area	142.53
ARCHITECT (Regd)	L K Suman
ENGINEER (Regd)	
SUPERVISOR (Regd)	
OWNER (Regd)	Smt. Sarjeet Kaur
DEVELOPMENT AUTHORITY LOCAL BODY	

COLOR INDEX	
PLOT BOUNDARY	Black
ABUTTING ROAD	Green
PROPOSED CONSTRUCTION	Red
COMMON PLOT	Yellow
ROAD WIDENING AREA	Orange
EXISTING (To be retained)	Blue
EXISTING (To be demolished)	Light Blue

Buildingwise Floor FAR Details

Floor Name	Building Name A (SMT SARJEET KAUR)		Total	
	Proposed Built Up Area (Sq.mt.)	Proposed FAR Area (Sq.mt.)	Total Proposed Built Up Area (Sq.mt.)	Total FAR Area (Sq.mt.)
Parking Floor	46.41	15.13	46.41	15.13
First Floor	48.06	48.06	48.06	48.06
Second Floor	48.06	48.06	48.06	48.06
Terrace Floor	0.00	0.00	0.00	0.00
<b>Total :</b>	<b>142.53</b>	<b>111.25</b>	<b>142.53</b>	<b>111.25</b>

Building USE/SUBUSE Details

Building Name	Building Use	Building SubUse	Building Structure
A (SMT SARJEET KAUR)	Residential	Bungalow/ Dwelling / Non Apartment	Non-Highrise

LTP NAME AND SIGNATURE	STRUCTURAL ENG'S NAME AND SIGNATURE	BUILDER NAME AND SIGNATURE	DIGITAL SIGNATURE
L K Suman JNAC/ENG/0006/2016			

Proposal Basic Information	
Proposal File No.	JNAC/BP/0059/W11/2018
Owner Name	Smt. Sarjeet Kaur
Khata No	Nil
Plot No	Holding No.-202
Village Name	GOLMURI
Use	Residential
SubUse	Bungalow/ Dwelling / Non Apartment

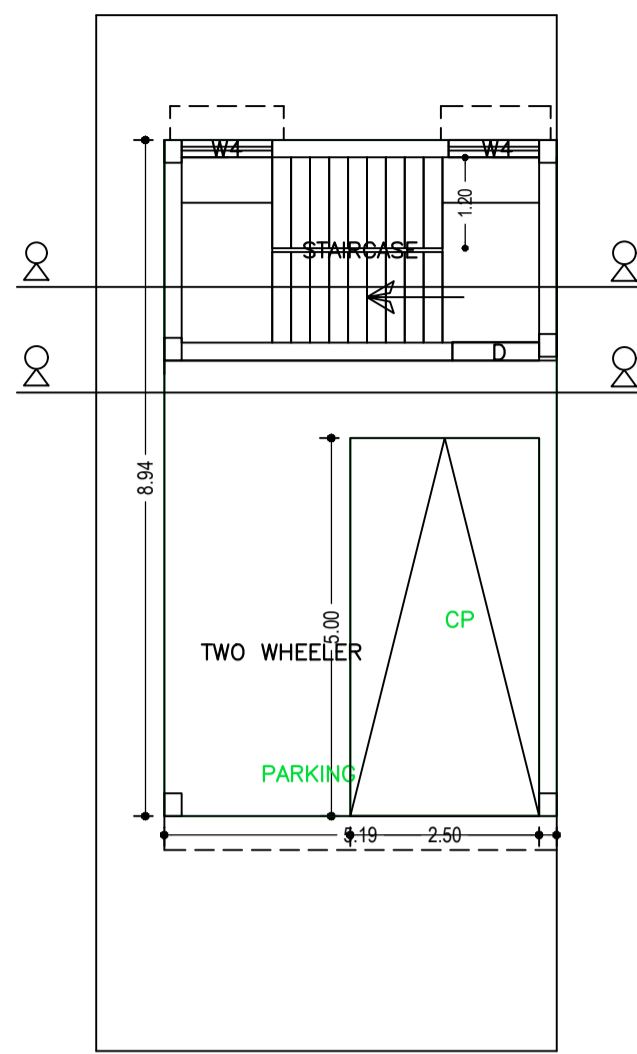

PARKING FLOOR PLAN (SCALE 1:100)

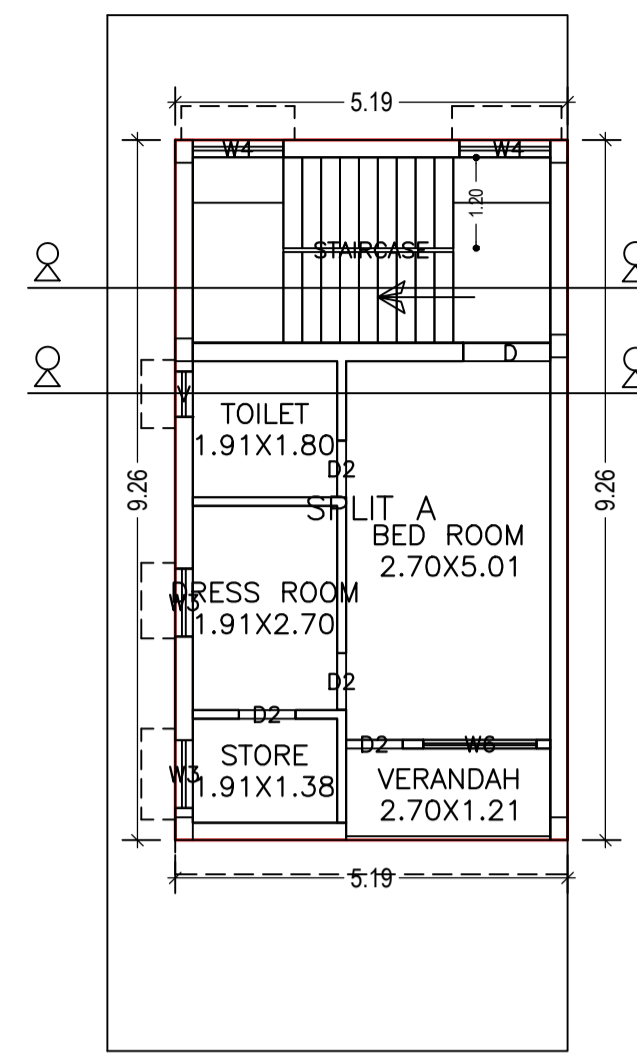

SECOND FLOOR PLAN (Proposed) (SCALE 1:100)

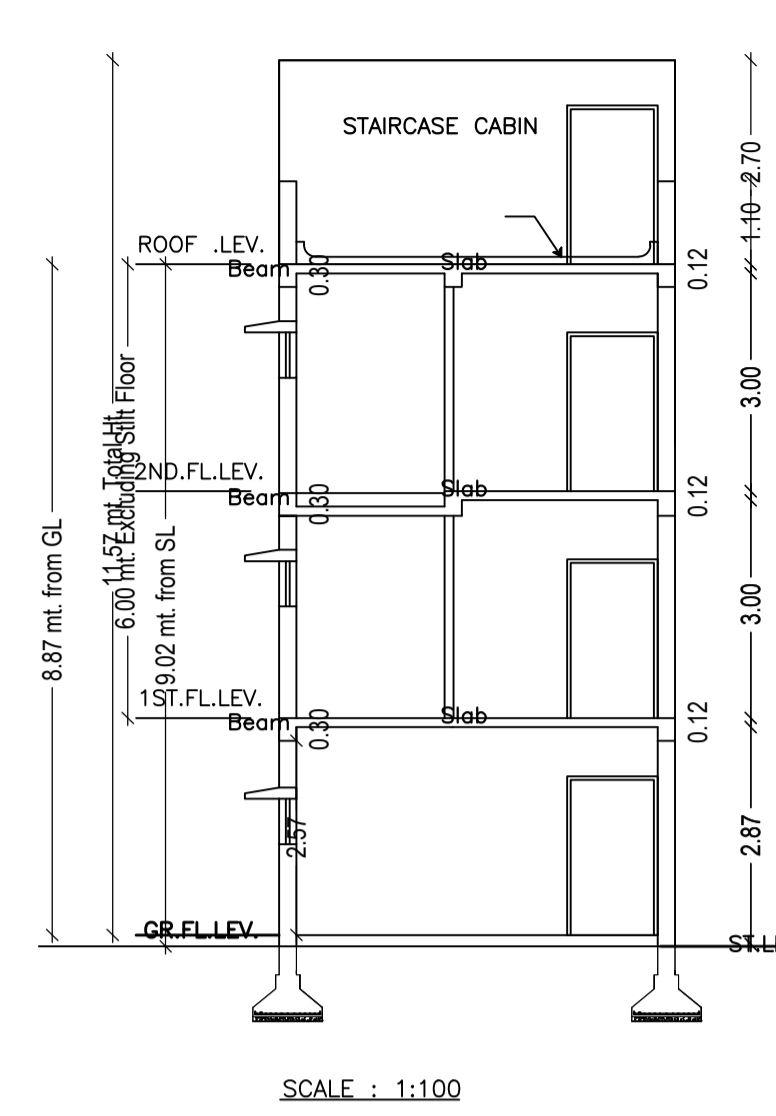
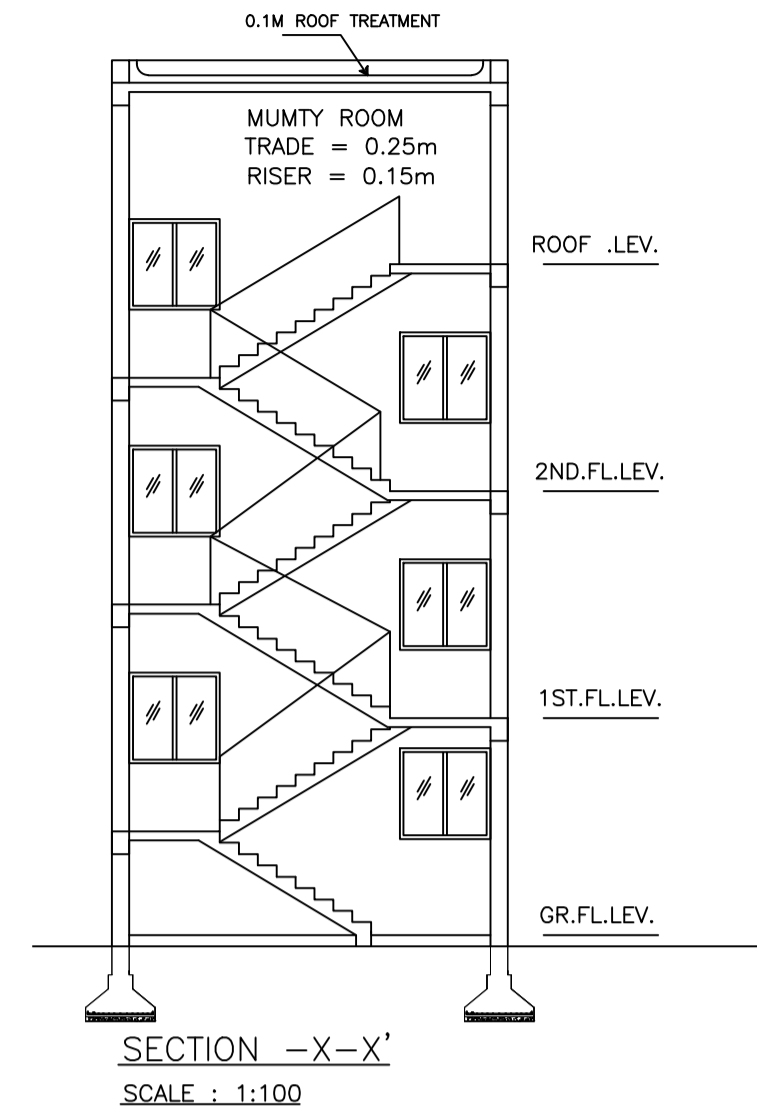

SCALE : 1:100

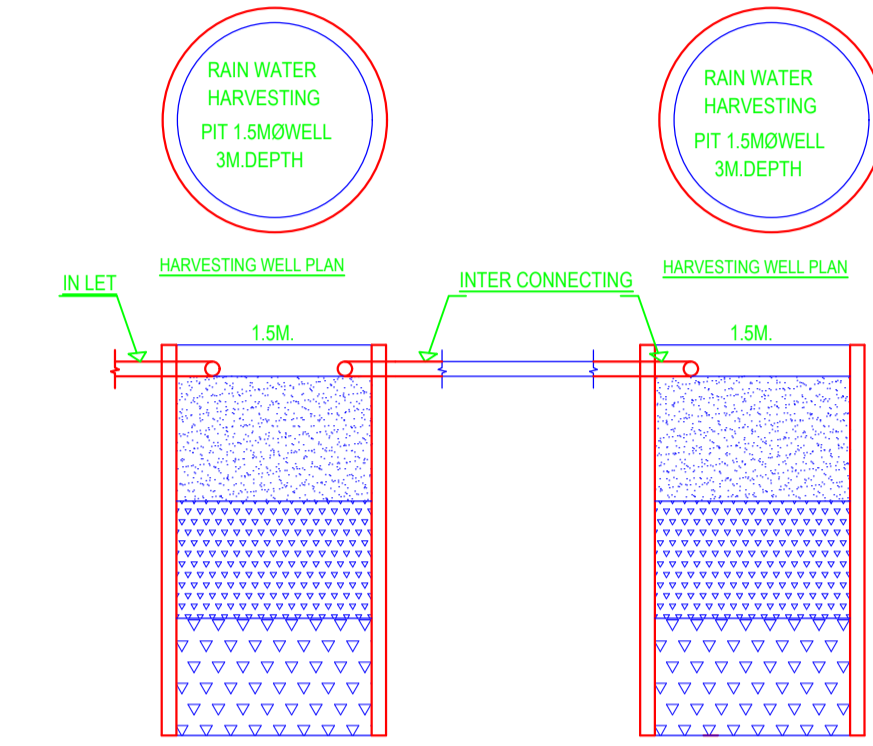

HARVESTING WELL SECTION

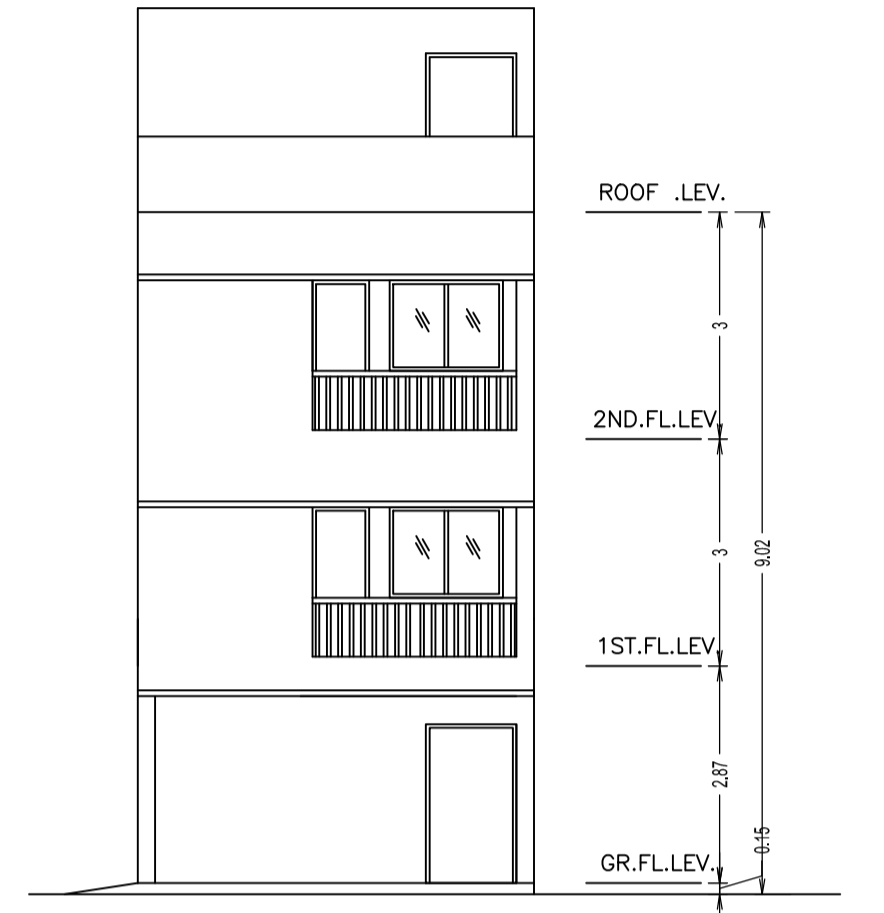

FRONT ELEVATION (SCALE 1:100)

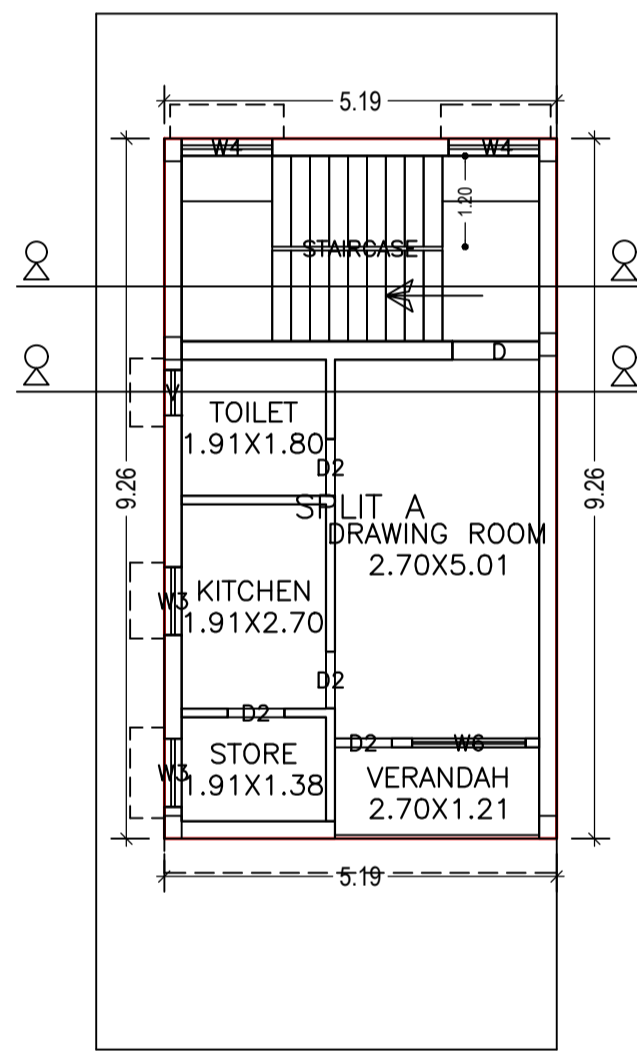

FIRST FLOOR PLAN (Proposed) (SCALE 1:100)

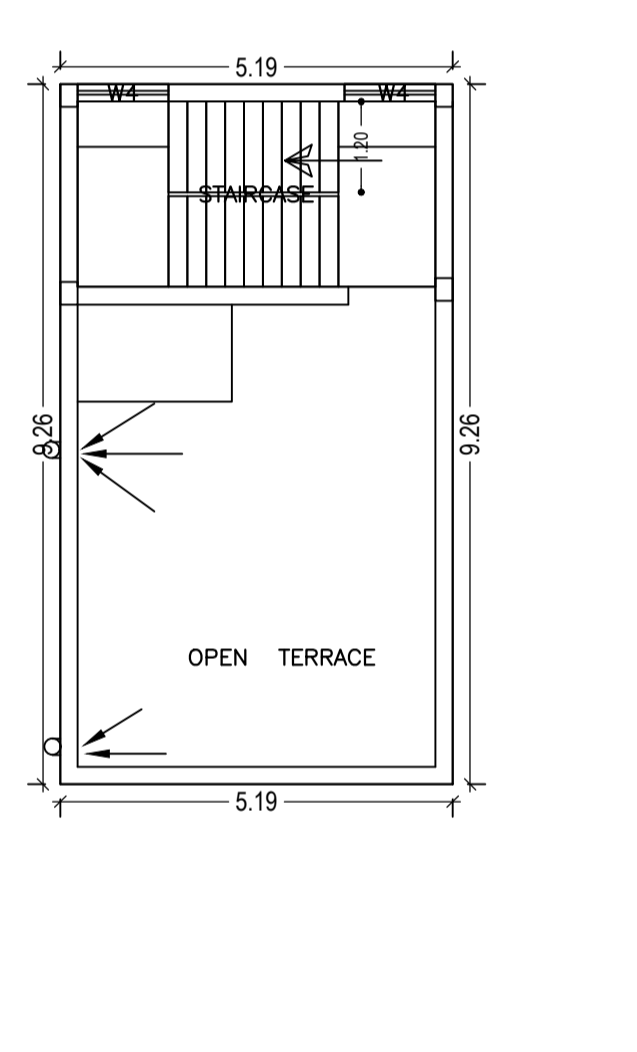

TERRACE FLOOR PLAN (SCALE 1:100)

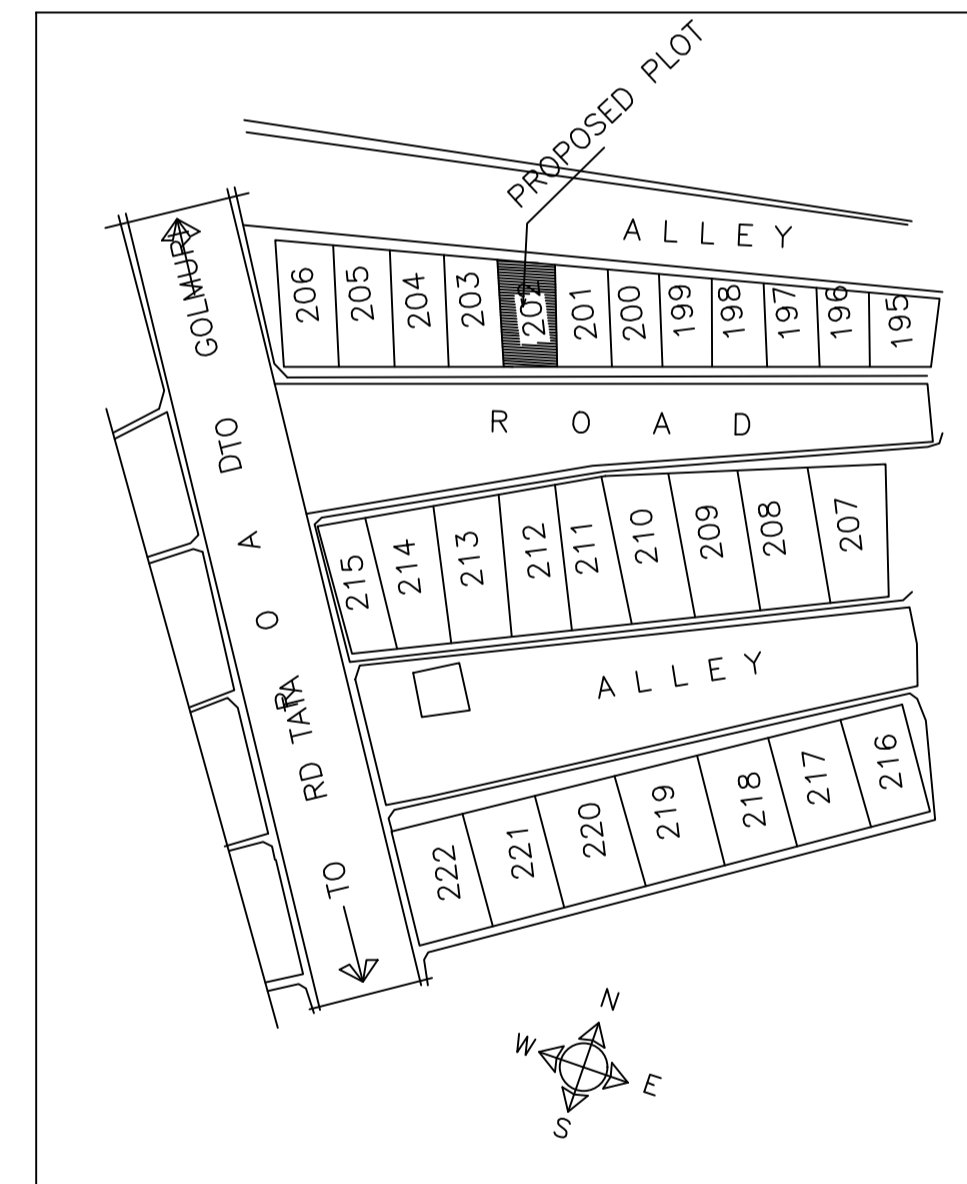

PART SITE PLAN OF TULADUNGR (SCALE : NTS)

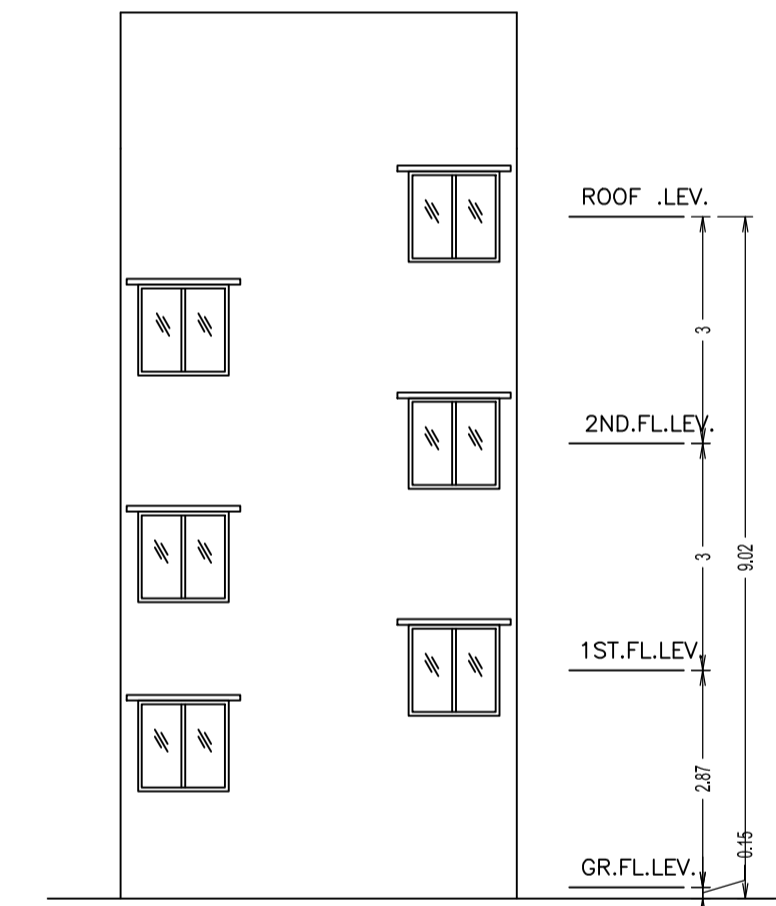

REAR ELEVATION (SCALE 1:100)

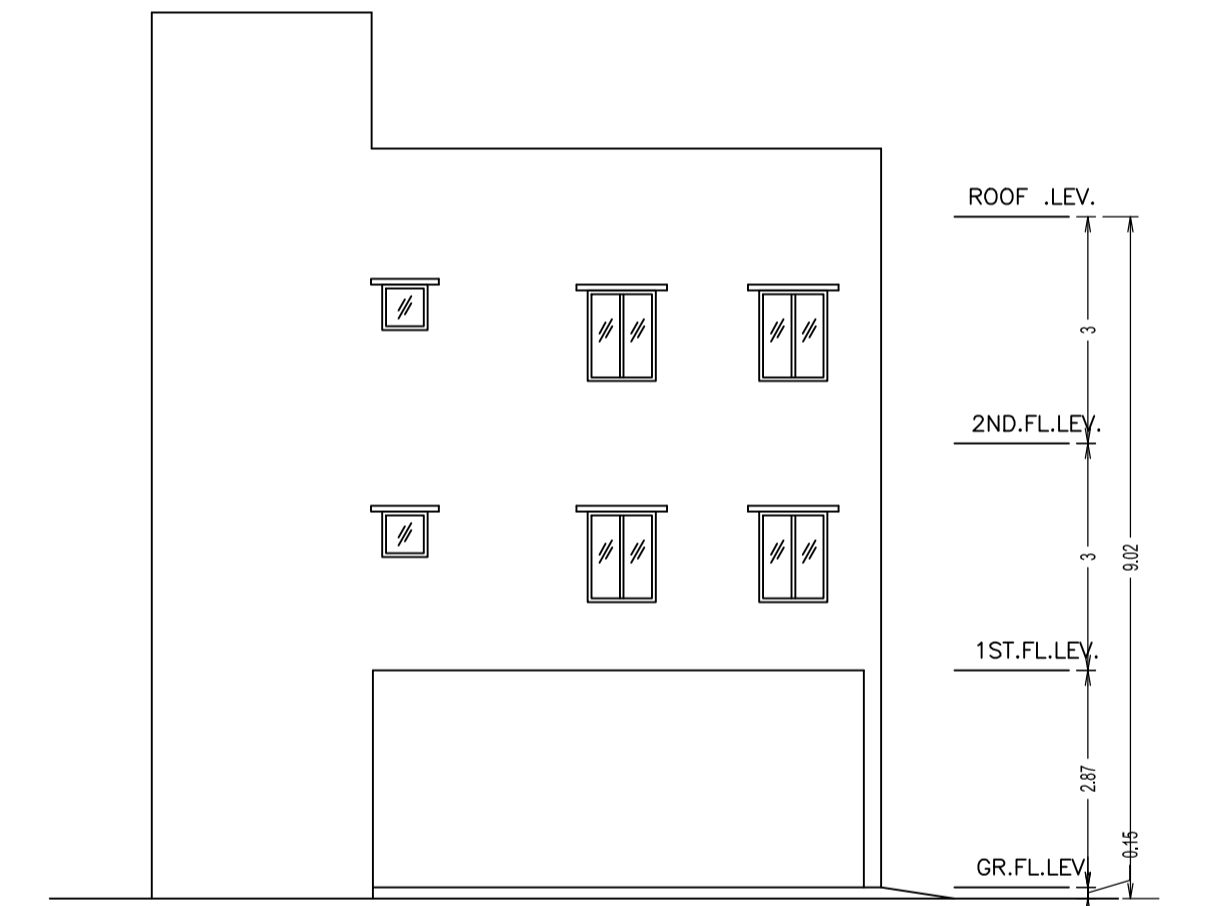

SIDE ELEVATION (SCALE 1:100)

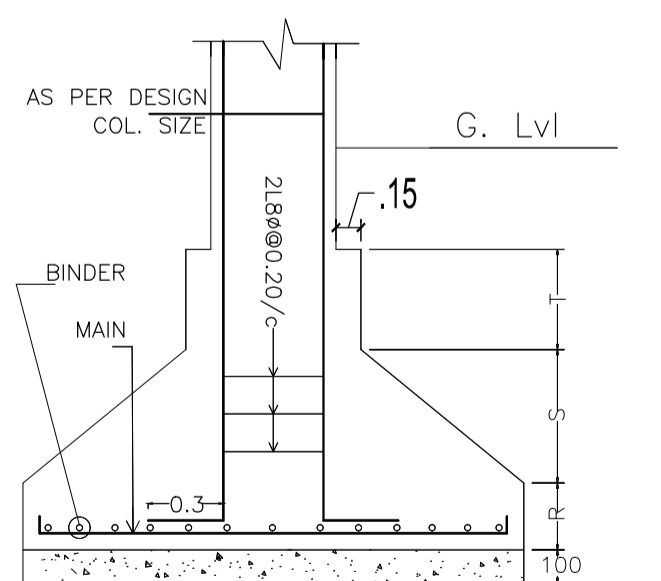

DETAIL OF COLUMN & FOOTING

Building :A (SMT SARJEET KAUR)

Floor Name	Total Built Up Area (Sq.mt.)	Deductions (Area in Sq.mt.)		Proposed FAR Area (Sq.mt.)		Total FAR Area (Sq.mt.)	Total Consumed Additional FAR Area (Sq.mt.)	Trmt (No.)
		Parking	Resi.	Stair	Stair			
Parking Floor	46.41	31.28	0.00	15.13	15.13	15.13	00	
First Floor	48.06	0.00	48.06	0.00	48.06	48.06	01	
Second Floor	48.06	0.00	48.06	0.00	48.06	48.06	00	
Terrace Floor	0.00	0.00	0.00	0.00	0.00	0.00	00	
Total :	142.53	31.28	96.12	15.13	111.25	111.25	01	
Total Number of Same Buildings	1							
Total :	142.53	31.28	96.12	15.13	111.25	111.25	01	

SCHEDULE OF DOOR:

BUILDING NAME	NAME	LENGTH	HEIGHT	NOS
A (SMT SARJEET KAUR)	D2	0.75	2.10	08
A (SMT SARJEET KAUR)	D	1.15	2.10	02

SCHEDULE OF WINDOW/VENTILATION:

BUILDING NAME	NAME	LENGTH	HEIGHT	NOS
A (SMT SARJEET KAUR)	V	0.60	0.60	02
A (SMT SARJEET KAUR)	W3	0.90	1.20	04
A (SMT SARJEET KAUR)	W4	1.20	1.20	08
A (SMT SARJEET KAUR)	W6	1.50	1.20	02

UnitBUA Table for Building :A (SMT SARJEET KAUR)

FLOOR	Name	UnitBUA Type	UnitBUA Area	Carpet Area	No. of Rooms	No. of Tenement
FIRST FLOOR PLAN	SPLIT A	FLAT	84.49	80.82	5	1
SECOND FLOOR PLAN	SPLIT A	FLAT	0.00	0.00	5	0
Total:	-	-	84.49	80.82	10	1

LTP NAME AND SIGNATURE	STRUCTURAL ENG'S NAME AND SIGNATURE	BUILDER NAME AND SIGNATURE	DIGITAL SIGNATURE
L K Suman JNAC/ENG/0006/2016			