

SCHEDULE OF DOOR:

BUILDING NAME	NAME	LENGTH	HEIGHT	NOS
A (SHOVNAN TOPPO RESIDENCE)	D2	0.76	2.10	02
A (SHOVNAN TOPPO RESIDENCE)	D1	0.91	2.10	04
A (SHOVNAN TOPPO RESIDENCE)	D	1.20	2.10	02

SCHEDULE OF WINDOW/VENTILATION:

BUILDING NAME	NAME	LENGTH	HEIGHT	NOS
A (SHOVNAN TOPPO RESIDENCE)	V	0.61	0.61	02
A (SHOVNAN TOPPO RESIDENCE)	W1	1.50	1.20	08
A (SHOVNAN TOPPO RESIDENCE)	WK	1.80	1.00	02
A (SHOVNAN TOPPO RESIDENCE)	W	1.80	1.20	06

Building :A (SHOVNAN TOPPO RESIDENCE)

Floor Name	Total Built Up Area (Sq.mt.)	Deductions (Area in Sq.mt.)		Proposed FAR Area (Sq.mt.)	Add Area In FAR (Sq.mt.)	Total FAR Area (Sq.mt.)	Total Consumed Additional FAR Area (Sq.mt.)	Tnmt (No.)
		Accessory Use	Parking					
Ground Floor	83.40	3.69	59.54	0.00	20.17	20.17	20.17	00
First Floor	83.40	0.00	0.00	83.40	0.00	83.40	83.40	01
Second Floor	83.40	0.00	0.00	83.40	0.00	83.40	83.40	00
Terrace Floor	0.00	0.00	0.00	0.00	0.00	0.00	0.00	00
Total :	250.20	3.69	59.54	166.80	20.17	186.97	186.97	01
Total Number of Same Buildings :	1							
Total :	250.20	3.69	59.54	166.80	20.17	186.97	186.97	01

FAR & Tenement Details (Table 4c-1)

Building	No. of Same Bldg	Total Built Up Area (Sq.mt.)	Deductions (Area in Sq.mt.)		Proposed FAR Area (Sq.mt.)	Add Area In FAR (Sq.mt.)	Total FAR Area (Sq.mt.)	Total Consumed Additional FAR Area (Sq.mt.)	Tnmt (No.)
			Accessory Use	Parking					
A (SHOVNAN TOPPO RESIDENCE)	1	250.20	3.69	59.54	166.80	20.17	186.97	186.97	01
Grand Total	1	250.20	3.69	59.54	166.80	20.17	186.97	186.97	01

Building USE/SUBUSE Details

Building Name	Building Use	Building SubUse	Building Structure
A (SHOVNAN TOPPO RESIDENCE)	Residential	Residential Bldg/Apartment	Non-Highrise

UnitBUA Table for Building :A (SHOVNAN TOPPO RESIDENCE)

FLOOR	Name	UnitBUA Type	UnitBUA Area	Carpet Area	No. of Rooms	No. of Tenement
FIRST FLOOR PLAN	SPLIT UNIT 1	FLAT	150.49	41.97	4	1
SECOND FLOOR PLAN	SPLIT UNIT 1	FLAT	0.00	0.00	4	0
Total:	-	-	150.49	41.97	8	1

Proposal Basic Information

Proposal File No.	JNAC/BP/0058/W1/2018
Owner Name	SRI SHOVNAN TOPPO
Khata No	NIL
Plot No	NIL
Village Name	SONARI
Use	Residential
SubUse	Residential Bldg/Apartment

AREA STATEMENT		VERSION NO. : 1.0.28
JAMSHEDPUR NAC		VERSION DATE: 30/06/2018
PROJECT DETAIL:		
Region: JHARKHAND URBAN	Plot Use: Residential	
Local Bodies: EAST SINGHBHUM	Plot SubUse: Residential Bldg/Apartment	
Authority: JAMSHEDPUR NAC	Plot/Nearby/ReligiousStructure: NA	
Inward No: JNAC/BP/0058/W1/2018	Plot/SubPlot No: NIL	
Application Type: General Proposal	North: -	
Project Type: Building Permission	South: -	
Nature of Development: New	East: -	
Location of Development Area: Old Area	West: -	
AREA DETAILS:		
AREA OF PLOT (Minimum)	(A)	SQ.MT. 125.60
NET AREA OF PLOT (Gross Plot Area - Deduction from Gross Plot area)	(A-Deductions)	125.60
Deduction for Balance Plot Area (from Gross Plot Area)		
Common Plot		42.20
BALANCE AREA OF PLOT (Net Plot Area - Recreational/Amenity space)	(A-Deductions)	83.39
PLOT AREA FOR COVERAGE (Net Plot Area)	(A-Deductions)	125.60
Plot Area for FAR (Net Plot Area + Road Widening Area)	(A-Deductions)	125.60
COVERAGE CHECK		
Permissible Coverage area (70.00 %)		87.92
Proposed Coverage Area (66.40 %)		83.40
Total Prop. Coverage Area (66.4 %)		83.40
Balance coverage area (3.60 %)		4.52
FAR CHECK		
Perm. FAR Area (2.50)		314.00
Total Perm. FAR area		314.00
Residential FAR		166.79
Proposed FAR Area		186.96
Total Proposed FAR Area		186.96
Consumed FAR (Factor)		1.49
Balance FAR Area		127.04
BUILT UP AREA CHECK		
Total Proposed BuiltUp Area		250.20
ARCHITECT (Regd)	LAWRENCE FRANCIS	
ENGINEER (Regd)		
SUPERVISOR (Regd)		
OWNER (Regd)	SRI SHOVNAN TOPPO	
DEVELOPMENT AUTHORITY		LOCAL BODY

COLOR INDEX	
PLOT BOUNDARY	Black
ABUTTING ROAD	Green
PROPOSED CONSTRUCTION	Red
COMMON PLOT	Yellow
ROAD WIDENING AREA	Blue
EXISTING (To be retained)	Orange
EXISTING (To be demolished)	Grey

Buildingwise Floor FAR Details

Floor Name	Building Name		Total	
	A (SHOVNAN TOPPO RESIDENCE)	Proposed FAR Area (Sq.mt.)	Total Proposed Built Up Area (Sq.mt.)	Total FAR Area (Sq.mt.)
Ground Floor	83.40	20.17	83.40	20.17
First Floor	83.40	83.40	83.40	83.40
Second Floor	83.40	83.40	83.40	83.40
Terrace Floor	0.00	0.00	0.00	0.00
Total :	250.20	186.97	250.20	186.97

LTP NAME AND SIGNATURE	STRUCTURAL ENG'S NAME AND SIGNATURE	BUILDER NAME AND SIGNATURE
LAWRENCE FRANCIS JNAC/ARC/0003/2016		

Proposal Basic Information	
Proposal File No.	JNAC/BP/0058/W1/2018
Owner Name	SRI SHOVNAN TOPPO
Khata No	NIL
Plot No	NIL
Village Name	SONARI
Use	Residential
SubUse	Residential Bldg/Apartment

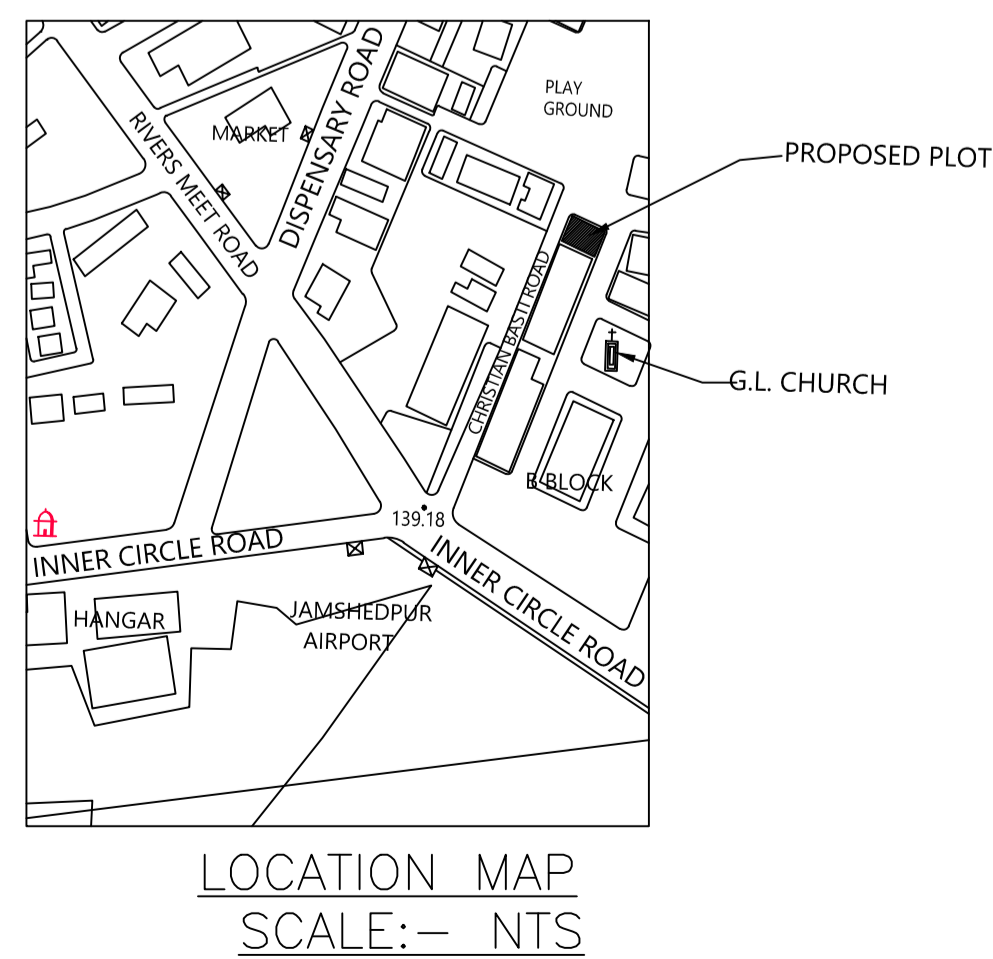
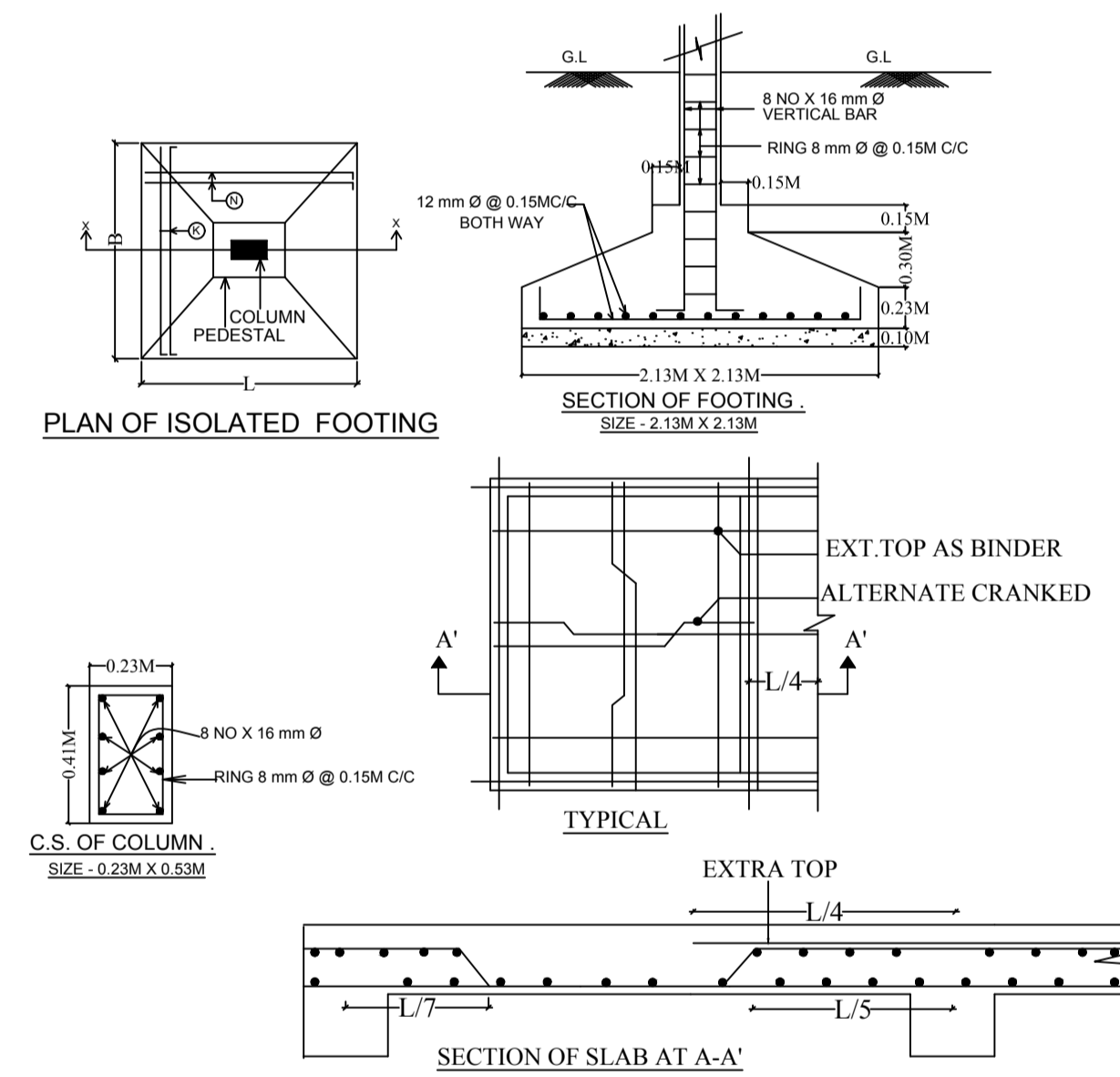
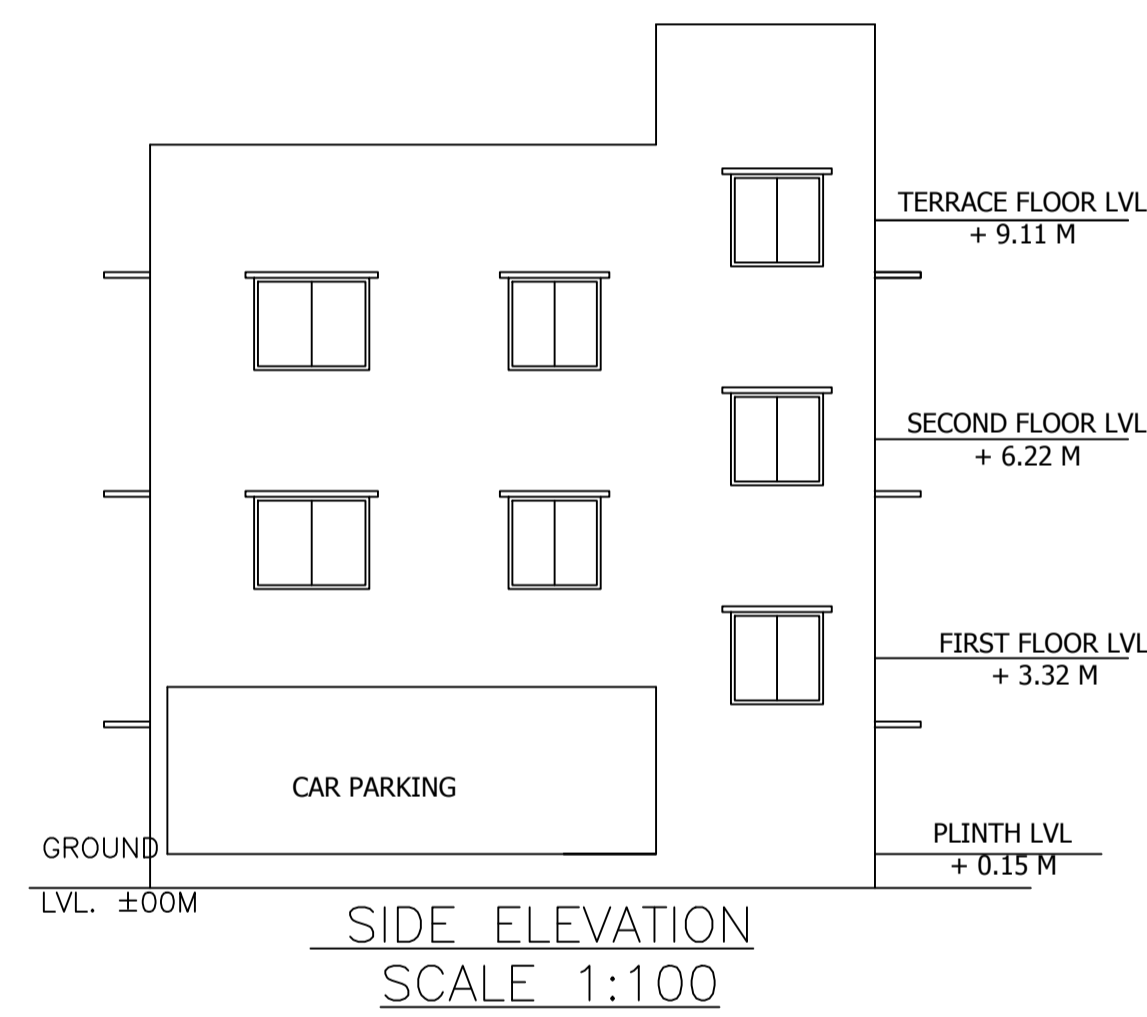
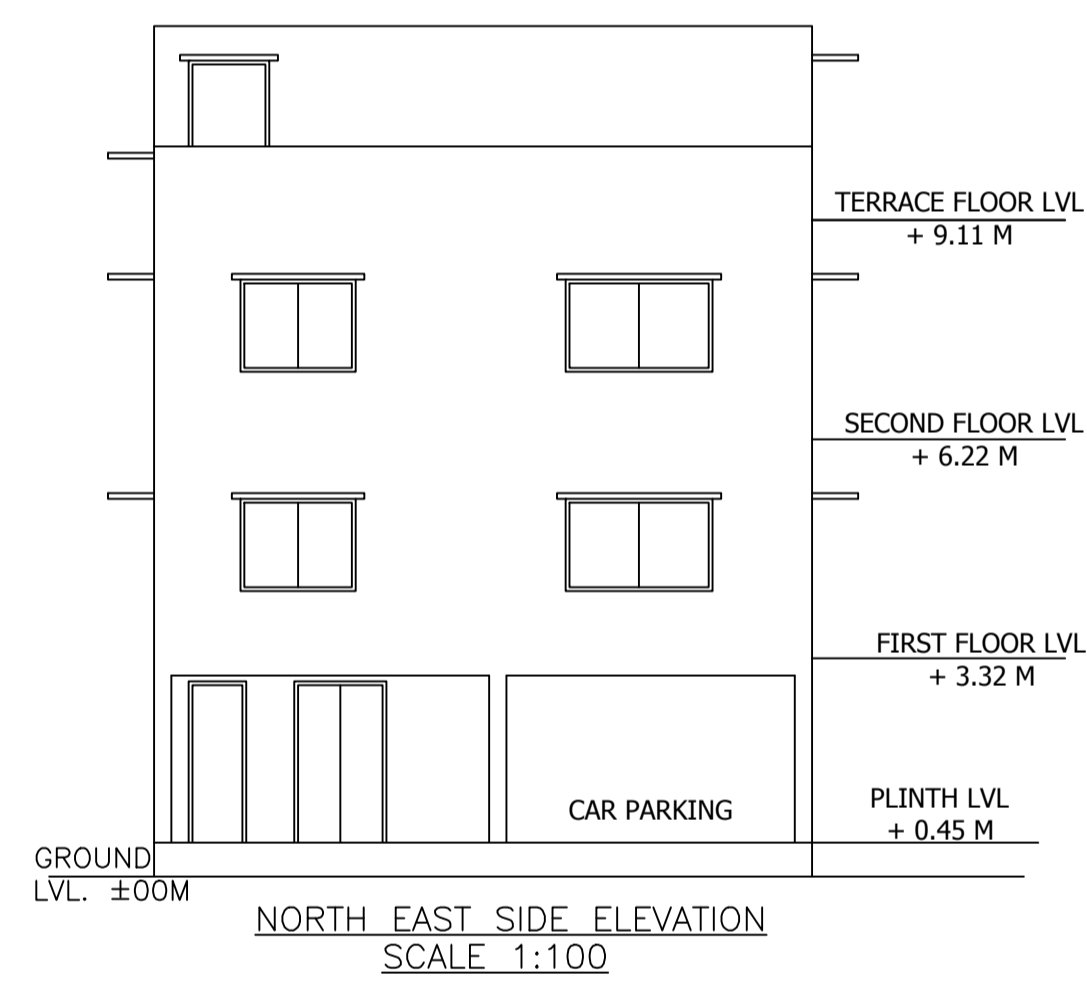
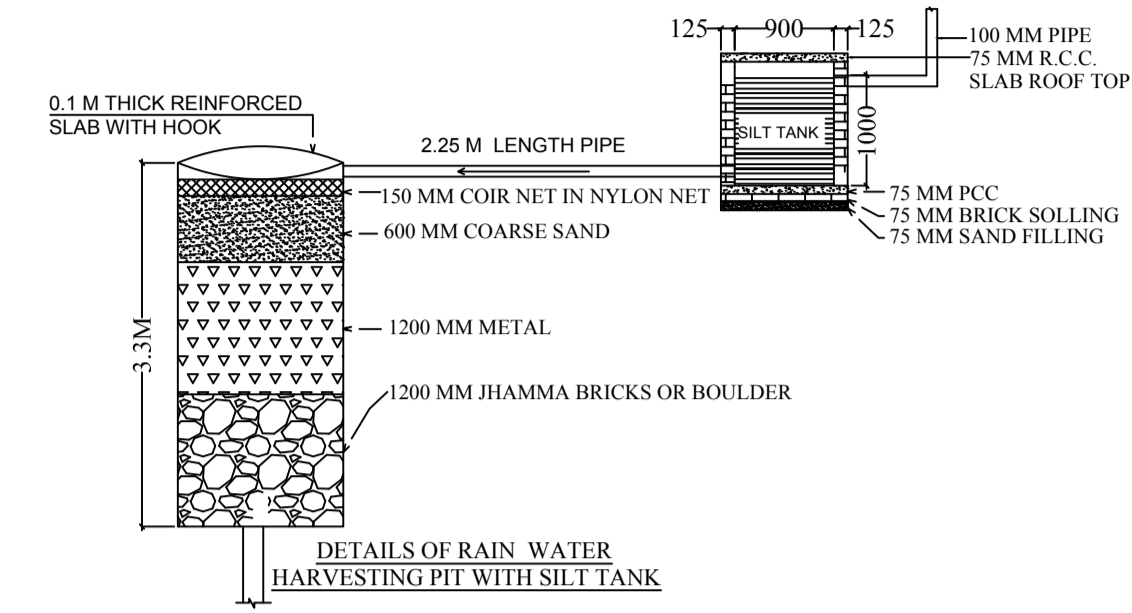
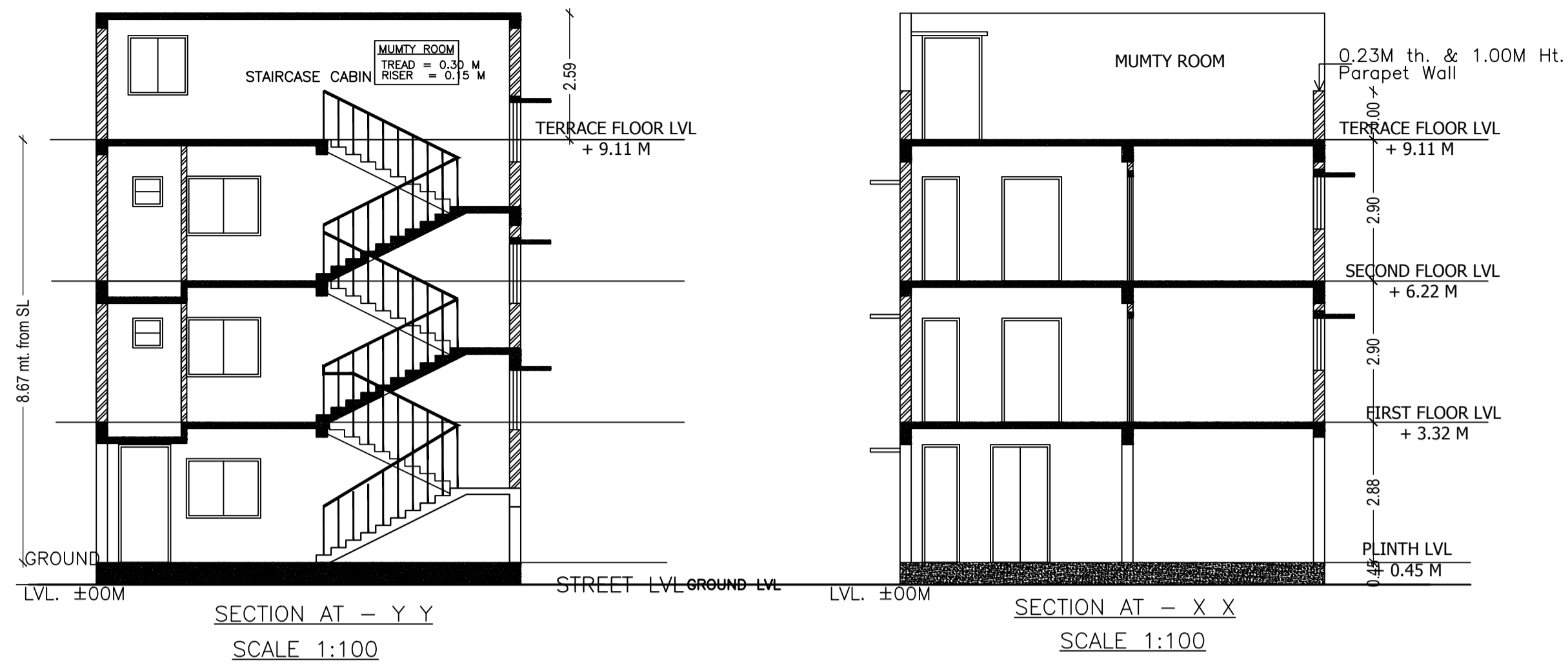

LTP NAME AND SIGNATURE	STRUCTURAL ENG'S NAME AND SIGNATURE	BUILDER NAME AND SIGNATURE
LAWRENCE FRANCIS JNAC/ARC/0003/2016		