

Proposal Basic Information	
Proposal File No.	JNAC/BP/0144/W3/2018
Owner Name	SMT. SARASWATI DEVI
Khata No	Nil
Plot No	H.NO. - 20-A-21
Village Name	Bisthupur
Use	Residential
SubUse	Bungalow/ Dwelling / Non Apartment

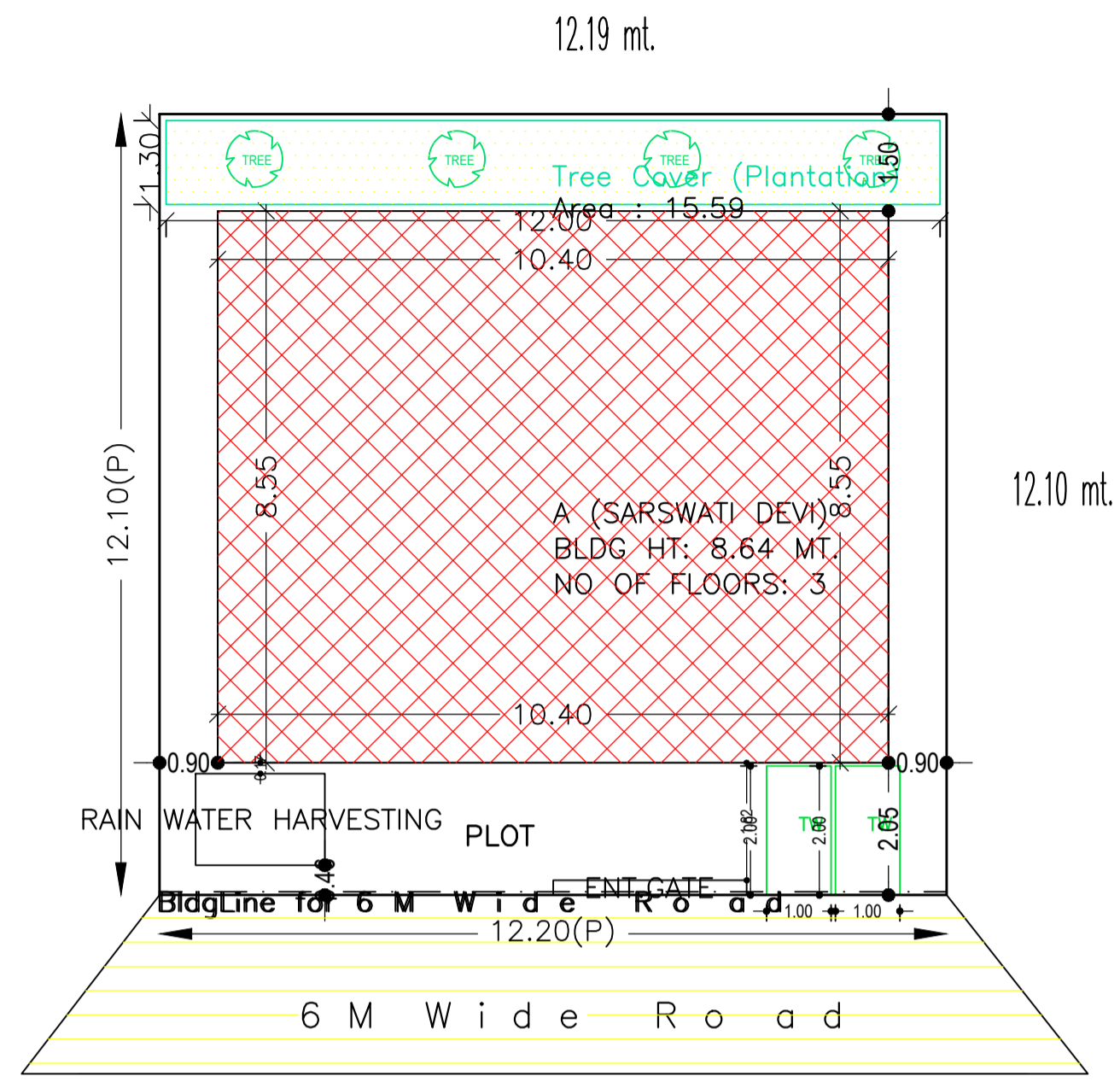

SITE PLAN  
SCALE : 1:100

AREA STATEMENT		VERSION NO. : 1.0.35
JAMSHEDPUR NAC		VERSION DATE: 13/03/2019
<b>PROJECT DETAIL:</b>		
Region: JHARKHAND URBAN LOCAL BODIES	Plot Use: Residential	
District: EAST SINGHBHUM	Plot SubUse: Bungalow/ Dwelling / Non Apartment	
Authority: JAMSHEDPUR NAC	Plot/Nearby/Religious/Structure: NA	
Inward No: JNAC/BP/0144/W3/2018	Plot/SubPlot No: H.NO. - 20-A-21	
Application Type: General Proposal	North: Road Width - 6.0	
Project Type: Building Permission	South: Survey No. - ALLEY	
Nature of Development: New	East: Plot No. - 20 & 19A	
Location of Development Area: Old Area	West: Plot No. - 21A	
<b>AREA DETAILS:</b>		
AREA OF PLOT (Minimum)	(A)	147.50
NET AREA OF PLOT(Gross Plot Area - Deduction from Gross Plot area)	(A-Deductions)	147.50
Deduction for Balance Plot Area(from Gross Plot Area)		
Common Plot		15.59
Total		15.59
BALANCE AREA OF PLOT(Net Plot Area - Recreational/Amenity space)	(A-Deductions)	131.91
PLOT AREA FOR COVERAGE(Net Plot Area)	(A-Deductions)	147.50
Plot Area for FAR (Net Plot Area + RoadWidening Area)	(A-Deductions)	147.50
<b>COVERAGE CHECK</b>		
Permissible Coverage area ( 70.00 % )		103.25
Proposed Coverage Area ( 60.22 % )		88.83
Total Prop. Coverage Area ( 60.22 % )		88.83
Balance coverage area ( 9.78 % )		14.42
<b>FAR CHECK</b>		
Perm. FAR Area ( 1.80 )		265.50
Total Perm. FAR area		265.50
Residential FAR		177.65
Proposed FAR Area		188.81
Total Proposed FAR Area		188.81
Consumed FAR (Factor)		1.28
Balance FAR Area		76.69
<b>BUILT UP AREA CHECK</b>		
Total Proposed BuiltUp Area		266.49
ARCHITECT (Regd)	L K Suman	
ENGINEER (Regd)		
SUPERVISOR (Regd)		
OWNER (Regd)	SMT. SARASWATI DEVI	
DEVELOPMENT AUTHORITY		LOCAL BODY

COLOR INDEX	
PLOT BOUNDARY	Black
ABUTTING ROAD	Green
PROPOSED CONSTRUCTION	Red
COMMON PLOT	Yellow
ROAD WIDENING AREA	Blue
EXISTING (To be retained)	Orange
EXISTING (To be demolished)	Light Blue

Buildingwise Floor FAR Details

Floor Name	Building Name A (SARSWATI DEVI)		Total	
	Proposed Built Up Area (Sq.mt.)	Proposed FAR Area (Sq.mt.)	Total Proposed Built Up Area (Sq.mt.)	Total FAR Area (Sq.mt.)
Ground Floor	88.83	11.16	88.83	11.16
First Floor	88.83	88.83	88.83	88.83
Second Floor	88.83	88.83	88.83	88.83
Terrace Floor	0.00	0.00	0.00	0.00
<b>Total :</b>	<b>266.49</b>	<b>188.82</b>	<b>266.49</b>	<b>188.82</b>

Building USE/SUBUSE Details

Building Name	Building Use	Building SubUse	Building Structure
A (SARSWATI DEVI)	Residential	Bungalow/ Dwelling / Non Apartment	Non-Highrise

Required Parking(Table 7a)

Building Name	Type	SubUse	Area (Sq.mt.)	Units		Car		Visitors Car		TwoWheeler	
				Reqd.	Prop.	Reqd./Unit	Reqd.	Prop.	Reqd./Unit	Reqd.	Prop.
A (SARSWATI DEVI)	Residential	Bungalow/ Dwelling / Non Apartment	> 0	1	2.00	1.00	2	-	-	-	-
			> 0	1	2.00	-	-	1	1	-	-
<b>Total :</b>			-	-	-	-	2	2	1	1	0

Parking Check (Table 7b)

Vehicle Type	Reqd.		Prop.	
	No.	Area	No.	Area
Car	-	-	2	25.00
Total Car	2	25.00	2	25.00
Visitor's Car Parking	-	-	1	12.50
Total Visitor Parking	1	12.50	1	12.50
TwoWheeler	-	-	2	4.00
Total TwoWheeler	-	-	2	4.00
Other Parking	-	-	-	40.17
<b>Total</b>		37.50		98.17

FAR & Tenement Details (Table 4c-1)

Building	No. of Same Bldg	Total Built Up Area (Sq.mt.)	Deductions (Area in Sq.mt.)		Proposed FAR Area (Sq.mt.)	Add Area In FAR (Sq.mt.)	Total FAR Area (Sq.mt.)	Total Consumed Additional FAR Area (Sq.mt.)	Tnmt (No.)
			Parking	Resi.					
A (SARSWATI DEVI)	1	266.49	77.67	177.66	11.16	188.82	188.82	02	
<b>Grand Total :</b>	<b>1</b>	<b>266.49</b>	<b>77.67</b>	<b>177.66</b>	<b>11.16</b>	<b>188.82</b>	<b>188.82</b>	<b>02</b>	

LTP NAME AND SIGNATURE	STRUCTURAL ENG'S NAME AND SIGNATURE	BUILDER NAME AND SIGNATURE	DIGITAL SIGNATURE
L K Suman JNAC/ENG/0006/2016			

Proposal Basic Information	
Proposal File No.	JNAC/BP/0144/W3/2018
Owner Name	SMT. SARASWATI DEVI
Khata No	Nil
Plot No	H.NO. - 20-A-21
Village Name	Bisthupur
Use	Residential
SubUse	Bungalow/ Dwelling / Non Apartment

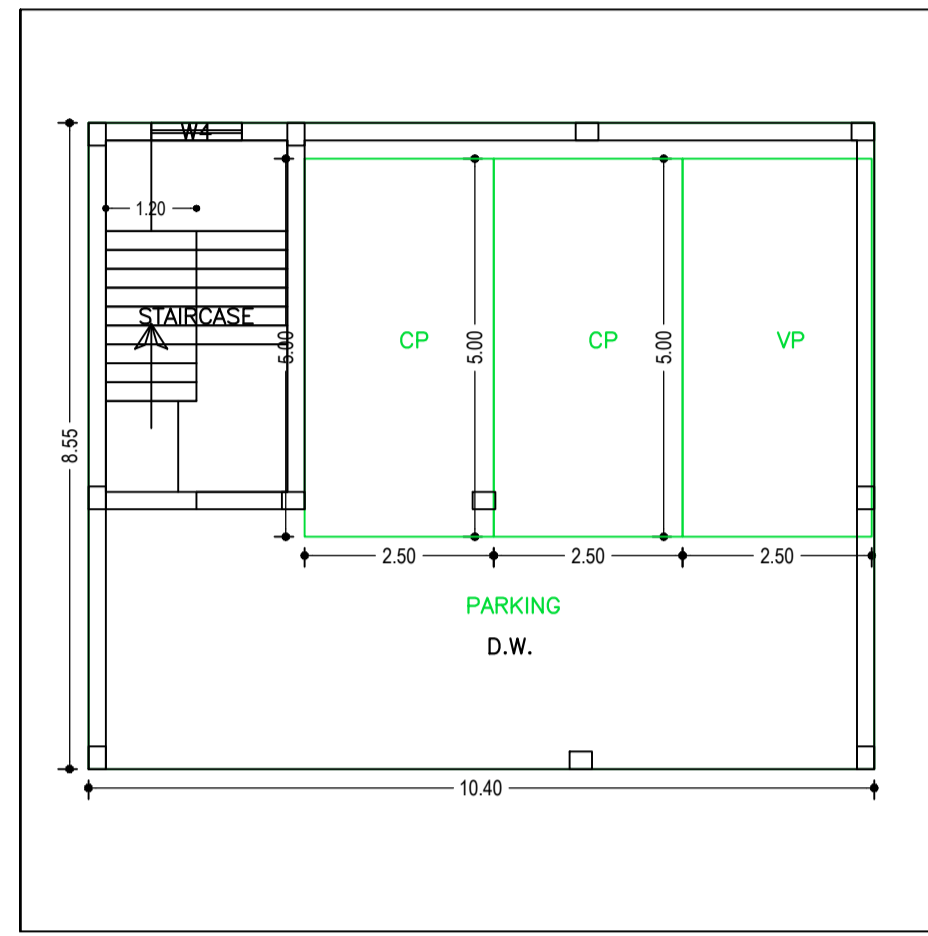

GROUND FLOOR PLAN  
(SCALE 1:100)

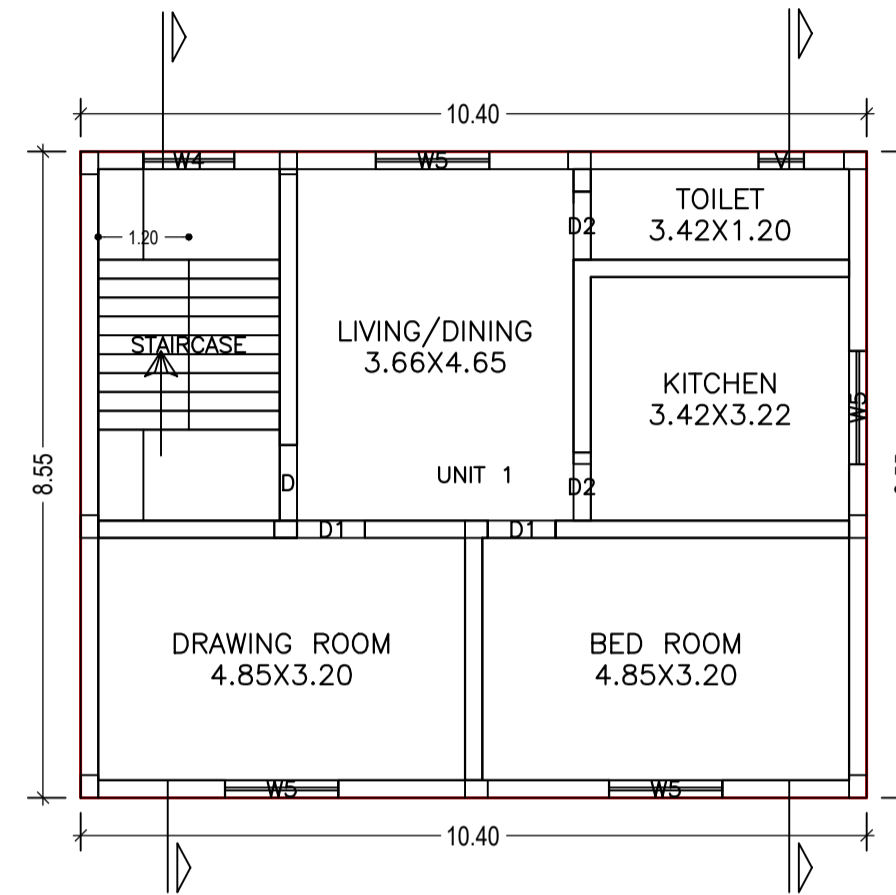

FIRST FLOOR PLAN  
(Proposed)  
(SCALE 1:100)

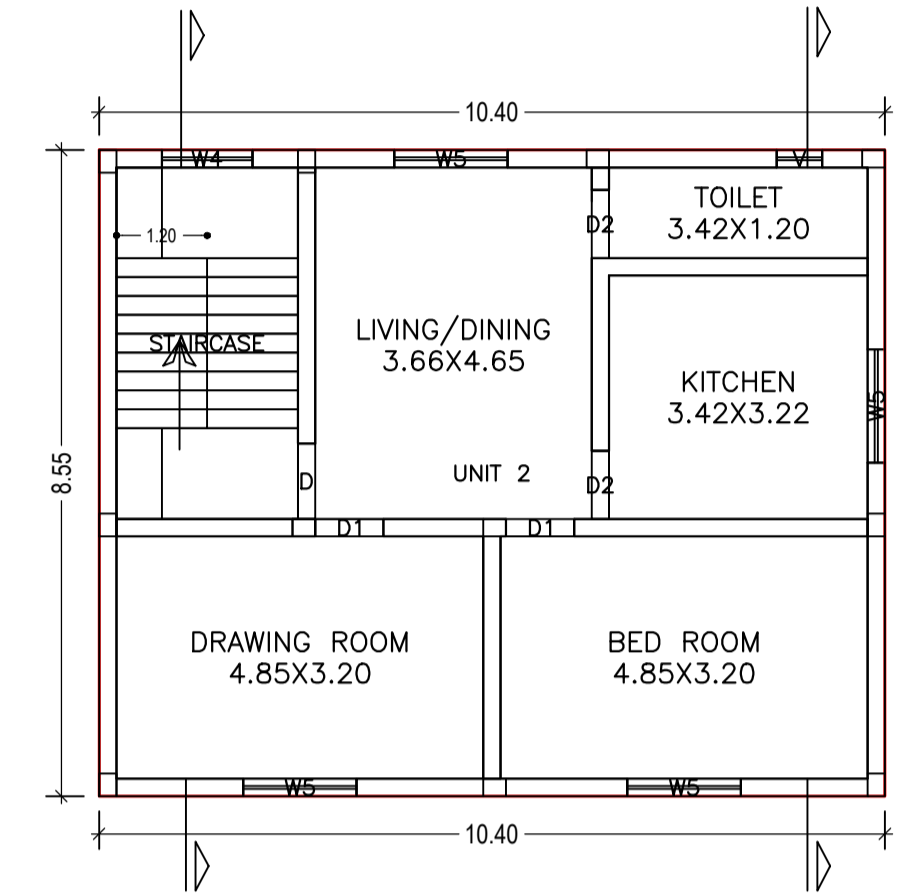

SECOND FLOOR PLAN  
(Proposed)  
(SCALE 1:100)

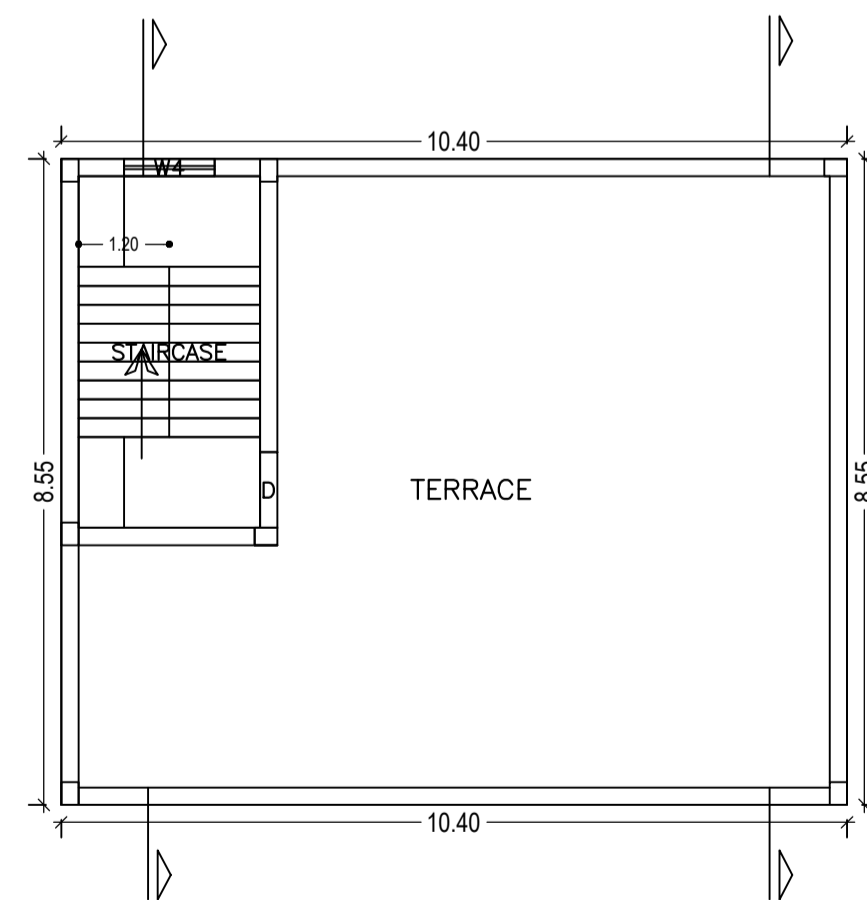

TERRACE FLOOR PLAN  
(SCALE 1:100)

LTP NAME AND SIGNATURE	STRUCTURAL ENG'S NAME AND SIGNATURE	BUILDER NAME AND SIGNATURE	DIGITAL SIGNATURE
L K Suman JNAC/ENG/0006/2016			

Proposal Basic Information	
Proposal File No.	JNAC/BP/0144/W3/2018
Owner Name	SMT. SARASWATI DEVI
Khata No	Nil
Plot No	H.NO. - 20-A-21
Village Name	Bisthupur
Use	Residential
SubUse	Bungalow/ Dwelling / Non Apartment

Building :A (SARSWATI DEVI)

Floor Name	Total Built Up Area (Sq.mt.)	Deductions (Area in Sq.mt.)		Proposed FAR Area (Sq.mt.)	Add Area in FAR (Sq.mt.)	Total FAR Area (Sq.mt.)	Total Consumed Additional FAR Area (Sq.mt.)	Tnmt (No.)
		Parking	Resi.					
Ground Floor	88.83	77.67	0.00	11.16	11.16	11.16	00	
First Floor	88.83	0.00	88.83	0.00	88.83	88.83	01	
Second Floor	88.83	0.00	88.83	0.00	88.83	88.83	01	
Terrace Floor	0.00	0.00	0.00	0.00	0.00	0.00	00	
Total :	266.49	77.67	177.66	11.16	188.82	188.82	02	
Total Number of Same Buildings :	1							
Total :	266.49	77.67	177.66	11.16	188.82	188.82	02	

SCHEDULE OF DOOR:

BUILDING NAME	NAME	LENGTH	HEIGHT	NOS
A (SARSWATI DEVI)	D1	0.90	2.10	04
A (SARSWATI DEVI)	D2	0.90	2.10	04
A (SARSWATI DEVI)	D	1.00	2.10	02

SCHEDULE OF WINDOW/VENTILATION:

BUILDING NAME	NAME	LENGTH	HEIGHT	NOS
A (SARSWATI DEVI)	V	0.60	0.60	02
A (SARSWATI DEVI)	W4	1.20	1.20	04
A (SARSWATI DEVI)	W5	1.50	1.20	08

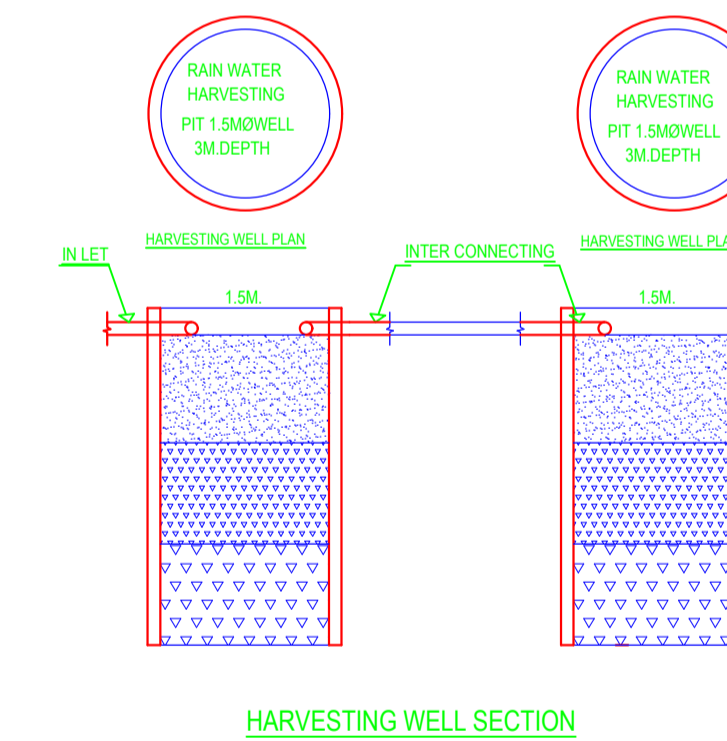
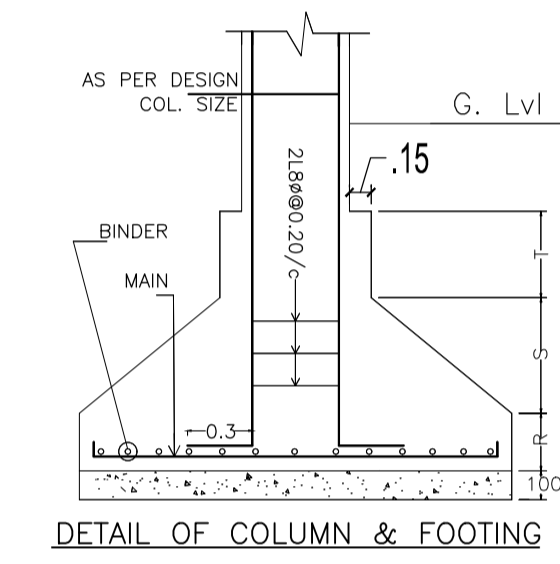
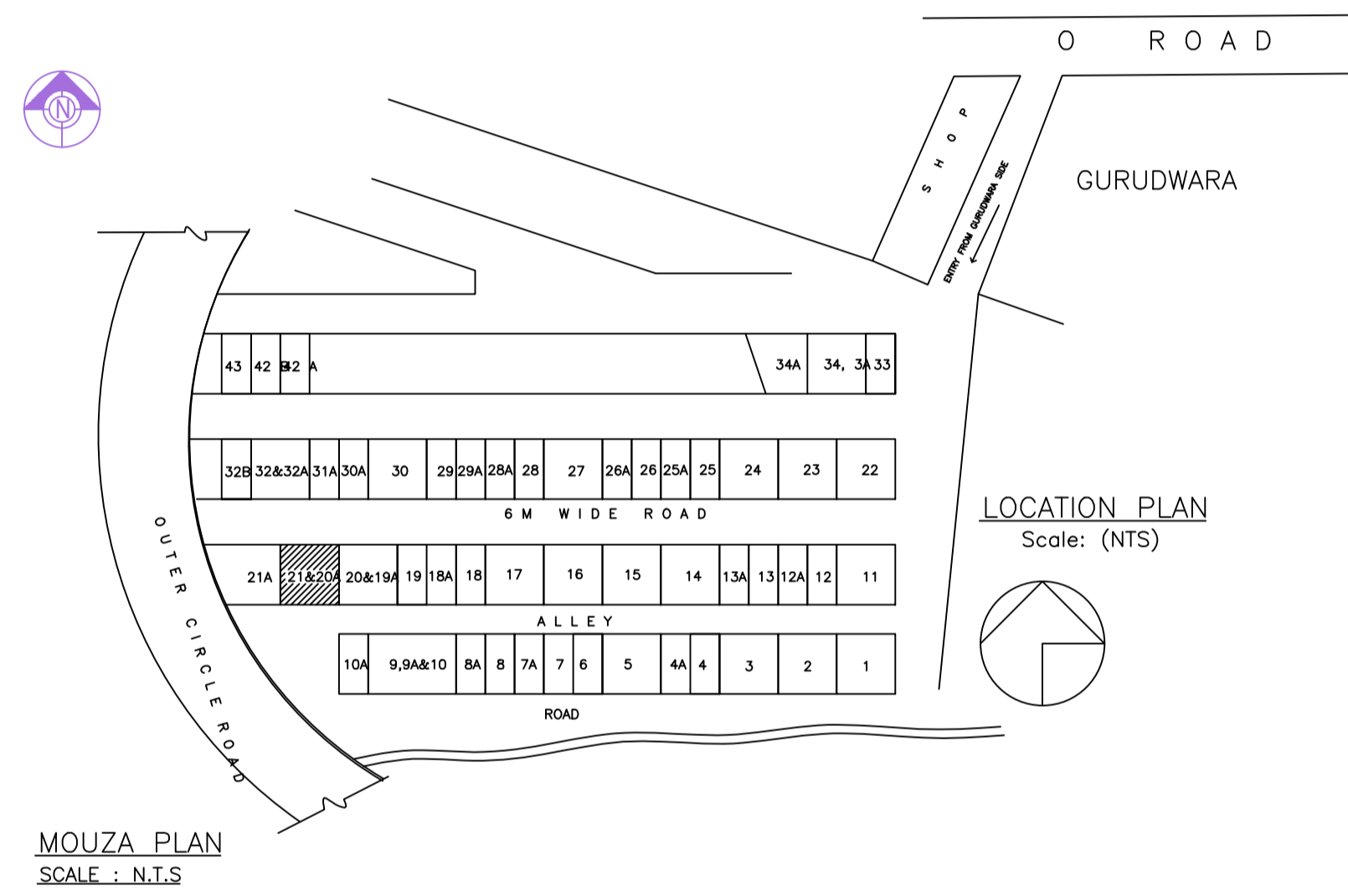

LTP NAME AND SIGNATURE	STRUCTURAL ENG'S NAME AND SIGNATURE	BUILDER NAME AND SIGNATURE	DIGITAL SIGNATURE
L K Suman JNAC/ENG/0006/2016			

Proposal Basic Information	
Proposal File No.	JNAC/BP/0144/W3/2018
Owner Name	SMT. SARASWATI DEVI
Khata No	Nil
Plot No	H.NO. - 20-A-21
Village Name	Bisthupur
Use	Residential
SubUse	Bungalow/ Dwelling / Non Apartment

UnitBUA Table for Building :A (SARSWATI DEVI)

FLOOR	Name	UnitBUA Type	UnitBUA Area	Carpet Area	No. of Rooms	No. of Tenement
FIRST FLOOR PLAN	UNIT 1	FLAT	80.32	75.44	5	1
SECOND FLOOR PLAN	UNIT 2	FLAT	80.32	75.44	5	1
Total	-	-	160.64	150.88	10	2

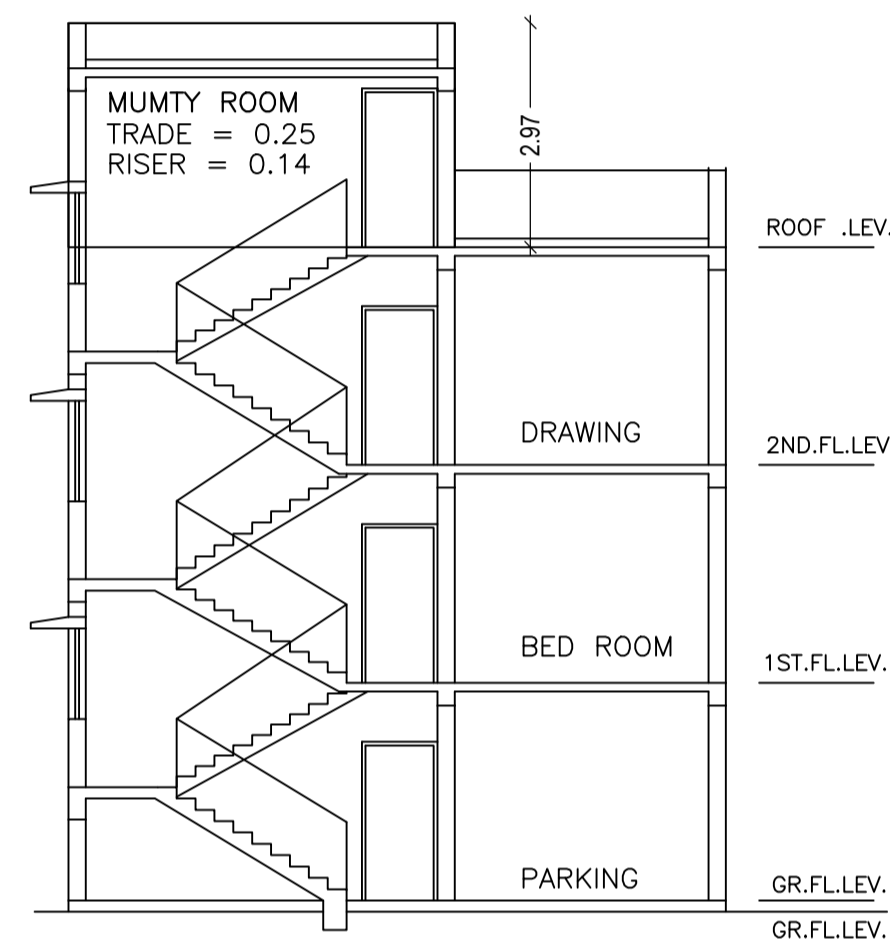

SCALE : 1:100

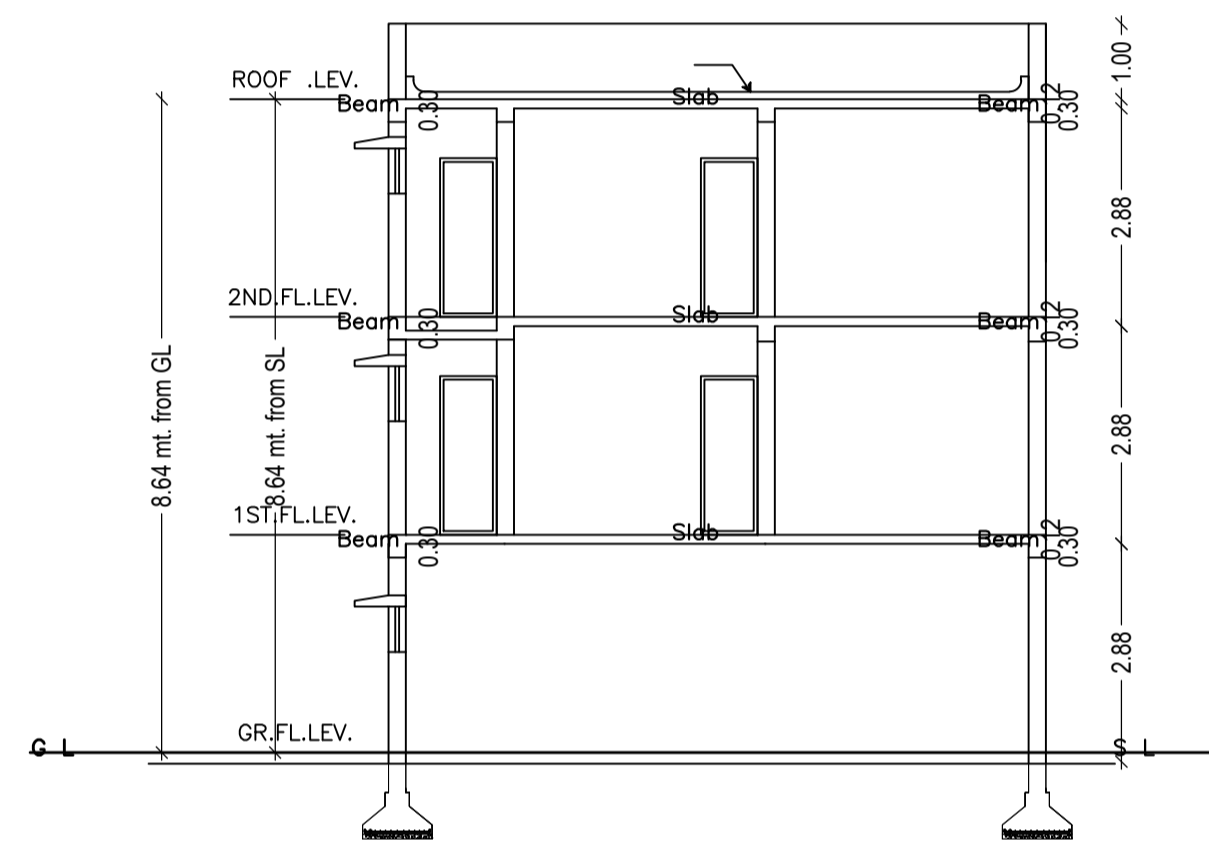

SECTION -Y-Y'  
SCALE : 1:100

LTP NAME AND SIGNATURE	STRUCTURAL ENG'S NAME AND SIGNATURE	BUILDER NAME AND SIGNATURE	DIGITAL SIGNATURE
L K Suman JNAC/ENG/0006/2016			

Proposal Basic Information	
Proposal File No.	JNAC/BP/0144/W3/2018
Owner Name	SMT. SARASWATI DEVI
Khata No	Nil
Plot No	H.NO. - 20-A-21
Village Name	Bisthupur
Use	Residential
SubUse	Bungalow/ Dwelling / Non Apartment

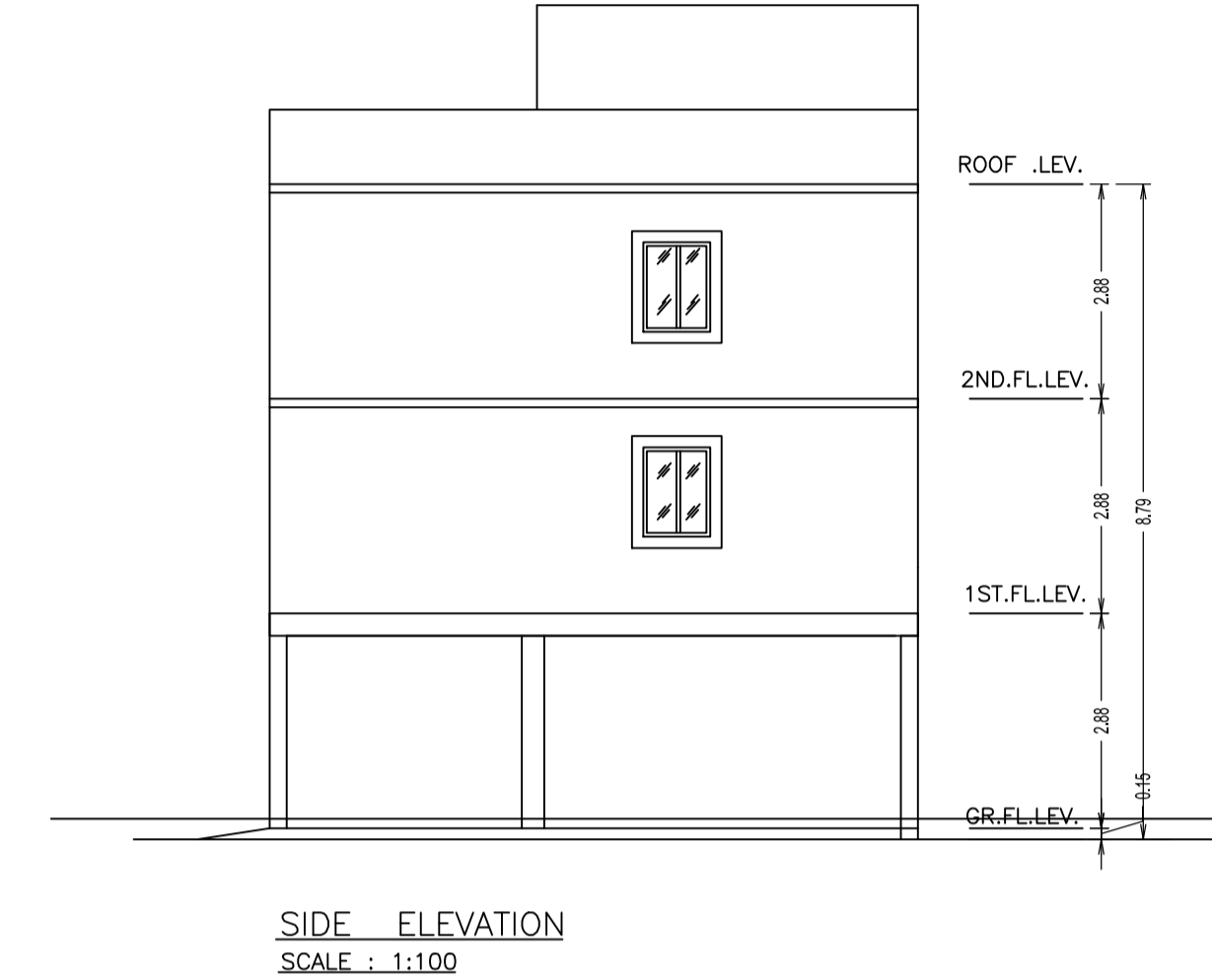
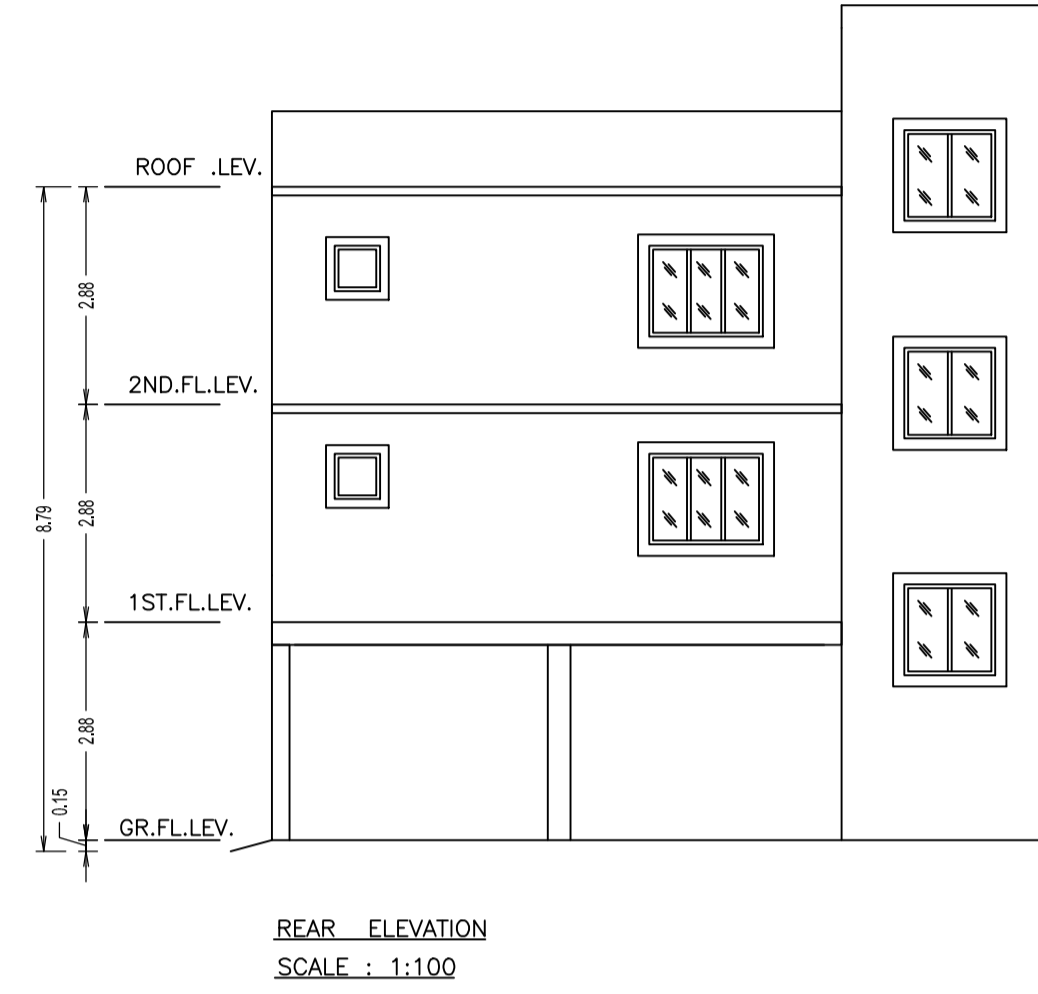
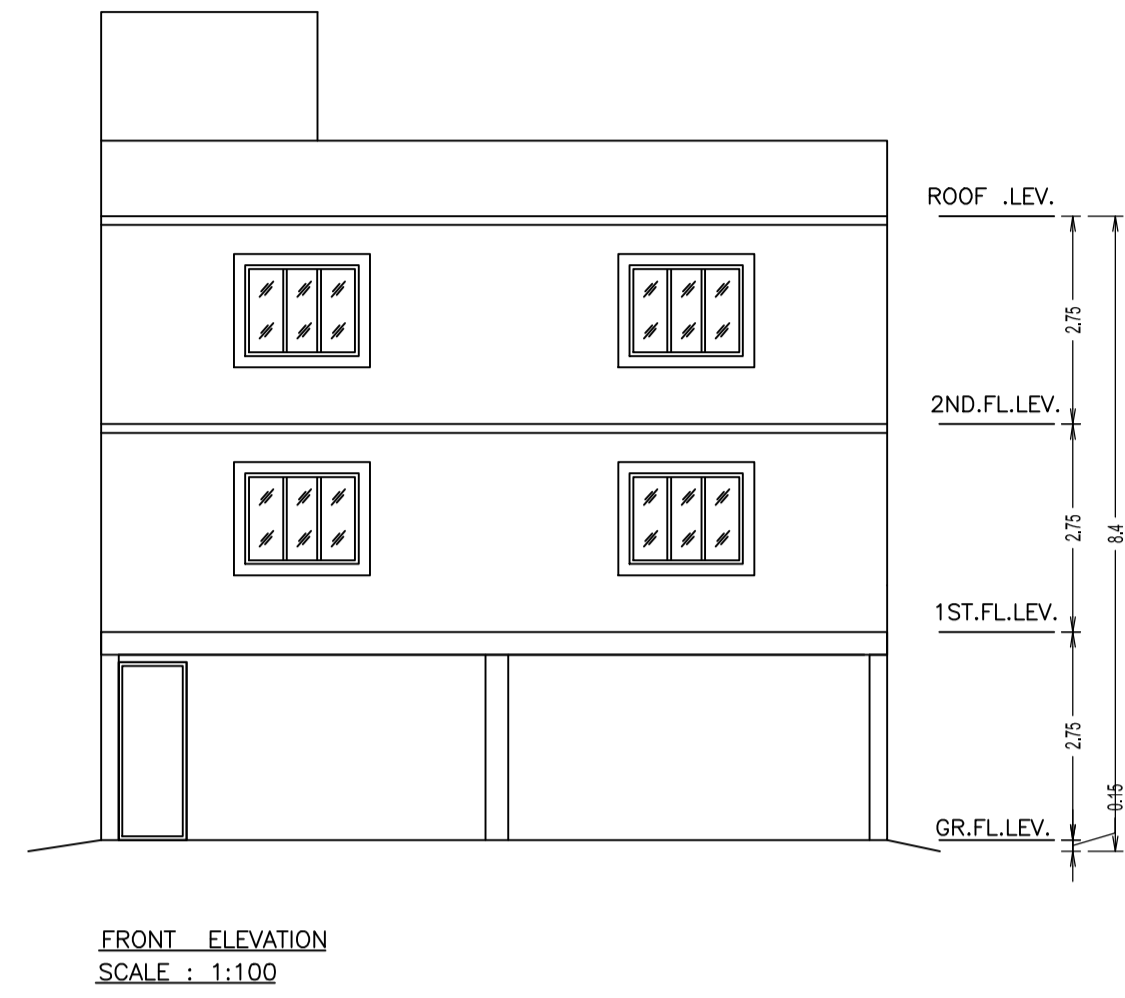

LTP NAME AND SIGNATURE	STRUCTURAL ENG'S NAME AND SIGNATURE	BUILDER NAME AND SIGNATURE	DIGITAL SIGNATURE
L K Suman JNAC/ENG/0006/2016			