

Proposal Basic Information	
Proposal File No.	JNAC/BP/0032/W7/2019
Owner Name	SMT. MANJU KAUNTIA
Khata No	Nil
Plot No	H.NO.-87
Village Name	SAKCHI
Use	Residential
SubUse	Individual Row House

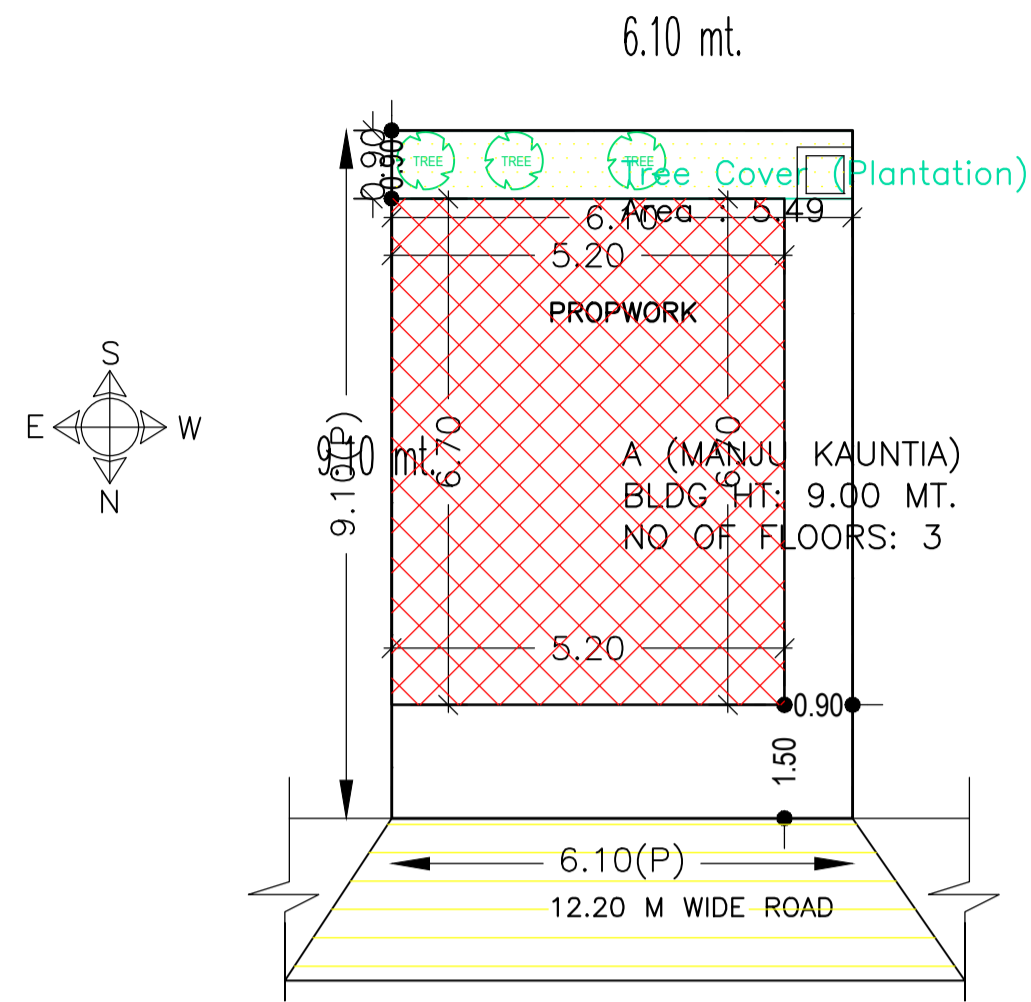

SITE PLAN  
SCALE : 1:100

AREA STATEMENT		VERSION NO.: 1.0.39
JAMSHEDPUR NAC		VERSION DATE: 29/04/2019
<b>PROJECT DETAIL:</b>		
Region: JHARKHAND URBAN LOCAL BODIES	Plot Use: Residential	
District: EAST SINGHBHUM	Plot SubUse: Individual Row House	
Authority: JAMSHEDPUR NAC	PlotNearby/ReligiousStructure: NA	
Inward_No: JNAC/BP/0032/W7/2019	Plot/SubPlot No: H.NO.-87	
Application Type: General Proposal	North: Road Width - 14	
Project Type: Building Permission	South: Survey No. - ALLEY	
Nature of Development: New	East: Plot No. - 86	
Location of Development Area: Old Area	West: Plot No. - 88	
<b>AREA DETAILS:</b>		SQ.MT.
AREA OF PLOT (Minimum)	(A)	55.46
NET AREA OF PLOT(Gross Plot Area - Deduction from Gross Plot area)	(A-Deductions)	55.46
Deduction for Balance Plot Area(from Gross Plot Area)		
Common Plot		5.49
Total		5.49
BALANCE AREA OF PLOT(Net Plot Area - Recreational/Amenity space)	(A-Deductions)	49.97
PLOT AREA FOR COVERAGE(Net Plot Area)	(A-Deductions)	55.46
Plot Area for FAR (Net Plot Area + Road/Widening Area)	(A-Deductions)	55.46
<b>COVERAGE CHECK</b>		
Permissible Coverage area ( 70.00 % )		38.82
Proposed Coverage Area ( 62.75 % )		34.80
Total Prop. Coverage Area ( 62.75 % )		34.80
Balance coverage area ( 7.25 % )		4.02
<b>FAR CHECK</b>		
Perm. FAR Area ( 2.50 )		138.65
Total Perm. FAR area		138.65
Residential FAR		104.40
Proposed FAR Area		104.40
Total Proposed FAR Area		104.40
Consumed FAR (Factor)		1.88
Balance FAR Area		34.25
<b>BUILT UP AREA CHECK</b>		
Total Proposed BuiltUp Area		104.40
ARCHITECT (Regd)	L K Suman	
ENGINEER (Regd)		
SUPERVISOR (Regd)		
OWNER (Regd)	SMT. MANJU KAUNTIA	
DEVELOPMENT AUTHORITY	LOCAL BODY	

COLOR INDEX	
PLOT BOUNDARY	Black
ABUTTING ROAD	Green
PROPOSED CONSTRUCTION	Red
COMMON PLOT	Yellow
ROAD WIDENING AREA	Blue
EXISTING (To be retained)	Orange
EXISTING (To be demolished)	Light Blue

Buildingwise Floor FAR Details

Floor Name	Building Name		Total	
	A (MANJU KAUNTIA)		Total Proposed Built Up Area (Sq.mt.)	Total FAR Area (Sq.mt.)
Ground Floor	Proposed Built Up Area (Sq.mt.)	34.80	34.80	34.80
First Floor		34.80	34.80	34.80
Second Floor		34.80	34.80	34.80
Terrace Floor		0.00	0.00	0.00
Total :		104.40	104.40	104.40

Building USE/SUBUSE Details

Building Name	Building SubUse	Building Structure
A (MANJU KAUNTIA)	Residential	Bungalow/ Dwelling / Non Apartment

FAR & Tenement Details (Table 4c-1)

	No. of Same Bldg	Total Built Up Area (Sq.mt.)	Proposed FAR Area (Sq.mt.)	Total FAR Area (Sq.mt.)	Total Consumed Additional FAR Area (Sq.mt.)	Tnmt (No.)
A (MANJU KAUNTIA)	1	104.40	104.40	104.40	104.40	01
Grand Total :	1	104.40	104.40	104.40	104.40	01

LTP NAME AND SIGNATURE	STRUCTURAL ENG'S NAME AND SIGNATURE	BUILDER NAME AND SIGNATURE	DIGITAL SIGNATURE
L K Suman JNAC/ENG/0006/2016			

Proposal Basic Information	
Proposal File No.	JNAC/BP/0032/W7/2019
Owner Name	SMT. MANJU KAUNTIA
Khata No	Nil
Plot No	H.NO.-87
Village Name	SAKCHI
Use	Residential
SubUse	Individual Row House

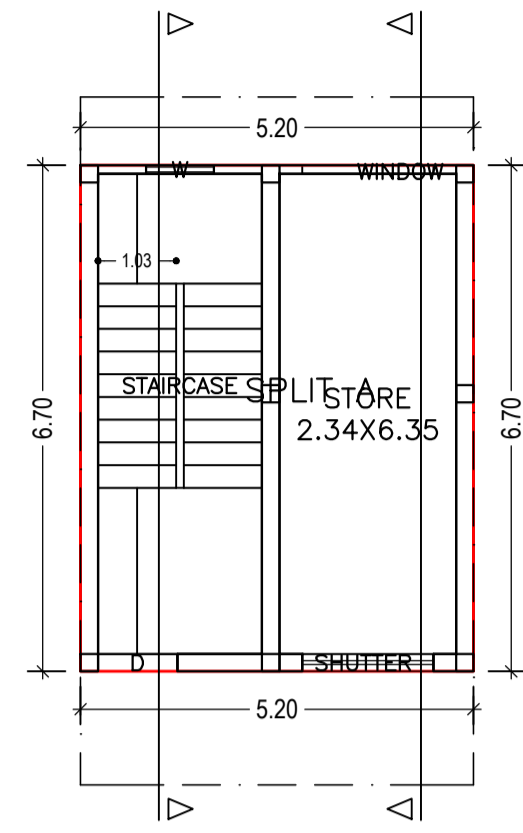

GROUND FLOOR PLAN  
(Proposed)  
(SCALE 1:100)

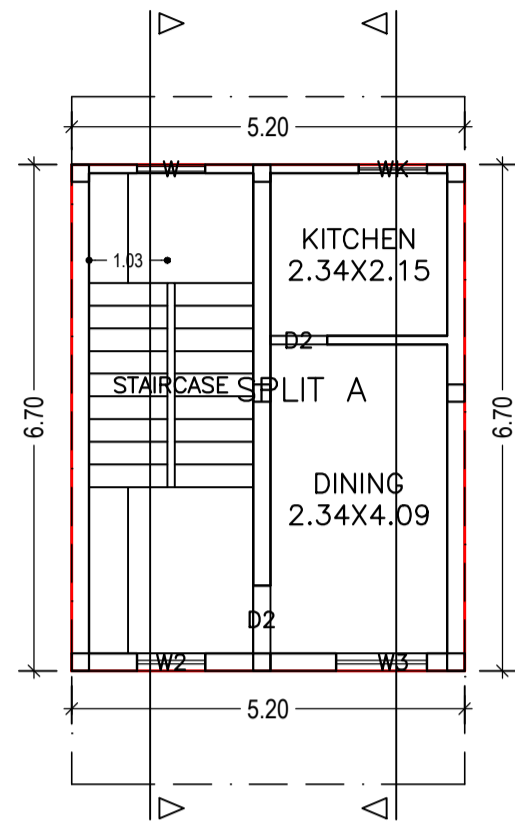

FIRST FLOOR PLAN  
(Proposed)  
(SCALE 1:100)

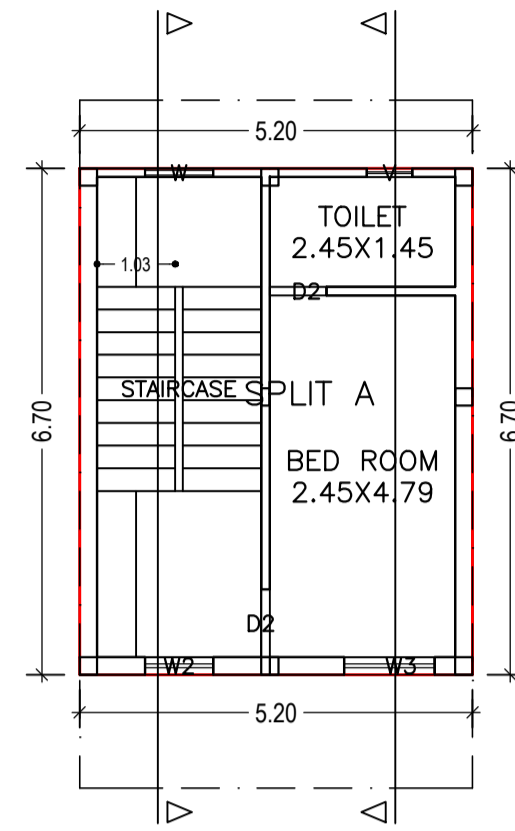

SECOND FLOOR PLAN  
(Proposed)  
(SCALE 1:100)

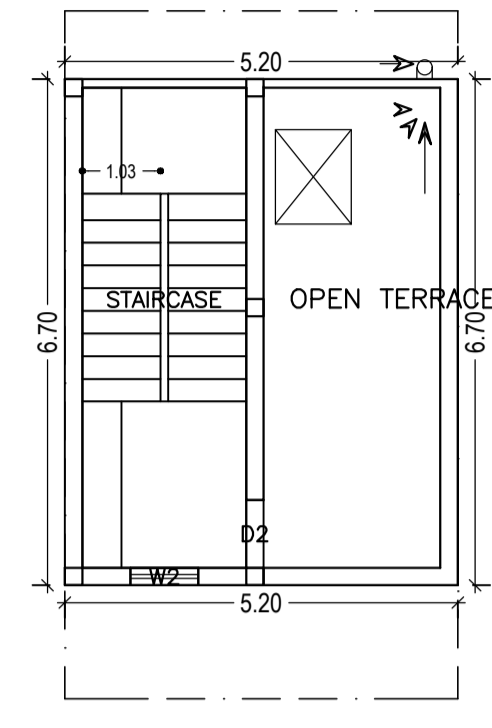

TERRACE FLOOR PLAN  
(SCALE 1:100)

Building :A (MANJU KAUNTIA)

Floor Name	Total Built Up Area (Sq.mt.)	Proposed FAR Area (Sq.mt.) Resi.	Total FAR Area (Sq.mt.)	Total Consumed Additional FAR Area (Sq.mt.)	Tnmt (No.)
Ground Floor	34.80	34.80	34.80	34.80	01
First Floor	34.80	34.80	34.80	34.80	00
Second Floor	34.80	34.80	34.80	34.80	00
Terrace Floor	0.00	0.00	0.00	0.00	00
Total :	104.40	104.40	104.40	104.40	01
Total Number of Same Buildings :	1				
Total :	104.40	104.40	104.40	104.40	01

SCHEDULE OF DOOR:

BUILDING NAME	NAME	LENGTH	HEIGHT	NOS
A (MANJU KAUNTIA)	D2	0.75	2.10	02
A (MANJU KAUNTIA)	D2	0.90	2.10	02
A (MANJU KAUNTIA)	SHUTTER	1.74	2.10	01

SCHEDULE OF WINDOW/VENTILATION:

BUILDING NAME	NAME	LENGTH	HEIGHT	NOS
A (MANJU KAUNTIA)	V	0.60	0.75	01
A (MANJU KAUNTIA)	WK	0.90	0.90	01
A (MANJU KAUNTIA)	W2	0.90	1.20	03
A (MANJU KAUNTIA)	W	0.90	1.20	03
A (MANJU KAUNTIA)	W3	1.20	1.20	02
A (MANJU KAUNTIA)	WINDOW	1.74	2.10	01

LTP NAME AND SIGNATURE	STRUCTURAL ENG'S NAME AND SIGNATURE	BUILDER NAME AND SIGNATURE	DIGITAL SIGNATURE
L K Suman JNAC/ENG/0006/2016			

Proposal Basic Information	
Proposal File No.	JNAC/BP/0032/W7/2019
Owner Name	SMT. MANJU KAUNTIA
Khata No	Nil
Plot No	H.NO.-87
Village Name	SAKCHI
Use	Residential
SubUse	Individual Row House

UnitBUA Table for Building :A (MANJU KAUNTIA)

FLOOR	Name	UnitBUA Type	UnitBUA Area	Carpet Area	No. of Rooms	No. of Tenement
GROUND FLOOR PLAN	SPLIT A	FLAT	104.40	88.31	1	1
FIRST FLOOR PLAN	SPLIT A	FLAT	0.00	0.00	2	0
SECOND FLOOR PLAN	SPLIT A	FLAT	0.00	0.00	2	0
Total:	-	-	104.40	88.31	5	1

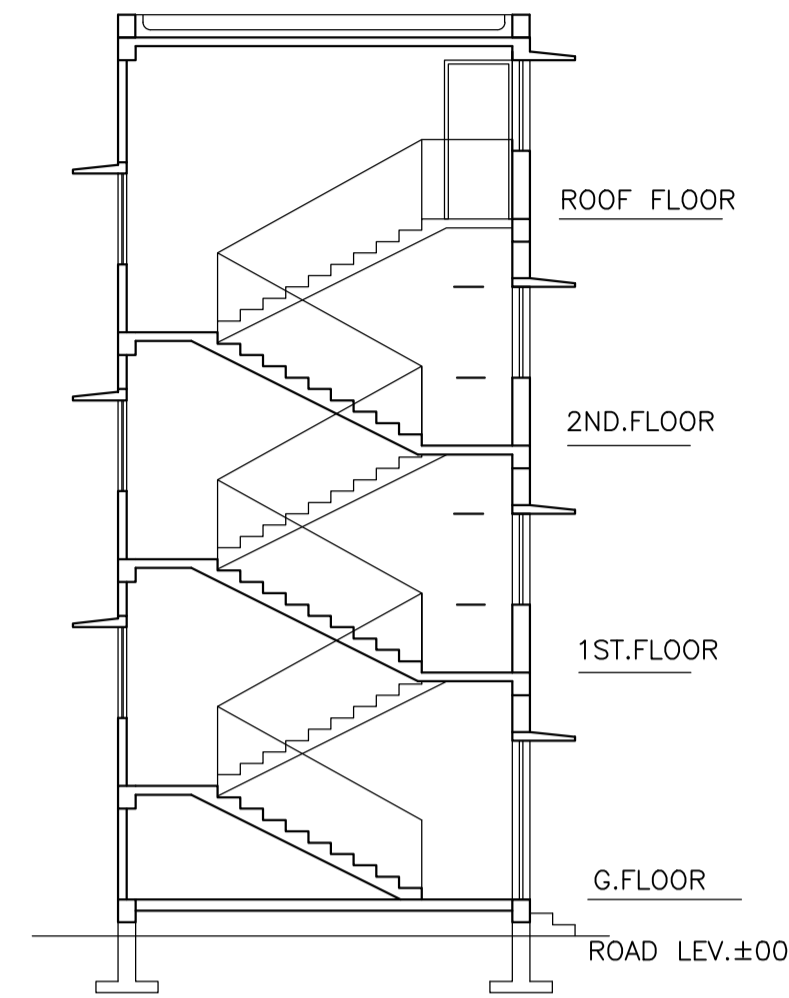

SECTION - A-A'  
SCALE : 1:100

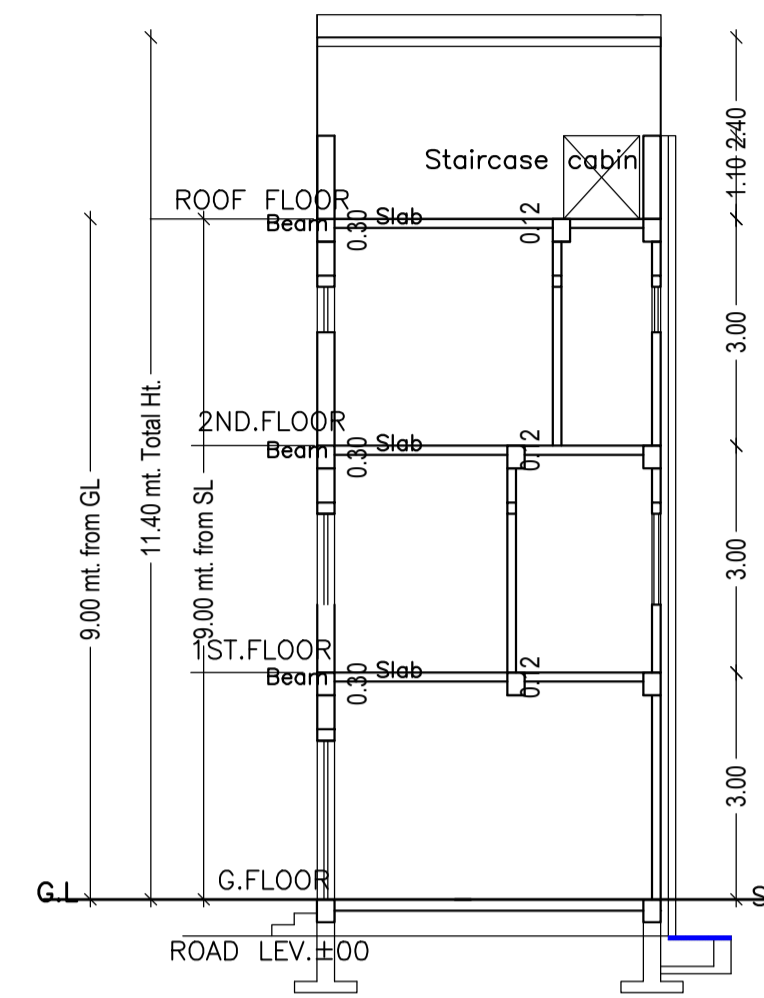

SECTION - B-B'  
SCALE : 1:100

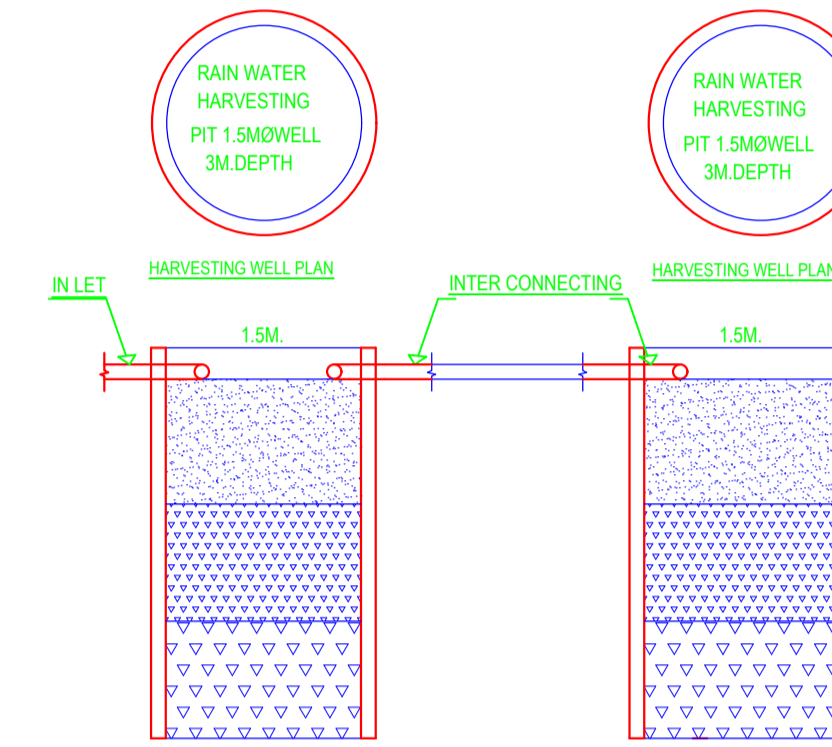

HARVESTING WELL SECTION

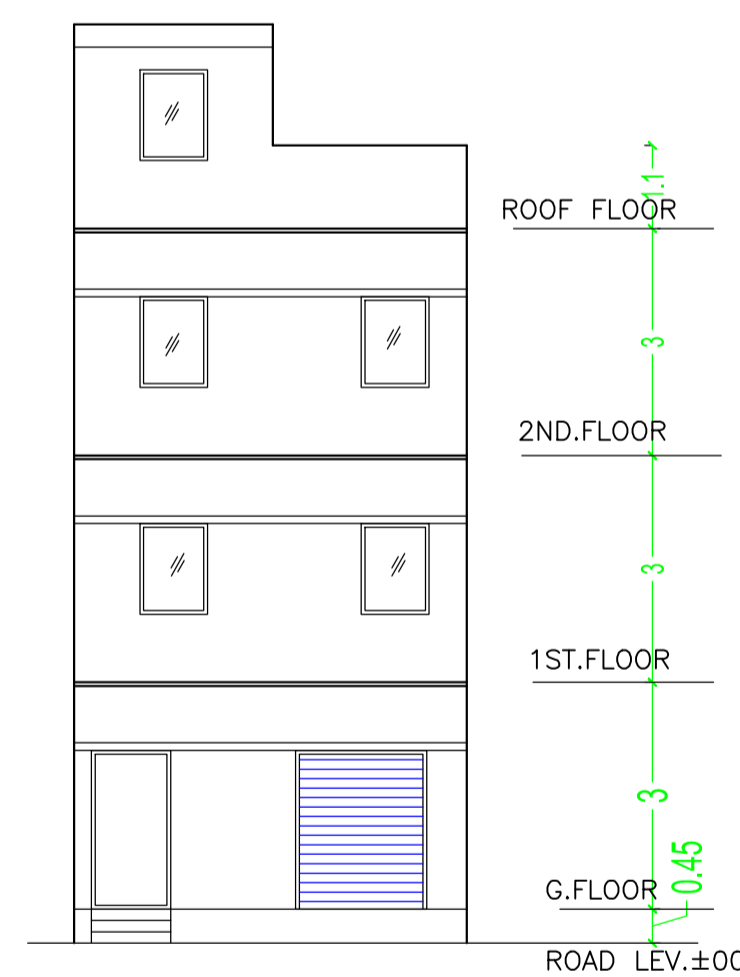

FRONT ELEVATION  
SCALE : 1:100

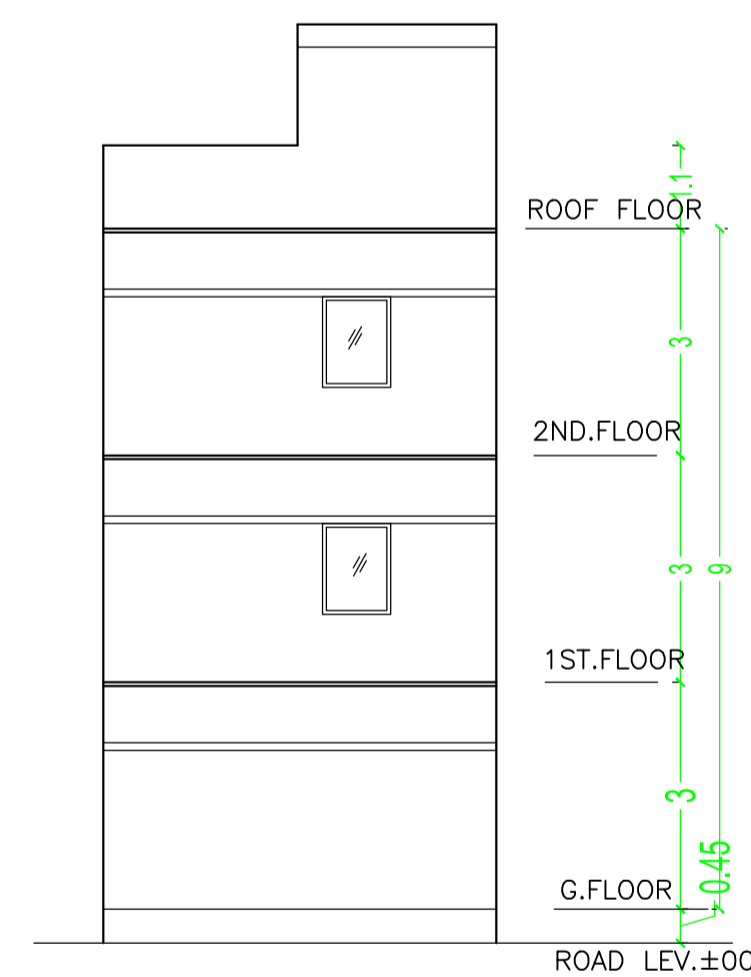

REAR ELEVATION  
SCALE : 1:100

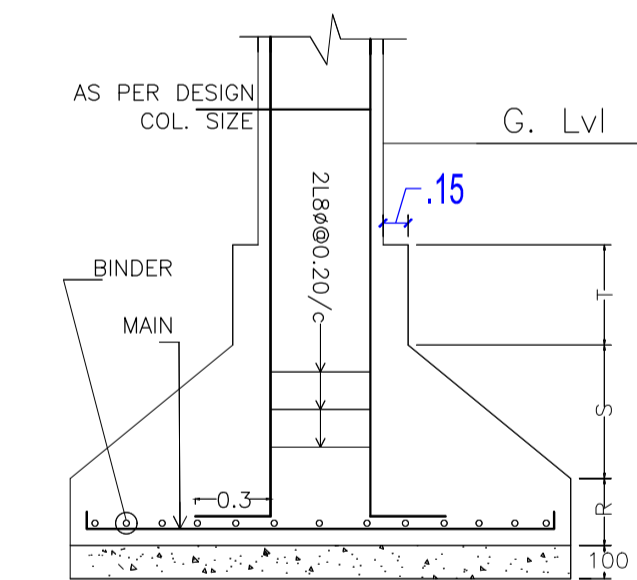

DETAIL OF COLUMN & FOOTING

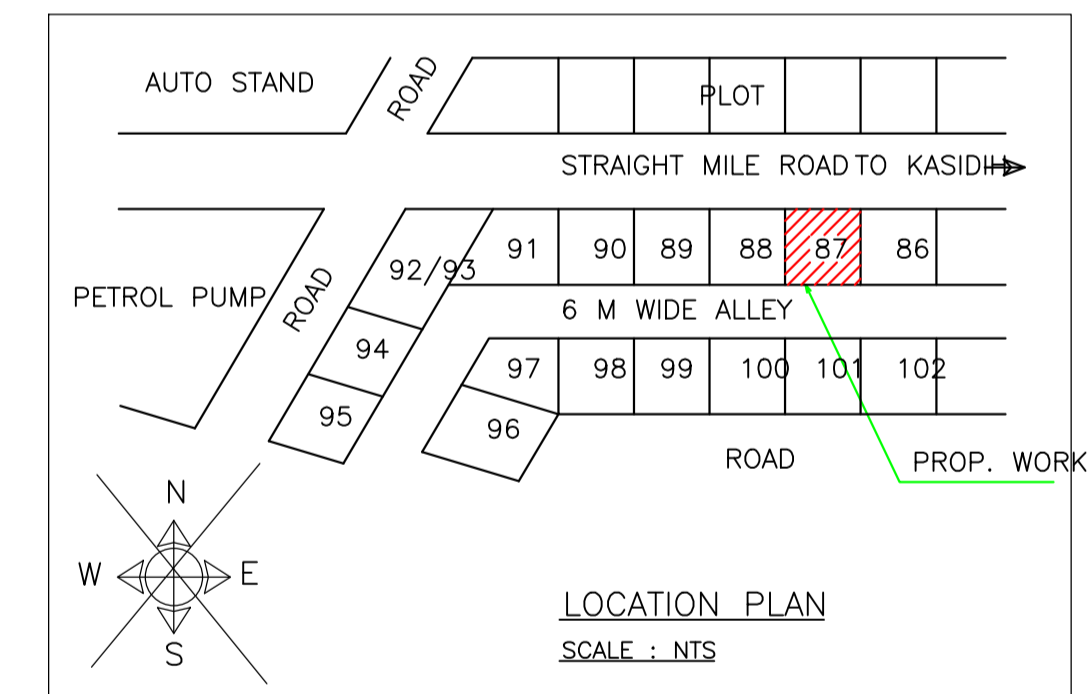

LOCATION PLAN  
SCALE : NTS

LTP NAME AND SIGNATURE	STRUCTURAL ENG'S NAME AND SIGNATURE	BUILDER NAME AND SIGNATURE	DIGITAL SIGNATURE
L K Suman JNAC/ENG/0006/2016			