

FAR & Tenement Details (Table 4c-1)

Building	No. of Same Bldg	Total Built Up Area (Sq.mt.)	Deductions (Area in Sq.mt.)		Proposed FAR Area (Sq.mt.)	Add Area In FAR (Sq.mt.)	Total FAR Area (Sq.mt.)	Total Consumed Additional FAR Area (Sq.mt.)	Trmnt (No.)
			Parking	Resi.					
A (RESIDENTIAL)	1	135.52	29.80	94.34	11.38	105.72	105.72	01	
<b>Grand Total :</b>	<b>1</b>	<b>135.52</b>	<b>29.80</b>	<b>94.34</b>	<b>11.38</b>	<b>105.72</b>	<b>105.72</b>	<b>01</b>	

Proposal Basic Information

Proposal File No.	JNAC/BP/0087/W11/2019
Owner Name	sri Bupendra kumar and others
Khata No	52
Plot No	1932
Village Name	SAKCHI
Use	Residential
SubUse	Bungalow/ Dwelling / Non Apartment

AREA STATEMENT JAMSHEDPUR NAC	VERSION NO. : 1.0.42 VERSION DATE: 29/04/2019
PROJECT DETAIL:	
Region: JHARKHAND URBAN LOCAL BODIES	Plot Use: Residential
District: EAST SINGHBHUM	Plot SubUse: Bungalow/ Dwelling / Non Apartment
Authority: JAMSHEDPUR NAC	PlotNearby/ReligiousStructure: NA
Inward_No: JNAC/BP/0087/W11/2019	PlotSubPlot No: 1932
Application Type: General Proposal	North: Plot No. - other plot
Project Type: Building Permission	South: Plot No. - other plot
Nature of Development: New	East: Road Width - 8.0
Location of Development Area: New Area	West: Road Width - 9.7
AREA DETAILS:	
AREA OF PLOT (Minimum)	(A) 74.32
NET AREA OF PLOT(Gross Plot Area - Deduction from Gross Plot area)	(A-Deductions) 74.32
Deduction for Balance Plot Area(from Gross Plot Area)	
Common Plot	7.68
Total	7.68
BALANCE AREA OF PLOT(Net Plot Area - Recreational/Amenity space)	(A-Deductions) 66.64
PLOT AREA FOR COVERAGE(Net Plot Area)	(A-Deductions) 74.32
Plot Area for FAR (Net Plot Area + RoadWidening Area)	(A-Deductions) 74.32
COVERAGE CHECK	
Permissible Coverage area ( 70.00 % )	52.02
Proposed Coverage Area ( 60.76 % )	45.16
Total Prop. Coverage Area ( 60.76 % )	45.16
Balance coverage area ( 9.23 % )	6.86
FAR CHECK	
Perm. FAR Area ( 2.00 )	148.64
Total Perm. FAR area	148.64
Residential FAR	94.33
Proposed FAR Area	105.71
Total Proposed FAR Area	105.71
Consumed FAR (Factor)	1.42
Balance FAR Area	42.93
BUILT UP AREA CHECK	
Total Proposed BuiltUp Area	135.52
ARCHITECT (Regd)	S M shahreyar
ENGINEER (Regd)	
SUPERVISOR (Regd)	
OWNER (Regd)	sri Bupendra kumar and others
DEVELOPMENT AUTHORITY LOCAL BODY	

COLOR INDEX	
PLOT BOUNDARY	Black
ABUTTING ROAD	Green
PROPOSED CONSTRUCTION	Red
COMMON PLOT	Yellow
ROAD WIDENING AREA	Orange
EXISTING (To be retained)	Blue
EXISTING (To be demolished)	Light Blue

Buildingwise Floor FAR Details

Floor Name	Building Name A (RESIDENTIAL)		Total	
	Proposed Built Up Area (Sq.mt.)	Proposed FAR Area (Sq.mt.)	Total Proposed Built Up Area (Sq.mt.)	Total FAR Area (Sq.mt.)
Ground Floor	45.16	15.36	45.16	15.36
First Floor	45.18	45.18	45.18	45.18
Second Floor	45.18	45.18	45.18	45.18
Terrace Floor	0.00	0.00	0.00	0.00
<b>Total :</b>	<b>135.52</b>	<b>105.72</b>	<b>135.52</b>	<b>105.72</b>

Building USE/SUBUSE Details

Building Name	Building Use	Building SubUse	Building Structure
A (RESIDENTIAL)	Residential	Bungalow/ Dwelling / Non Apartment	Non-Highrise

LTP NAME AND SIGNATURE	STRUCTURAL ENG'S NAME AND SIGNATURE	BUILDER NAME AND SIGNATURE	DIGITAL SIGNATURE
S M shahreyar JNAC/ARC/0004/2018			

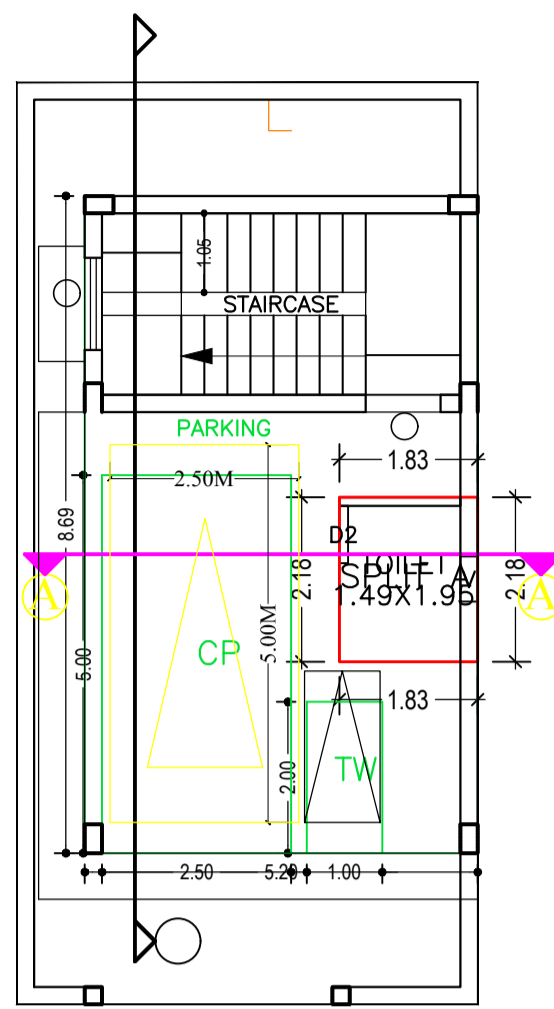

GROUND FLOOR PLAN (Proposed) (SCALE 1:100)

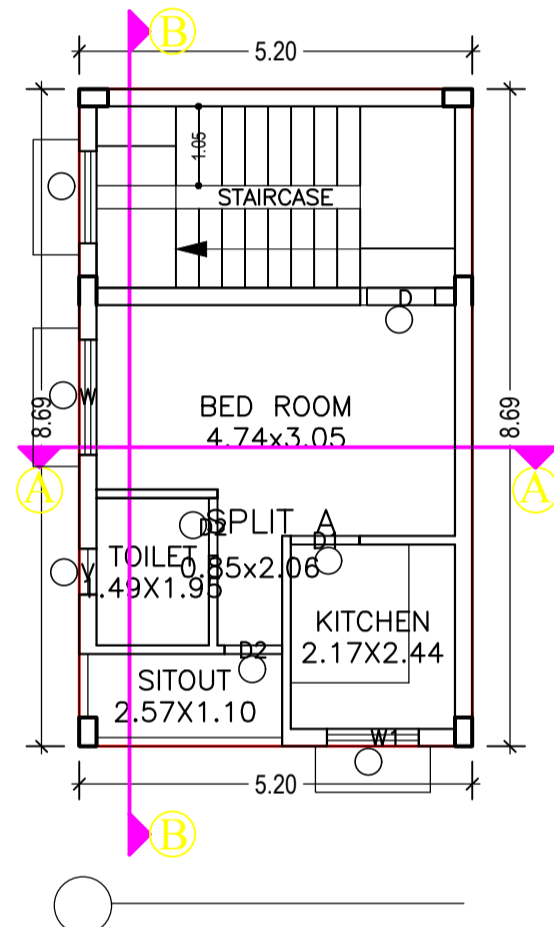

FIRST FLOOR PLAN (Proposed) (SCALE 1:100)

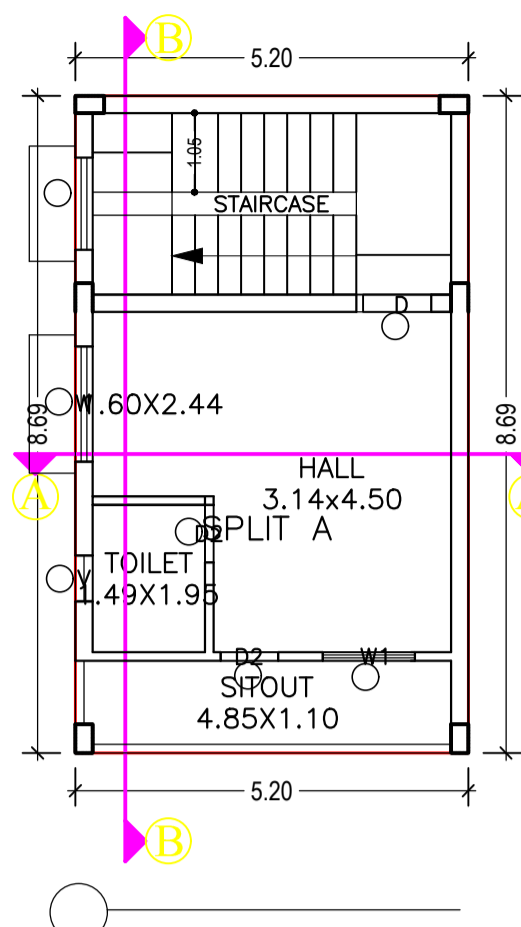

SECOND FLOOR PLAN (Proposed) (SCALE 1:100)

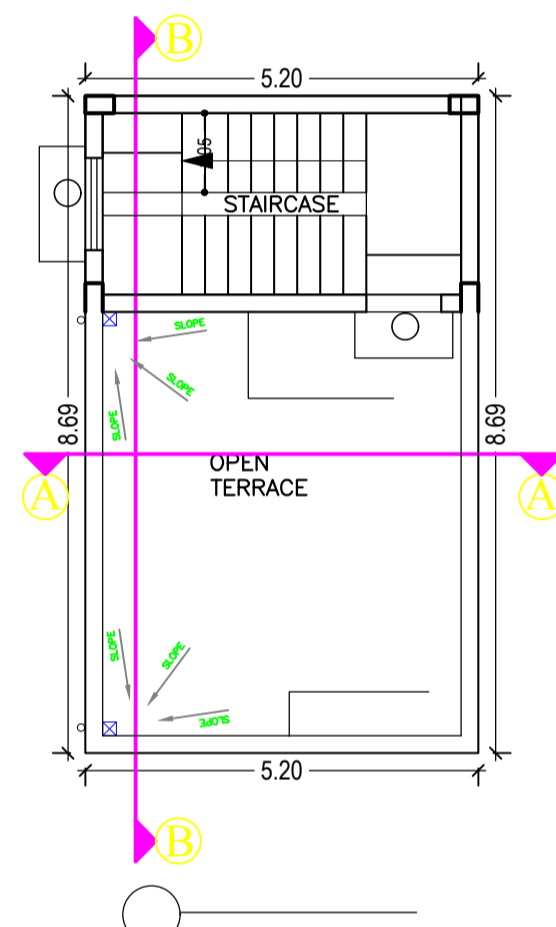

TERRACE FLOOR PLAN (Proposed) (SCALE 1:100)

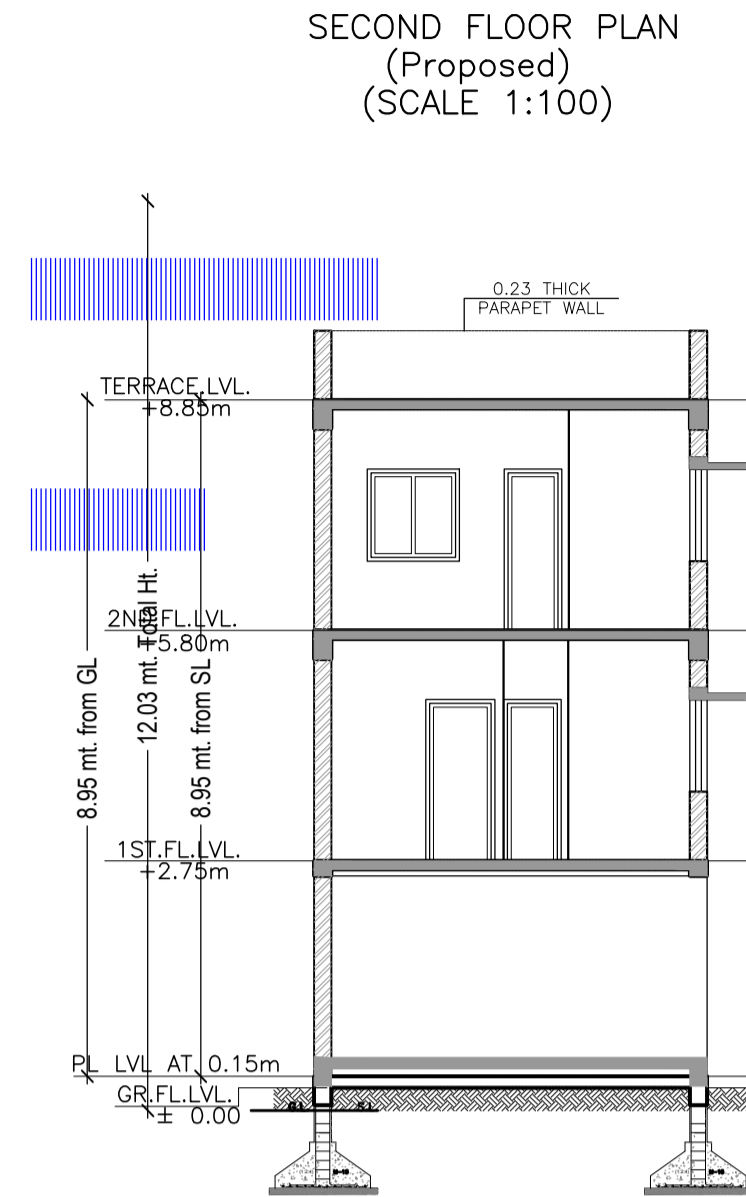

SECTION AT 'A-A' (SCALE 1:100)

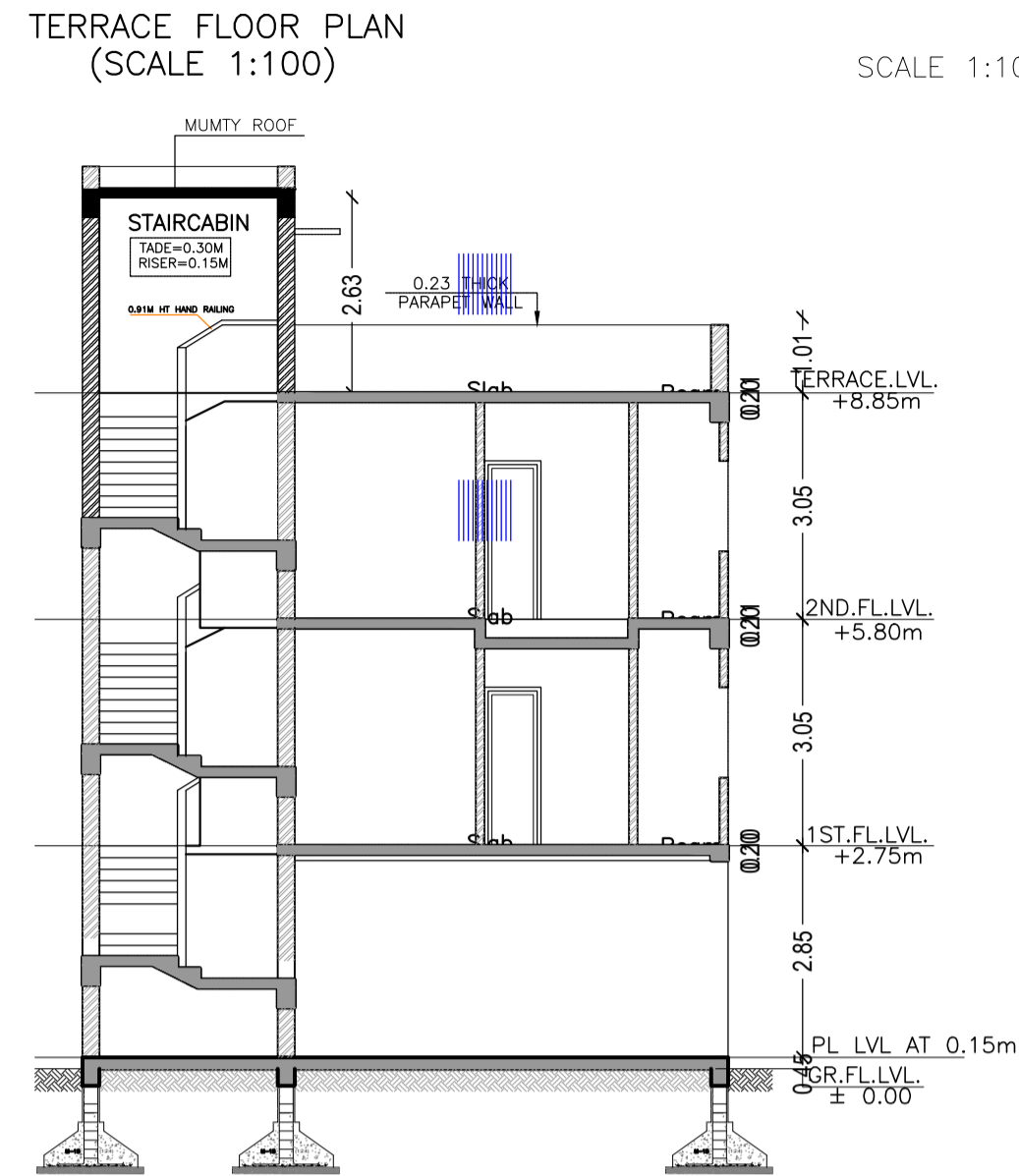

SECTION AT 'B-B' (SCALE 1:100)

Proposal Basic Information

Proposal File No.	JNAC/BP/0087/W11/2019
Owner Name	sri Bupendra kumar and others
Khata No	52
Plot No	1932
Village Name	SAKCHI
Use	Residential
SubUse	Bungalow/ Dwelling / Non Apartment

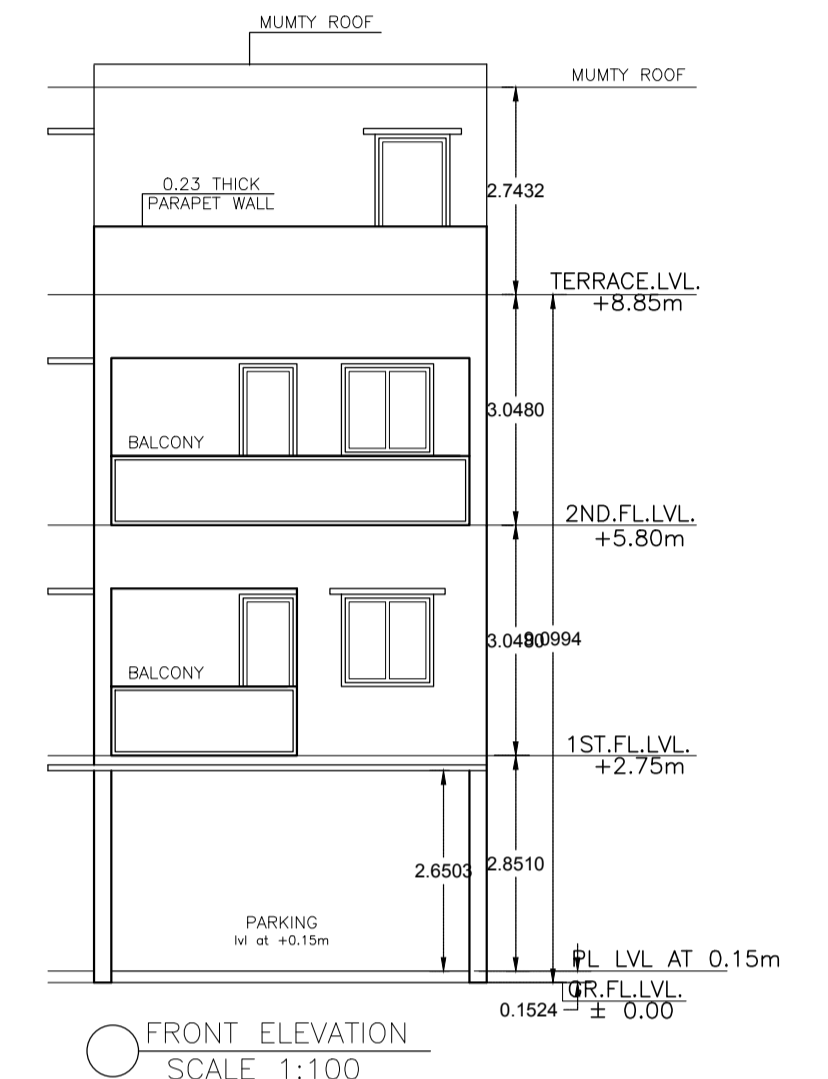

FRONT ELEVATION (SCALE 1:100)

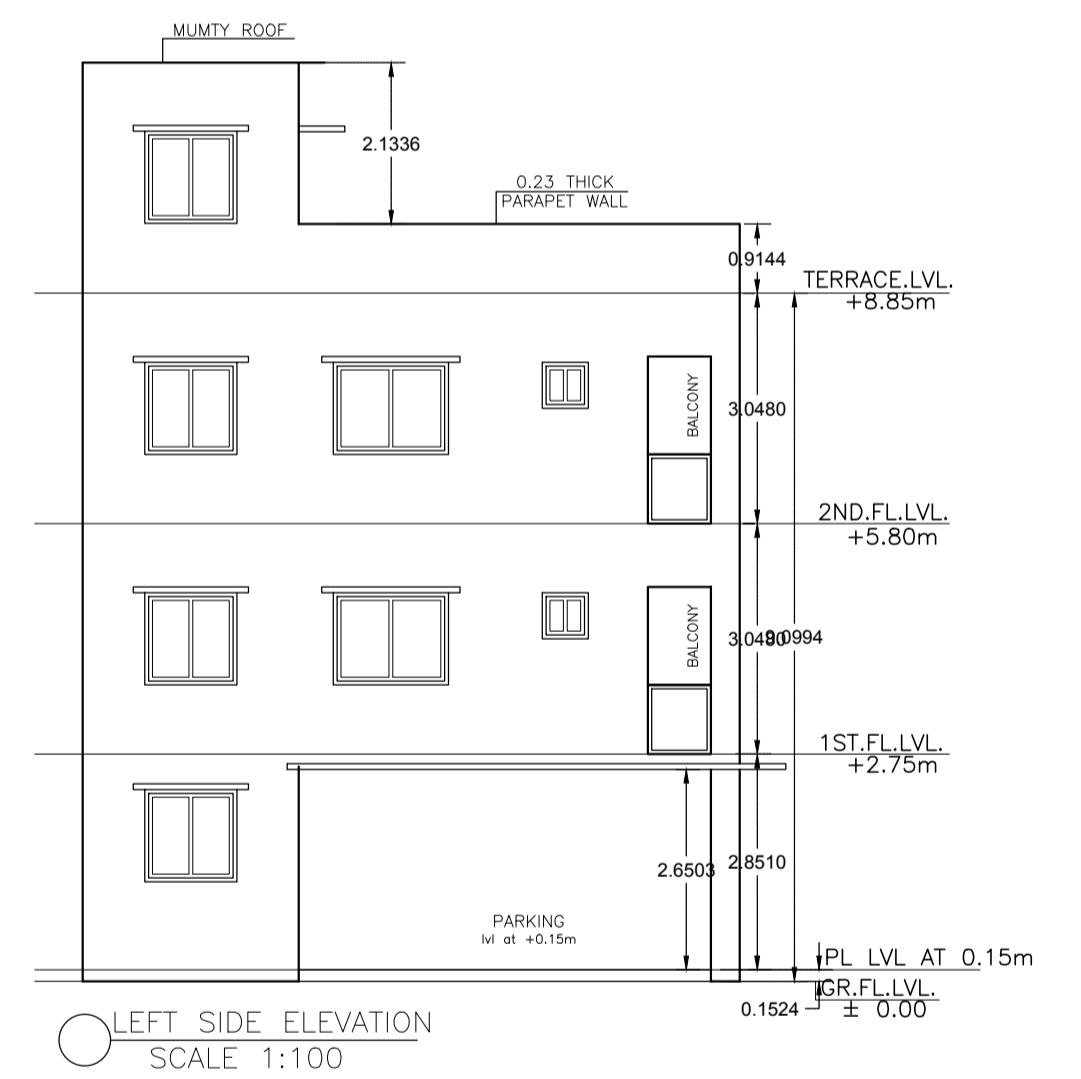
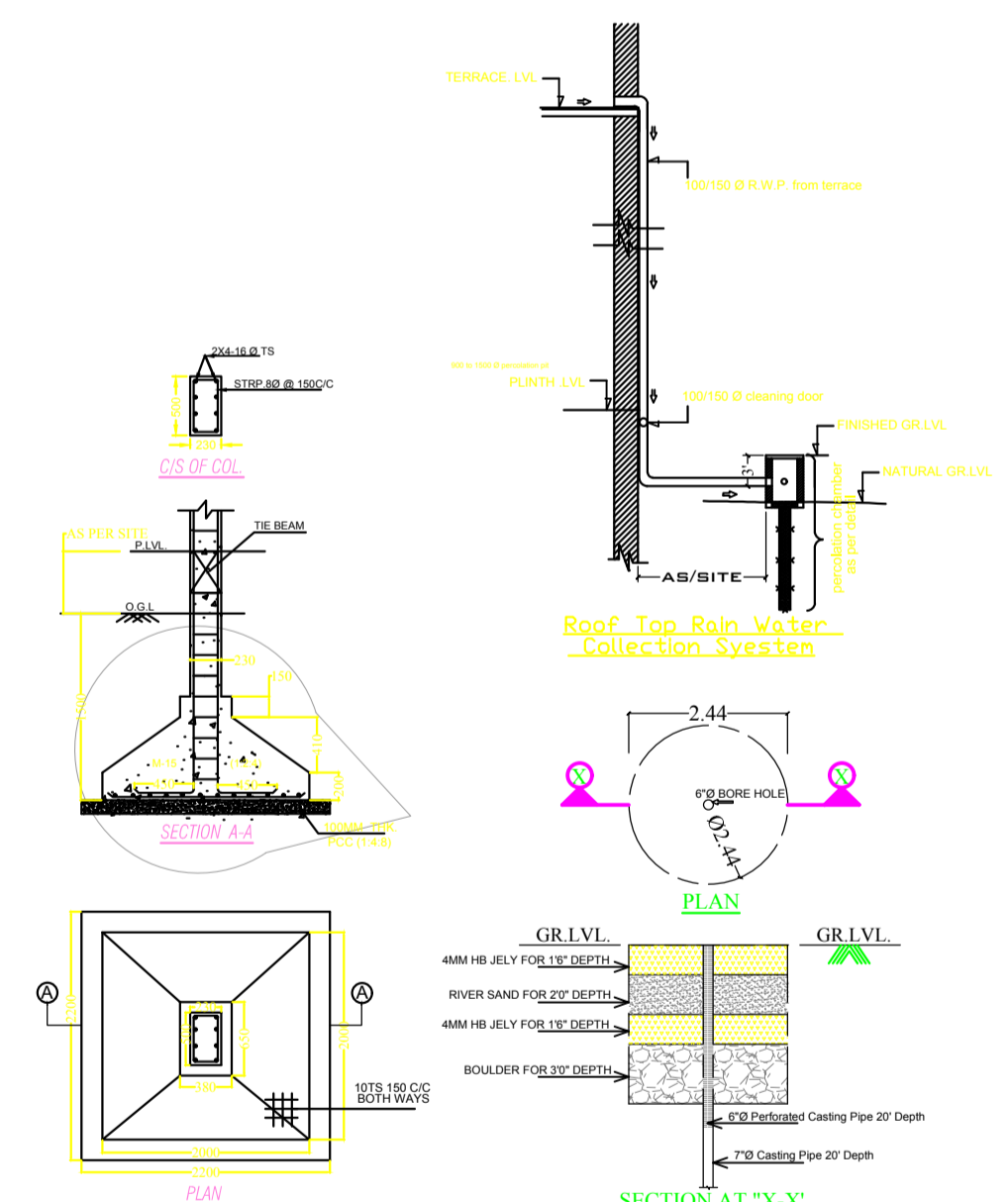

LEFT SIDE ELEVATION (SCALE 1:100)

Building :A (RESIDENTIAL)

Floor Name	Total Built Up Area (Sq.mt.)	Deductions (Area in Sq.mt.)		Proposed FAR Area (Sq.mt.)	Add Area in FAR (Sq.mt.)		Total FAR Area (Sq.mt.)	Total Consumed Additional FAR Area (Sq.mt.)	Trmt (No.)
		Parking	Resi.		Stair				
Ground Floor	45.16	29.80	3.98	11.38	15.36	15.36	01		
First Floor	45.18	0.00	45.18	0.00	45.18	45.18	00		
Second Floor	45.18	0.00	45.18	0.00	45.18	45.18	00		
Terrace Floor	0.00	0.00	0.00	0.00	0.00	0.00	00		
Total :	135.52	29.80	94.34	11.38	105.72	105.72	01		
Total Number of Same Buildings	1								
Total :	135.52	29.80	94.34	11.38	105.72	105.72	01		

SCHEDULE OF DOOR:

BUILDING NAME	NAME	LENGTH	HEIGHT	NOS
A (RESIDENTIAL)	D2	0.76	2.10	05
A (RESIDENTIAL)	D1	0.90	2.10	01
A (RESIDENTIAL)	D	1.16	2.10	02

SCHEDULE OF WINDOW/VENTILATION:

BUILDING NAME	NAME	LENGTH	HEIGHT	NOS
A (RESIDENTIAL)	V	0.90	0.90	03
A (RESIDENTIAL)		1.22	1.20	02
A (RESIDENTIAL)	W	1.52	1.20	02

UnitBUA Table for Building :A (RESIDENTIAL)

FLOOR	Name	UnitBUA Type	UnitBUA Area	Carpet Area	No. of Rooms	No. of Tenement
GROUND FLOOR PLAN	SPLIT A	FLAT	58.19	57.65	1	1
FIRST FLOOR PLAN	SPLIT A	FLAT	0.00	0.00	4	0
SECOND FLOOR PLAN	SPLIT A	FLAT	0.00	0.00	3	0
Total:	-	-	58.19	57.65	8	1

LTP NAME AND SIGNATURE	STRUCTURAL ENG'S NAME AND SIGNATURE	BUILDER NAME AND SIGNATURE	DIGITAL SIGNATURE
S M shahreyar JNAC/ARC/0004/2018			