

SITE PLAN (Scale - 1:200)

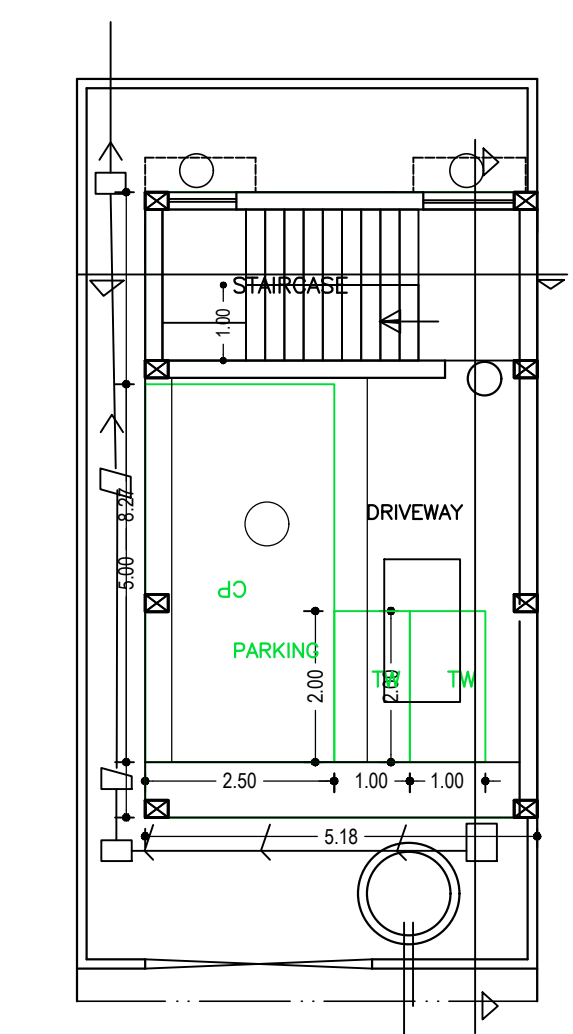

GROUND FLOOR PLAN (SCALE 1:100)

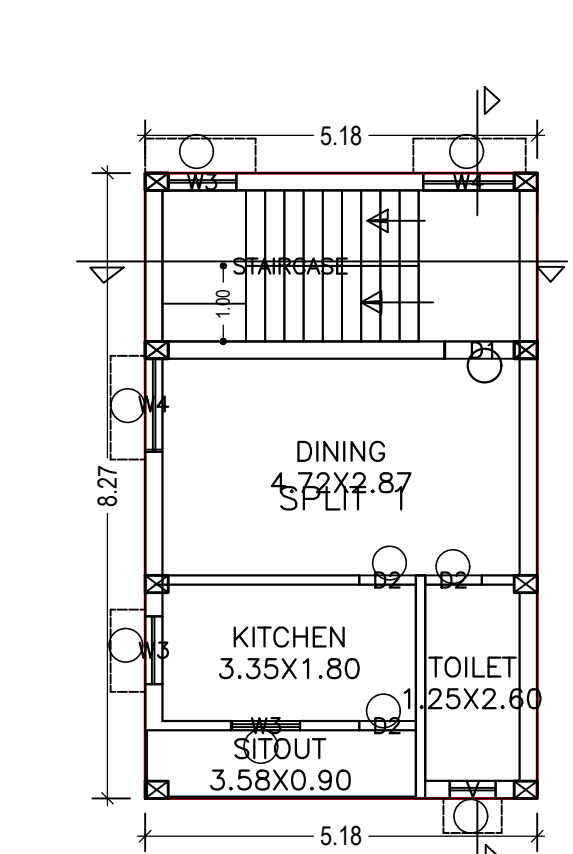

FIRST FLOOR PLAN (Proposed) (SCALE 1:100)

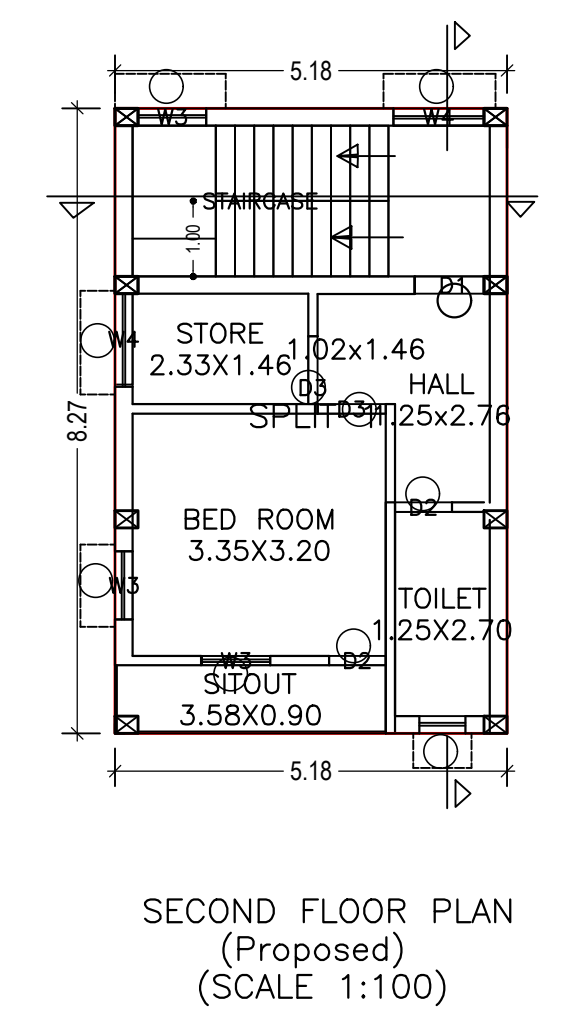

SECOND FLOOR PLAN (Proposed) (SCALE 1:100)

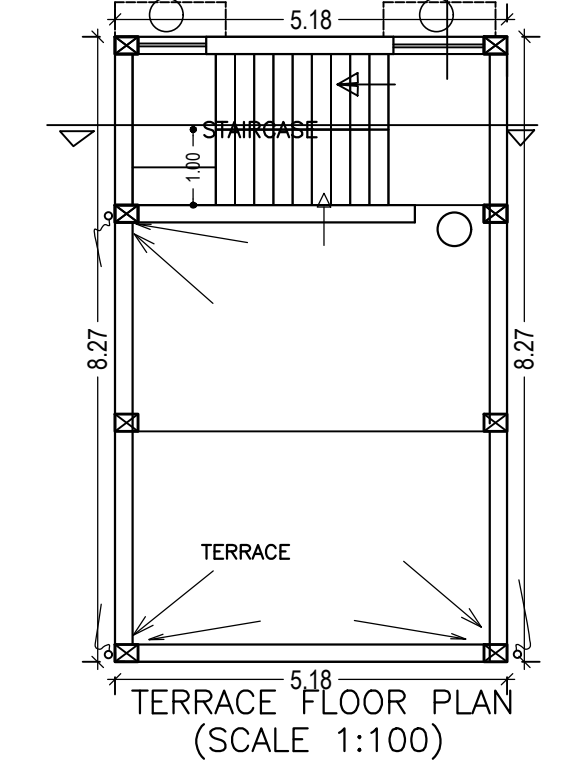

TERRACE FLOOR PLAN (SCALE 1:100)

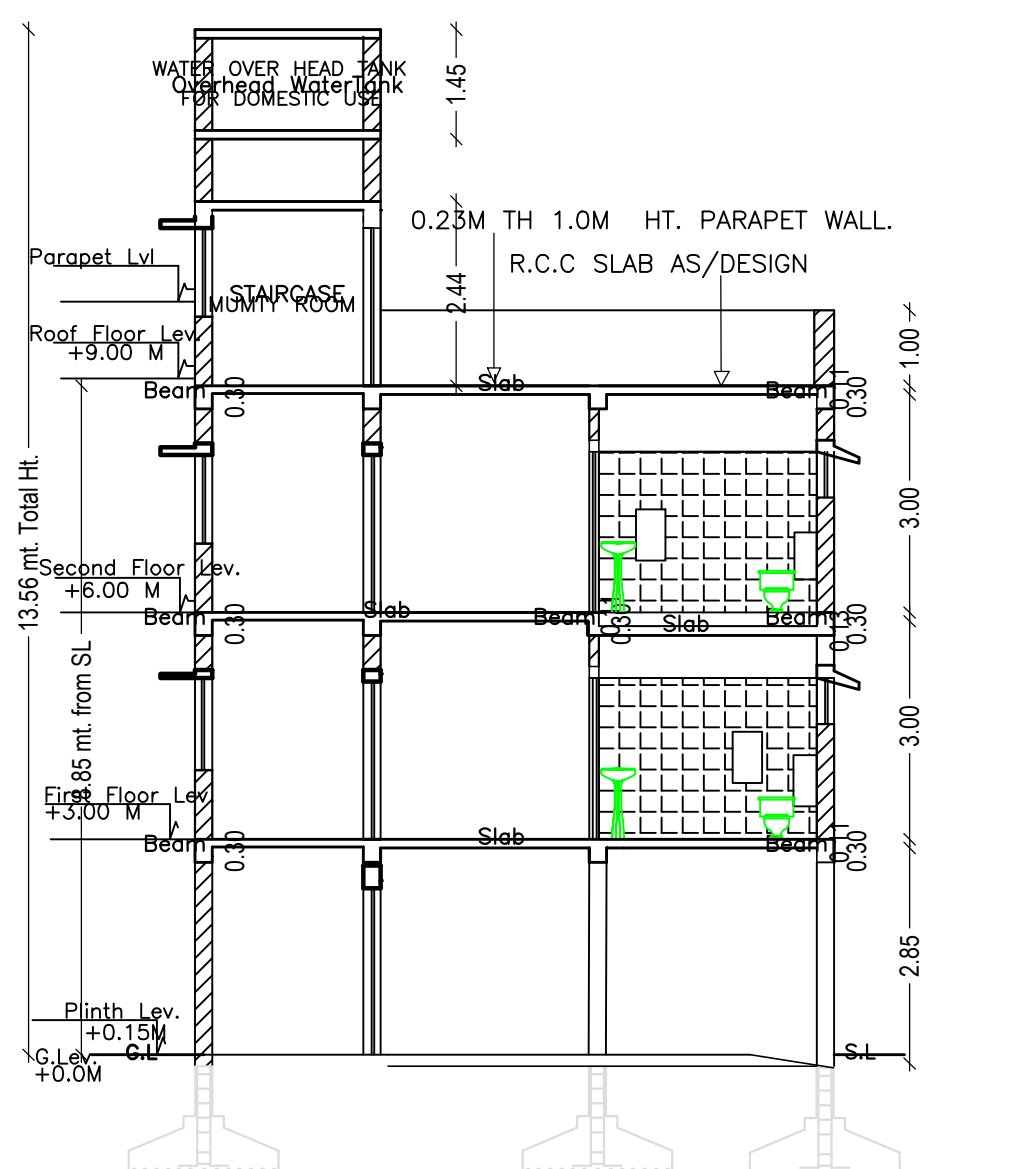

SECTION AT B-B SCALE-1:100

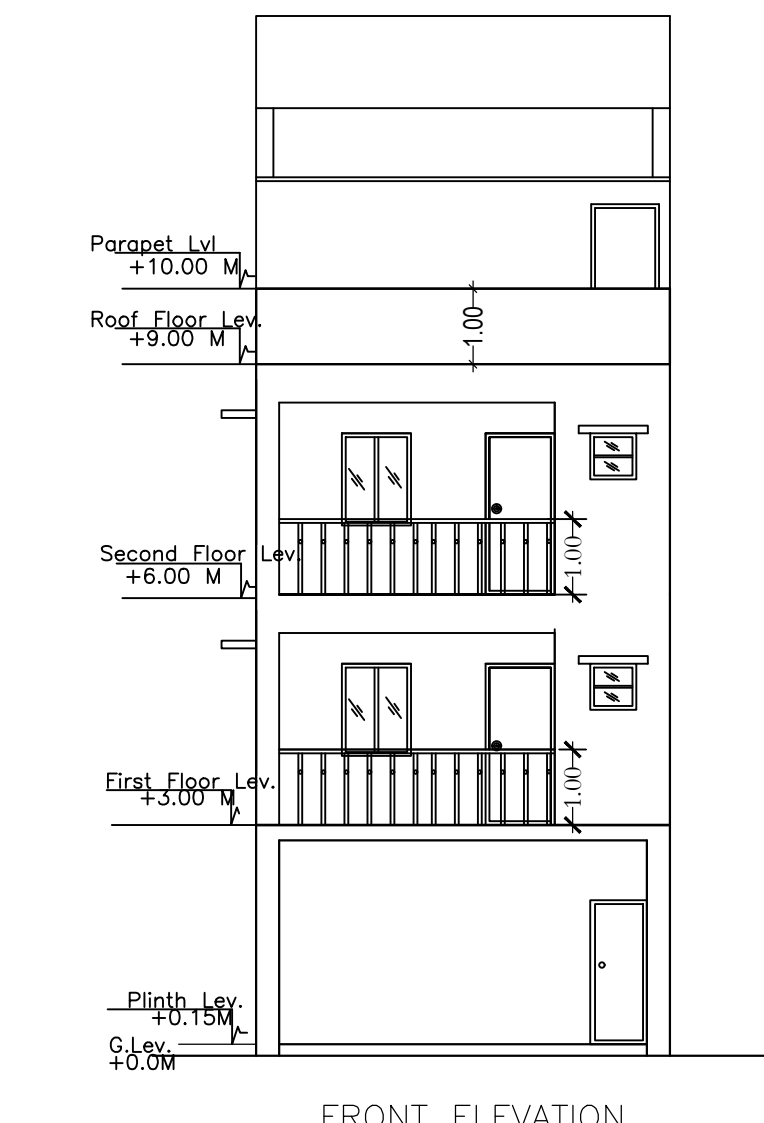

FRONT ELEVATION

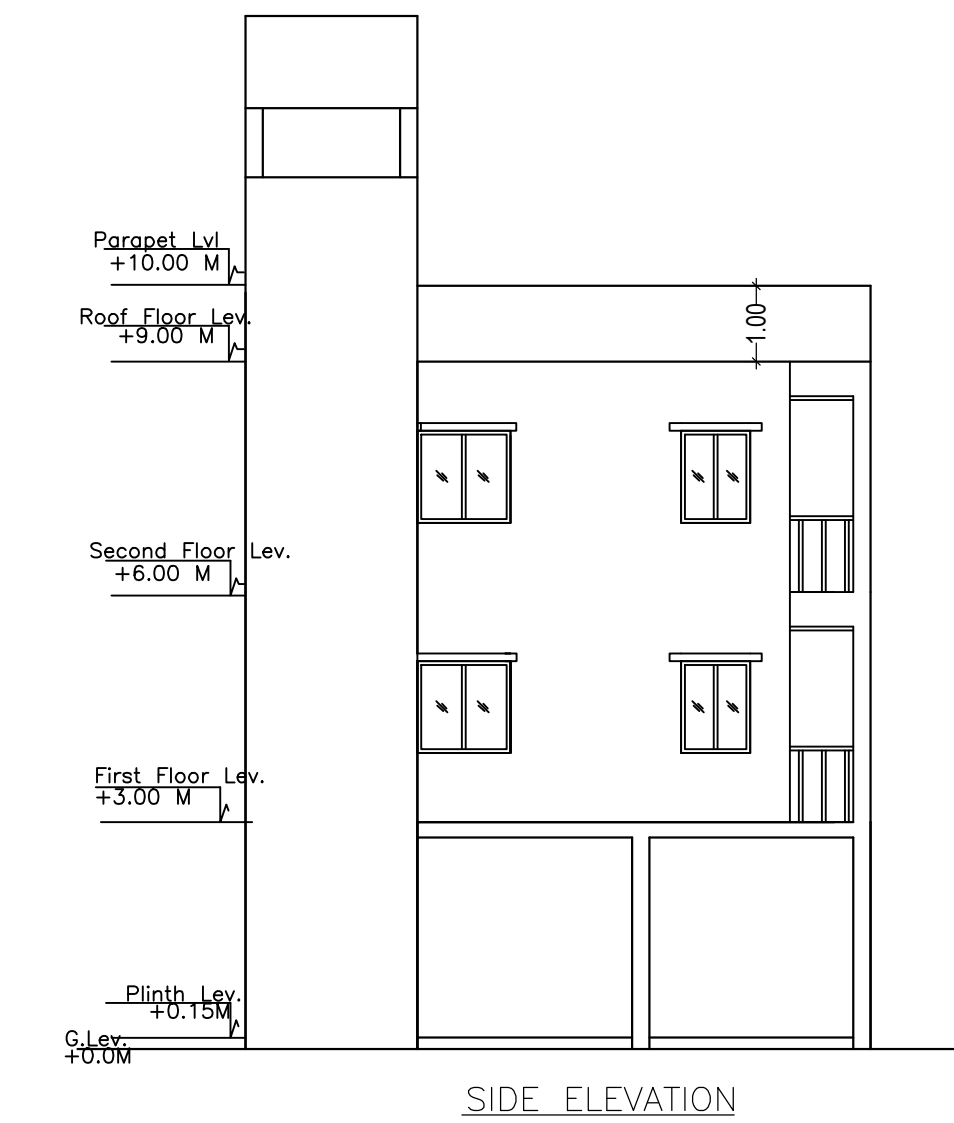

SIDE ELEVATION

FAR & Tenement Details (Table 4c-1)

| Building | No. of Same Bldg | Total Built Up Area (Sq.mt) | Deductions (Area in Sq.mt) | Proposed FAR Area (Sq.mt) | Add Area In FAR (Sq.mt) | Total FAR Area (Sq.mt) | Total Consumed Additional FAR Area (Sq.mt) | Tnmt (No.) |
|---------------|------------------|-----------------------------|----------------------------|---------------------------|-------------------------|------------------------|--|------------|
| A (RESIDENCE) | 1 | 141.14 | 48.62 | 85.76 | 6.76 | 92.52 | 92.52 | 01 |
| Grand Total : | 1 | 141.14 | 48.62 | 85.76 | 6.76 | 92.52 | 92.52 | 01 |

Proposal Basic Information

| | |
|-------------------|------------------------------------|
| Proposal File No. | JNAC/BP/016/W11/2019 |
| Owner Name | Syamal kumar Dhara |
| Khata No | Nil |
| Plot No | 135 |
| Village Name | Sitaramdera |
| Use | Residential |
| SubUse | Bungalow/ Dwelling / Non Apartment |

AREA STATEMENT JAMSHEDPUR NAC

| | |
|--|---|
| Region: JHARKHAND URBAN LOCAL BODIES | Plot Use: Residential |
| District: EAST SINGHBHUM | Plot SubUse: Bungalow/ Dwelling / Non Apartment |
| Authority: JAMSHEDPUR NAC | PlotNearby/ReligiousStructure: NA |
| Inward_No: JNAC/BP/016/W11/2019 | PlotSubPlotNo: 135 |
| Application Type: General Proposal | North: Plot No. - 136 |
| Project Type: Building Permission | South: Plot No. - 134 |
| Nature of Development: New | East: Road Width - 6.2 |
| Location of Development Area: New Area | West: Road Width - 2.4 |

| AREA DETAILS: | | SQ.MT. |
|--|----------------|--------|
| AREA OF PLOT (Minimum) | (A) | 74.24 |
| Deduction for NetPlot Area | | |
| Surrender Free of Cost | | 2.62 |
| Total | | 2.62 |
| NET AREA OF PLOT(Gross Plot Area - Deduction from Gross Plot area) | (A-Deductions) | 71.62 |
| Deduction for Balance Plot Area(from Gross Plot Area) | | |
| Surrender Free of Cost | | 2.62 |
| Common Plot | | 24.36 |
| Total | | 26.97 |
| BALANCE AREA OF PLOT(Net Plot Area - Recreational/Amenity space) | (A-Deductions) | 47.27 |
| PLOT AREA FOR COVERAGE(Net Plot Area) | (A-Deductions) | 71.62 |
| Plot Area for FAR (Net Plot Area + Road Widening Area) | (A-Deductions) | 74.24 |

| COVERAGE CHECK | | |
|---------------------------------------|--|-------|
| Permissible Coverage area (70.00 %) | | 50.13 |
| Proposed Coverage Area (59.87 %) | | 42.88 |
| Total Prop. Coverage Area (59.87 %) | | 42.88 |
| Balance coverage area (10.12 %) | | 7.25 |

| FAR CHECK | | |
|-------------------------|--|--------|
| Perm. FAR Area (1.80) | | 133.63 |
| Total Perm. FAR area | | 133.63 |
| Residential FAR | | 85.76 |
| Proposed FAR Area | | 92.52 |
| Total Proposed FAR Area | | 92.52 |
| Consumed FAR (Factor) | | 1.25 |
| Balance FAR Area | | 41.11 |

| BUILT UP AREA CHECK | | |
|-----------------------------|--------------------|--------|
| Total Proposed BuiltUp Area | | 141.14 |
| ARCHITECT (Regd) | SUMANA BASACK | |
| ENGINEER (Regd) | | |
| SUPERVISOR (Regd) | | |
| OWNER (Regd) | Syamal kumar Dhara | |
| DEVELOPMENT AUTHORITY | LOCAL BODY | |

| COLOR INDEX | |
|-----------------------------|------------|
| PLOT BOUNDARY | Black |
| ABUTTING ROAD | Green |
| PROPOSED CONSTRUCTION | Red |
| COMMON PLOT | Yellow |
| ROAD WIDENING AREA | Orange |
| EXISTING (To be retained) | Blue |
| EXISTING (To be demolished) | Light Blue |

Building :A (RESIDENCE)

| Floor Name | Total Built Up Area (Sq.mt) | Deductions (Area in Sq.mt) | Proposed FAR Area (Sq.mt) | Add Area In FAR (Sq.mt) | Total FAR Area (Sq.mt) | Total Consumed Additional FAR Area (Sq.mt) | Tnmt (No.) |
|--------------------------------|-----------------------------|----------------------------|---------------------------|-------------------------|------------------------|--|------------|
| Ground Floor | 55.38 | 48.62 | 0.00 | 6.76 | 6.76 | 6.76 | 00 |
| First Floor | 42.88 | 0.00 | 42.88 | 0.00 | 42.88 | 42.88 | 01 |
| Second Floor | 42.88 | 0.00 | 42.88 | 0.00 | 42.88 | 42.88 | 00 |
| Terrace Floor | 0.00 | 0.00 | 0.00 | 0.00 | 0.00 | 0.00 | 00 |
| Total : | 141.14 | 48.62 | 85.76 | 6.76 | 92.52 | 92.52 | 01 |
| Total Number of Same Buildings | 1 | | | | | | |
| Total : | 141.14 | 48.62 | 85.76 | 6.76 | 92.52 | 92.52 | 01 |

SCHEDULE OF DOOR:

| BUILDING NAME | NAME | LENGTH | HEIGHT | NOS |
|---------------|------|--------|--------|-----|
| A (RESIDENCE) | D2 | 0.75 | 2.10 | 05 |
| A (RESIDENCE) | D3 | 0.90 | 2.10 | 02 |
| A (RESIDENCE) | D1 | 1.00 | 2.10 | 02 |

SCHEDULE OF WINDOW/VENTILATION:

| BUILDING NAME | NAME | LENGTH | HEIGHT | NOS |
|---------------|------|--------|--------|-----|
| A (RESIDENCE) | V | 0.60 | 0.60 | 01 |
| A (RESIDENCE) | W3 | 0.90 | 1.20 | 06 |
| A (RESIDENCE) | W4 | 1.20 | 1.20 | 02 |

UnitBUA Table for Building :A (RESIDENCE)

| FLOOR | Name | UnitBUA Type | UnitBUA Area | Carpet Area | No. of Rooms | No. of Tenement |
|-------------------|---------|--------------|--------------|-------------|--------------|-----------------|
| FIRST FLOOR PLAN | SPLIT 1 | FLAT | 85.76 | 85.01 | 4 | 1 |
| SECOND FLOOR PLAN | SPLIT 1 | FLAT | 0.00 | 0.00 | 5 | 0 |
| Total: | - | - | 85.76 | 85.01 | 9 | 1 |

| LTP NAME AND SIGNATURE | STRUCTURAL ENG'S NAME AND SIGNATURE | BUILDER NAME AND SIGNATURE | DIGITAL SIGNATURE |
|-------------------------------------|-------------------------------------|----------------------------|-------------------|
| SUMANA BASACK JNAC/ARC/0011/2017 | | | |