

SITE PLAN

FAR & Tenement Details (Table 4c-1)

Building	No. of Same Bldg	Total Built Up Area (Sq.mt)	Deductions (Area in Sq.mt)		Proposed FAR Area (Sq.mt)	Add Area in FAR (Sq.mt)	Total FAR Area (Sq.mt)	Total Consumed Additional FAR Area (Sq.mt)	Tnmt (No.)
			Parking	Resi.					
A (BUILDING)	1	214.67	55.36	143.12	16.19	159.31	159.31	02	
Grand Total :	1	214.67	55.36	143.12	16.19	159.31	159.31	02	

Proposal Basic Information

Proposal File No.	JNAC/BP/0111/W11/2019
Owner Name	SRI ASHIM KUMAR CHAKRABORTY
Khata No	N/A
Plot No	HOLDING NO. - 318
Village Name	Sitaramdera
Use	Residential
SubUse	Other Residential Building

(Scale - 1:200)

Required Parking (Table 7a)

Building Name	Type	SubUse	Area (Sq.mt)	Units		Car		Visitors Car		TwoWheeler			
				Reqd.	Prop.	Reqd./Unit	Reqd.	Prop.	Reqd./Unit	Reqd.	Prop.		
A (BUILDING)	Residential	Residential Bldg/Apartment	> 0	1	2.00	1.00	2	-	-	-	-	-	
			> 0	1	2.00	-	-	-	-	-	1	2	-
			> 0	1	2.00	-	-	-	-	1	1	-	-
Total :			-	-	-	2	2	-	1	1	-	2	2

Parking Check (Table 7b)

Vehicle Type	Reqd.		Prop.	
	No.	Area	No.	Area
Car	-	-	1	12.50
Two Stack Car	-	-	1	12.50
Total Car	2	25.00	2	25.00
Visitor's Car Parking	-	-	1	12.50
Total Visitor Parking	1	12.50	1	12.50
TwoWheeler	-	-	2	4.00
Total TwoWheeler	2	4.00	2	4.00
Other Parking	-	-	-	26.36
Total		41.50		84.36

AREA STATEMENT	VERSION NO. : 1.0.42		
JAMSHEDPUR NAC	VERSION DATE: 29/04/2019		
PROJECT DETAIL:			
Region: JHARKHAND URBAN	Plot Use: Residential		
LOCAL BODIES	Plot SubUse: Other Residential Building		
District: EAST SINGHBHUM	PlotNearby/ReligiousStructure: NA		
Authority: JAMSHEDPUR NAC	PlotNearby/ReligiousStructure: NA		
Inward No: JNAC/BP/0111/W11/2019	Plot/SubPlot No: HOLDING NO. - 318		
Application Type: General Proposal	North: Road Width - 6.10		
Project Type: Building Permission	South: CTS No. - 2.9M WIDE ALLEY		
Nature of Development: New	East: CTS No. - OTHERS PLOT		
Location of Development Area: Old Area	West: CTS No. - OTHERS PLOT		
AREA DETAILS:			
AREA OF PLOT (Minimum)	(A)	SQ.MT.	111.42
NET AREA OF PLOT(Gross Plot Area - Deduction from Gross Plot area)	(A-Deductions)		111.42
Deduction for Balance Plot Area(from Gross Plot Area)			
Common Plot			13.03
Total			13.03
BALANCE AREA OF PLOT(Net Plot Area - Recreational/Amenity spaces)	(A-Deductions)		98.39
PLOT AREA FOR COVERAGE(Net Plot Area)	(A-Deductions)		111.42
Plot Area for FAR (Net Plot Area + Road Widening Area)	(A-Deductions)		111.42
COVERAGE CHECK			
Permissible Coverage area (70.00 %)			77.99
Proposed Coverage Area (64.23 %)			71.56
Total Prop. Coverage Area (64.23 %)			71.56
Balance coverage area (5.77 %)			6.43
FAR CHECK			
Perm. FAR Area (2.50)			278.55
Total Perm. FAR area			278.55
Residential FAR			143.12
Proposed FAR Area			159.31
Total Proposed FAR Area			159.31
Consumed FAR (Factor)			1.43
Balance FAR Area			119.24
BUILT UP AREA CHECK			
Total Proposed BuiltUp Area			214.67
ARCHITECT (Regd)	SATISH KUMAR		
ENGINEER (Regd)			
SUPERVISOR (Regd)			
OWNER (Regd)	SRI ASHIM KUMAR CHAKRABORTY		
DEVELOPMENT AUTHORITY		LOCAL BODY	

COLOR INDEX	
PLOT BOUNDARY	
ABUTTING ROAD	
PROPOSED CONSTRUCTION	
COMMON PLOT	
ROAD WIDENING AREA	
EXISTING (To be retained)	
EXISTING (To be demolished)	

Buildingwise Floor FAR Details

Floor Name	A (BUILDING)		Total	
	Proposed Built Up Area (Sq.mt)	Proposed FAR Area (Sq.mt)	Total Proposed Built Up Area (Sq.mt)	Total FAR Area (Sq.mt)
Parking Floor	71.55	16.19	71.55	16.19
First Floor	71.56	71.56	71.56	71.56
Second Floor	71.56	71.56	71.56	71.56
Terrace Floor	0.00	0.00	0.00	0.00
Total :	214.67	159.31	214.67	159.31

Building USE/SUBUSE Details

Building Name	Building Use	Building SubUse	Building Structure
A (BUILDING)	Residential	Residential Bldg/Apartment	Non-Highrise

LTP NAME AND SIGNATURE	STRUCTURAL ENG'S NAME AND SIGNATURE	BUILDER NAME AND SIGNATURE	DIGITAL SIGNATURE
SATISH KUMAR JNAC/DFTMN/0004/2017			

Proposal Basic Information	
Proposal File No.	JNAC/BP/0111/W11/2019
Owner Name	SRI ASHIM KUMAR CHAKRABORTY
Khata No	N/A
Plot No	HOLDING NO. - 318
Village Name	Sitaramdera
Use	Residential
SubUse	Other Residential Building

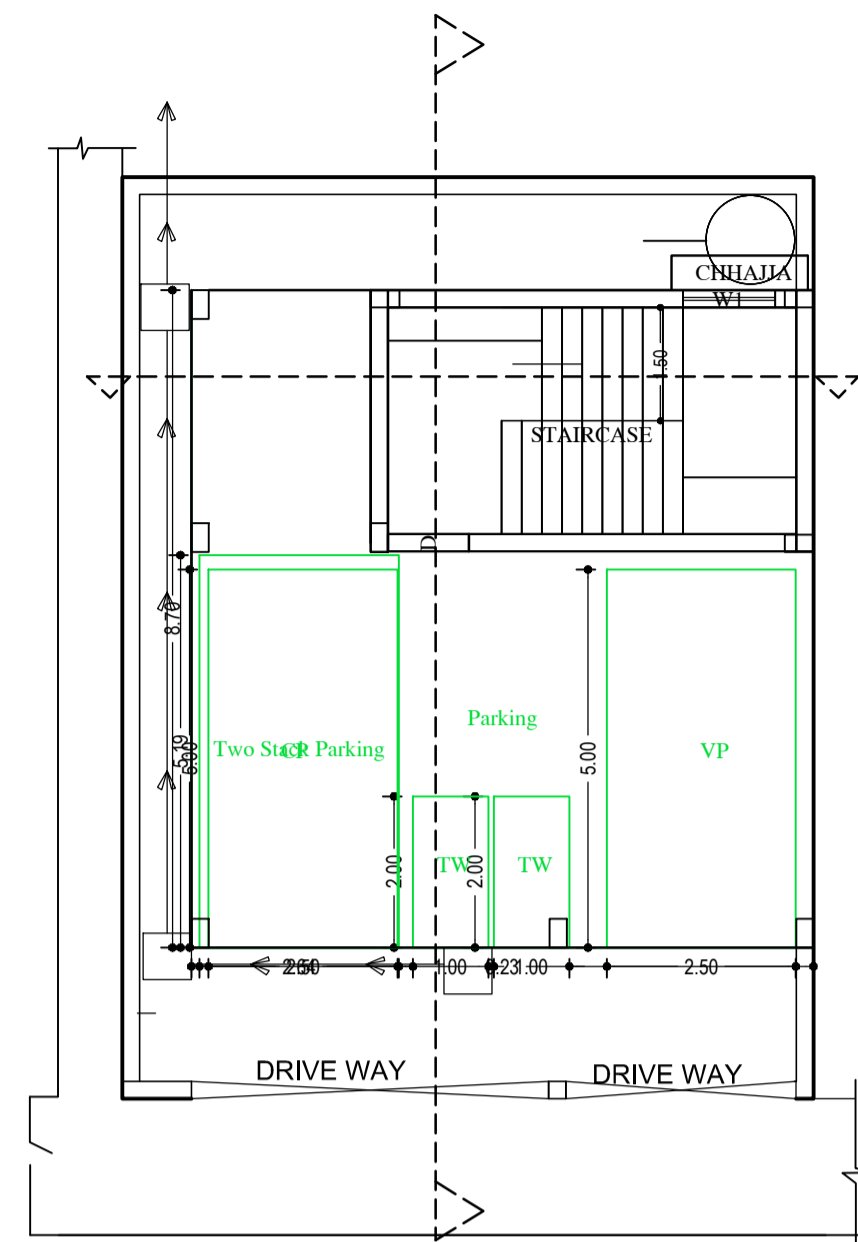

PARKING FLOOR PLAN (SCALE 1:100)

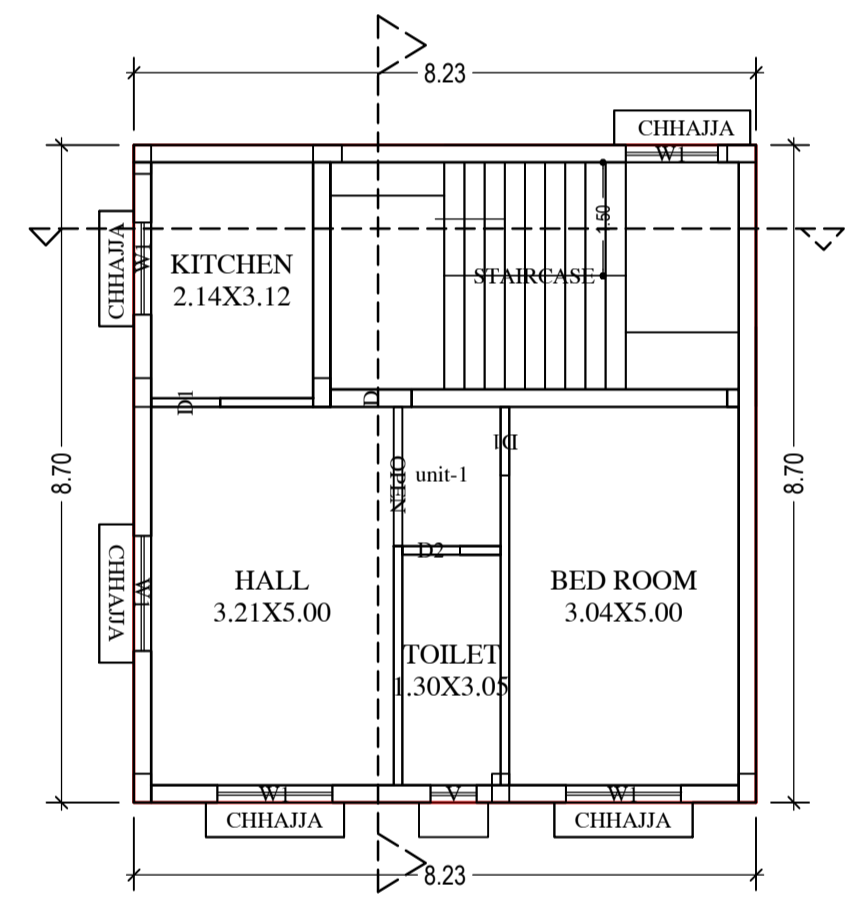

FIRST FLOOR PLAN (Proposed) (SCALE 1:100)

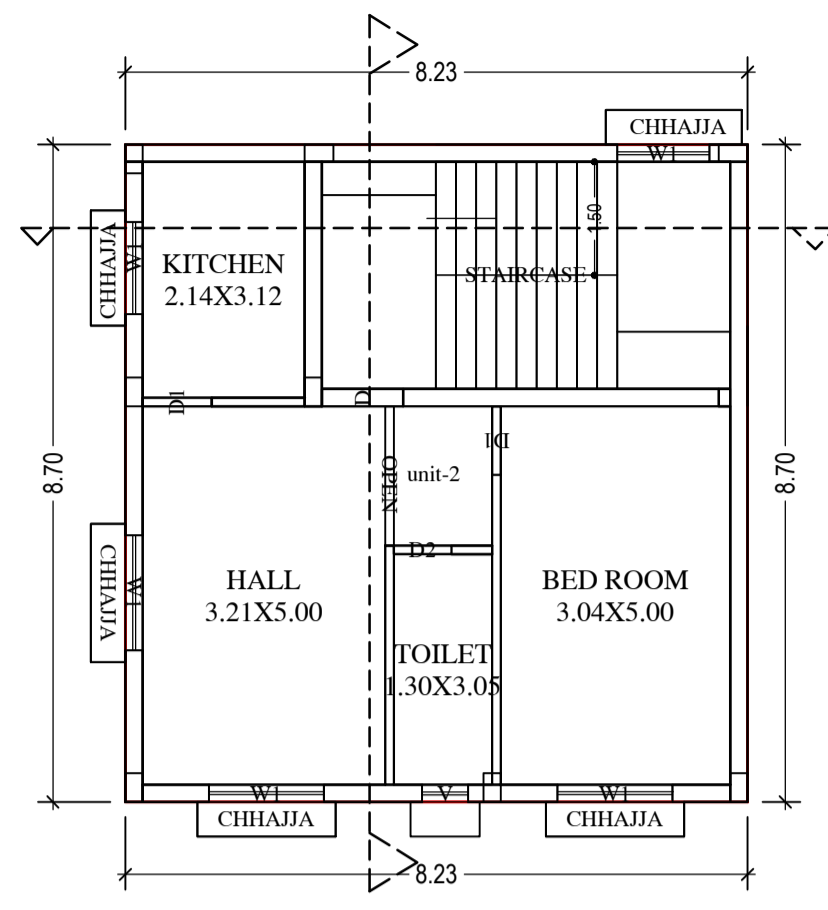

SECOND FLOOR PLAN (Proposed) (SCALE 1:100)

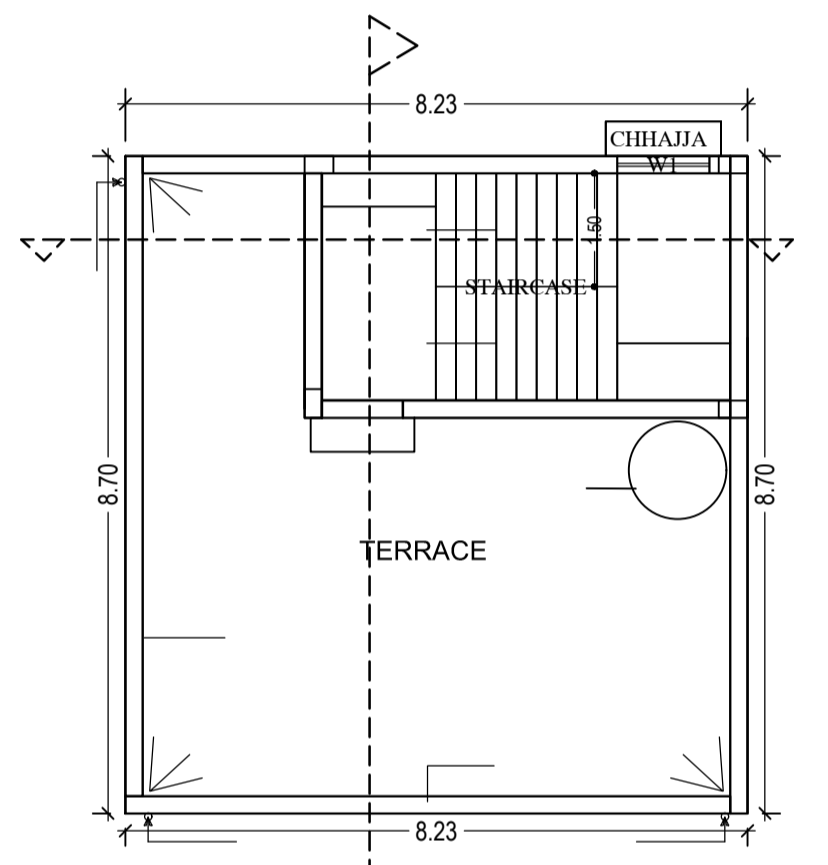

TERRACE FLOOR PLAN (SCALE 1:100)

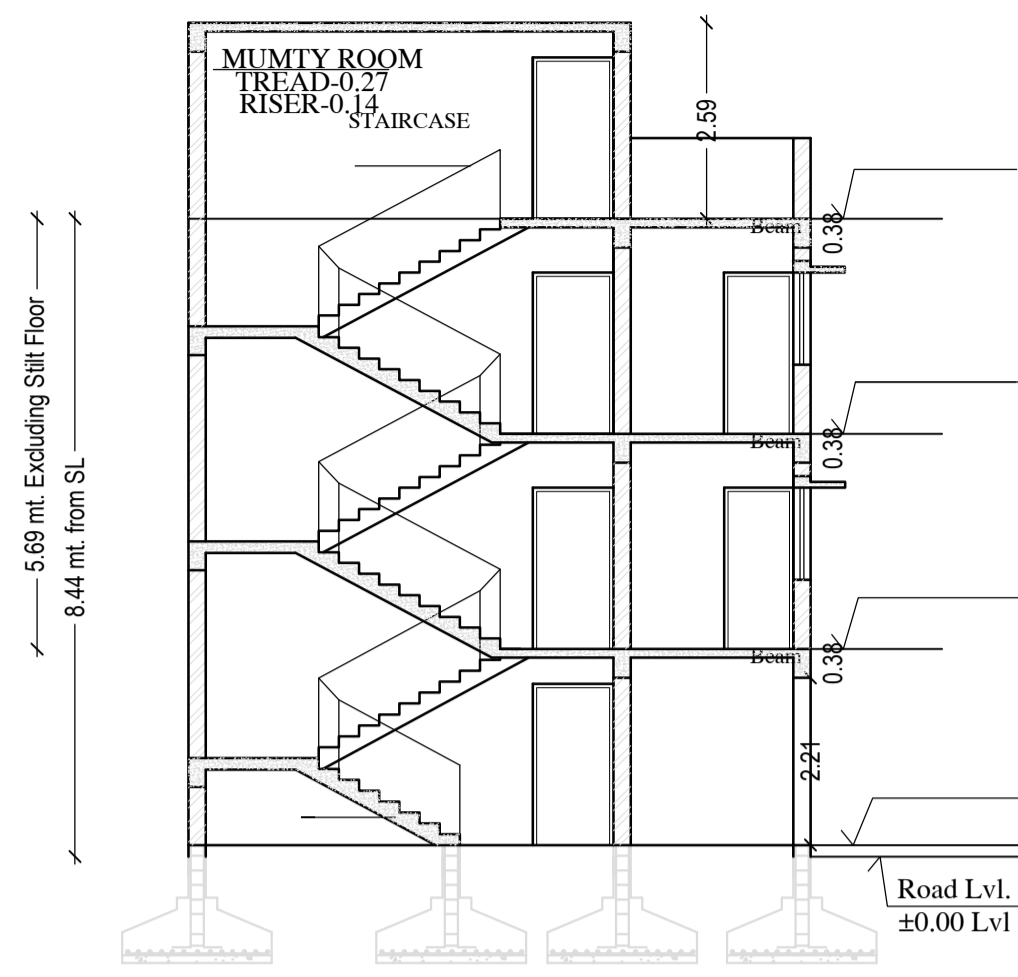

SECTION AT X-X (SCALE 1:100)

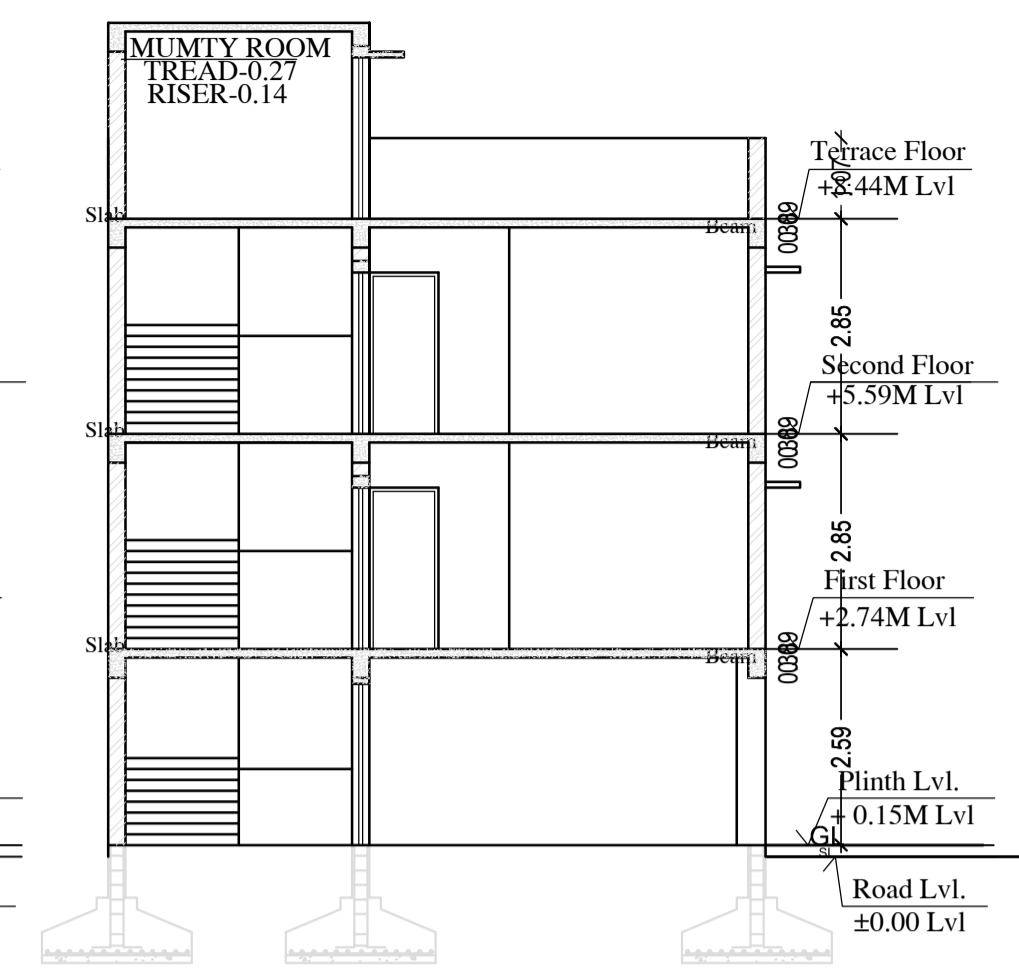

SECTION AT Y-Y (SCALE 1:100)

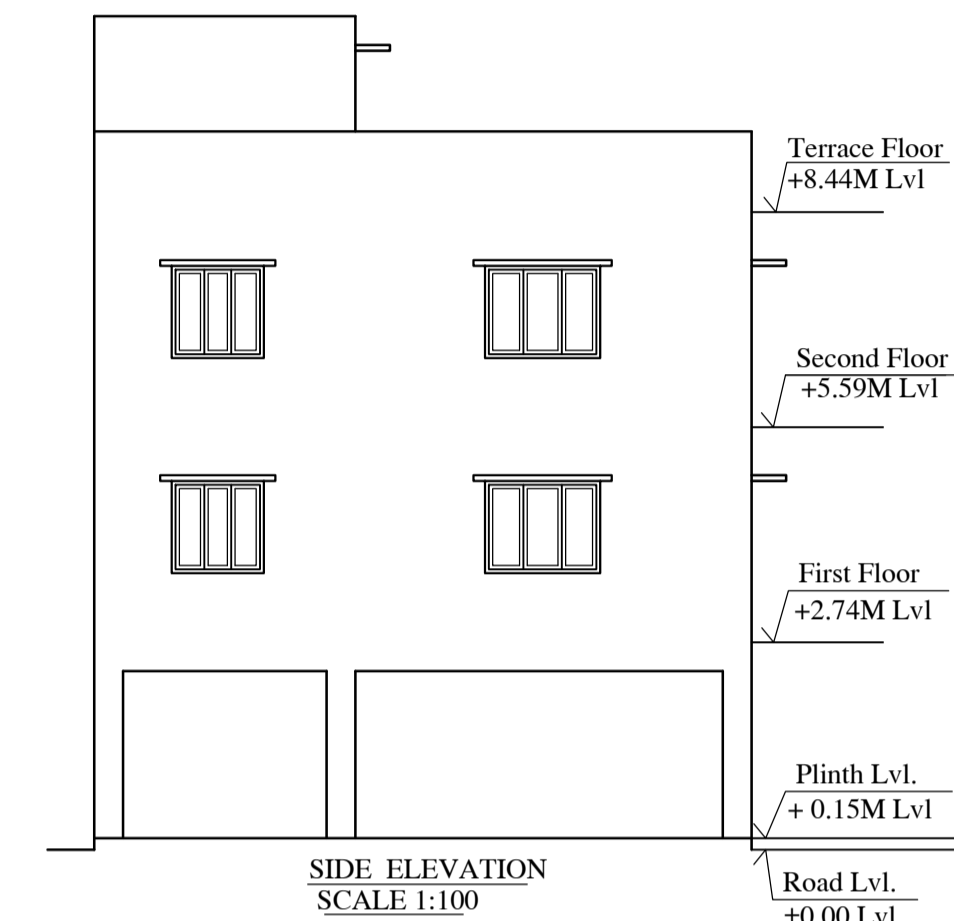

SIDE ELEVATION (SCALE 1:100)

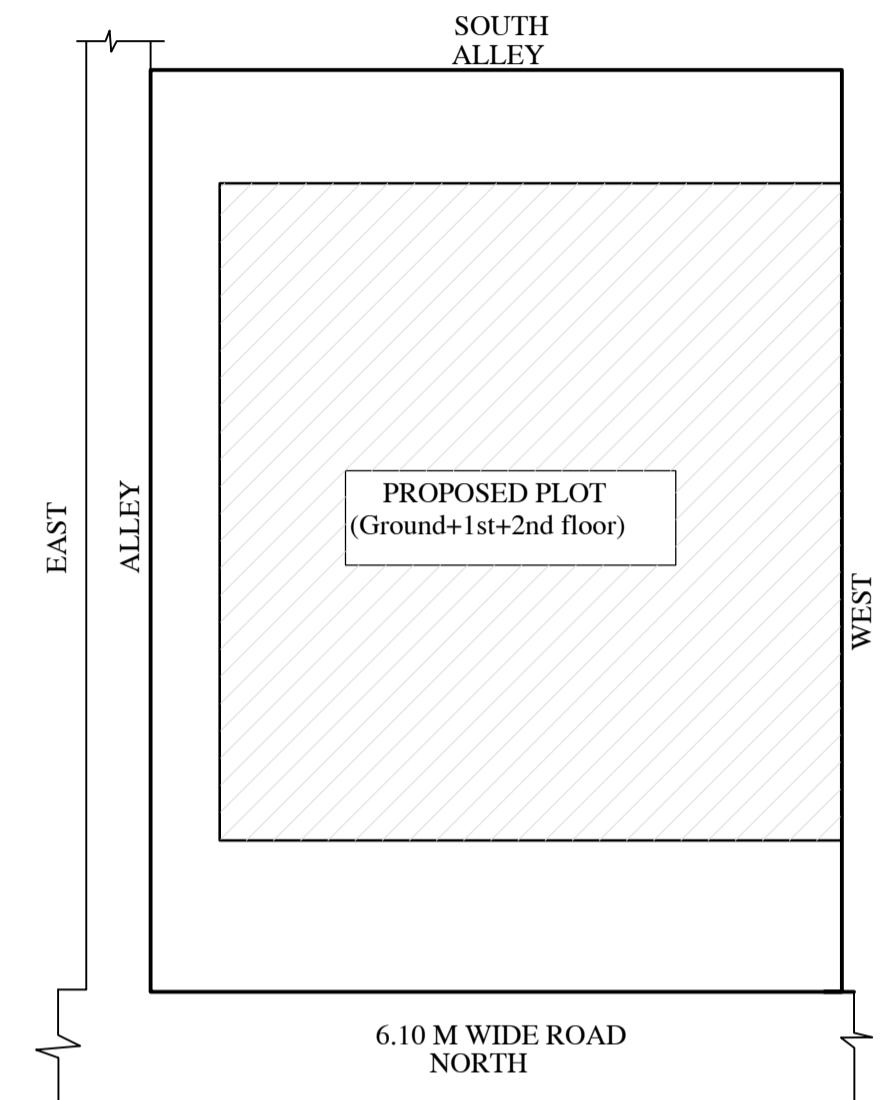

SITE PLAN (SCALE 1:100)

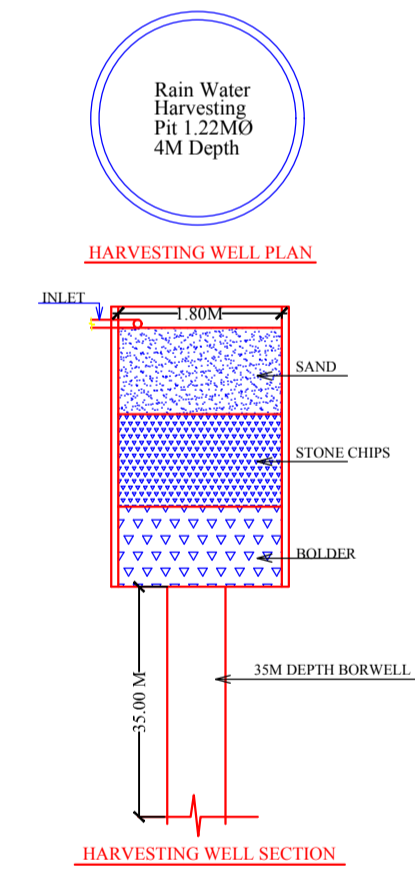

HARVESTING WELL SECTION

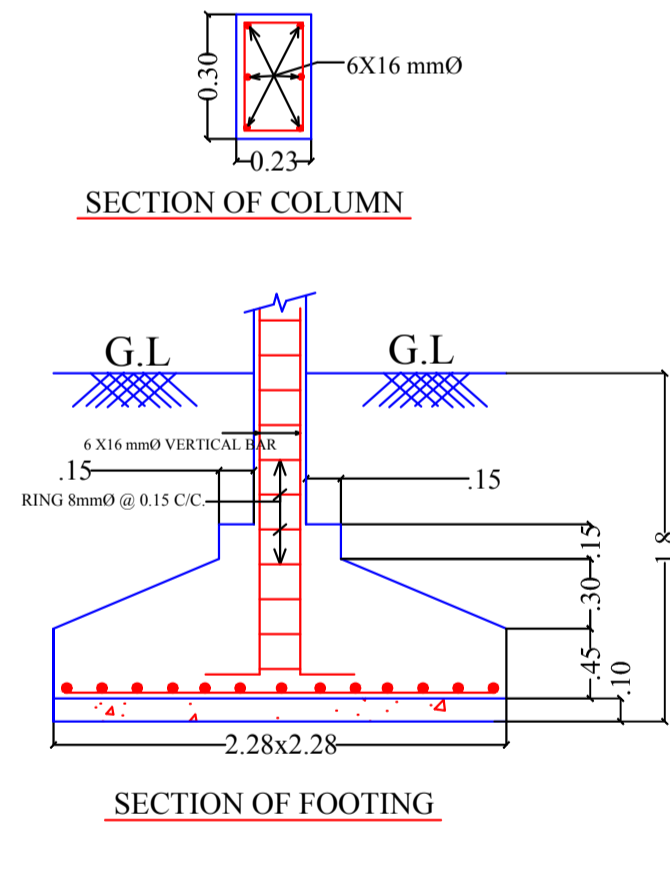

SECTION OF FOOTING

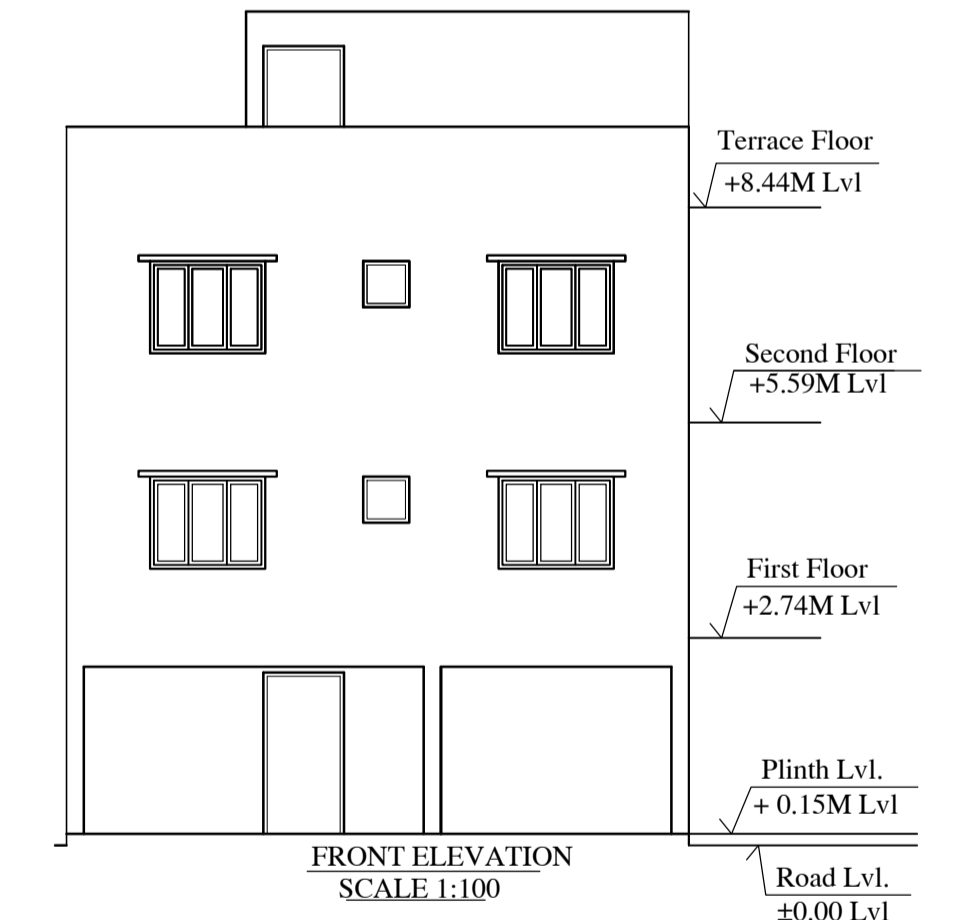

FRONT ELEVATION (SCALE 1:100)

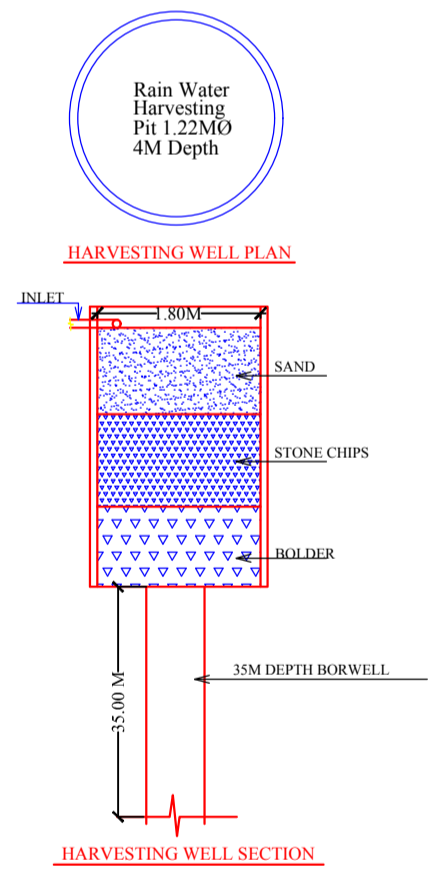

HARVESTING WELL SECTION

Building :A (BUILDING)

Floor Name	Total Built Up Area (Sq.mt.)	Deductions (Area in Sq.mt.)		Proposed FAR Area (Sq.mt.)		Add Area in FAR (Sq.mt.)	Total FAR Area (Sq.mt.)	Total Consumed Additional FAR Area (Sq.mt.)	Trmt (No.)
		Parking	Resi.	Stair	Stair				
Parking Floor	71.55	55.36	0.00	16.19	16.19	16.19	16.19	00	
First Floor	71.56	0.00	71.56	0.00	71.56	71.56	71.56	01	
Second Floor	71.56	0.00	71.56	0.00	71.56	71.56	71.56	01	
Terrace Floor	0.00	0.00	0.00	0.00	0.00	0.00	0.00	00	
Total :	214.67	55.36	143.12	16.19	159.31	159.31	159.31	02	
Total Number of Same Buildings	1								
Total :	214.67	55.36	143.12	16.19	159.31	159.31	159.31	02	

SCHEDULE OF DOOR:

BUILDING NAME	NAME	LENGTH	HEIGHT	NOS
A (BUILDING)	D2	0.76	2.13	02
A (BUILDING)	D1	0.91	2.13	04
A (BUILDING)	D	1.07	2.13	02
A (BUILDING)	OPEN	1.84	2.13	02

SCHEDULE OF WINDOW/VENTILATION:

BUILDING NAME	NAME	LENGTH	HEIGHT	NOS
A (BUILDING)	V	0.61	0.61	02
A (BUILDING)	W1	1.22	1.22	06
A (BUILDING)	W1	1.52	1.22	06

UnitBUA Table for Building :A (BUILDING)

FLOOR	Name	UnitBUA Type	UnitBUA Area	Carpet Area	No. of Rooms	No. of Tenement
FIRST FLOOR PLAN	unit-1	FLAT	71.56	60.73	4	1
SECOND FLOOR PLAN	unit-2	FLAT	71.56	60.73	4	1
Total:	-	-	143.12	121.46	8	2

LTP NAME AND SIGNATURE	STRUCTURAL ENG'S NAME AND SIGNATURE	BUILDER NAME AND SIGNATURE	DIGITAL SIGNATURE
SATISH KUMAR JNAC/DFTMN/0004/2017			