

Proposal Basic Information	
Proposal File No.	JNAC/BP/0117/W2/2019
Owner Name	SRI MANIK CHANDRA DAS AND RUP CHANDRA DAS
Khata No	NIL
Plot No	1382-E
Village Name	SONARI
Use	Residential
SubUse	Semidetached

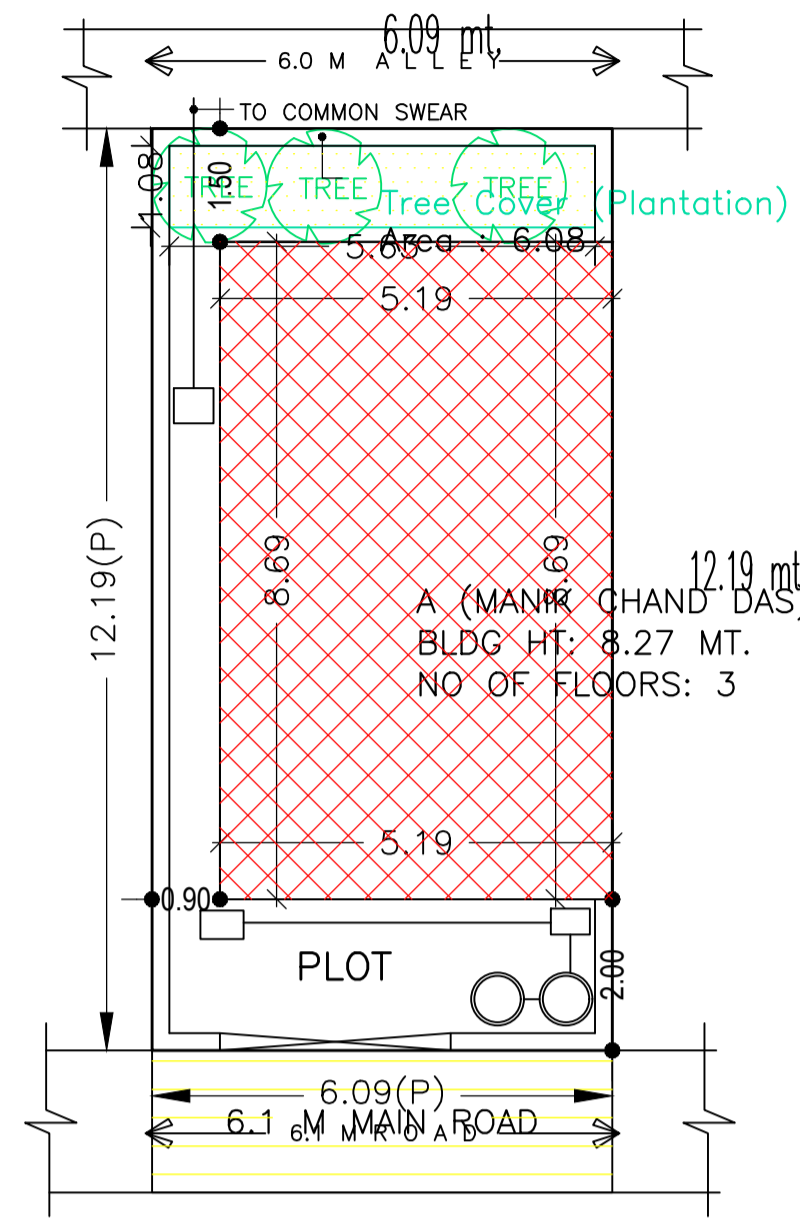

SITE PLAN
SCALE-1:100

SITE PLAN

AREA STATEMENT JAMSHEDPUR NAC	VERSION NO.: 1.0.42 VERSION DATE: 29/04/2019
PROJECT DETAIL:	
Region: JHARKHAND URBAN LOCAL BODIES	Plot Use: Residential
District: EAST SINGHBHUM	Plot SubUse: Semidetached
Authority: JAMSHEDPUR NAC	PlotNearbyReligiousStructure: NA
Inward_No: JNAC/BP/0117/W2/2019	Plot/SubPlot No: 1382-E
Application Type: General Proposal	North: Road Width - 4.5 M
Project Type: Building Permission	South: Road Width - 9.0 M
Nature of Development: New	East: Plot No. - E/1382
Location of Development Area: Old Area	West: Plot No. - NIL
AREA DETAILS:	
AREA OF PLOT (Minimum)	(A) 74.27 SQ.MT.
NET AREA OF PLOT(Gross Plot Area - Deduction from Gross Plot area)	(A-Deductions) 74.27
Deduction for Balance Plot Area(from Gross Plot Area)	
Common Plot	6.08
Total	6.08
BALANCE AREA OF PLOT(Net Plot Area - Recreational/Amenity space)	(A-Deductions) 68.18
PLOT AREA FOR COVERAGE(Net Plot Area)	(A-Deductions) 74.27
Plot Area for FAR (Net Plot Area + RoadWidening Area)	(A-Deductions) 74.27
COVERAGE CHECK	
Permissible Coverage area (70.00 %)	51.99
Proposed Coverage Area (60.77 %)	45.13
Total Prop. Coverage Area (60.77 %)	45.13
Balance coverage area (9.24 %)	6.86
FAR CHECK	
Perm. FAR Area (2.50)	185.67
Total Perm. FAR area	185.67
Residential FAR	90.25
Proposed FAR Area	101.61
Total Proposed FAR Area	101.61
Consumed FAR (Factor)	1.37
Balance FAR Area	84.06
BUILT UP AREA CHECK	
Total Proposed BuiltUp Area	135.39
ARCHITECT (Regd)	Shreyashi Haldar
ENGINEER (Regd)	
SUPERVISOR (Regd)	
OWNER (Regd)	SRI MANIK CHANDRA DAS AND RUP CHANDRA DAS
DEVELOPMENT AUTHORITY	LOCAL BODY

COLOR INDEX	
PLOT BOUNDARY	[Red Line]
ABUTTING ROAD	[Green Line]
PROPOSED CONSTRUCTION	[Yellow Line]
COMMON PLOT	[Blue Line]
ROAD WIDENING AREA	[Orange Line]
EXISTING (To be retained)	[Grey Line]
EXISTING (To be demolished)	[Black Line]

Buildingwise Floor FAR Details

Floor Name	Building Name		Total	
	Proposed Built Up Area (Sq.mt.)	Proposed FAR Area (Sq.mt.)	Total Proposed Built Up Area (Sq.mt.)	Total FAR Area (Sq.mt.)
Parking Floor	45.13	11.35	45.13	11.35
First Floor	45.13	45.13	45.13	45.13
Second Floor	45.13	45.13	45.13	45.13
Terrace Floor	0.00	0.00	0.00	0.00
Total :	135.39	101.61	135.39	101.61

Building USE/SUBUSE Details

Building Name	Building Use	Building SubUse	Building Structure
A (MANIK CHAND DAS)	Residential	Semidetached	Non-Highrise

FAR & Tenement Details (Table 4c-1)

Building	No. of Same Bldg	Total Built Up Area (Sq.mt.)	Deductions (Area in Sq.mt.)	Proposed FAR Area (Sq.mt.)	Add Area In FAR (Sq.mt.)	Total FAR Area (Sq.mt.)	Total Consumed Additional FAR Area (Sq.mt.)	Tnmt (No.)
A (MANIK CHAND DAS)	1	135.39	33.78	90.26	11.35	101.61	101.61	01
Grand Total :	1	135.39	33.78	90.26	11.35	101.61	101.61	01

LTP NAME AND SIGNATURE	STRUCTURAL ENG'S NAME AND SIGNATURE	BUILDER NAME AND SIGNATURE	DIGITAL SIGNATURE
Shreyashi Haldar JNAC/DFTMN/0009/2016			

Proposal Basic Information

Proposal File No.	JNAC/BP/0117/W2/2019
Owner Name	SRI MANIK CHANDRA DAS AND RUP CHANDRA DAS
Khata No	NIL
Plot No	1382-E
Village Name	SONARI
Use	Residential
SubUse	Semidetached

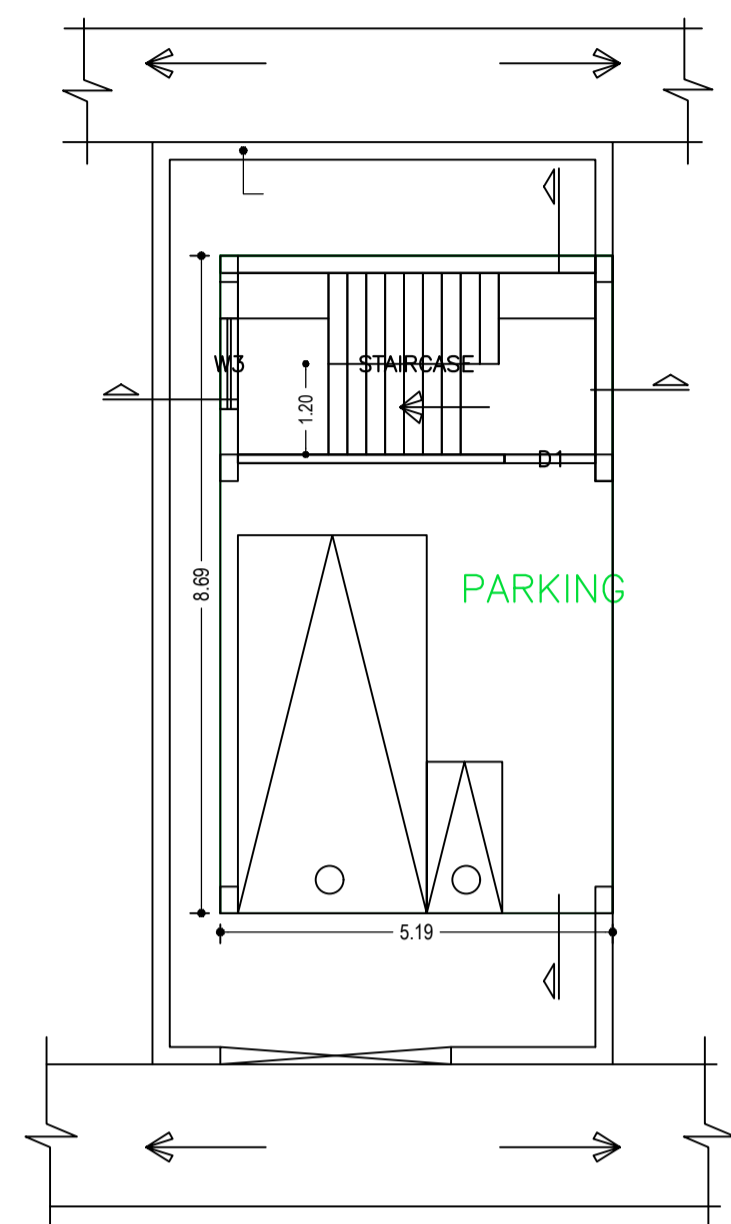

PARKING FLOOR PLAN
(SCALE 1:100)

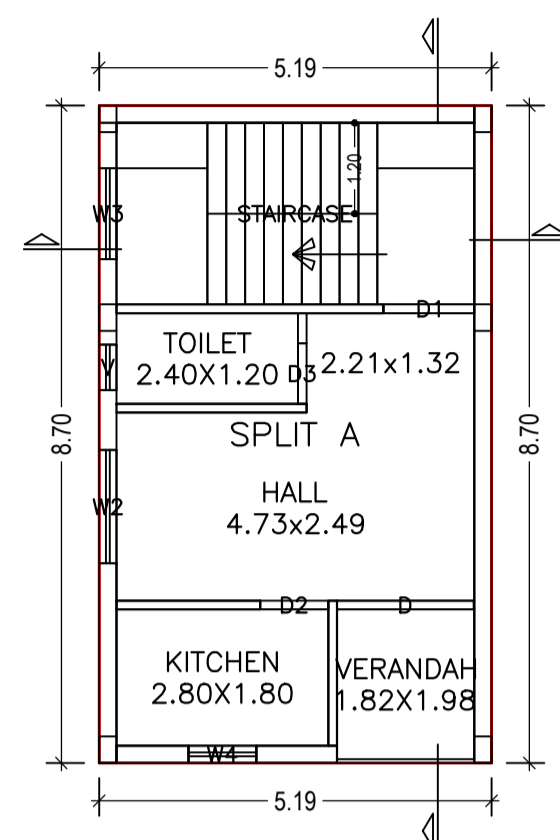

FIRST FLOOR PLAN
(Proposed)
(SCALE 1:100)

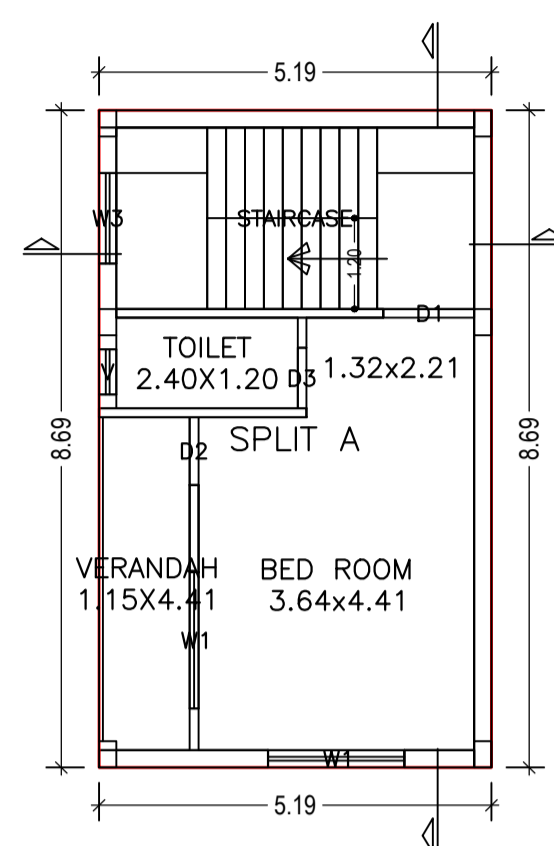

SECOND FLOOR PLAN
(Proposed)
(SCALE 1:100)

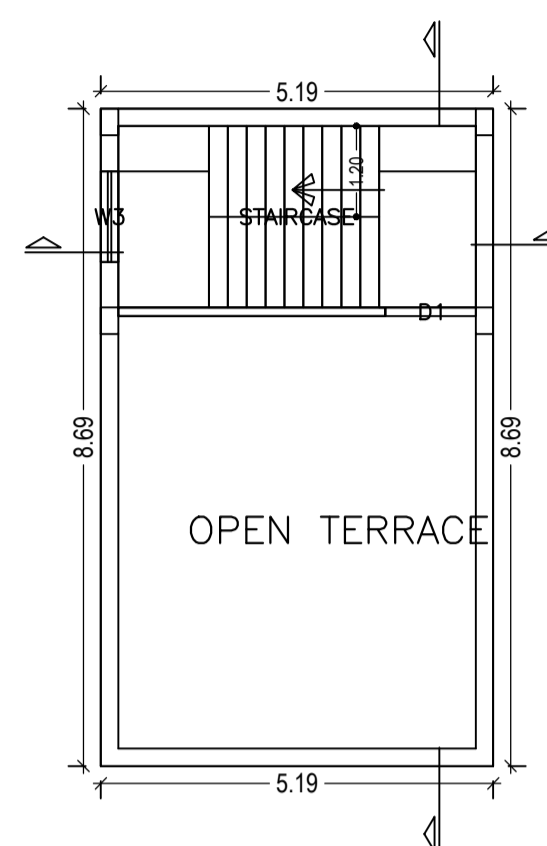

TERRACE FLOOR PLAN
(SCALE 1:100)

LTP NAME AND SIGNATURE	STRUCTURAL ENG'S NAME AND SIGNATURE	BUILDER NAME AND SIGNATURE	DIGITAL SIGNATURE
Shreyashi Halder JNAC/DFTMN/0009/2016			

Proposal Basic Information	
Proposal File No.	JNAC/BP/0117/W2/2019
Owner Name	SRI MANIK CHANDRA DAS AND RUP CHANDRA DAS
Khata No	NIL
Plot No	1382-E
Village Name	SONARI
Use	Residential
SubUse	Semidetached

Building :A (MANIK CHAND DAS)

Floor Name	Total Built Up Area (Sq.mt.)	Deductions (Area in Sq.mt.)		Proposed FAR Area (Sq.mt.)		Add Area In FAR (Sq.mt.)		Total FAR Area (Sq.mt.)	Total Consumed Additional FAR Area (Sq.mt.)	Tnmt (No.)
		Parking	Resi.	Stair	Stair					
Parking Floor	45.13	33.78	0.00	11.35	11.35	11.35	0.00	11.35	0.00	00
First Floor	45.13	0.00	45.13	0.00	45.13	45.13	0.00	45.13	45.13	01
Second Floor	45.13	0.00	45.13	0.00	45.13	45.13	0.00	45.13	45.13	00
Terrace Floor	0.00	0.00	0.00	0.00	0.00	0.00	0.00	0.00	0.00	00
Total :	135.39	33.78	90.26	11.35	101.61	101.61	0.00	101.61	101.61	01
Total Number of Same Buildings :	1									
Total :	135.39	33.78	90.26	11.35	101.61	101.61	0.00	101.61	101.61	01

UnitBUA Table for Building :A (MANIK CHAND DAS)

FLOOR	Name	UnitBUA Type	UnitBUA Area	Carpet Area	No. of Rooms	No. of Tenement
FIRST FLOOR PLAN	SPLIT A	FLAT	90.25	80.19	4	1
SECOND FLOOR PLAN	SPLIT A	FLAT	0.00	0.00	3	0
Total:	-	-	90.25	80.19	7	1

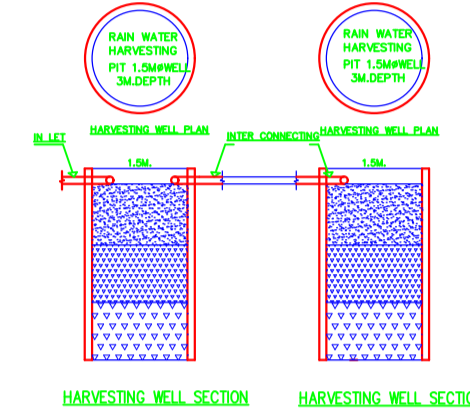

SCHEDULE OF DOOR:

BUILDING NAME	NAME	LENGTH	HEIGHT	NOS
A (MANIK CHAND DAS)	D3	0.80	2.10	02
A (MANIK CHAND DAS)	D2	0.90	2.10	02
A (MANIK CHAND DAS)	D1	1.20	2.10	02
A (MANIK CHAND DAS)	D	1.81	2.10	01

SCHEDULE OF WINDOW/VENTILATION:

BUILDING NAME	NAME	LENGTH	HEIGHT	NOS
A (MANIK CHAND DAS)	V	0.60	0.60	02
A (MANIK CHAND DAS)	W4	0.90	1.20	01
A (MANIK CHAND DAS)	W3	1.20	1.20	04
A (MANIK CHAND DAS)	W2	1.50	1.20	01
A (MANIK CHAND DAS)	W1	1.80	1.20	02

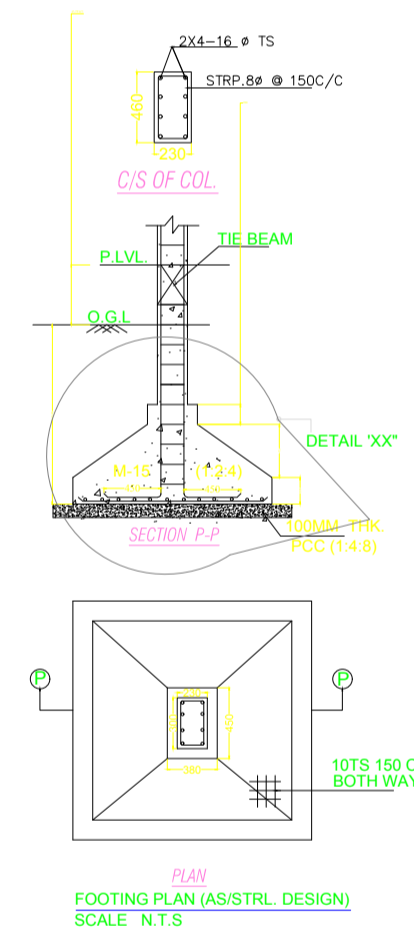

LTP NAME AND SIGNATURE	STRUCTURAL ENG'S NAME AND SIGNATURE	BUILDER NAME AND SIGNATURE	DIGITAL SIGNATURE
Shreyashi Haldar JNAC/DFTMN/0009/2016			

Proposal Basic Information

Proposal File No.	JNAC/BP/0117/W2/2019
Owner Name	SRI MANIK CHANDRA DAS AND RUP CHANDRA DAS
Khata No	NIL
Plot No	1382-E
Village Name	SONARI
Use	Residential
SubUse	Semidetached

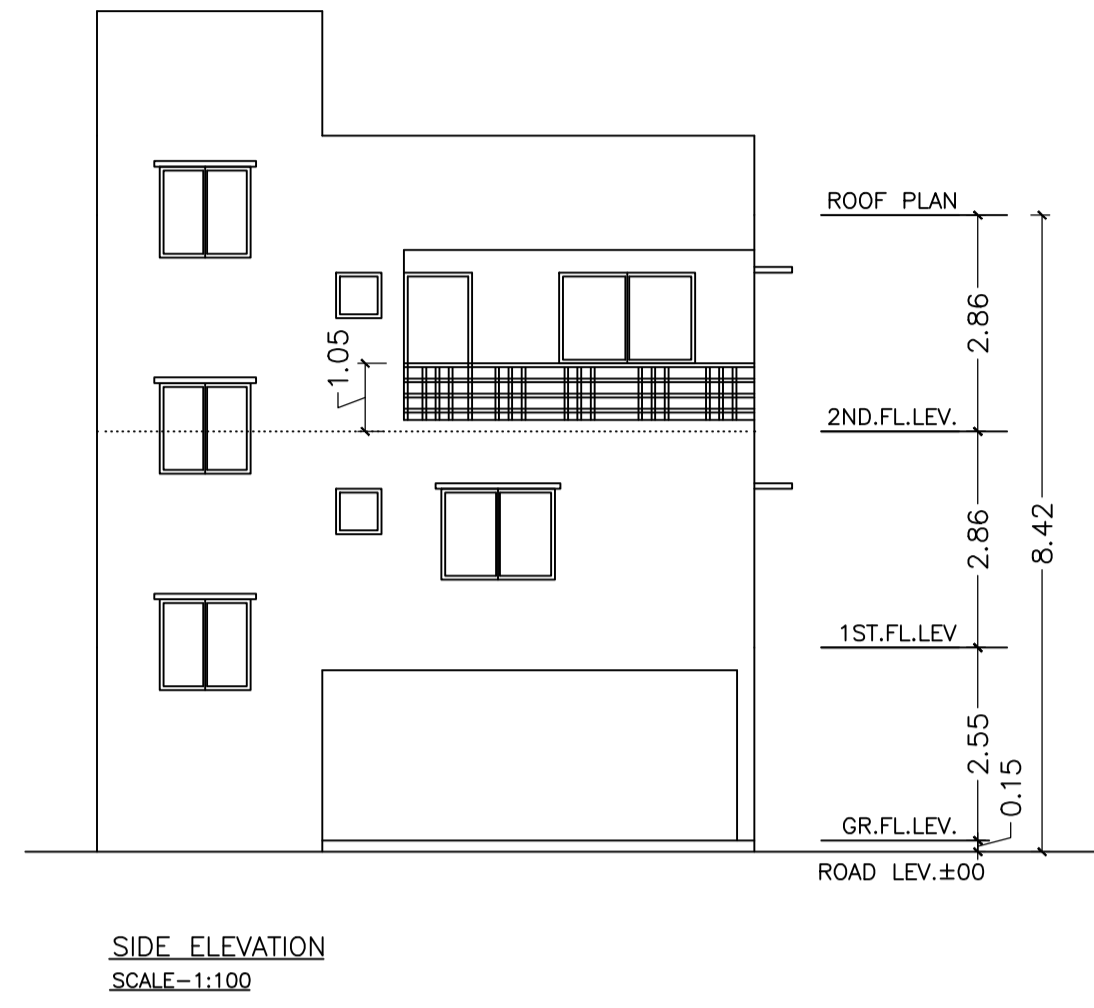
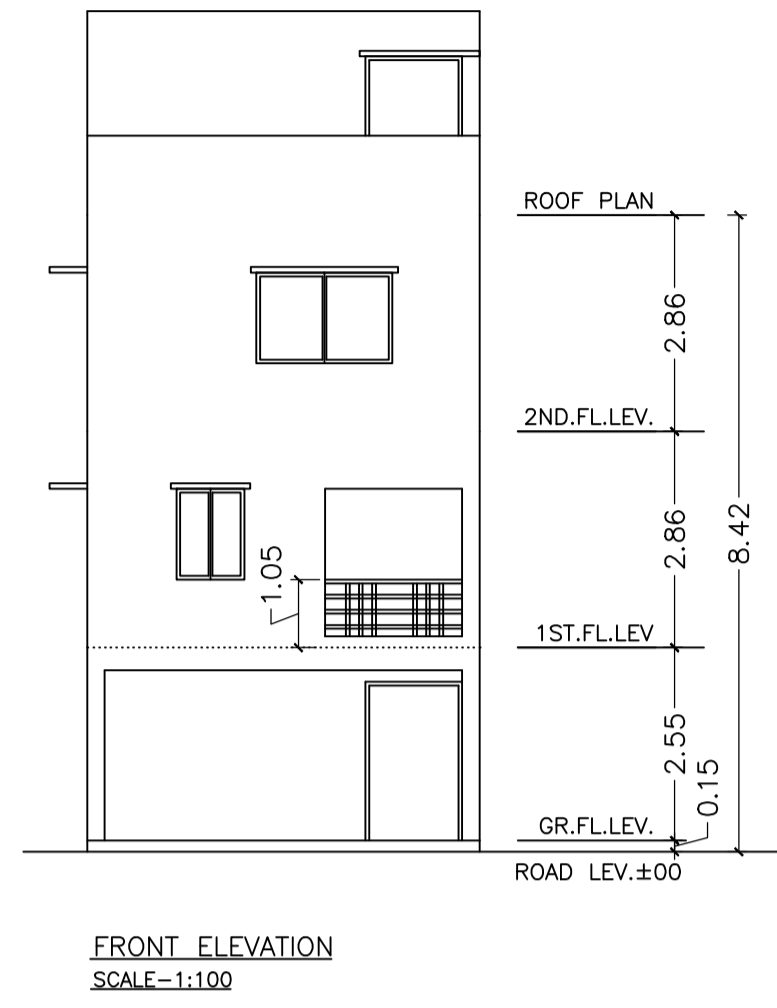
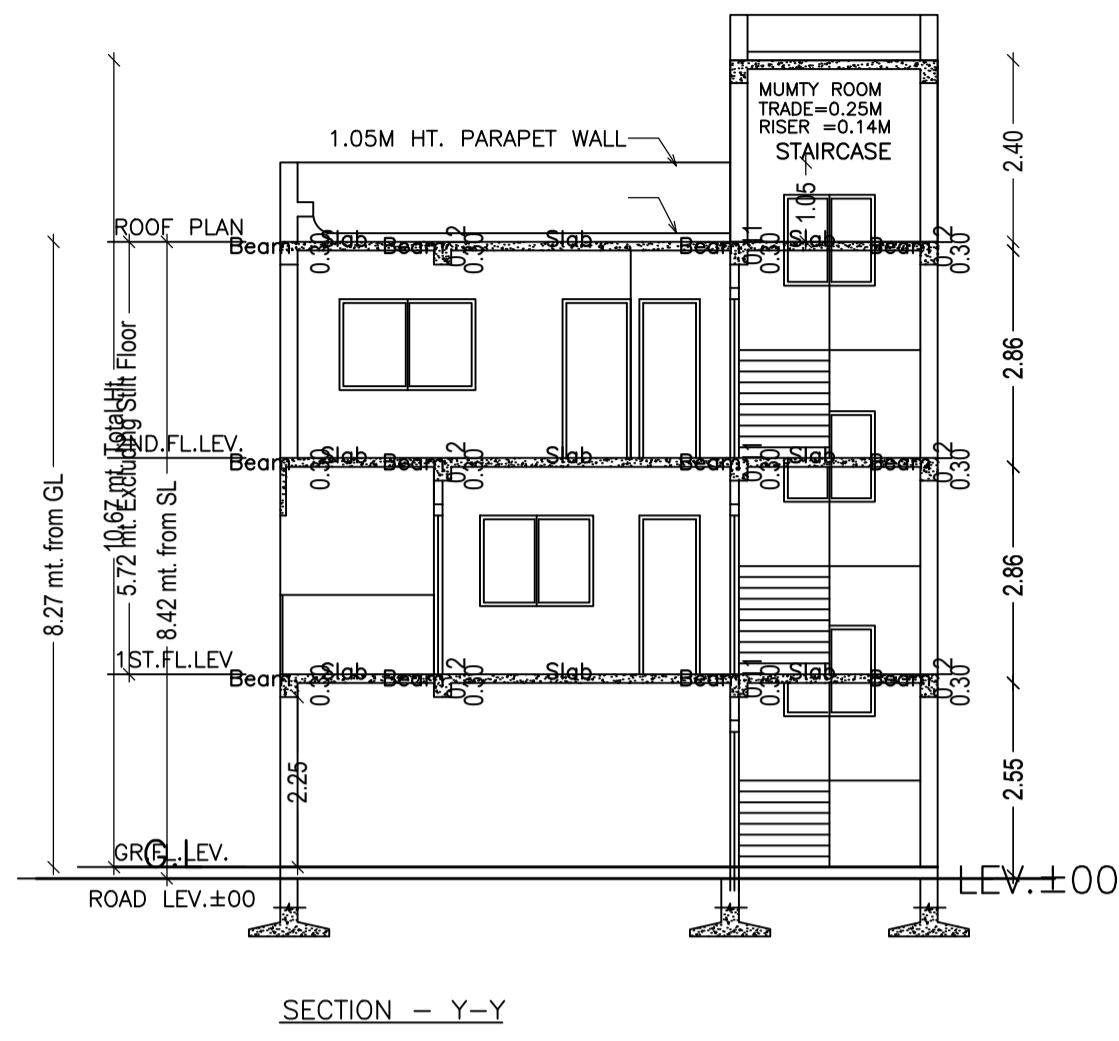

LTP NAME AND SIGNATURE	STRUCTURAL ENG'S NAME AND SIGNATURE	BUILDER NAME AND SIGNATURE	DIGITAL SIGNATURE
Shreyashi Halder JNAC/DFTMN/0009/2016			

Proposal Basic Information	
Proposal File No.	JNAC/BP/0117/W2/2019
Owner Name	SRI MANIK CHANDRA DAS AND RUP CHANDRA DAS
Khata No	NIL
Plot No	1382-E
Village Name	SONARI
Use	Residential
SubUse	Semidetached

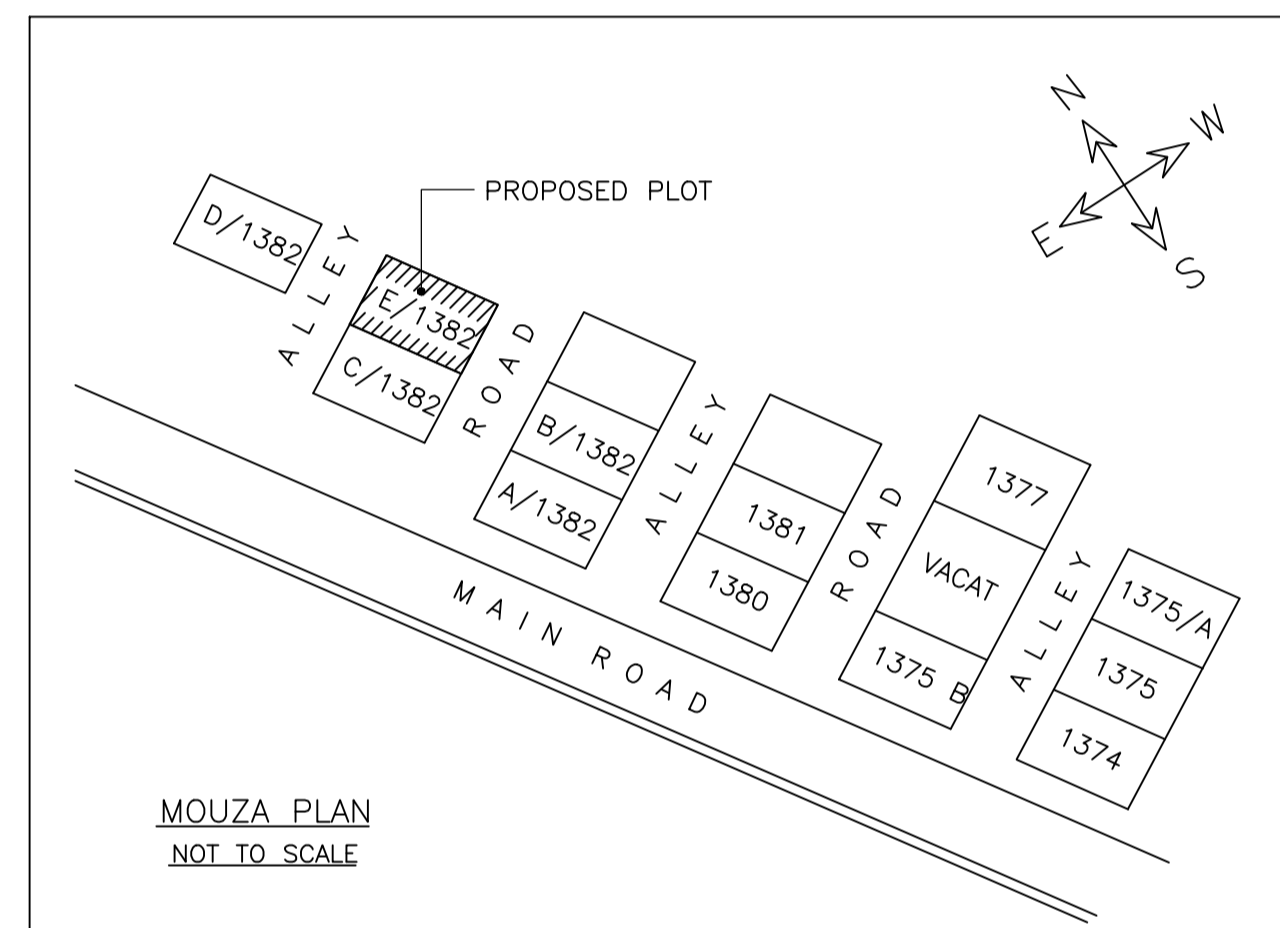
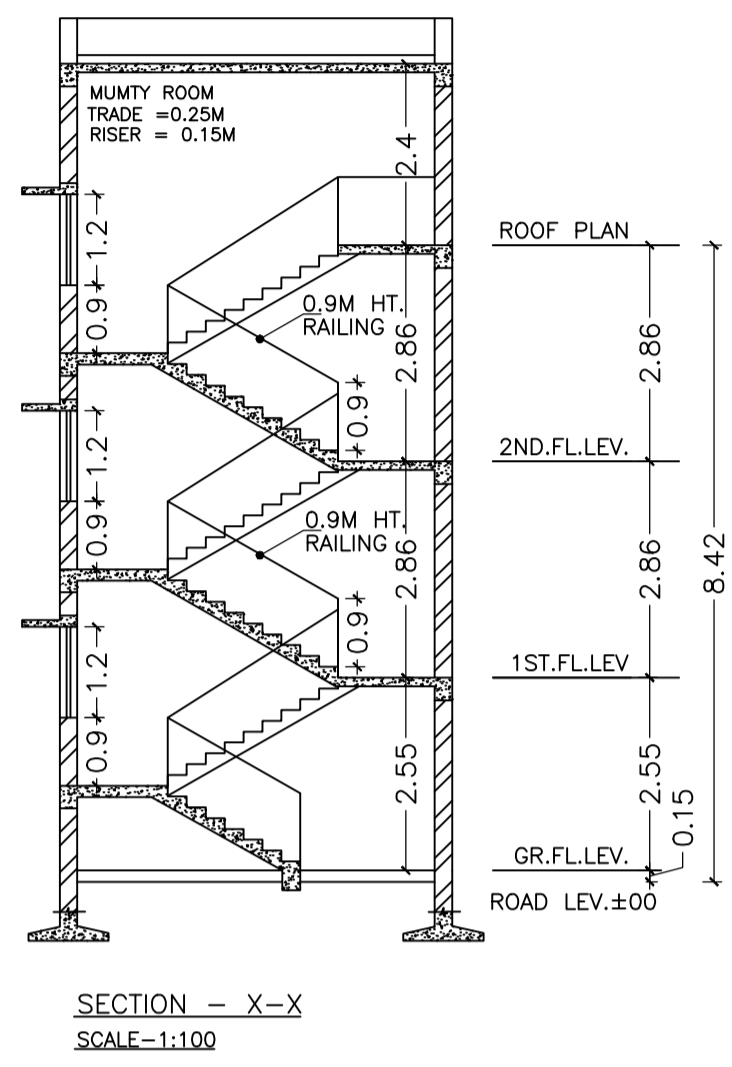

LTP NAME AND SIGNATURE	STRUCTURAL ENG'S NAME AND SIGNATURE	BUILDER NAME AND SIGNATURE	DIGITAL SIGNATURE
Shreyashi Halder JNAC/DFTMN/0009/2016			