

Project Title: (NIRUPA DEVI AGARWAL AND NEHA GUPTA)

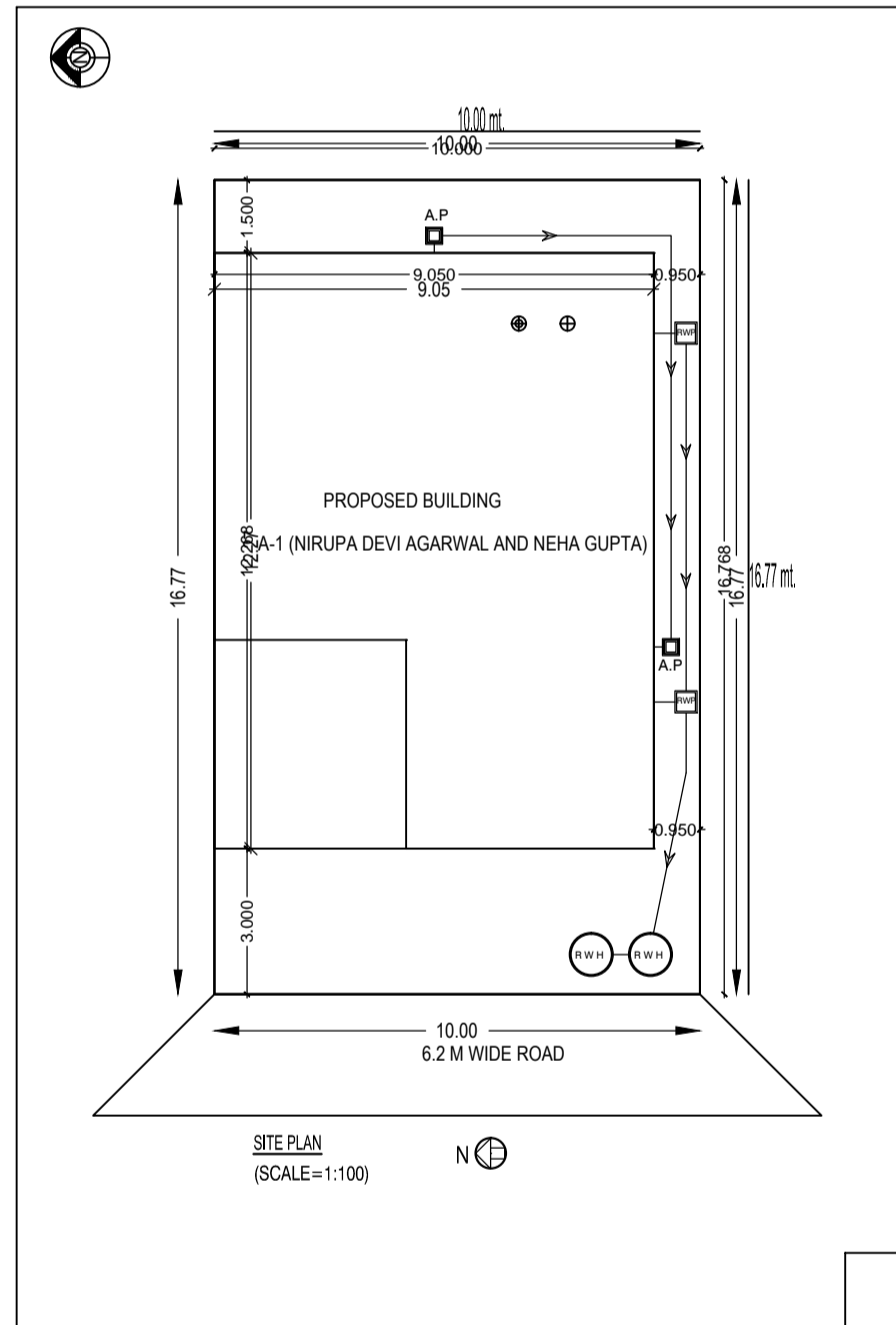
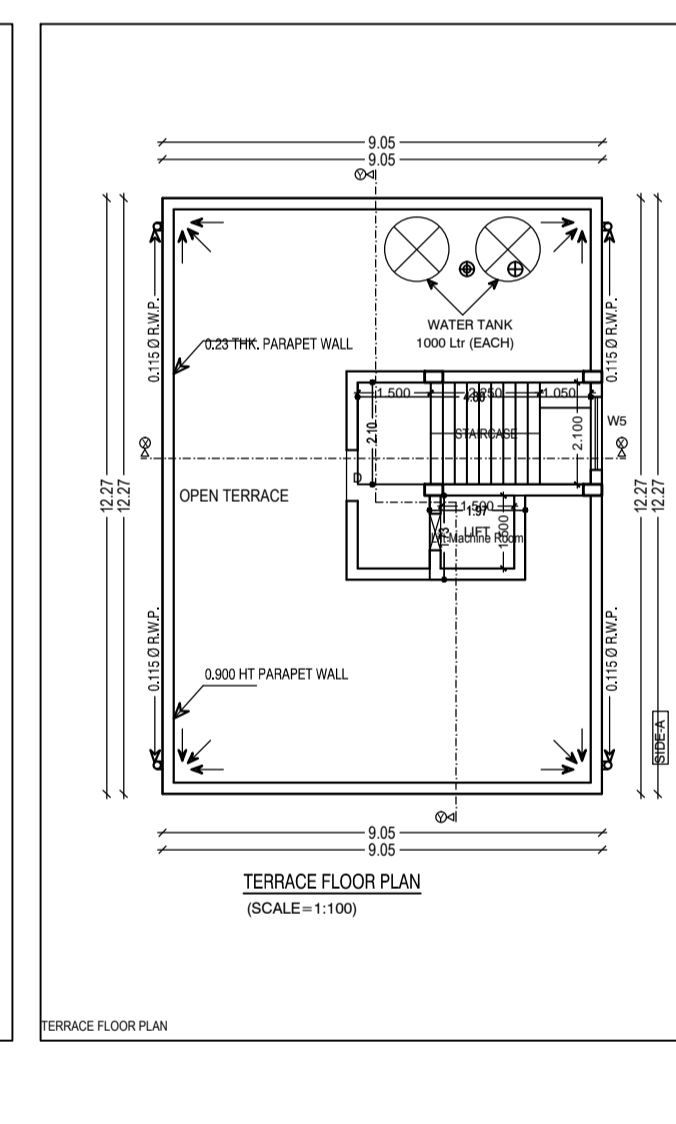
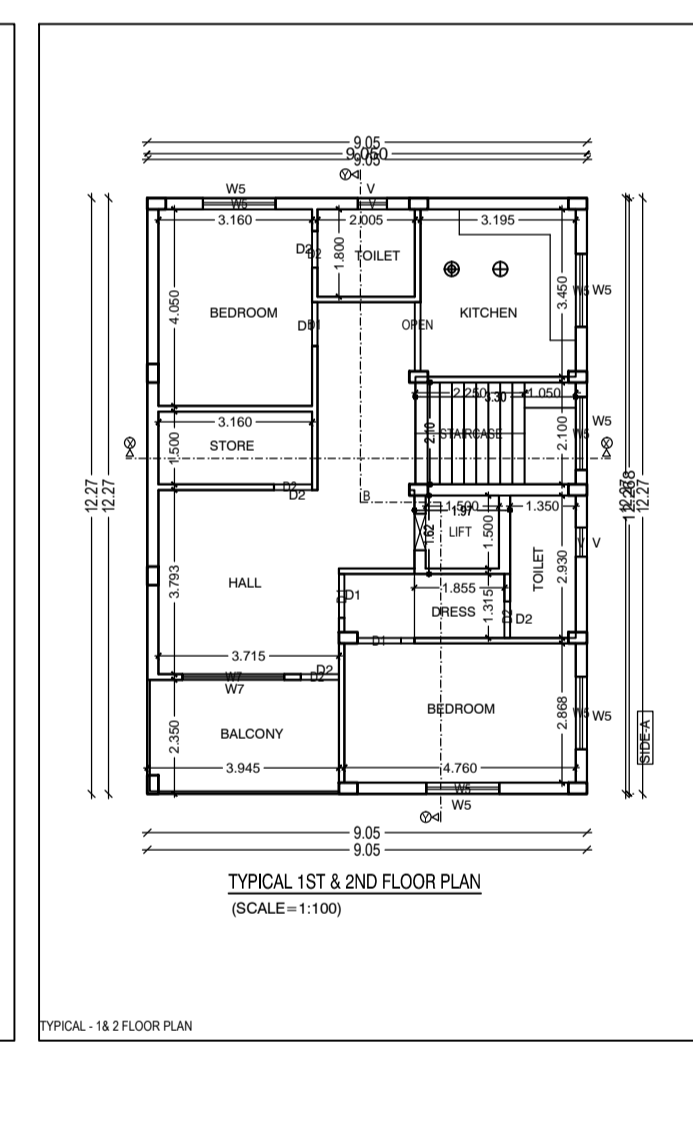
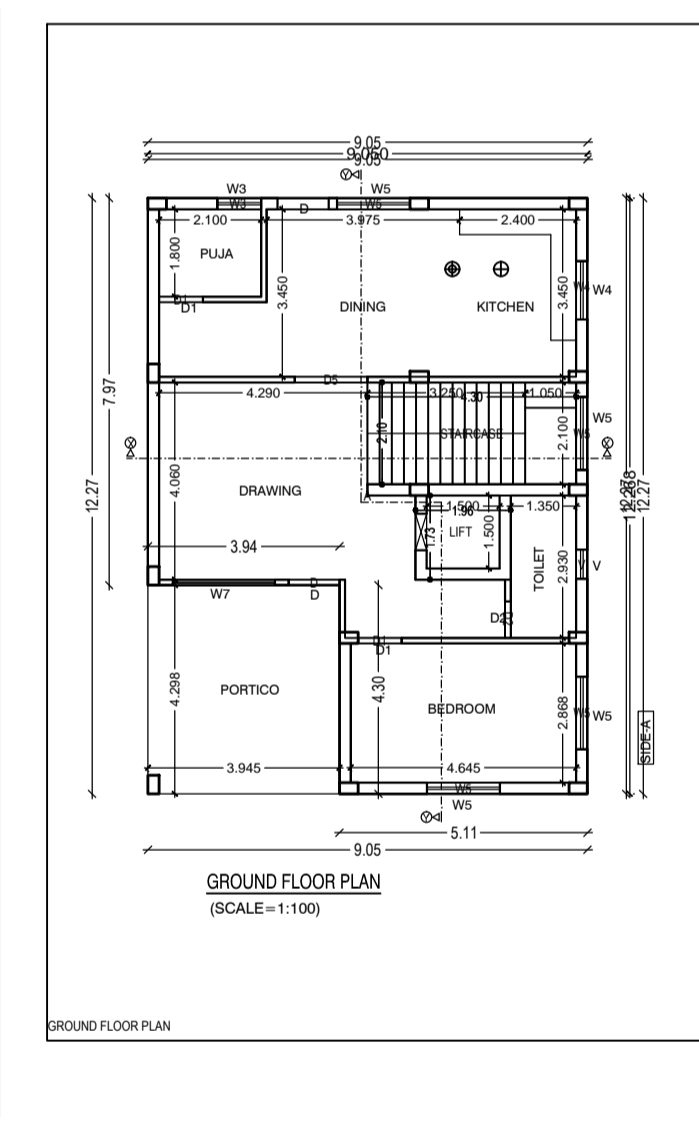
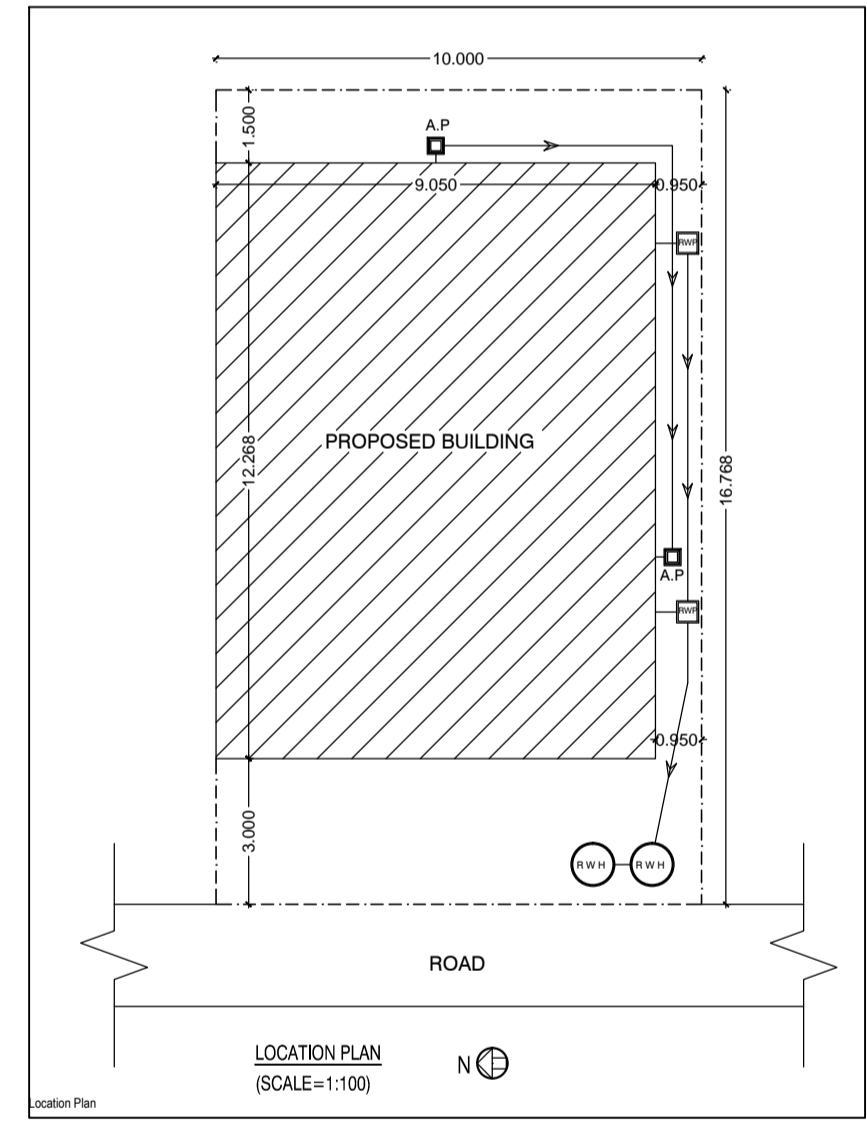
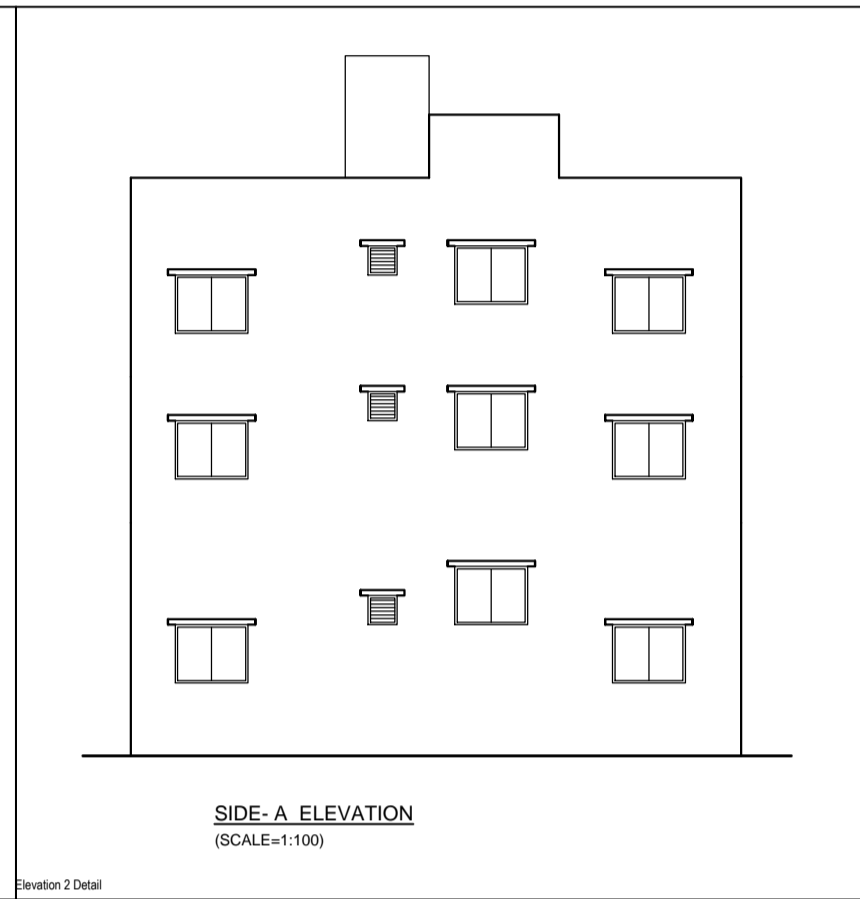
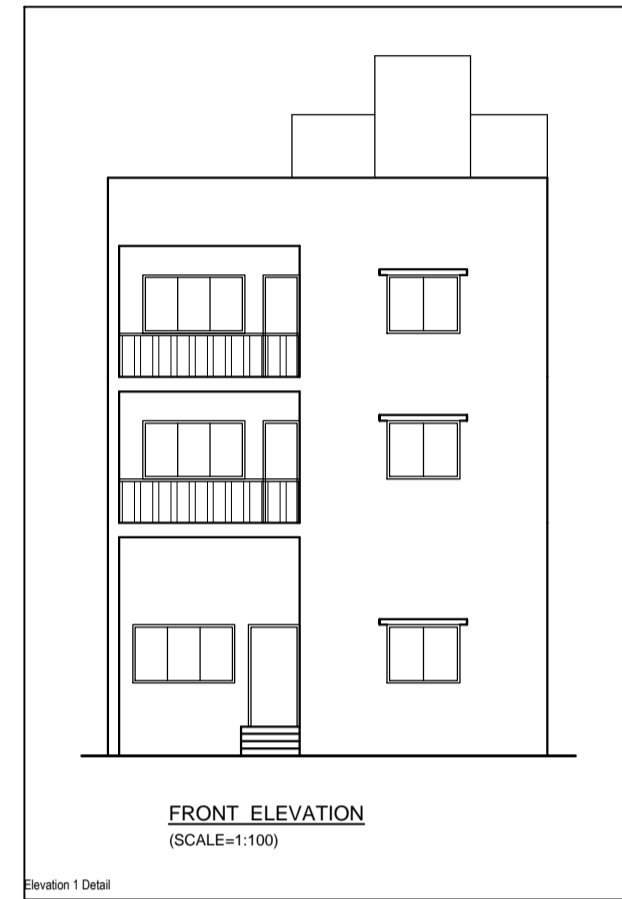
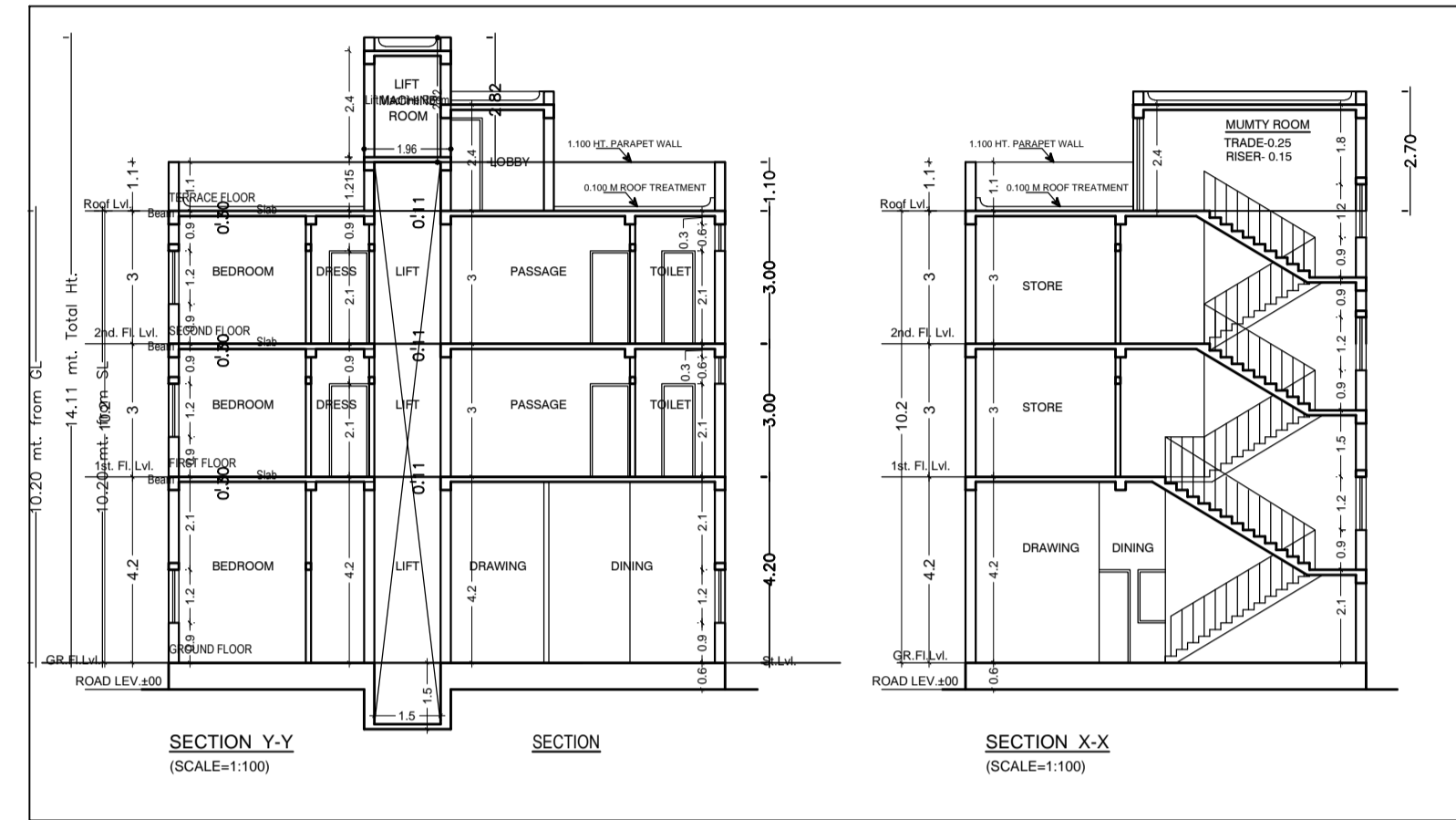
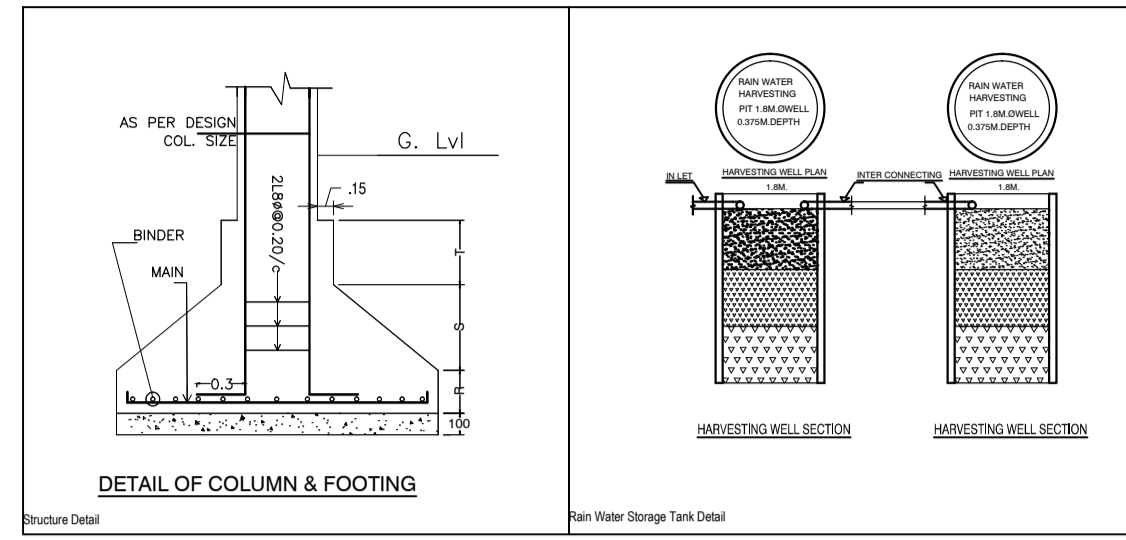

NOTE:
1. FOUNDATION & R.C.C. AS PER STRUCTURAL ENGR. SPECIFICATION
2. ALL DIMENSIONS IN Mtrs.
3. DRAWING NOT TO BE SCALED

OFFICE USE

AREA DETAILS	UNIT	SQ.MT
AREA OF PLOT (Minimum)	(A)	167.68
Nett Area (Total Plot Area - Deduction from Gross Plot area)	(A-Deductions)	167.68
Building Plot Area (Nett Plot Area - Recreational/Amenity space)	(A-Deductions)	167.68
Plot Area for Coverage (Nett Plot Area - Road/Widening Zone)	(A-Deductions)	167.68
Plot Area for FSI (Nett Plot Area - Road/Widening Zone)	(A-Deductions)	167.68

COVERAGE CHECK

Proposed Coverage Area (62.15%)	141.57
Total Coverage Area (62.15%)	141.57

FAR CHECK

Proposed Area of FAR	306.36
Total Area of FAR	306.36

BUILT UP AREA CHECK:

Total Proposed Builtup Area	312.72
ARCHITECT/SUPERVISOR (Sign)	OWNER

DEVELOPMENT AUTHORITY

LOCAL BODY

COLOR INDEX

Color Index	Color
PLLOT BOUNDARY	Black
ABUTTING ROAD	Red
PROPOSED WORK (COVERAGE AREA)	Green
EXISTING (To be retained)	Blue
EXISTING (To be demolished)	Yellow

MARGIN DETAIL:

Road Name	Front Margin	Rear Margin	Side Margin	Stk'd Margin
A.T. NIRUPA DEVI AGARWAL AND NEHA GUPTA	3.00	1.50	0.00	0.95

FAR & Tenement Details (Table 4e-1)

Building	No. of Same Bldg	Total Built Up Area (Sq.mt)	Deductions (Area in Sq.mt)	Proposed FAR Area (Sq.mt)	Total FAR Area (Sq.mt)	Tenent (No.)
A. NIRUPA DEVI AGARWAL AND NEHA GUPTA	1	312.72	6.36	306.36	306.36	03
Grand Total	1	312.72	6.36	306.36	306.36	03

APPROVED:-
SPL OFFICER, J.N.A.C.
OWNER / POAH

Signature of Applicant:-
GENERAL SPECIFICATION :-
FOUNDATION : PLAIN CEMENT CONCRETE AS PER DESIGN.
R.C.C. COLUMN FOOTING & COLUMN AS PER STRUCTURAL DESIGN.
SUPER STRUCTURE : R.C.C. COLUMN & BEAM AS PER STR. DESIGN.
0.15M THK. EXT. WALL & 0.15M THK. PARTITION WALL IN CEMENT MORTAR.
R.C.C. ROOF SLAB AS PER STRUCTURAL DESIGN.
FLOOR : MOSAIC CAST IN SITU CERAMIC TILES DADED IN TOILET.
INTERNAL FINISH : CEMENT PLASTER WITH P.O.P. & O.B.D.
SHEATHING : VITRULOUS CHINA CLAY SANITARY WARE G.I.
PIPE WATER SUPPLY : P.V.C. PIPE FOR SEWAGE DISPOSAL.
DOORS & WINDOW : AS PER SCHEDULE.
ELECTRICAL : COPPER WIRE WITH P.V.C. CONDUIT.

PROPOSED RESIDENTIAL BUILDING PLAN OF 1. MRS. NIRUPA DEVI AGARWAL W/O MR. BIKASH AGARWAL, & 2. MRS. NEHA GUPTA W/O MR. BIVEK GUPTA R.S. PLOT NO- 546 (OLD), 78(NEW) KHATA NO- 22 (OLD), 188 (NEW) MOUZA - SONARI, SURVEY WARD NO.- 01, JNAC, P.S.- SONARI, THANA NO.-1156, DISTRICT-EAST SINGHBHUM, JHARKHAND TOWN-JAMSHEDPUR

L.K. SUMAN
Reg No- C-20/2022
M-9653131161

Building 'A' (NIRUPA DEVI AGARWAL AND NEHA GUPTA)

Floor Name	Total Built Up Area (Sq.mt)	Deductions (Area in Sq.mt)	Proposed FAR Area (Sq.mt)	Total FAR Area (Sq.mt)	Tenent (No.)
Ground Floor	90.88	0.00	90.88	90.88	01
First Floor	111.02	2.18	107.84	107.84	01
Second Floor	0.00	0.00	0.00	0.00	00
Terrace	306.36	0.00	306.36	306.36	03
Total	312.72	6.36	306.36	306.36	03

SCHEDULE OF JOINERY:

BUILDING NAME	NAME	LENGTH	HEIGHT	NOS
A. NIRUPA DEVI AGARWAL AND NEHA GUPTA	V	0.75	2.10	06
A. NIRUPA DEVI AGARWAL AND NEHA GUPTA	D2	0.79	2.10	04
A. NIRUPA DEVI AGARWAL AND NEHA GUPTA	D1	0.90	2.10	06
A. NIRUPA DEVI AGARWAL AND NEHA GUPTA	D	1.05	2.10	01
A. NIRUPA DEVI AGARWAL AND NEHA GUPTA	OPEN	1.42	2.10	02
A. NIRUPA DEVI AGARWAL AND NEHA GUPTA	D5	1.50	2.10	01
Total				21

SCHEDULE OF JOINERY:

BUILDING NAME	NAME	LENGTH	HEIGHT	NOS
A. NIRUPA DEVI AGARWAL AND NEHA GUPTA	V	0.60	1.00	06
A. NIRUPA DEVI AGARWAL AND NEHA GUPTA	W3	0.90	1.20	01
A. NIRUPA DEVI AGARWAL AND NEHA GUPTA	W4	1.20	1.20	01
A. NIRUPA DEVI AGARWAL AND NEHA GUPTA	W5	1.50	1.20	14
A. NIRUPA DEVI AGARWAL AND NEHA GUPTA	W7	2.10	1.20	02
Total				23

UnitBUA Table for Building 'A' (NIRUPA DEVI AGARWAL AND NEHA GUPTA)

FLOOR	Name	UnitBUA Type	UnitBUA Area	Carpet Area	No. of Rooms	No. of Tenement
GROUND FLOOR PLAN	A	FLAT	90.88	81.06	7	1
TYPICAL 1st & 2nd FLOOR PLAN	B	FLAT	107.84	97.56	11	2