

Sl. No.	Particulars	Quantity	Unit	Rate	Amount
1	Area of Plot	100	Sq. Mtr.	100	10000
2	Area of Building	100	Sq. Mtr.	100	10000
3	Area of Road	100	Sq. Mtr.	100	10000
4	Area of Open Space	100	Sq. Mtr.	100	10000
5	Area of Water Body	100	Sq. Mtr.	100	10000
6	Area of Other	100	Sq. Mtr.	100	10000
7	Area of Total	100	Sq. Mtr.	100	10000

Building A (SRI ANIL KUMAR HALDAR, SRI SUSHIL KUMAR HALDAR, SRI BIJAY KUMAR HALDAR, SRI ASHOK KUMAR HALDAR, SRI AJIT KUMAR HALDAR, SMT SAMITA HALDAR AND OTHERS)

Particulars	Area (Sq. Mtr.)	Volume (Cu. Mtr.)	Weight (Kilograms)
Concrete	100	100	10000
Brick	100	100	10000
Steel	100	100	10000
Other	100	100	10000
Total	100	100	10000

Sl. No.	Particulars	Area (Sq. Mtr.)	Volume (Cu. Mtr.)	Weight (Kilograms)
1	Concrete	100	100	10000
2	Brick	100	100	10000
3	Steel	100	100	10000
4	Other	100	100	10000
Total	100	100	10000	

Sl. No.	Particulars	Area (Sq. Mtr.)	Volume (Cu. Mtr.)	Weight (Kilograms)
1	Concrete	100	100	10000
2	Brick	100	100	10000
3	Steel	100	100	10000
4	Other	100	100	10000
Total	100	100	10000	

UNBIA Table for Building A (SRI ANIL KUMAR HALDAR, SRI SUSHIL KUMAR HALDAR, SRI BIJAY KUMAR HALDAR, SRI ASHOK KUMAR HALDAR, SRI AJIT KUMAR HALDAR, SMT SAMITA HALDAR AND OTHERS)

Sl. No.	Particulars	Area (Sq. Mtr.)	Volume (Cu. Mtr.)	Weight (Kilograms)
1	Concrete	100	100	10000
2	Brick	100	100	10000
3	Steel	100	100	10000
4	Other	100	100	10000
Total	100	100	10000	

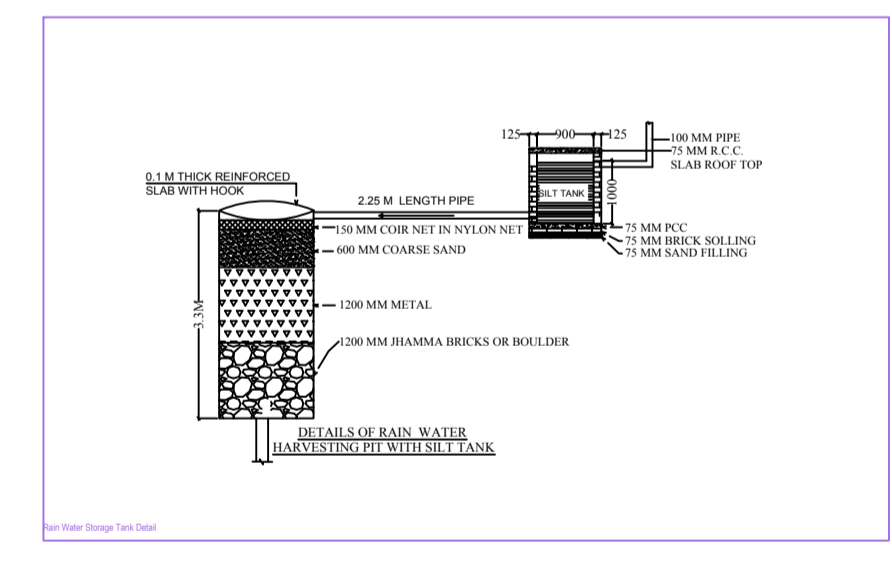
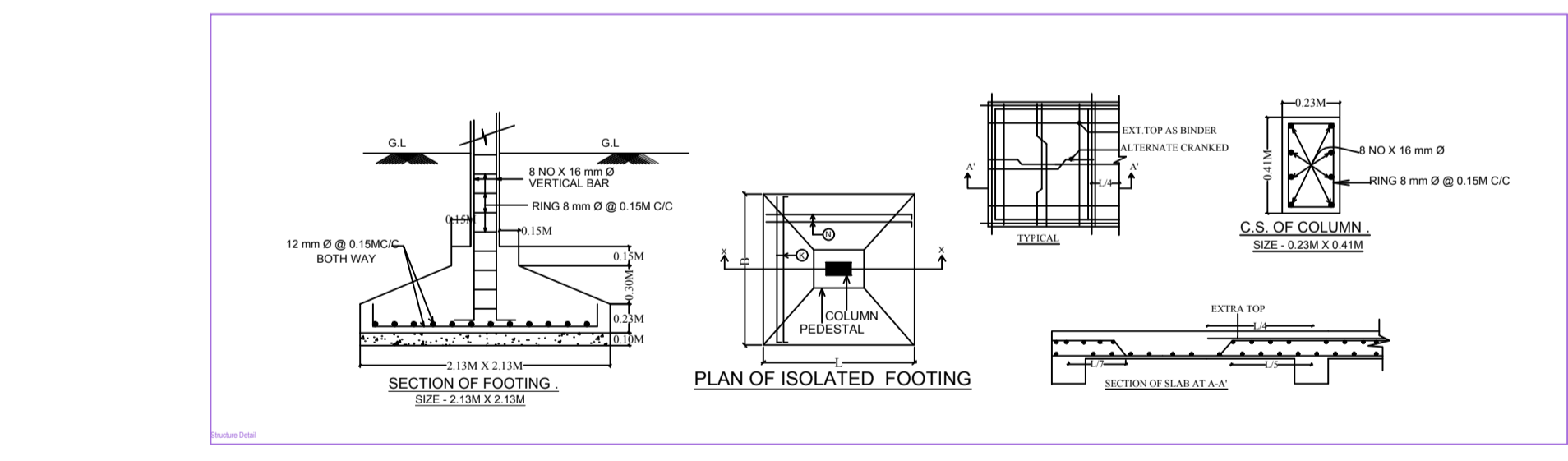
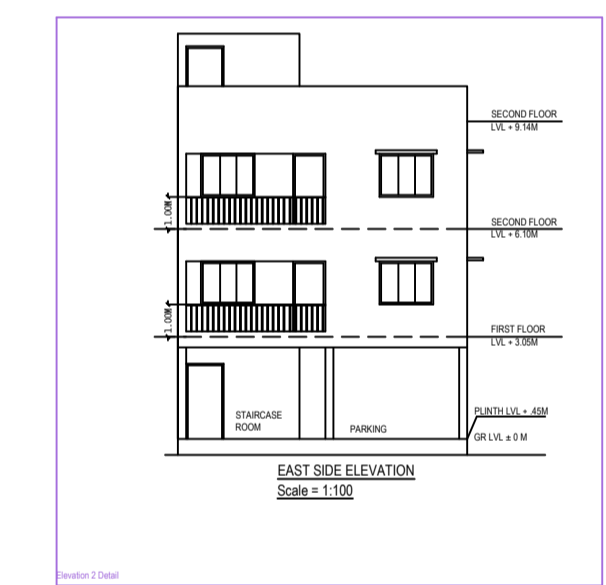
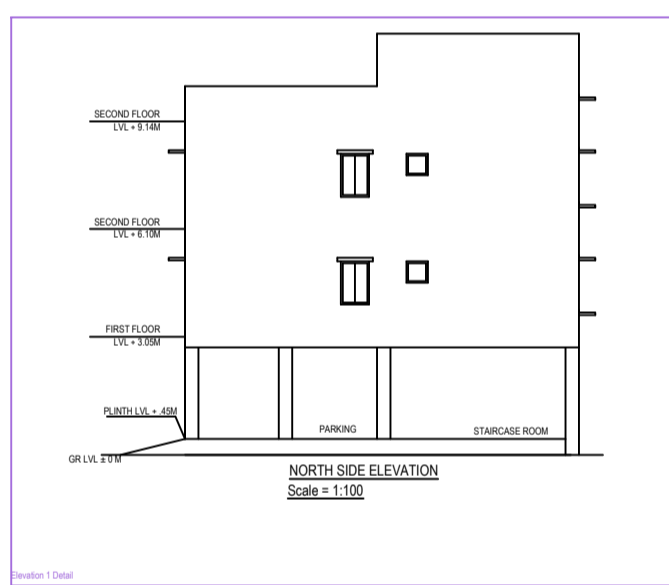
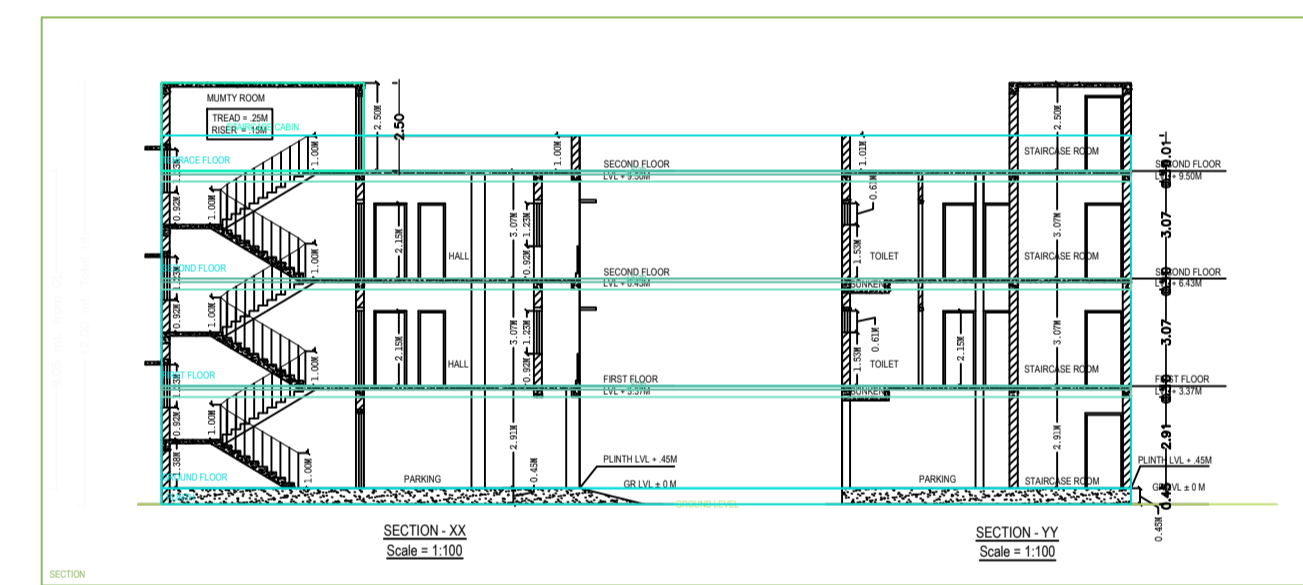

NOTE:- ALL DIMENSION ARE IN METER
PROPOSED RESIDENCE OF SRI ANIL KUMAR HALDAR, SRI SUSHIL KUMAR HALDAR, SRI BIJAY KUMAR HALDAR, SRI ASHOK KUMAR HALDAR, SRI AJIT KUMAR HALDAR, SMT SAMITA HALDAR AND OTHERS
HOLDING NO. 86, WARD NO. 1, THANA NO. - 1156
MOUZA - SONARI, DIST. - EAST SINGHBHUM, STATE - JHARKHAND

OWNER
SRI ANIL KUMAR HALDAR, SRI SUSHIL KUMAR HALDAR, SRI BIJAY KUMAR HALDAR, SRI ASHOK KUMAR HALDAR, SRI AJIT KUMAR HALDAR, SMT SAMITA HALDAR AND OTHERS

SPECIAL OFFICER

ARCHITECT

CHEK BY
DRG. NO. 01
DATE
SCALE 1:100

PROJECT CONSULTANT
Lawrence & Kunj Associates
17/2, 2nd Floor, West Layout, Jamshedpur-83

Sl. No.	Particulars	Area (Sq. Mtr.)	Volume (Cu. Mtr.)	Weight (Kilograms)
1	Concrete	100	100	10000
2	Brick	100	100	10000
3	Steel	100	100	10000
4	Other	100	100	10000
Total	100	100	10000	

Sl. No.	Particulars	Area (Sq. Mtr.)	Volume (Cu. Mtr.)	Weight (Kilograms)
1	Concrete	100	100	10000
2	Brick	100	100	10000
3	Steel	100	100	10000
4	Other	100	100	10000
Total	100	100	10000	

(SRI ANIL KUMAR HALDAR, SRI SUSHIL KUMAR HALDAR, SRI BIJAY KUMAR HALDAR, SRI ASHOK KUMAR HALDAR, SRI AJIT KUMAR HALDAR, SMT SAMITA HALDAR AND OTHERS)