

Proposal Basic Information	
Proposal File No.	JNAC/BP/0106/W11/2019
Owner Name	SRI MAHENDRA
Khata No	NIL
Plot No	272
Village Name	Sitaramdera
Use	Residential
SubUse	Semidetached

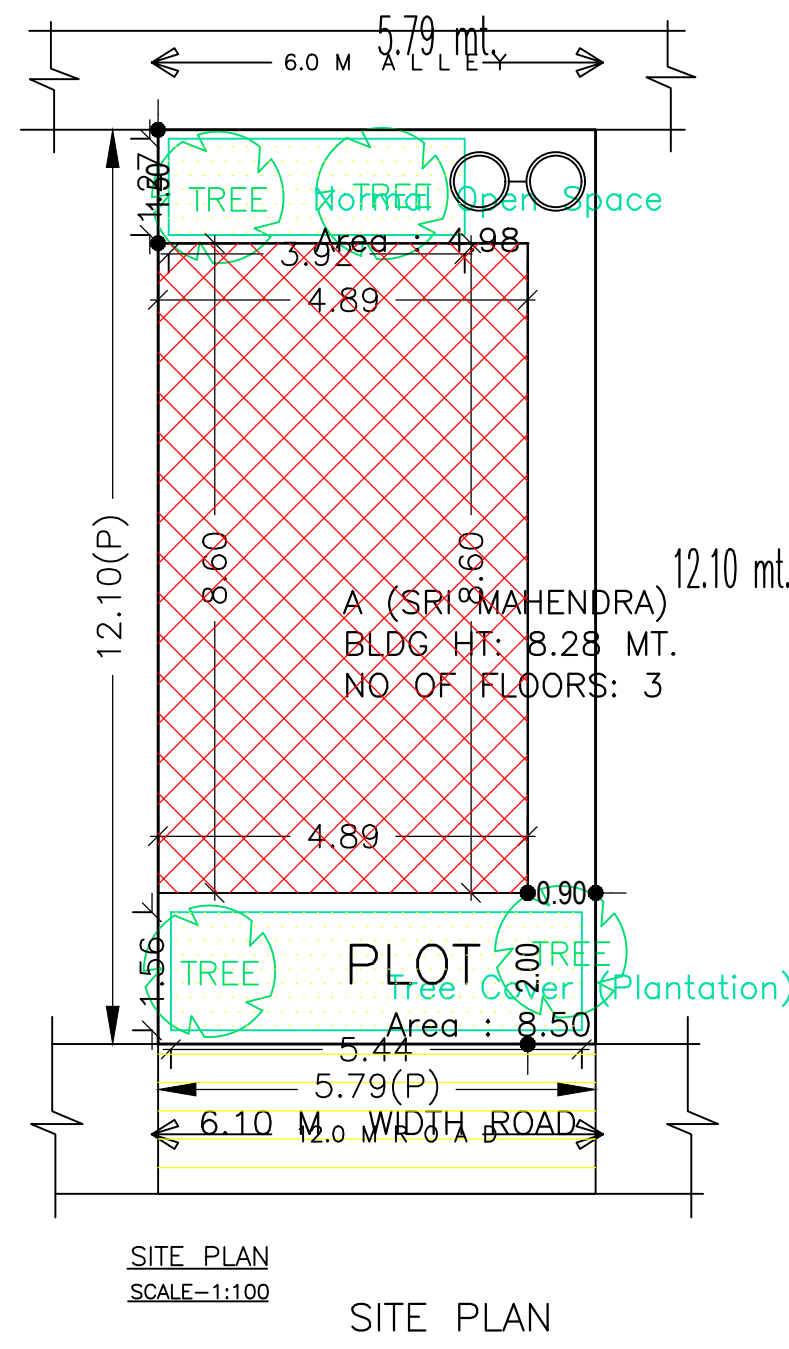

AREA STATEMENT		VERSION NO. : 1.0.43
JAMSHEDPUR NAC		VERSION DATE: 29/04/2019
PROJECT DETAIL:		
Region: JHARKHAND URBAN LOCAL BODIES	Plot Use: Residential	
District: EAST SINGHBHUM	Plot SubUse: Semidetached	
Authority: JAMSHEDPUR NAC	PlotNearbyReligiousStructure: NA	
Inward No. :JNAC/BP/0106/W11/2019		
Application Type: General Proposal	North: Plot No. - 273	
Project Type: Building Permission	South: Plot No. - 271	
Nature of Development: New	East: Road Width - 9.0	
Location of Development Area: Old Area	West: Road Width - 4.50	
AREA DETAILS:		
AREA OF PLOT (Minimum)	(A)	SQ.MT. 70.03
NET AREA OF PLOT(Gross Plot Area - Deduction from Gross Plot area)	(A-Deductions)	70.03
Deduction for Balance Plot Area(from Gross Plot Area)		
Common Plot		13.48
Total		13.48
BALANCE AREA OF PLOT(Net Plot Area - Recreational/Amenity space)	(A-Deductions)	56.55
PLOT AREA FOR COVERAGE(Net Plot Area)	(A-Deductions)	70.03
Plot Area for FAR (Net Plot Area + RoadWidening Area)	(A-Deductions)	70.03
COVERAGE CHECK		
Permissible Coverage area (70.00 %)		49.02
Proposed Coverage Area (60.02 %)		42.03
Total Prop. Coverage Area (60.02 %)		42.03
Balance coverage area (9.98 %)		6.99
FAR CHECK		
Perm. FAR Area (2.50)		175.07
Total Perm. FAR area		175.07
Residential FAR		84.06
Proposed FAR Area		93.19
Total Proposed FAR Area		93.19
Consumed FAR (Factor)		1.33
Balance FAR Area		81.88
BUILT UP AREA CHECK		
Total Proposed BuiltUp Area		126.09
ARCHITECT (Regd)	Ajit Kumar Dhar	
ENGINEER (Regd)		
SUPERVISOR (Regd)		
OWNER (Regd)	SRI MAHENDRA	
DEVELOPMENT AUTHORITY LOCAL BODY		

COLOR INDEX	
PLOT BOUNDARY	Black
ABUTTING ROAD	Red
PROPOSED CONSTRUCTION	Green
COMMON PLOT	Yellow
ROAD WIDENING AREA	Blue
EXISTING (To be retained)	Orange
EXISTING (To be demolished)	Grey

Buildingwise Floor FAR Details

Floor Name	Building Name A (SRI MAHENDRA)		Total	
	Proposed Built Up Area (Sq.mt.)	Proposed FAR Area (Sq.mt.)	Total Proposed Built Up Area (Sq.mt.)	Total FAR Area (Sq.mt.)
Parking Floor	42.03	9.14	42.03	9.14
First Floor	42.03	42.03	42.03	42.03
Second Floor	42.03	42.03	42.03	42.03
Terrace Floor	0.00	0.00	0.00	0.00
	126.09	93.20	126.09	93.20

Building USE/SUBUSE Details

Building Name	Building Use	Building SubUse	Building Structure
A (SRI MAHENDRA)	Residential	Row House	Non-Highrise

FAR & Tenement Details (Table 4c-1)

Building	No. of Same Bldg	Total Built Up Area (Sq.mt.)	Deductions (Area in Sq.mt.)		Proposed FAR Area (Sq.mt.)	Add Area In FAR (Sq.mt.)	Total FAR Area (Sq.mt.)	Total Consumed Additional FAR Area (Sq.mt.)	Tnmt (No.)
			Parking	Resi.					
A (SRI MAHENDRA)	1	126.09	32.89	84.06	9.14	93.20	93.20	01	
Grand Total :	1	126.09	32.89	84.06	9.14	93.20	93.20	01	

LTP NAME AND SIGNATURE	STRUCTURAL ENG'S NAME AND SIGNATURE	BUILDER NAME AND SIGNATURE	DIGITAL SIGNATURE
Ajit Kumar Dhar JNAC/DFTMN/0009/2017			

Proposal Basic Information

Proposal File No.	JNAC/BP/0106/W11/2019
Owner Name	SRI MAHENDRA
Khata No	NIL
Plot No	272
Village Name	Sitaramdera
Use	Residential
SubUse	Semidetached

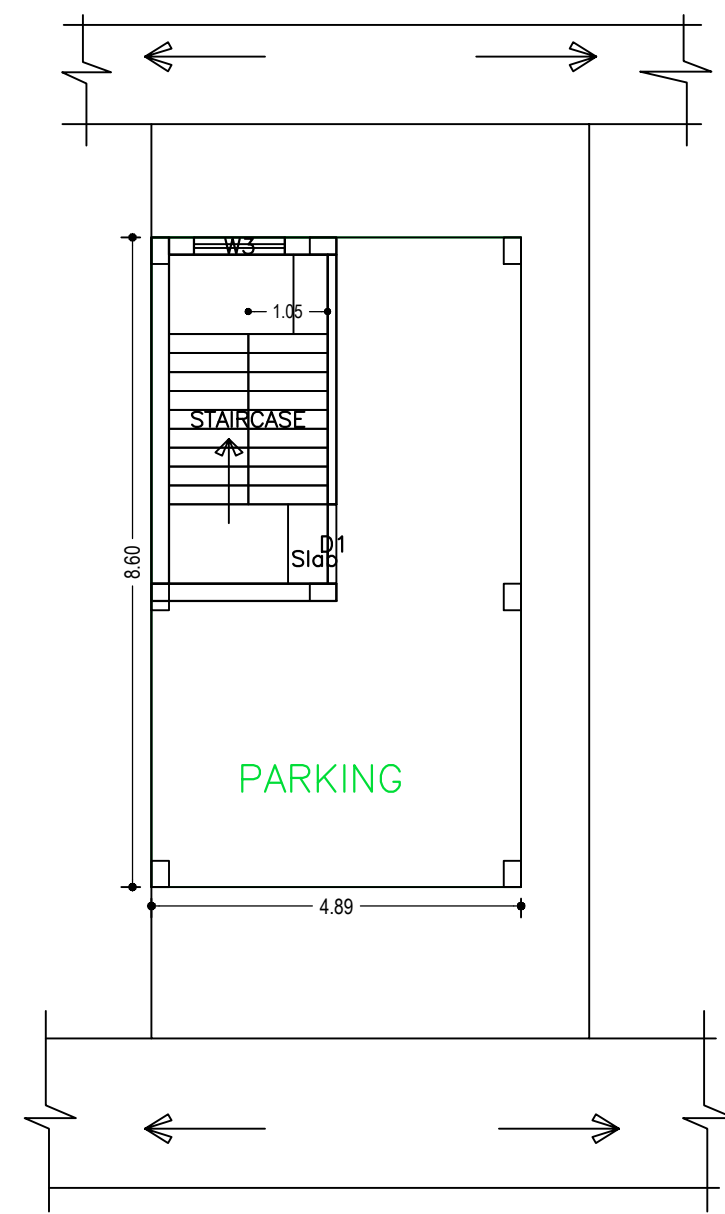

PARKING FLOOR PLAN
(SCALE 1:100)

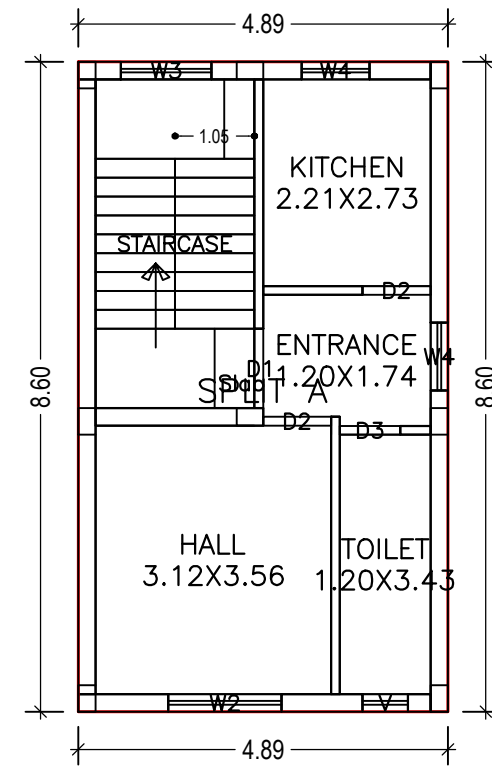

FIRST FLOOR PLAN
(Proposed)
(SCALE 1:100)

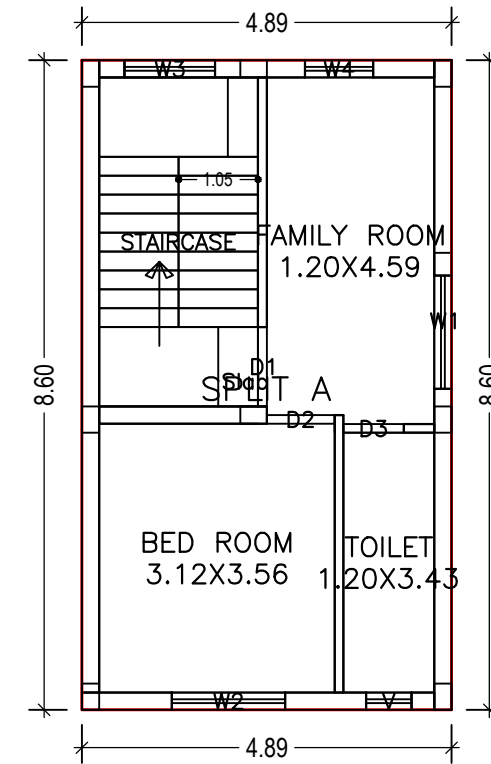

SECOND FLOOR PLAN
(Proposed)
(SCALE 1:100)

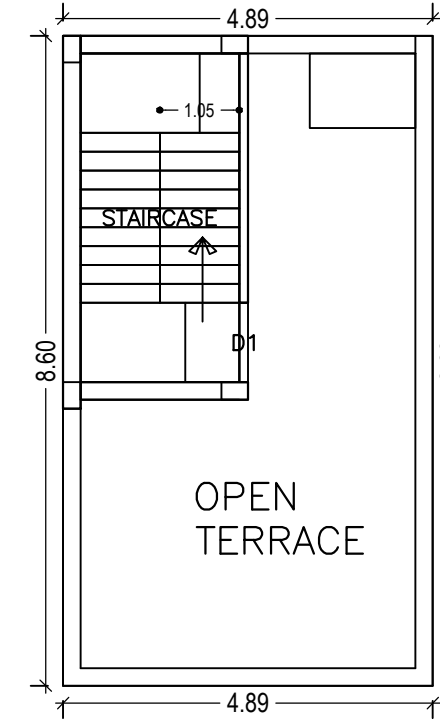

TERRACE FLOOR PLAN
(SCALE 1:100)

Building :A (SRI MAHENDRA)

Floor Name	Total Built Up Area (Sq.mt.)	Deductions (Area in Sq.mt.)		Proposed FAR Area (Sq.mt.)	Add Area In FAR (Sq.mt.)	Total FAR Area (Sq.mt.)	Total Consumed Additional FAR Area (Sq.mt.)	Tnmt (No.)
		Parking	Resi.					
Parking Floor	42.03	32.89	0.00	9.14	9.14	9.14	0.00	00
First Floor	42.03	0.00	42.03	0.00	42.03	42.03	42.03	01
Second Floor	42.03	0.00	42.03	0.00	42.03	42.03	42.03	00
Terrace Floor	0.00	0.00	0.00	0.00	0.00	0.00	0.00	00
Total :	126.09	32.89	84.06	9.14	93.20	93.20	93.20	01
Total Number of Same Buildings :	1							
Total :	126.09	32.89	84.06	9.14	93.20	93.20	93.20	01

SCHEDULE OF DOOR:

BUILDING NAME	NAME	LENGTH	HEIGHT	NOS
A (SRI MAHENDRA)	D3	0.80	2.10	02
A (SRI MAHENDRA)	D2	0.90	2.10	03
A (SRI MAHENDRA)	D1	1.05	2.10	02

SCHEDULE OF WINDOW/VENTILATION:

BUILDING NAME	NAME	LENGTH	HEIGHT	NOS
A (SRI MAHENDRA)	V	0.60	0.60	02
A (SRI MAHENDRA)	W4	0.90	1.20	03
A (SRI MAHENDRA)	W3	1.20	1.20	03
A (SRI MAHENDRA)	W2	1.50	2.10	02
A (SRI MAHENDRA)	W1	1.80	1.20	01

UnitBUA Table for Building :A (SRI MAHENDRA)

FLOOR	Name	UnitBUA Type	UnitBUA Area	Carpet Area	No. of Rooms	No. of Tenement
FIRST FLOOR PLAN	SPLIT A	FLAT	72.08	69.21	4	1
SECOND FLOOR PLAN	SPLIT A	FLAT	0.00	0.00	3	0
Total:	-	-	72.08	69.21	7	1

LTP NAME AND SIGNATURE	STRUCTURAL ENG'S NAME AND SIGNATURE	BUILDER NAME AND SIGNATURE	DIGITAL SIGNATURE
Ajit Kumar Dhar JNAC/DFTMN/0009/2017			

Proposal Basic Information	
Proposal File No.	JNAC/BP/0106/W11/2019
Owner Name	SRI MAHENDRA
Khata No	NIL
Plot No	272
Village Name	Sitaramdera
Use	Residential
SubUse	Semidetached

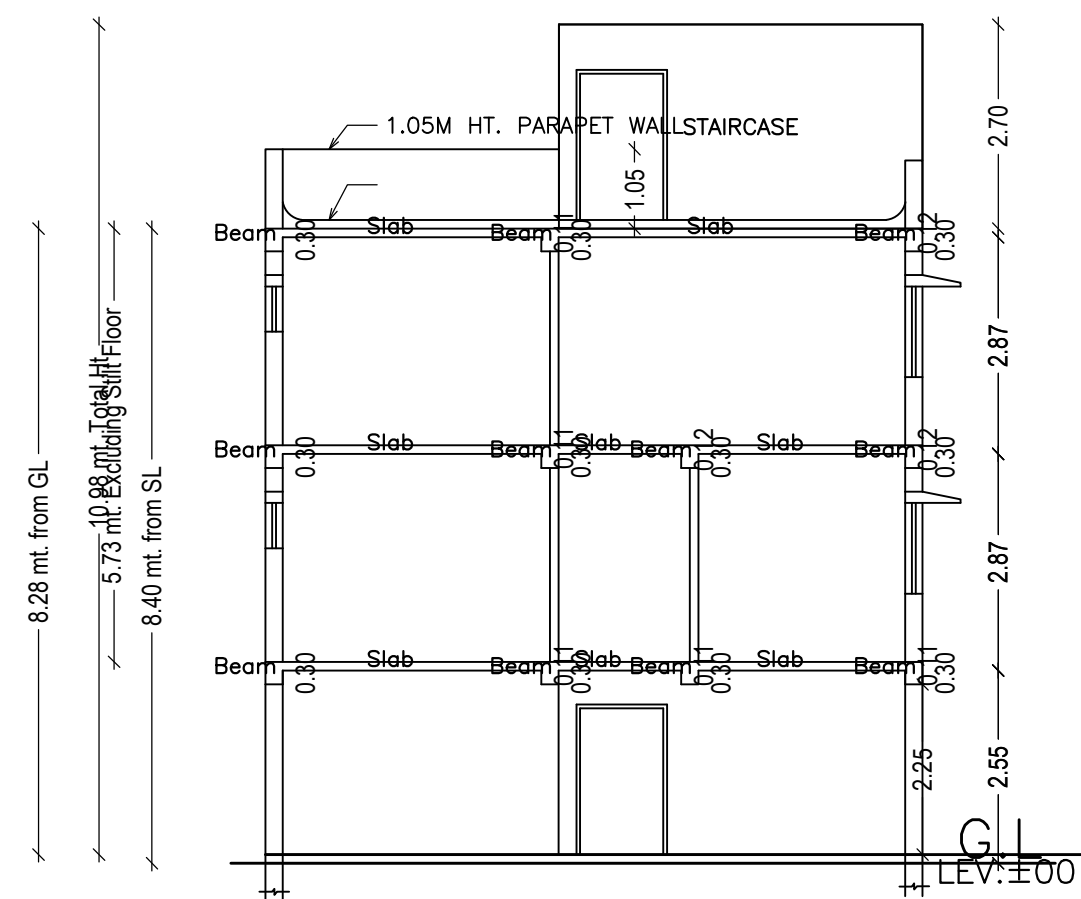

SECTION - Y-Y
SCALE=1:100

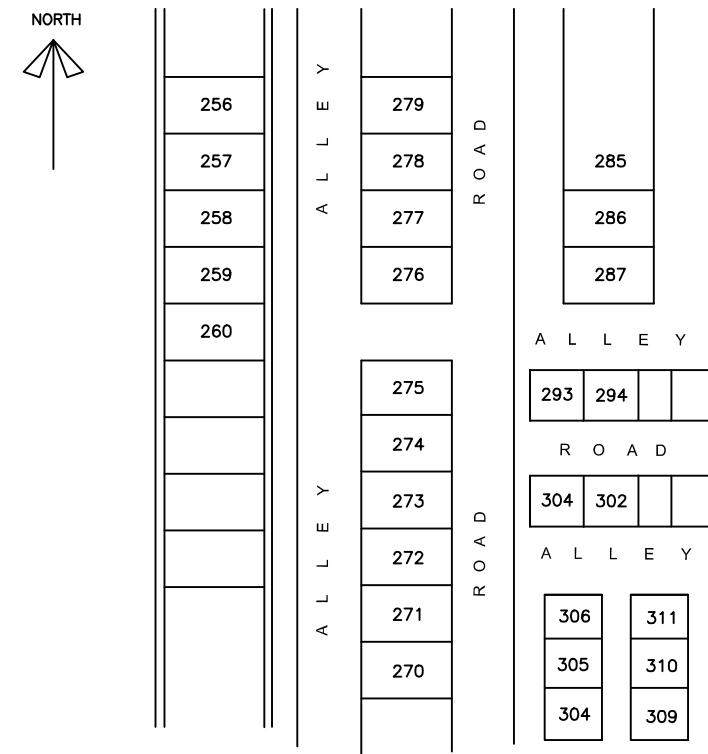
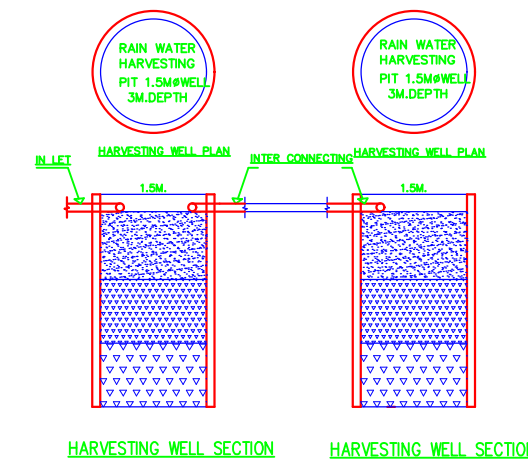

MOUZA PLAN
NOT TO SCALE

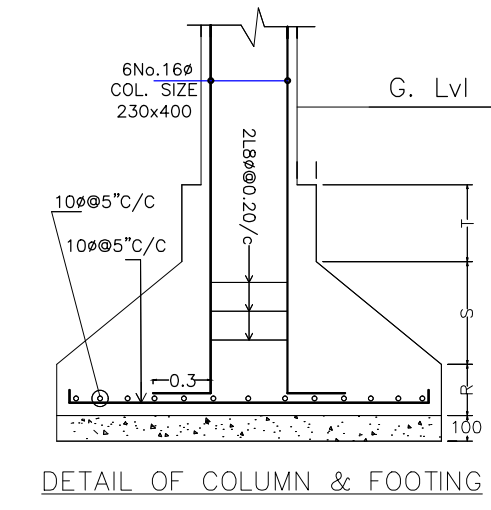

DETAIL OF COLUMN & FOOTING

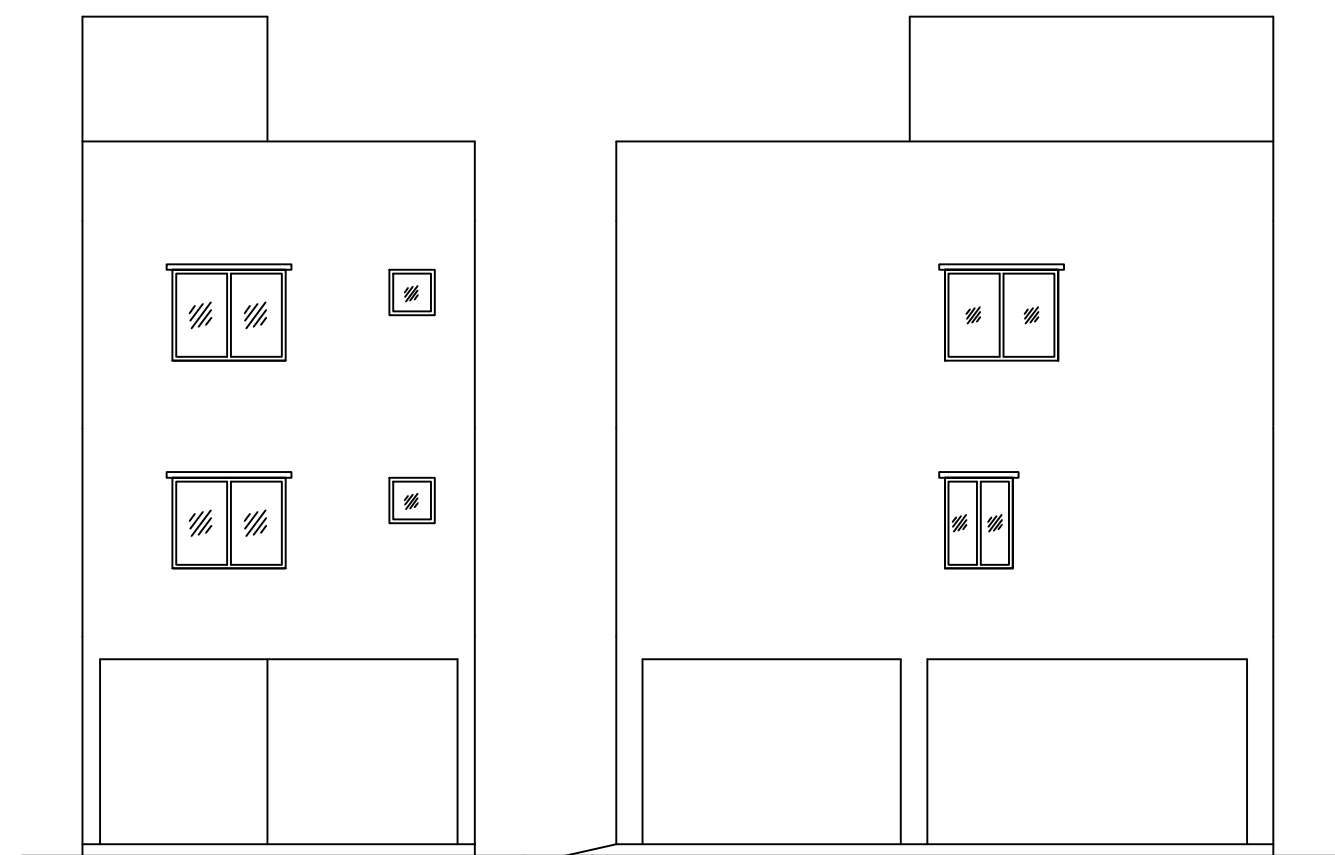

FRONT ELEVATION
SCALE=1:100

SIDE ELEVATION
SCALE=1:100

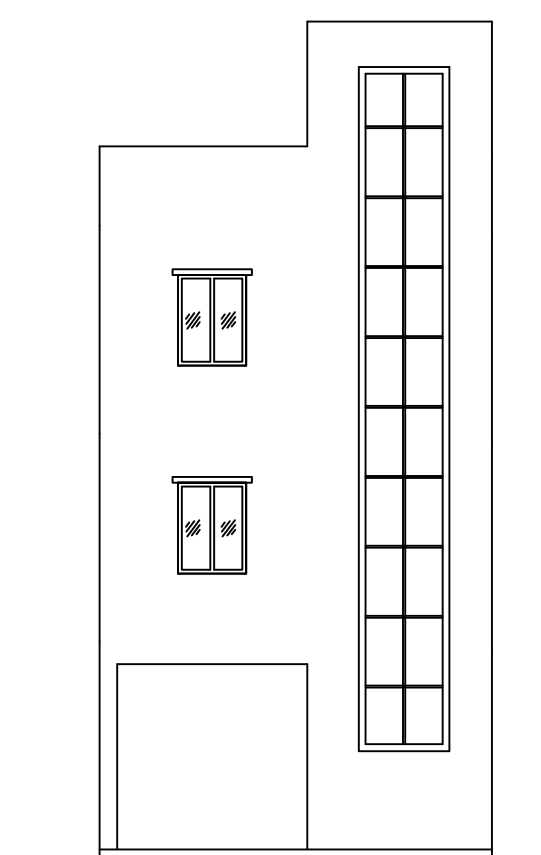

RARE SIDE ELEVATION
SCALE=1:100

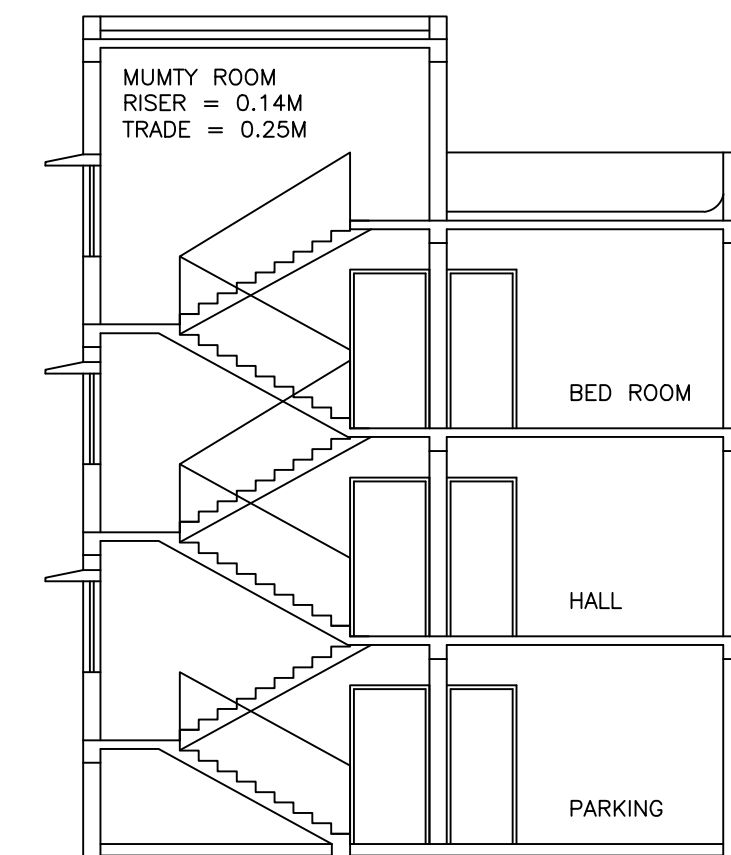

SECTION - X-X
SCALE=1:100

LTP NAME AND SIGNATURE	STRUCTURAL ENG'S NAME AND SIGNATURE	BUILDER NAME AND SIGNATURE	DIGITAL SIGNATURE
Ajit Kumar Dhar JNAC/DFTMN/0009/2017			