

Proposal Basic Information	
Proposal File No.	JNAC/BP/0100/W2/2019
Owner Name	SRI SANJAY KUMAR GUPTA AND SRI RAJU KUMAR GUPTA
Khata No	NIL
Plot No	C/70
Village Name	SONARI
Use	Residential
SubUse	Semidetached

COLOR INDEX	
PLOT BOUNDARY	
ABUTTING ROAD	
PROPOSED CONSTRUCTION	
COMMON PLOT	
ROAD WIDENING AREA	
EXISTING (To be retained)	
EXISTING (To be demolished)	

Buildingwise Floor FAR Details

Floor Name	Building Name A (SANJAY KUMAR GUPTA)		Total	
	Proposed Built Up Area (Sq.mt.)	Proposed FAR Area (Sq.mt.)	Total Proposed Built Up Area (Sq.mt.)	Total FAR Area (Sq.mt.)
Parking Floor	11.16	11.16	11.16	11.16
First Floor	71.61	71.61	71.61	71.61
Second Floor	71.61	71.61	71.61	71.61
Terrace Floor	0.00	0.00	0.00	0.00
Total :	154.38	154.38	154.38	154.38

Building USE/SUBUSE Details

Building Name	Building Use	Building SubUse	Building Structure
A (SANJAY KUMAR GUPTA)	Residential	Semidetached	Non-Highrise

FAR & Tenement Details (Table 4c-1)

Building	No. of Same Bldg	Total Built Up Area (Sq.mt.)	Proposed FAR Area (Sq.mt.)		Total FAR Area (Sq.mt.)	Total Consumed Additional FAR Area (Sq.mt.)	Tnmt (No.)
			Resi.	Stair			
A (SANJAY KUMAR GUPTA)	1	154.38	143.22	11.16	154.38	154.38	01
Grand Total :	1	154.38	143.22	11.16	154.38	154.38	01

AREA STATEMENT	VERSION NO. : 1.0.42
JAMSHEDPUR NAC	VERSION DATE: 29/04/2019
PROJECT DETAIL:	
Region: JHARKHAND URBAN LOCAL BODIES	Plot Use: Residential
District: EAST SINGHBHUM	Plot SubUse: Semidetached
Authority: JAMSHEDPUR NAC	Plot/Nearby/Religious/Structure: NA
Inward No: JNAC/BP/0100/W2/2019	Plot/SubPlot No: C/70
Application Type: General Proposal	North: Plot No. - C/71
Project Type: Building Permission	South: Plot No. - C/69
Nature of Development: New	East: Road Width - 4.5 M
Location of Development Area: Old Area	West: Road Width - 9.5 M
AREA DETAILS:	
AREA OF PLOT (Minimum)	(A) 111.42
NET AREA OF PLOT (Gross Plot Area - Deduction from Gross Plot area)	(A-Deductions) 111.42
Deduction for Balance Plot Area (from Gross Plot Area)	
Common Plot	9.91
Total	9.91
BALANCE AREA OF PLOT (Net Plot Area - Recreational/Amenity space)	(A-Deductions) 101.50
PLOT AREA FOR COVERAGE (Net Plot Area)	(A-Deductions) 111.42
Plot Area for FAR (Net Plot Area + Road Widening Area)	(A-Deductions) 111.42
COVERAGE CHECK	
Permissible Coverage area (70.00 %)	77.99
Proposed Coverage Area (64.27 %)	71.61
Total Prop. Coverage Area (64.27 %)	71.61
Balance coverage area (5.73 %)	6.38
FAR CHECK	
Perm. FAR Area (2.50)	278.55
Total Perm. FAR area	278.55
Residential FAR	143.21
Proposed FAR Area	154.37
Total Proposed FAR Area	154.37
Consumed FAR (Factor)	1.39
Balance FAR Area	124.18
BUILT UP AREA CHECK	
Total Proposed BuiltUp Area	154.38
ARCHITECT (Regd)	Shreyashi Haldar
ENGINEER (Regd)	
SUPERVISOR (Regd)	
OWNER (Regd)	SRI SANJAY KUMAR GUPTA AND SRI RAJU KUMAR GUPTA
DEVELOPMENT AUTHORITY	
LOCAL BODY	

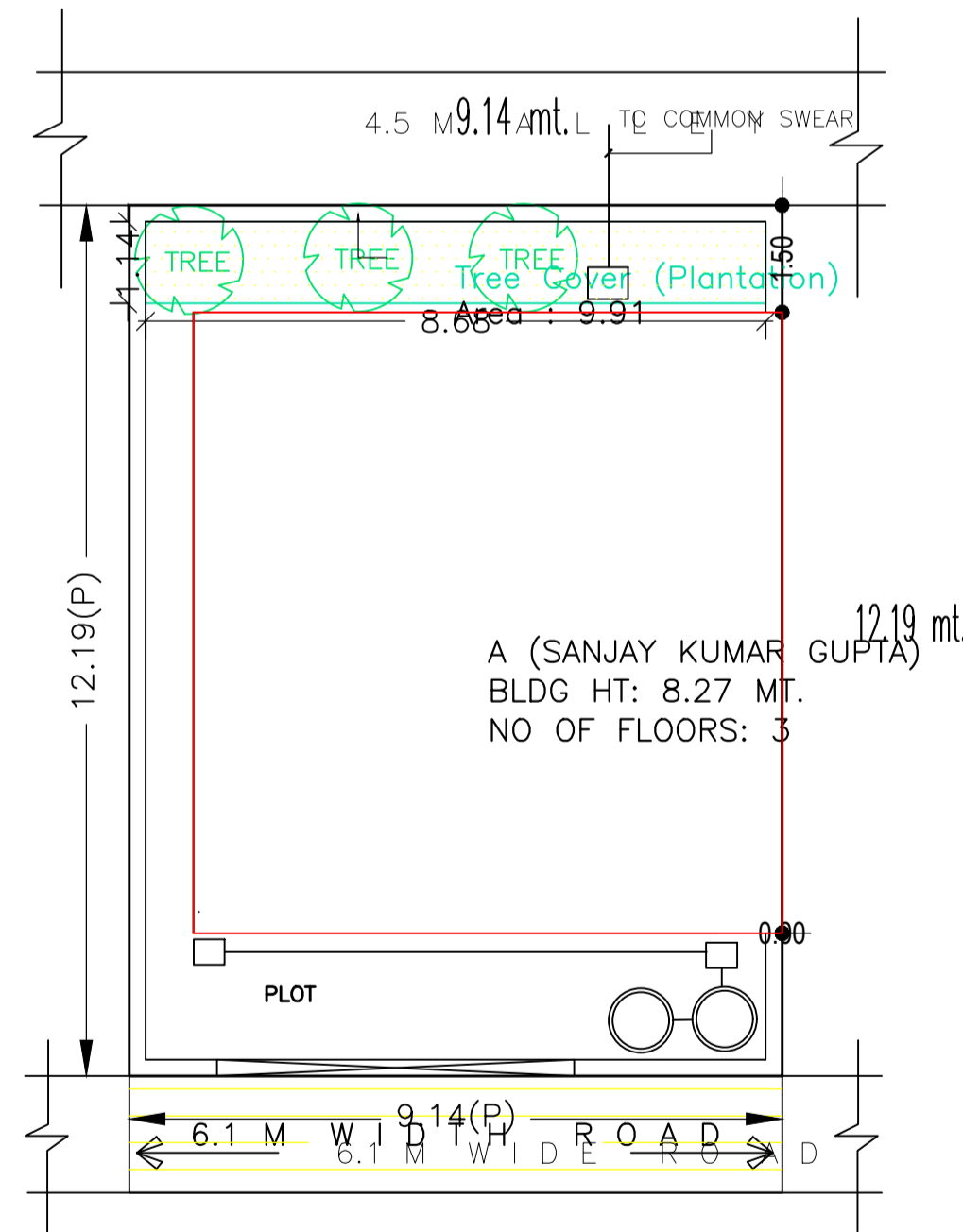

SITE PLAN
SCALE-1:100

SITE PLAN

LTP NAME AND SIGNATURE	STRUCTURAL ENG'S NAME AND SIGNATURE	BUILDER NAME AND SIGNATURE	DIGITAL SIGNATURE
Shreyashi Haldar JNAC/DFTMN/0009/2016			

Proposal Basic Information	
Proposal File No.	JNAC/BPI/0100/W2/2019
Owner Name	SRI SANJAY KUMAR GUPTA AND SRI RAJU KUMAR GUPTA
Khata No	NIL
Plot No	C/70
Village Name	SONARI
Use	Residential
SubUse	Semidetached

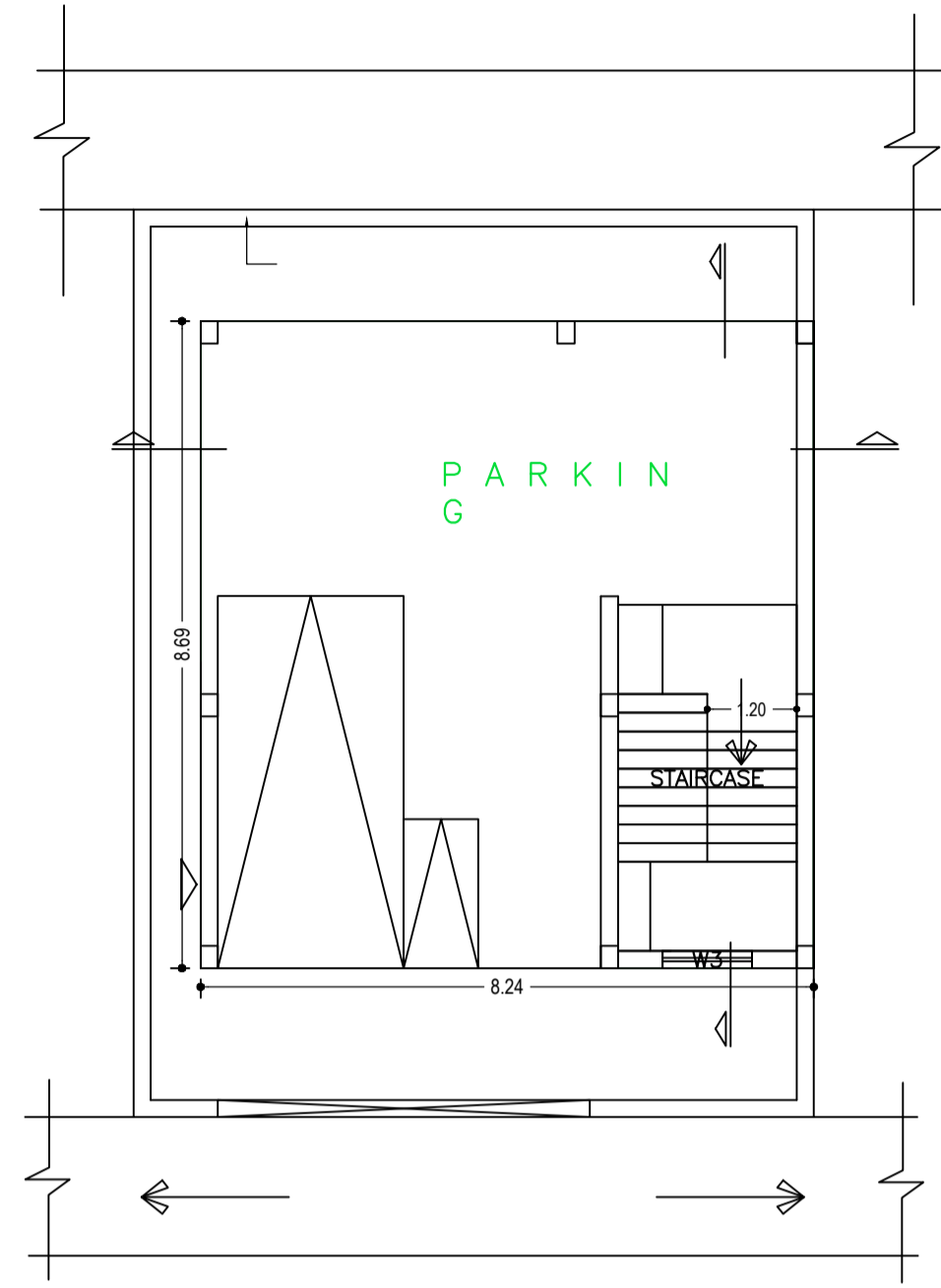

PARKING FLOOR PLAN
(SCALE 1:100)

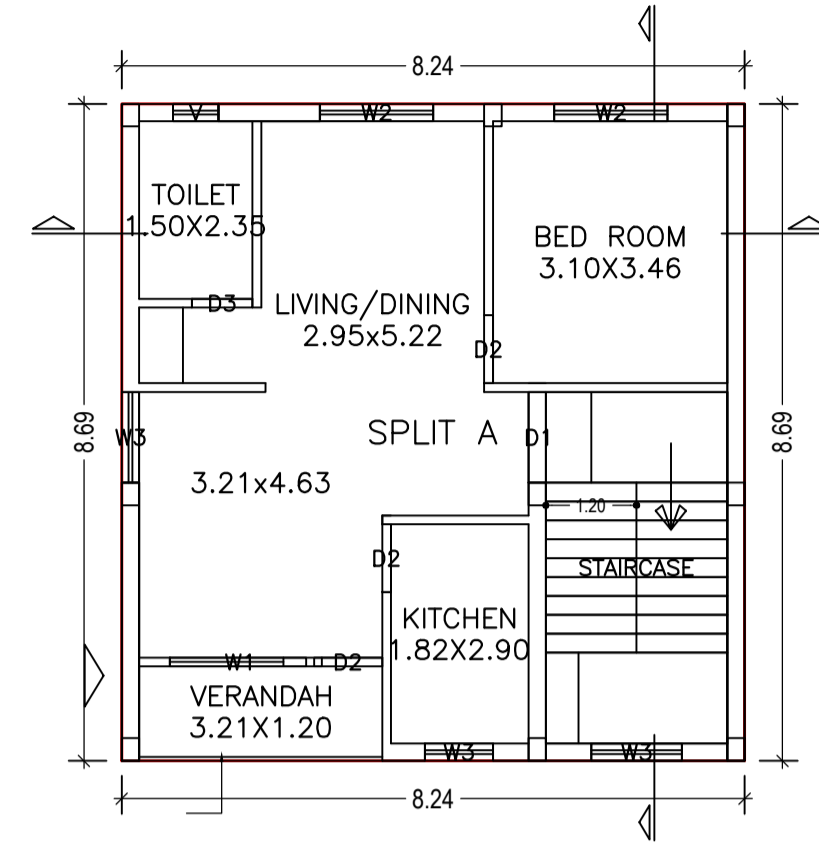

FIRST FLOOR PLAN
(Proposed)
(SCALE 1:100)

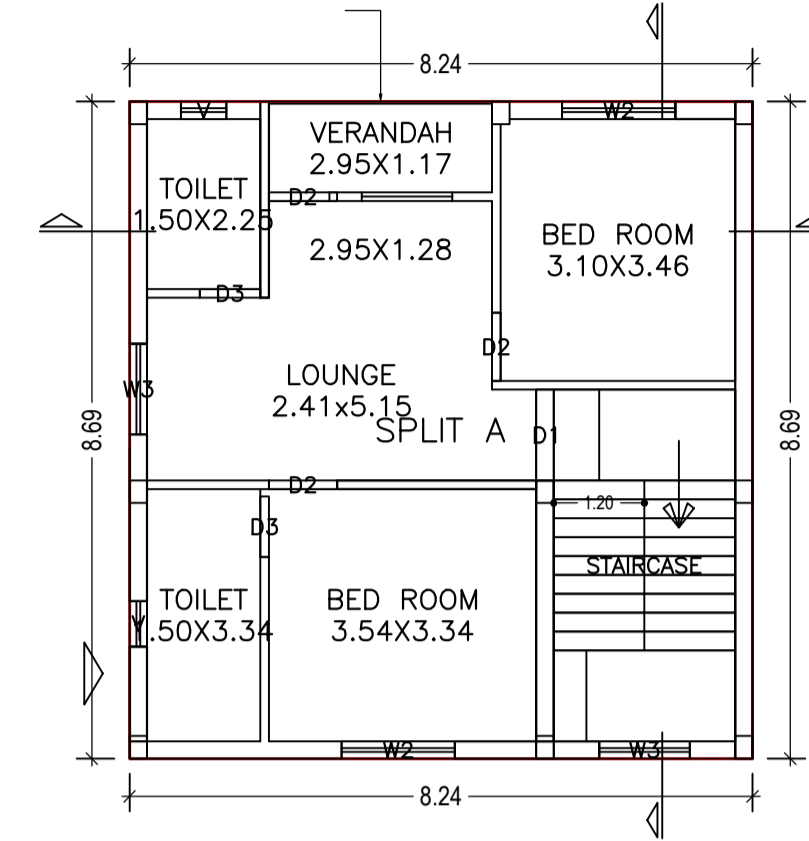

SECOND FLOOR PLAN
(Proposed)
(SCALE 1:100)

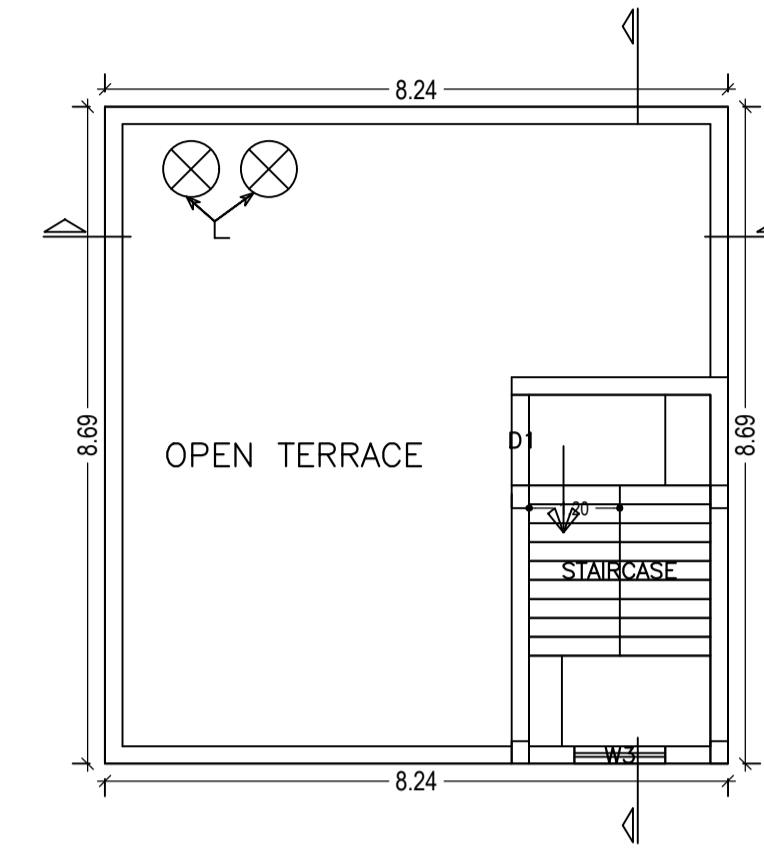

TERRACE FLOOR PLAN
(SCALE 1:100)

Building :A (SANJAY KUMAR GUPTA)

Floor Name	Total Built Up Area (Sq.mt.)	Proposed FAR Area (Sq.mt.)		Total FAR Area (Sq.mt.)	Total Consumed Additional FAR Area (Sq.mt.)	Trmt (No.)
		Resi.	Stair			
Parking Floor	11.16	0.00	11.16	11.16	11.16	00
First Floor	71.61	71.61	0.00	71.61	71.61	01
Second Floor	71.61	71.61	0.00	71.61	71.61	00
Terrace Floor	0.00	0.00	0.00	0.00	0.00	00
Total :	154.38	143.22	11.16	154.38	154.38	01
Total Number of Same Buildings :	1					
Total :	154.38	143.22	11.16	154.38	154.38	01

SCHEDULE OF DOOR:

BUILDING NAME	NAME	LENGTH	HEIGHT	NOS
A (SANJAY KUMAR GUPTA)	D3	0.80	2.10	03
A (SANJAY KUMAR GUPTA)	D2	0.90	2.10	06
A (SANJAY KUMAR GUPTA)	D1	1.20	2.10	01

SCHEDULE OF WINDOW/VENTILATION:

BUILDING NAME	NAME	LENGTH	HEIGHT	NOS
A (SANJAY KUMAR GUPTA)	V	0.60	0.60	03
A (SANJAY KUMAR GUPTA)	W3	0.90	1.20	01
A (SANJAY KUMAR GUPTA)	W3	1.20	1.20	06
A (SANJAY KUMAR GUPTA)	W2	1.50	1.20	04
A (SANJAY KUMAR GUPTA)	W1	1.80	1.20	01

LTP NAME AND SIGNATURE	STRUCTURAL ENG'S NAME AND SIGNATURE	BUILDER NAME AND SIGNATURE	DIGITAL SIGNATURE
Shreyashi Haldar JNAC/DFTMN/0009/2016			

Proposal Basic Information	
Proposal File No.	JNAC/BP/0100/W2/2019
Owner Name	SRI SANJAY KUMAR GUPTA AND SRI RAJU KUMAR GUPTA
Khata No	NIL
Plot No	C/70
Village Name	SONARI
Use	Residential
SubUse	Semidetached

UnitBUA Table for Building :A (SANJAY KUMAR GUPTA)

FLOOR	Name	UnitBUA Type	UnitBUA Area	Carpet Area	No. of Rooms	No. of Tenement
FIRST FLOOR PLAN	SPLIT A	FLAT	143.21	134.51	5	1
SECOND FLOOR PLAN	SPLIT A	FLAT	0.00	0.00	6	0
Total	-	-	143.21	134.51	11	1

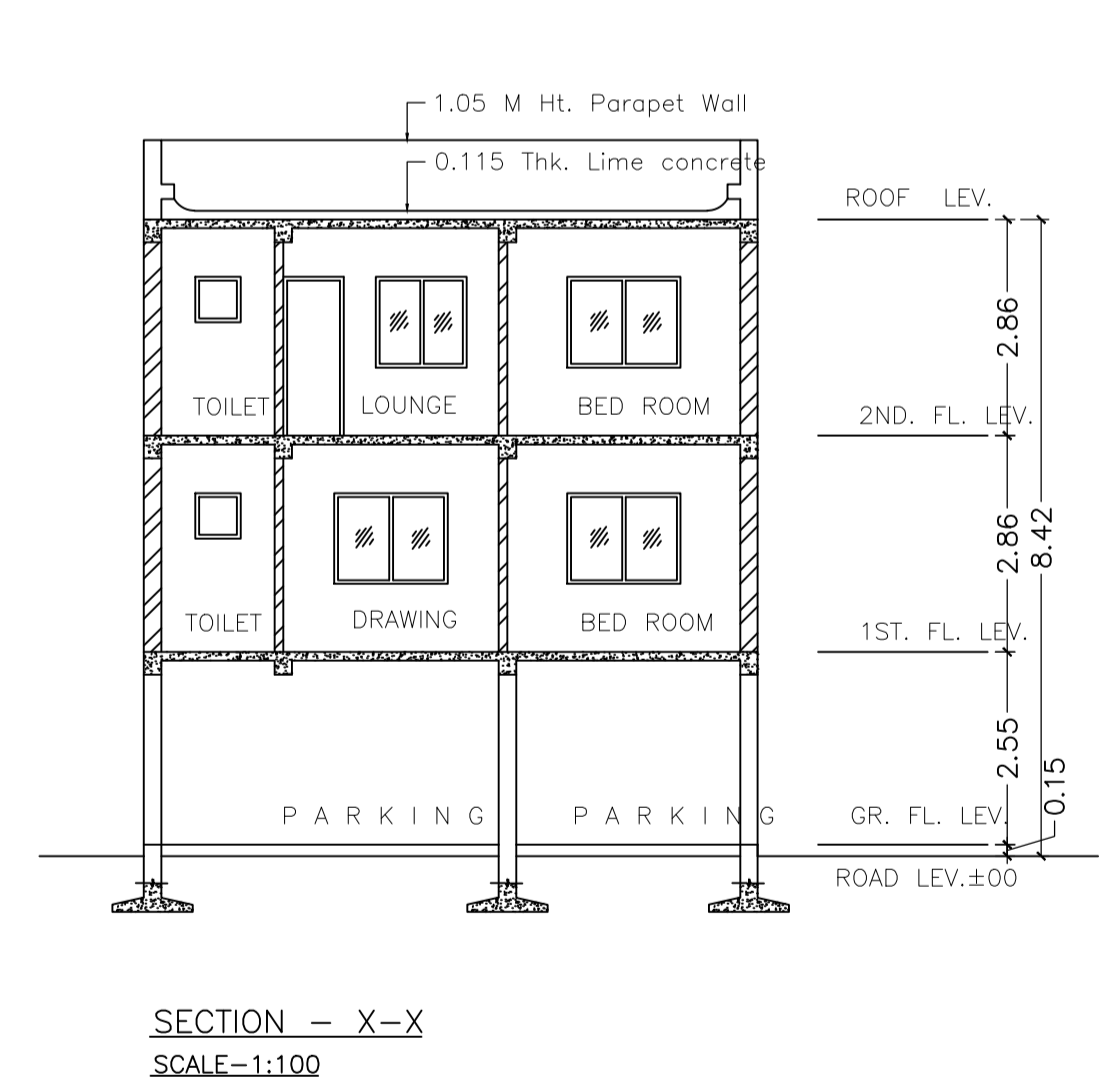
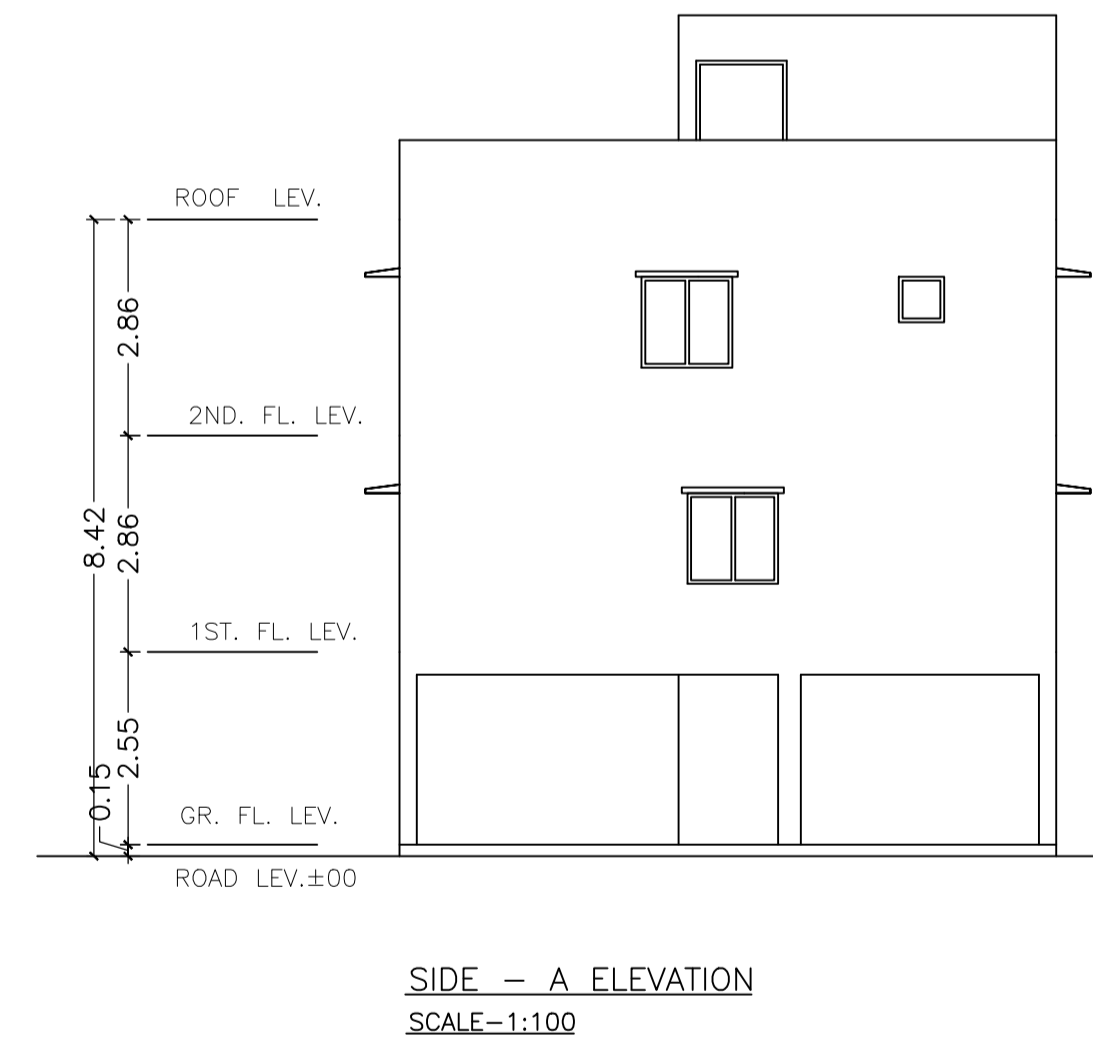
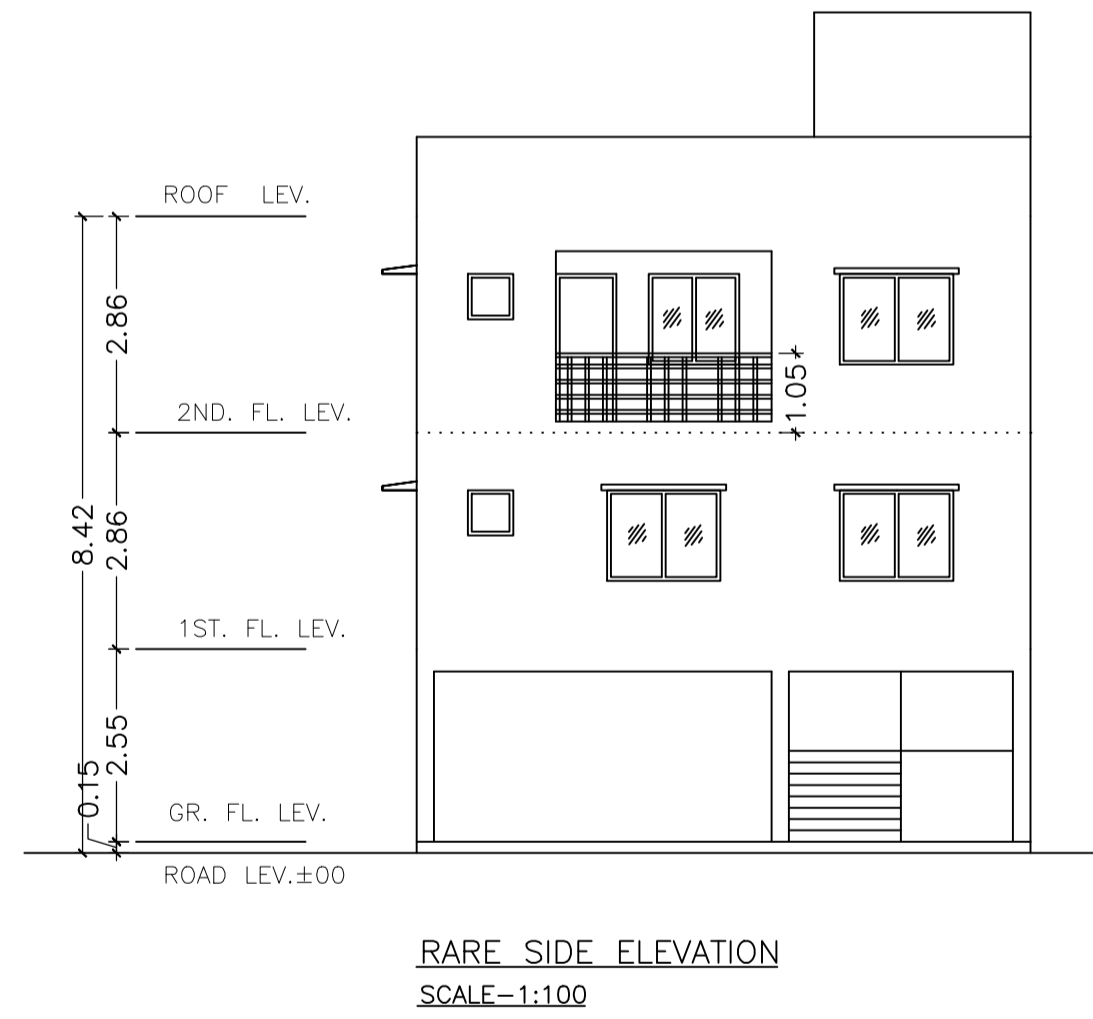
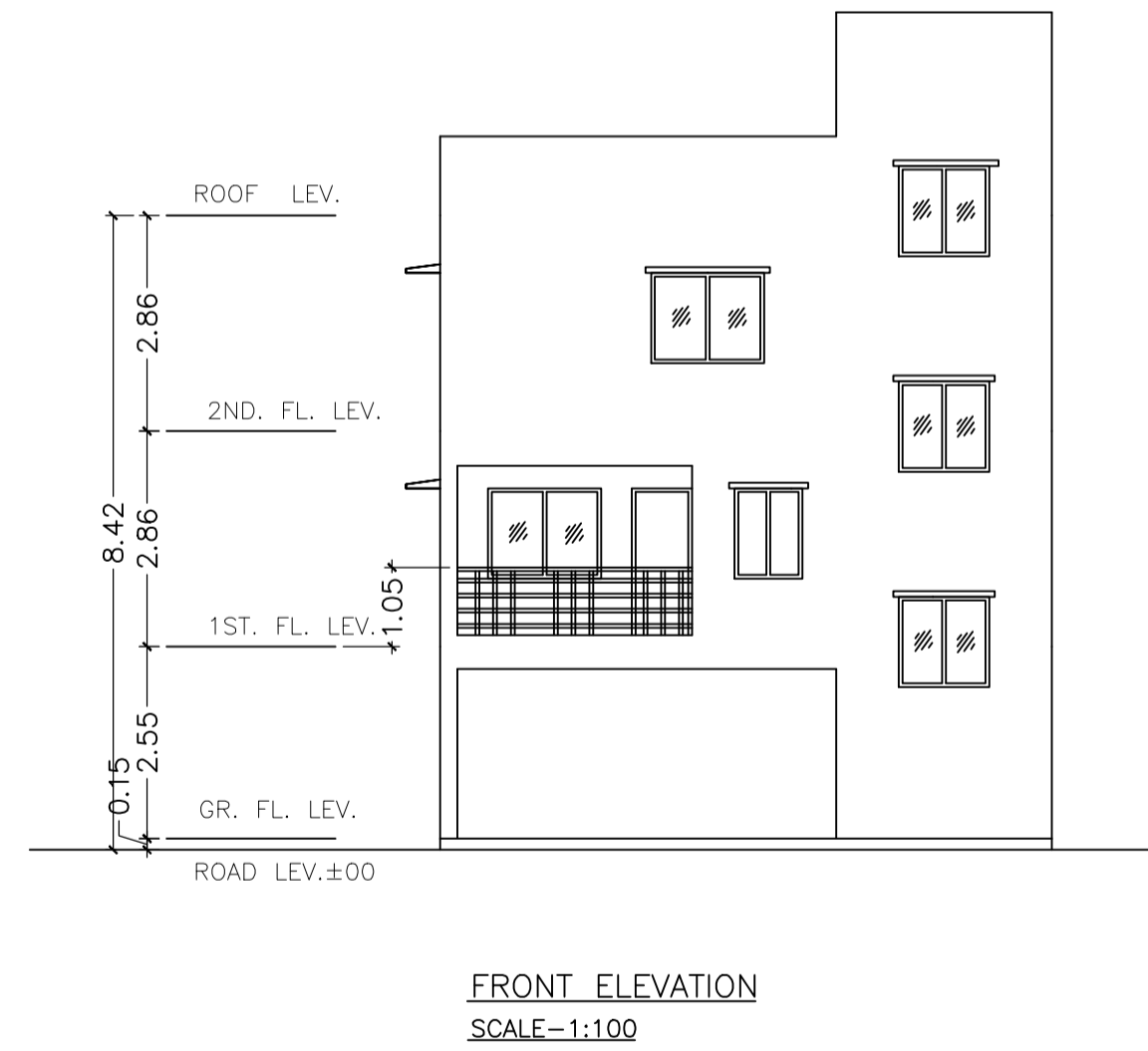
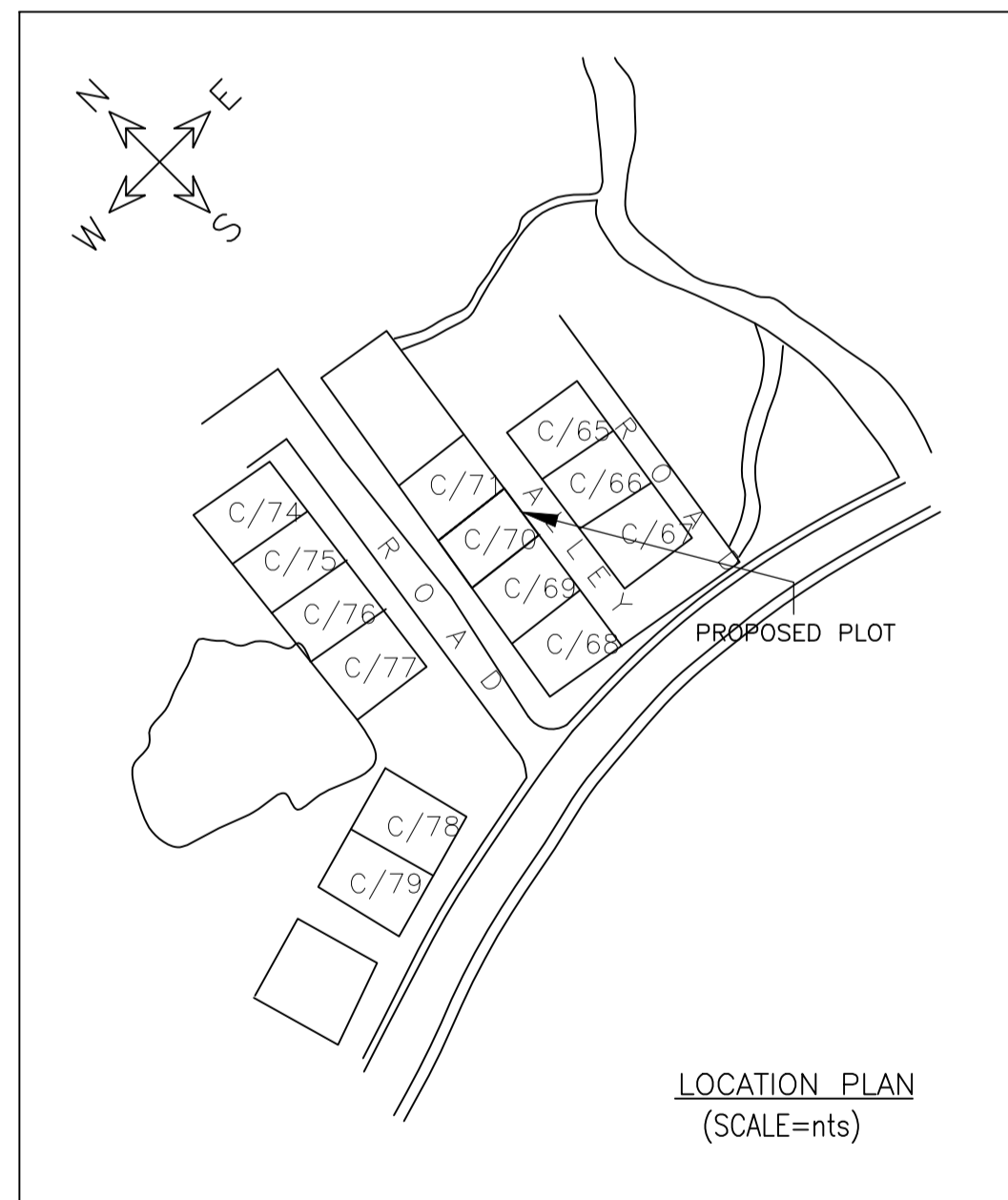
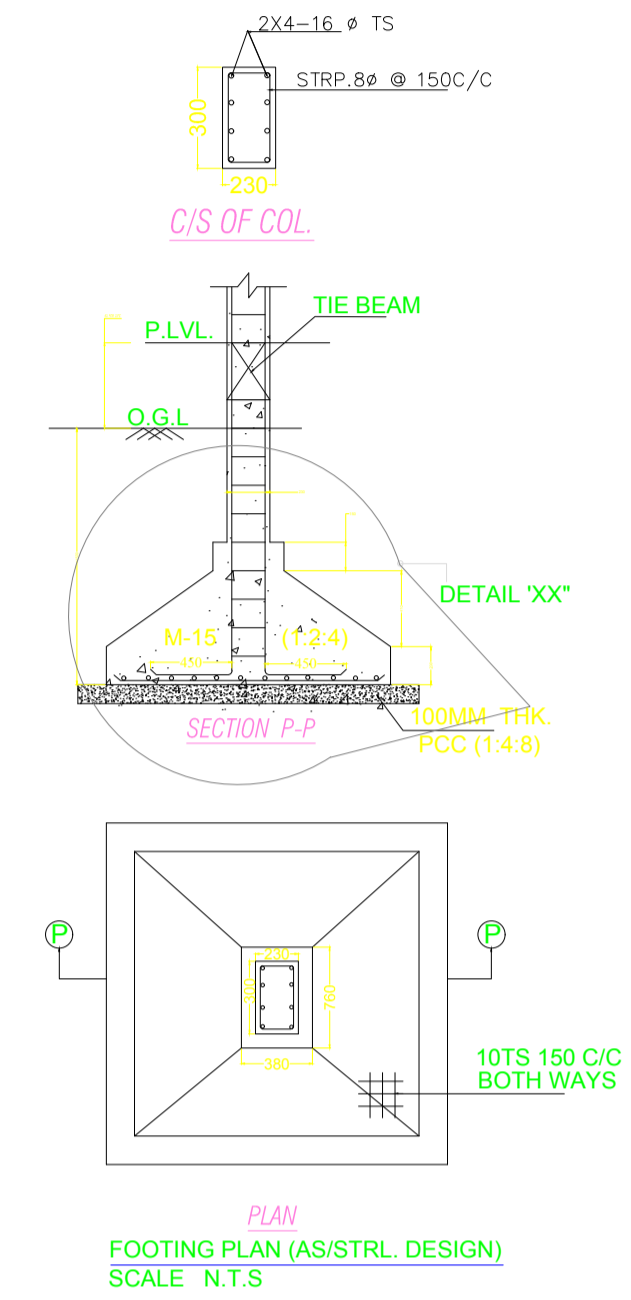
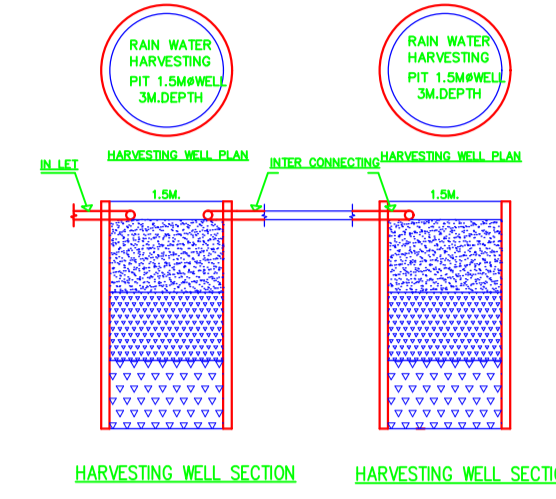
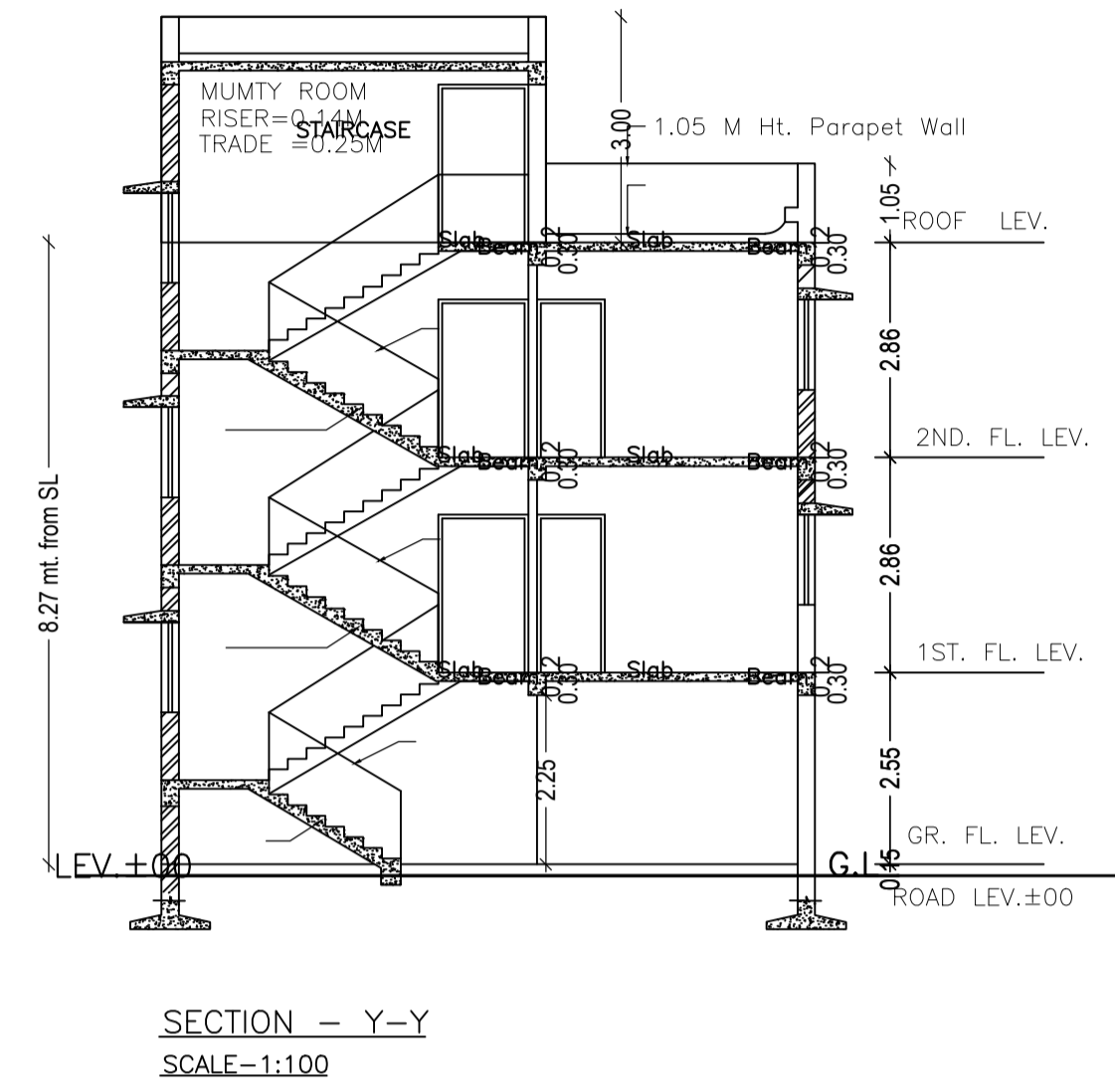

LTP NAME AND SIGNATURE	STRUCTURAL ENG'S NAME AND SIGNATURE	BUILDER NAME AND SIGNATURE	DIGITAL SIGNATURE
Shreyashi Halder JNAC/DFTMN/0009/2016			