

SITE PLAN

(Scale - 1:200)

FAR & Tenement Details (Table 4c-1)

Building	No. of Same Bldg	Total Built Up Area (Sq.mt.)	Deductions (Area in Sq.mt.)		Proposed FAR Area (Sq.mt.)	Add Area In FAR (Sq.mt.)	Total FAR Area (Sq.mt.)	Total Consumed Additional FAR Area (Sq.mt.)	Trmnt (No.)
			Parking	Resi.					
A (ARATI DE)	1	115.29	27.27	76.86	11.16	88.02	88.02	01	
Grand Total :	1	115.29	27.27	76.86	11.16	88.02	88.02	01	

Proposal Basic Information

Proposal File No.	JNAC/BP/0096/W11/2019
Owner Name	ARATI DE
Khata No	245
Plot No	Ho. No. 122, NEW SITARAMDERA AREA
Village Name	Sitaramdera
Use	Residential
SubUse	Bungalow/ Dwelling / Non Apartment

AREA STATEMENT JAMSHEDPUR NAC	VERSION NO. : 1.0.42 VERSION DATE: 29/04/2019
PROJECT DETAIL:	
Region: JHARKHAND URBAN LOCAL BODIES	Plot Use: Residential
District: EAST SINGHBHUM	Plot SubUse: Bungalow/ Dwelling / Non Apartment
Authority: JAMSHEDPUR NAC	PlotNearby/ReligiousStructure: NA
Inward_No: JNAC/BP/0096/W11/2019	PlotSubPlot No: Ho. No. 122, NEW SITARAMDERA AREA
Application Type: General Proposal	North: Plot No. - Ho. No. 110A
Project Type: Building Permission	South: Road Width - 9
Nature of Development: New	East: Road Width - ROAD AND HUT
Location of Development Area: Old Area	West: Road Width - 6 MTRS ALLEY
AREA DETAILS:	
AREA OF PLOT (Minimum)	(A) 74.35
NET AREA OF PLOT(Gross Plot Area - Deduction from Gross Plot area)	(A-Deductions) 74.35
Deduction for Balance Plot Area(from Gross Plot Area)	
Common Plot	9.04
Total	9.04
BALANCE AREA OF PLOT(Net Plot Area - Recreational/Amenity space)	(A-Deductions) 65.31
PLOT AREA FOR COVERAGE(Net Plot Area)	(A-Deductions) 74.35
Plot Area for FAR (Net Plot Area + RoadWidening Area)	(A-Deductions) 74.35
COVERAGE CHECK	
Permissible Coverage area (70.00 %)	52.04
Proposed Coverage Area (51.69 %)	38.43
Total Prop. Coverage Area (51.69 %)	38.43
Balance coverage area (18.31 %)	13.61
FAR CHECK	
Perm. FAR Area (2.50)	185.88
Total Perm. FAR area	185.88
Residential FAR	76.86
Proposed FAR Area	88.02
Total Proposed FAR Area	88.02
Consumed FAR (Factor)	1.18
Balance FAR Area	97.86
BUILT UP AREA CHECK	
Total Proposed BuiltUp Area	115.29
ARCHITECT (Regd)	SUDIPTO MUKHERJEE
ENGINEER (Regd)	
SUPERVISOR (Regd)	
OWNER (Regd)	ARATI DE
DEVELOPMENT AUTHORITY	LOCAL BODY

COLOR INDEX	
PLOT BOUNDARY	Black
ABUTTING ROAD	Green
PROPOSED CONSTRUCTION	Red
COMMON PLOT	Yellow
ROAD WIDENING AREA	Orange
EXISTING (To be retained)	Blue
EXISTING (To be demolished)	Light Blue

Buildingwise Floor FAR Details

Floor Name	Building Name A (ARATI DE)		Total	
	Proposed Built Up Area (Sq.mt.)	Proposed FAR Area (Sq.mt.)	Total Proposed Built Up Area (Sq.mt.)	Total FAR Area (Sq.mt.)
Parking Floor	38.43	11.16	38.43	11.16
First Floor	38.43	38.43	38.43	38.43
Second Floor	38.43	38.43	38.43	38.43
Terrace Floor	0.00	0.00	0.00	0.00
Total :	115.29	88.02	115.29	88.02

Building USE/SUBUSE Details

Building Name	Building Use	Building SubUse	Building Structure
A (ARATI DE)	Residential	Bungalow/ Dwelling / Non Apartment	Non-Highrise

LTP NAME AND SIGNATURE	STRUCTURAL ENG'S NAME AND SIGNATURE	BUILDER NAME AND SIGNATURE	DIGITAL SIGNATURE
SUDIPTO MUKHERJEE JNAC/ENG/0013/2019			

Proposal Basic Information

Proposal File No.	JNAC/BP/0096/W11/2019
Owner Name	ARATI DE
Khata No	245
Plot No	Ho. No. 122, NEW SITARAMDERA AREA
Village Name	Sitaramdera
Use	Residential
SubUse	Bungalow/ Dwelling / Non Apartment

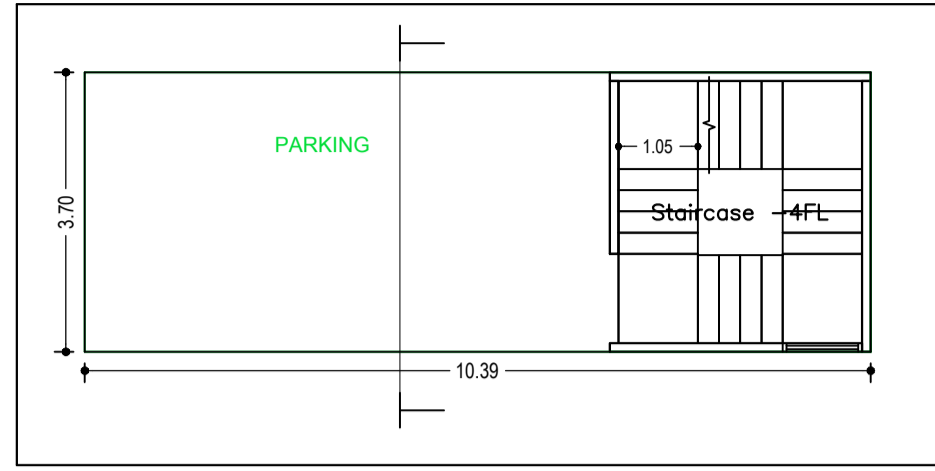

PARKING FLOOR PLAN
(SCALE 1:100)

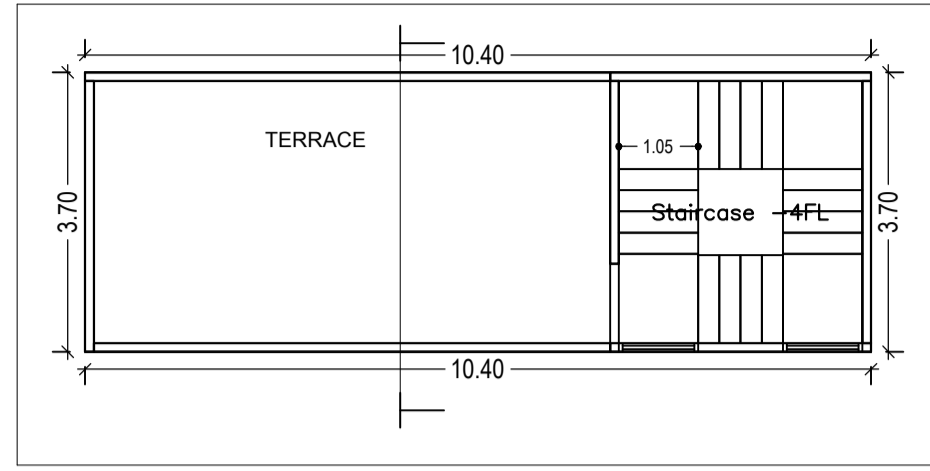

TERRACE FLOOR PLAN
(SCALE 1:100)

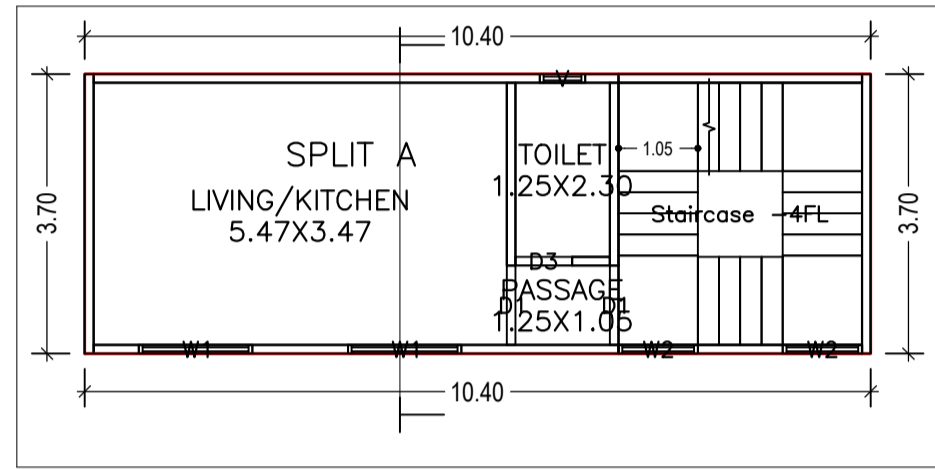

FIRST FLOOR PLAN
(Proposed)
(SCALE 1:100)

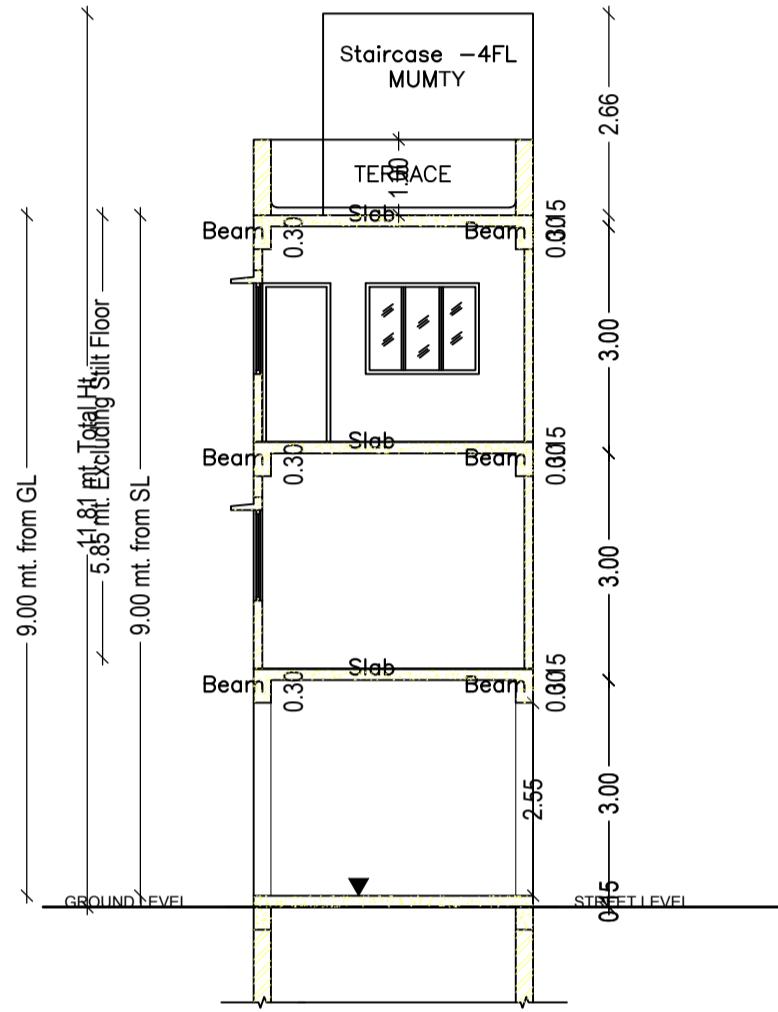

SECTION

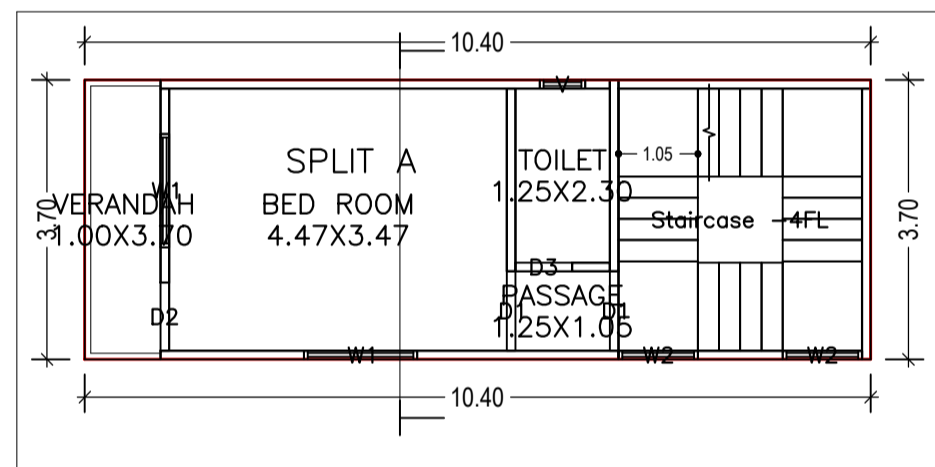

SECOND FLOOR PLAN
(Proposed)
(SCALE 1:100)



LOCATION PLAN

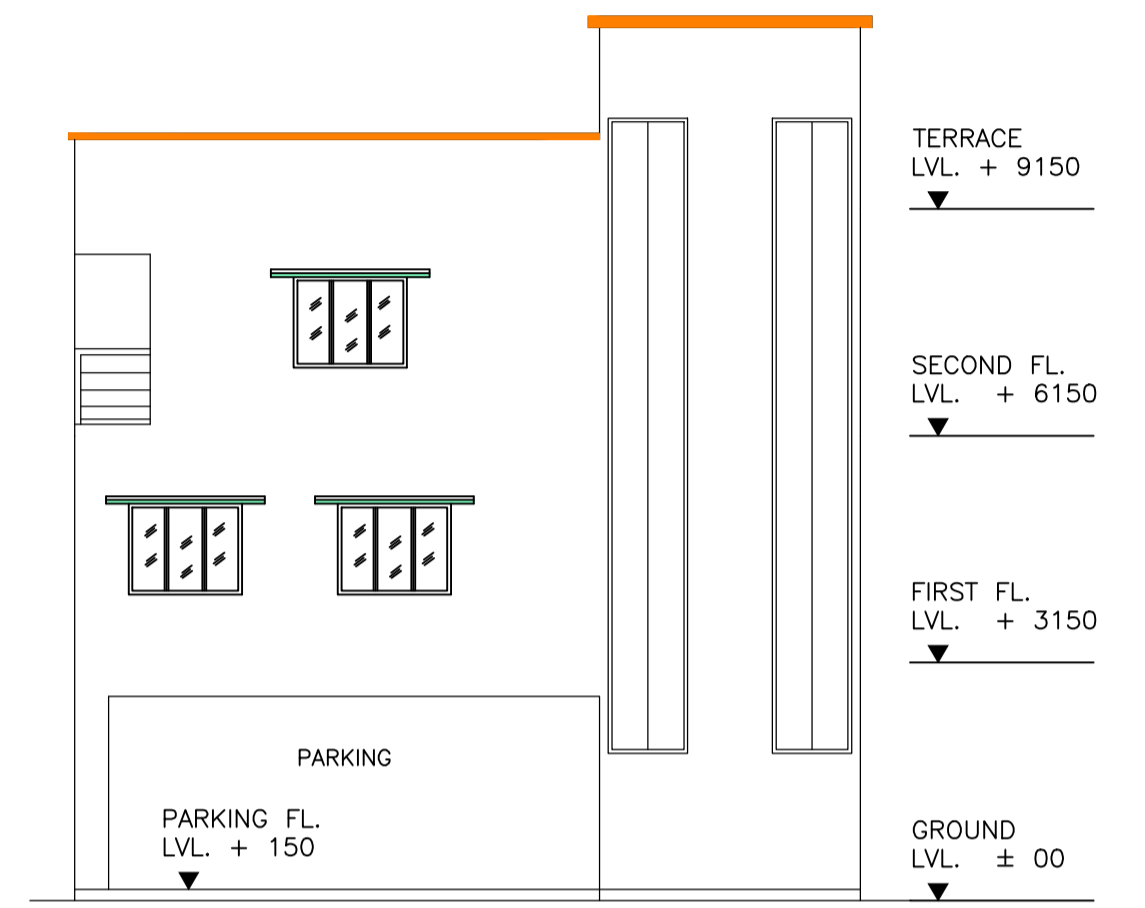

FRONT SIDE ELEVATION

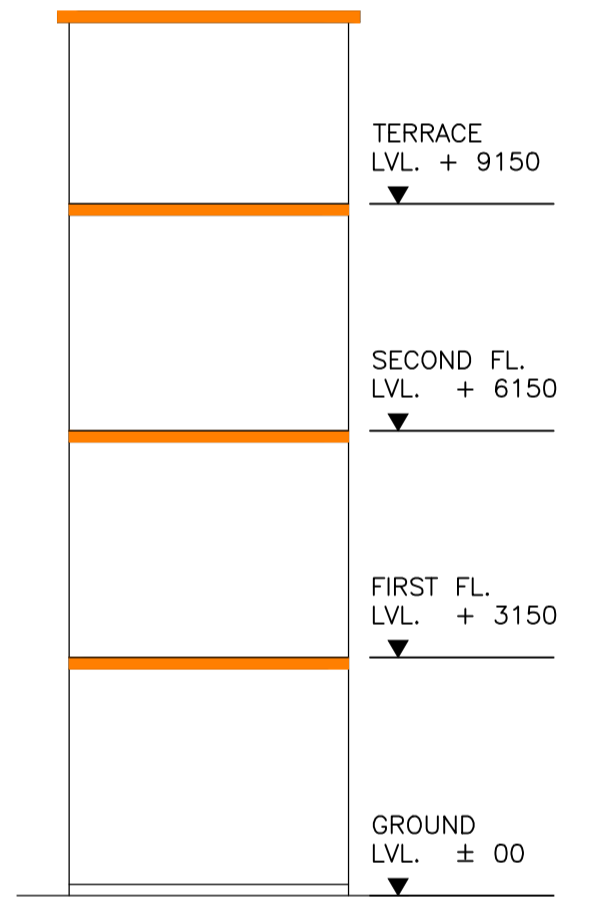

RIGHT SIDE ELEVATION

Building :A (ARATI DE)

Floor Name	Total Built Up Area (Sq.mt.)	Deductions (Area in Sq.mt.)		Proposed FAR Area (Sq.mt.)	Add Area In FAR (Sq.mt.)		Total FAR Area (Sq.mt.)	Total Consumed Additional FAR Area (Sq.mt.)	Trmt (No.)
		Parking	Resi.		Stair	Other			
Parking Floor	38.43	27.27	0.00	11.16	11.16	0.00	11.16	0.00	00
First Floor	38.43	0.00	38.43	0.00	38.43	38.43	38.43	0.00	01
Second Floor	38.43	0.00	38.43	0.00	38.43	38.43	38.43	0.00	00
Terrace Floor	0.00	0.00	0.00	0.00	0.00	0.00	0.00	0.00	00
Total :	115.29	27.27	76.86	11.16	88.02	88.02	88.02	01	
Total Number of Same Buildings	1								
Total :	115.29	27.27	76.86	11.16	88.02	88.02	88.02	01	

SCHEDULE OF DOOR:

BUILDING NAME	NAME	LENGTH	HEIGHT	NOS
A (ARATI DE)	D3	0.75	2.10	02
A (ARATI DE)	D2	0.90	2.10	01
A (ARATI DE)	D1	1.05	2.10	04

SCHEDULE OF WINDOW/VENTILATION:

BUILDING NAME	NAME	LENGTH	HEIGHT	NOS
A (ARATI DE)	V	0.60	0.60	02
A (ARATI DE)	W2	1.05	1.20	04
A (ARATI DE)	W1	1.50	1.20	04

UnitBUA Table for Building :A (ARATI DE)

FLOOR	Name	UnitBUA Type	UnitBUA Area	Carpet Area	No. of Rooms	No. of Tenement
FIRST FLOOR PLAN	SPLIT A	FLAT	52.20	47.26	3	1
SECOND FLOOR PLAN	SPLIT A	FLAT	0.00	0.00	4	0
Total:	-	-	52.20	47.26	7	1

LTP NAME AND SIGNATURE	STRUCTURAL ENG'S NAME AND SIGNATURE	BUILDER NAME AND SIGNATURE	DIGITAL SIGNATURE
SUDIPTO MUKHERJEE JNAC/ENG/0013/2019			