

Proposal Basic Information	
Proposal File No.	JNAC/BP/0097/W7/2019
Owner Name	RAMAKRISHNA MISSION VIVEKANANDA SOCIETY VIVEKANANDA ENGLISH HIGH SCHOOL
Khata No	245
Plot No	1109
Village Name	SAKCHI
Use	Educational
SubUse	School

AREA STATEMENT		VERSION NO.: 1.0.43
JAMSHEDPUR NAC		VERSION DATE: 29/04/2019
PROJECT DETAIL:		
Region: JHARKHAND URBAN LOCAL BODIES	Plot Use: Educational	
District: EAST SINGHBHUM	Plot SubUse: School	
Authority: JAMSHEDPUR NAC	PlotNearbyReligiousStructure: NA	
Inward_No: JNAC/BP/0097/W7/2019	Plot/SubPlot No: 1109	
Application Type: General Proposal	North: -	
Project Type: Building Permission	South: -	
Nature of Development: New	East: -	
Location of Development Area: Old Area	West: -	
AREA DETAILS:		
AREA OF PLOT (Minimum)	(A)	SQ.MT. 2781.00
NET AREA OF PLOT(Gross Plot Area - Deduction from Gross Plot area)	(A-Deductions)	2781.00
Deduction for Balance Plot Area(from Gross Plot Area)		
Common Plot		300.16
Total		300.16
BALANCE AREA OF PLOT(Net Plot Area - Recreational/Amenity space)	(A-Deductions)	2480.84
PLOT AREA FOR COVERAGE(Net Plot Area)	(A-Deductions)	2781.00
Plot Area for FAR (Net Plot Area + RoadWidening Area)	(A-Deductions)	2781.00
COVERAGE CHECK		
Permissible Coverage area (50.00 %)		1390.50
Proposed Coverage Area (49.22 %)		1368.88
Total Prop. Coverage Area (49.22 %)		1368.88
Balance coverage area (0.78 %)		21.62
FAR CHECK		
Perm. FAR Area (2.25)		6257.25
Total Perm. FAR area		6257.25
Special FAR		3329.12
Proposed FAR Area		3329.12
Total Proposed FAR Area		3329.12
Consumed FAR (Factor)		1.20
Balance FAR Area		2928.13
BUILT UP AREA CHECK		
Total Proposed BuiltUp Area		3598.12
ARCHITECT (Regd)	LAWRENCE FRANCIS	
ENGINEER (Regd)		
SUPERVISOR (Regd)		
OWNER (Regd)	RAMAKRISHNA MISSION VIVEKANANDA SOCIETY VIVEKANANDA ENGLISH HIGH SCHOOL	
DEVELOPMENT AUTHORITY	LOCAL BODY	

COLOR INDEX	
PLOT BOUNDARY	Black
ABUTTING ROAD	Green
PROPOSED CONSTRUCTION	Red
COMMON PLOT	Yellow
ROAD WIDENING AREA	Orange
EXISTING (To be retained)	Blue
EXISTING (To be demolished)	Light Blue

Floor Name	Building Name		Total	
	Proposed Built Up Area (Sq.mt.)	Proposed FAR Area (Sq.mt.)	Total Proposed Built Up Area (Sq.mt.)	Total FAR Area (Sq.mt.)
Ground Floor	1368.88	1106.33	1368.88	1106.33
First Floor	1114.62	1111.39	1114.62	1111.39
Second Floor	1114.62	1111.39	1114.62	1111.39
Terrace Floor	0.00	0.00	0.00	0.00
Total :	3598.12	3329.11	3598.12	3329.11

Building USE/SUBUSE Details

Building Name	Building Use	Building SubUse	Building Structure
A (VIVEKANANDA ENGLISH SCHOOL)	Educational	School	Non-Highrise

Required Parking(Table 7a)

Building Name	Type	SubUse	Area (Sq.mt.)	Units		Car		
				Reqd.	Prop.	Reqd./Unit	Reqd.	Prop.
A (VIVEKANANDA ENGLISH SCHOOL)	Educational	School	> 0	70	-	1	-	
				> 0	70	-	-	-
Total :				-	-	-	0	3

Parking Check (Table 7b)

Vehicle Type	Reqd.		Prop.	
	No.	Area	No.	Area
Car	-	-	3	37.50
Total Car	-	-	3	37.50
Other Parking	-	-	-	49.35
Total	0.00	-	-	86.85

FAR & Tenement Details (Table 4c-1)

Building	No. of Same Bldg	Gross Built Up Area (Sq.mt.)	Deductions From Gross BUA/Area in Sq.mt. Cutout	Total Built Up Area (Sq.mt.)	Deductions (Area in Sq.mt.)		Proposed FAR Area (Sq.mt.)	Total FAR Area (Sq.mt.)	Total Consumed Additional FAR Area (Sq.mt.)	Tnmt (No.)
					Lift	Void				
A (VIVEKANANDA ENGLISH SCHOOL)	1	4161.46	563.34	3598.12	6.46	262.55	3329.12	3329.11	3329.11	03
Grand Total :	1	4161.46	563.34	3598.12	6.46	262.55	3329.12	3329.11	3329.11	03

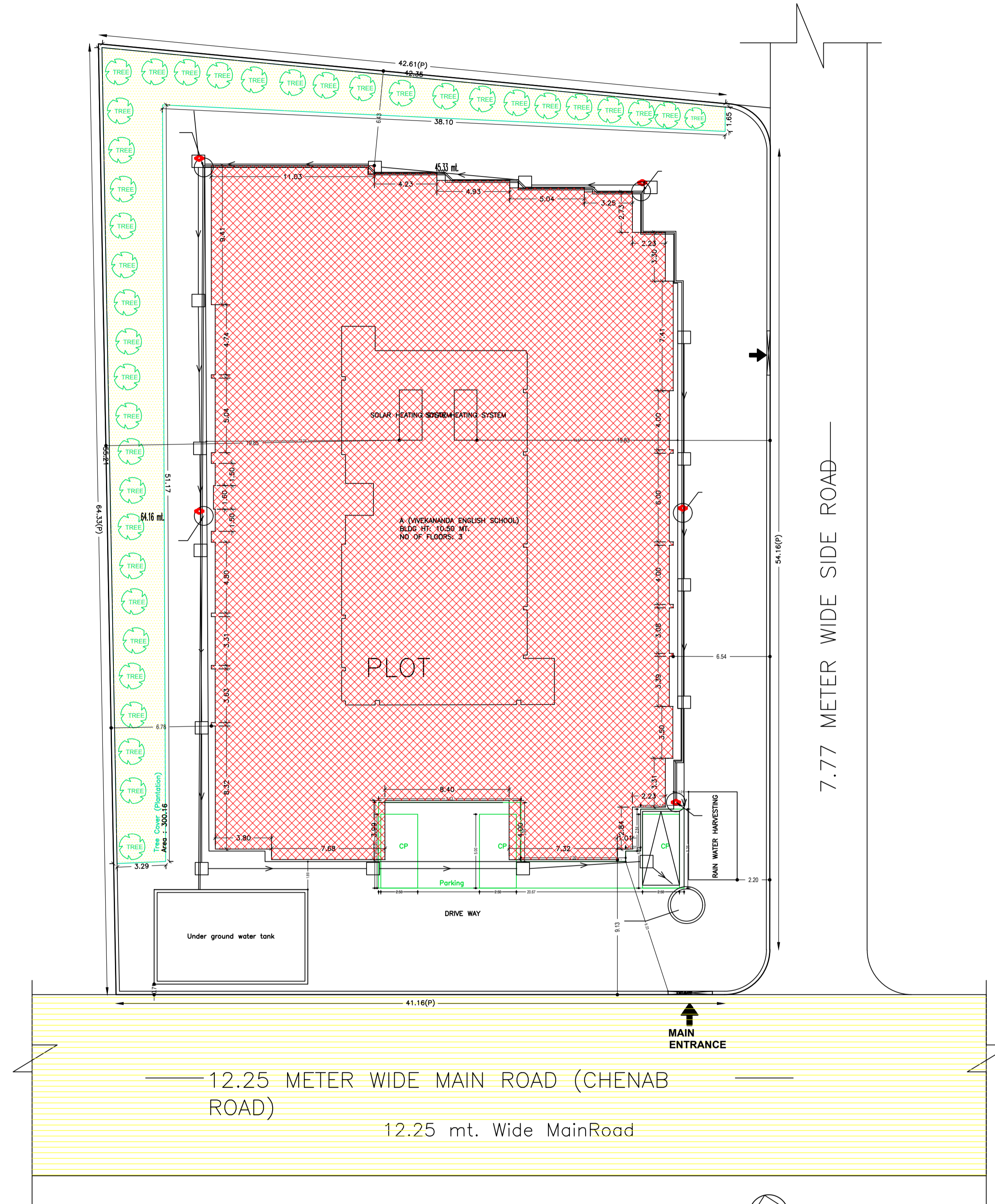

SITE PLAN

SCALE :- 1: 100



SITE PLAN

LTP NAME AND SIGNATURE	STRUCTURAL ENG'S NAME AND SIGNATURE	BUILDER NAME AND SIGNATURE	DIGITAL SIGNATURE
LAWRENCE FRANCIS JNAC/ARC/0003/2016			

Proposal Basic Information	
Proposal File No.	JNAC/BP/0097/W7/2019
Owner Name	RAMAKRISHNA MISSION VIVEKANANDA SOCIETY VIVEKANANDA ENGLISH HIGH SCHOOL
Khata No	245
Plot No	1109
Village Name	SAKCHI
Use	Educational
SubUse	School

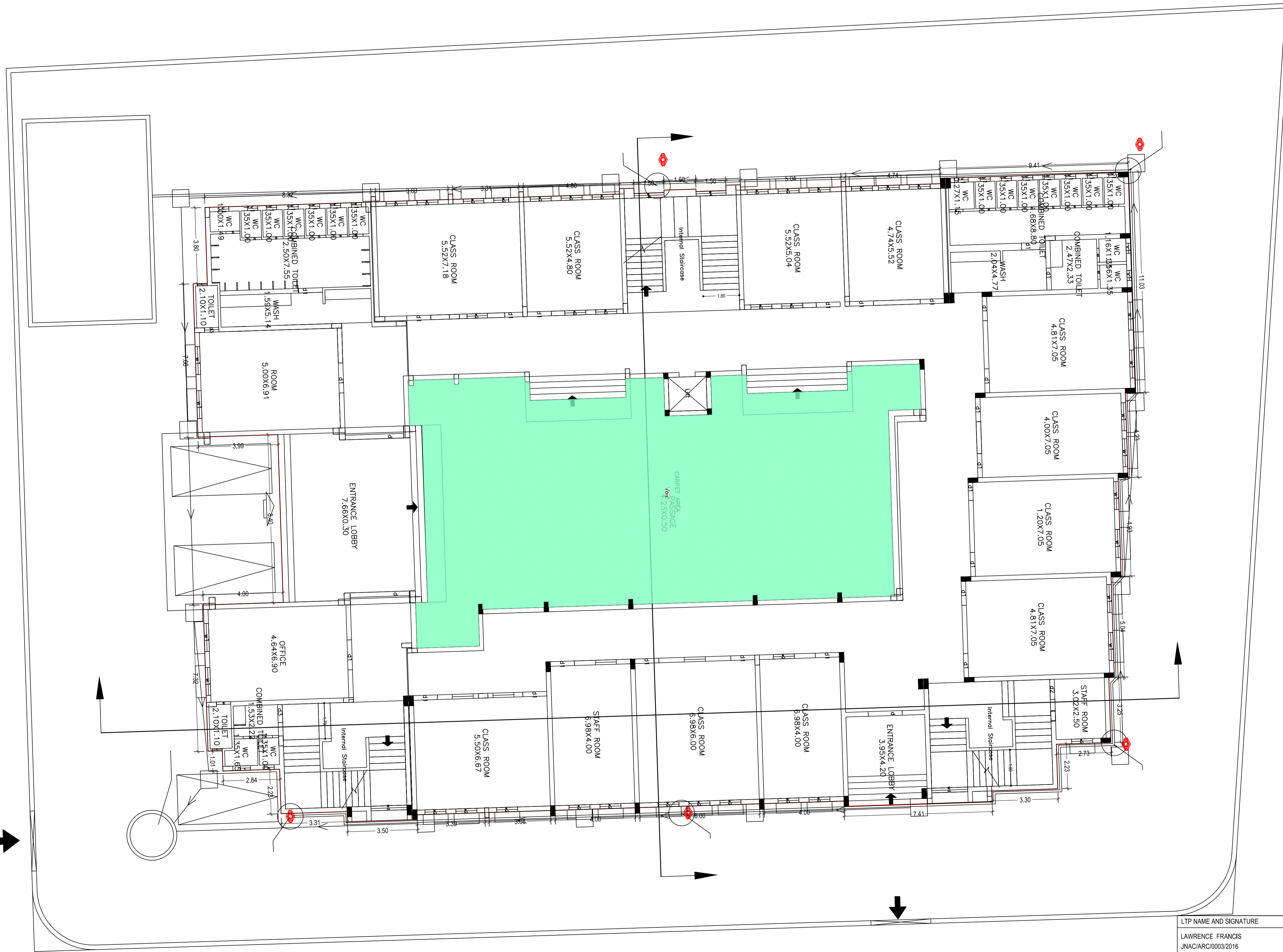

LTP NAME AND SIGNATURE	STRUCTURAL ENG'S NAME AND SIGNATURE	BUILDER NAME AND SIGNATURE	DIGITAL SIGNATURE
LAWRENCE FRANCIS JNAC/ARC/003/2016			

Proposal Basic Information

Proposal File No.	JNAC/BP/0097/W7/2019
Owner Name	RAMAKRISHNA MISSION VIVEKANANDA SOCIETY VIVEKANANDA ENGLISH HIGH SCHOOL
Khata No	245
Plot No	1109
Village Name	SAKCHI
Use	Educational
SubUse	School

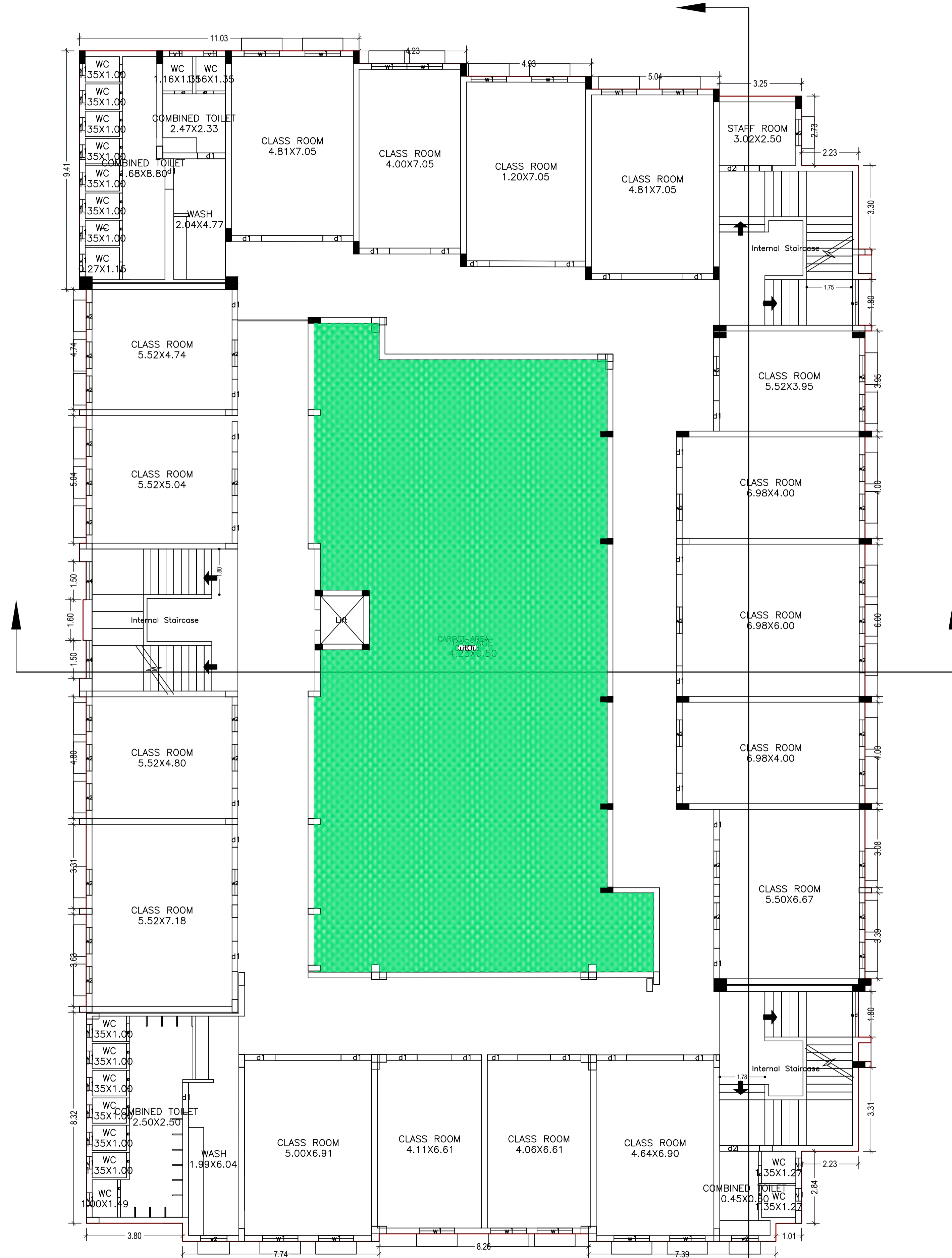

LTP NAME AND SIGNATURE	STRUCTURAL ENG'S NAME AND SIGNATURE	BUILDER NAME AND SIGNATURE	DIGITAL SIGNATURE
LAWRENCE FRANCIS JNAC/ARC/0003/2016			

Proposal Basic Information	
Proposal File No.	JNAC/BP/0097/W7/2019
Owner Name	RAMAKRISHNA MISSION VIVEKANANDA SOCIETY VIVEKANANDA ENGLISH HIGH SCHOOL
Khata No	245
Plot No	1109
Village Name	SAKCHI
Use	Educational
SubUse	School

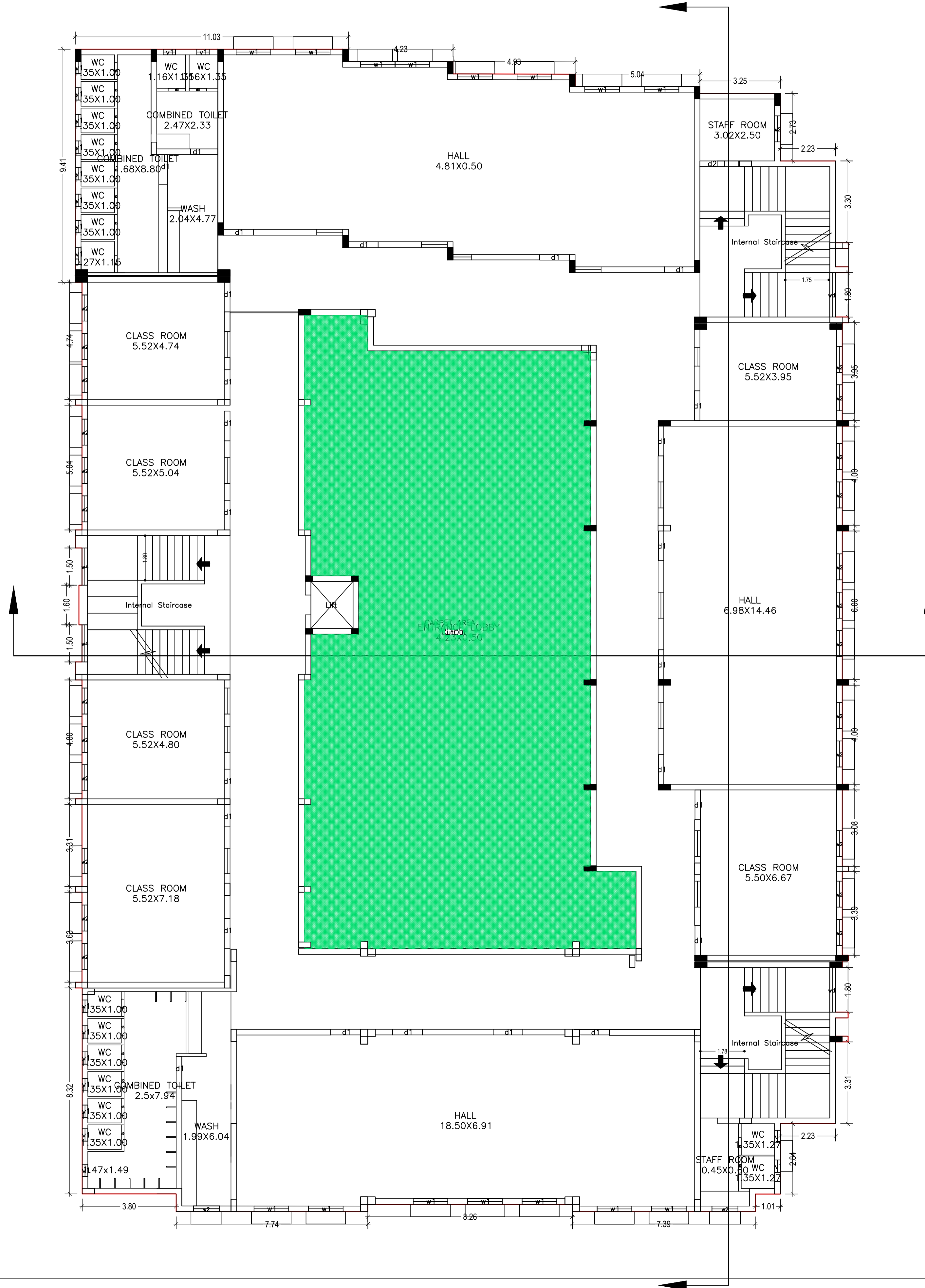

LTP NAME AND SIGNATURE	STRUCTURAL ENG'S NAME AND SIGNATURE	BUILDER NAME AND SIGNATURE	DIGITAL SIGNATURE
LAWRENCE FRANCIS JNAC/ARC/0003/2016			

Proposal Basic Information	
Proposal File No.	JNAC/BP/0097/W7/2019
Owner Name	RAMAKRISHNA MISSION VIVEKANANDA SOCIETY VIVEKANANDA ENGLISH HIGH SCHOOL
Khata No	245
Plot No	1109
Village Name	SAKCHI
Use	Educational
SubUse	School

Building :A (VIVEKANANDA ENGLISH SCHOOL)

Floor Name	Gross Builtup Area	Deductions From Gross BUA(Area in Sq.mt.)		Total Built Up Area (Sq.mt.)	Deductions (Area in Sq.mt.)		Proposed FAR Area (Sq.mt.)	Total FAR Area (Sq.mt.)	Total Consumed Additional FAR Area (Sq.mt.)	Trmt (No.)
		Cutout	Void		Lift	Educational				
Ground Floor	1368.88	0.00		1368.88	0.00	262.55	1106.33	1106.33	1106.33	01
First Floor	1396.29	281.67		1114.62	3.23	0.00	1111.39	1111.39	1111.39	01
Second Floor	1396.29	281.67		1114.62	3.23	0.00	1111.39	1111.39	1111.39	01
Terrace Floor	0.00	0.00		0.00	0.00	0.00	0.00	0.00	0.00	00
Total :	4161.46	563.34		3598.12	6.46	262.55	3329.12	3329.11	3329.11	03
Total Number of Same Buildings	1									
Total :	4161.46	563.34		3598.12	6.46	262.55	3329.12	3329.11	3329.11	03

SCHEDULE OF DOOR:

BUILDING NAME	NAME	LENGTH	HEIGHT	NOS
A (VIVEKANANDA ENGLISH SCHOOL)	d3	0.70	2.10	56
A (VIVEKANANDA ENGLISH SCHOOL)	d2	0.70	2.10	01
A (VIVEKANANDA ENGLISH SCHOOL)	d3	0.72	2.10	02
A (VIVEKANANDA ENGLISH SCHOOL)	d1	0.90	2.10	05
A (VIVEKANANDA ENGLISH SCHOOL)	d3	0.90	2.10	01
A (VIVEKANANDA ENGLISH SCHOOL)	d2	1.00	2.10	03
A (VIVEKANANDA ENGLISH SCHOOL)	d1	1.10	2.10	03
A (VIVEKANANDA ENGLISH SCHOOL)	d1	1.20	2.10	73
A (VIVEKANANDA ENGLISH SCHOOL)	d1	1.50	2.10	02
A (VIVEKANANDA ENGLISH SCHOOL)	d	1.70	2.10	01
A (VIVEKANANDA ENGLISH SCHOOL)	d	2.93	2.10	01
A (VIVEKANANDA ENGLISH SCHOOL)	d	2.96	2.10	01

SCHEDULE OF WINDOW/VENTILATION:

BUILDING NAME	NAME	LENGTH	HEIGHT	NOS
A (VIVEKANANDA ENGLISH SCHOOL)	v1	0.48	0.60	01
A (VIVEKANANDA ENGLISH SCHOOL)	v1	0.50	0.60	56
A (VIVEKANANDA ENGLISH SCHOOL)	v1	0.68	0.60	02
A (VIVEKANANDA ENGLISH SCHOOL)	w2	0.75	1.20	02
A (VIVEKANANDA ENGLISH SCHOOL)	w2	1.03	1.20	05
A (VIVEKANANDA ENGLISH SCHOOL)	w2	1.05	1.20	88
A (VIVEKANANDA ENGLISH SCHOOL)	w1	1.40	1.20	42
A (VIVEKANANDA ENGLISH SCHOOL)	w4	1.50	1.20	06
A (VIVEKANANDA ENGLISH SCHOOL)	wd	1.80	1.20	06

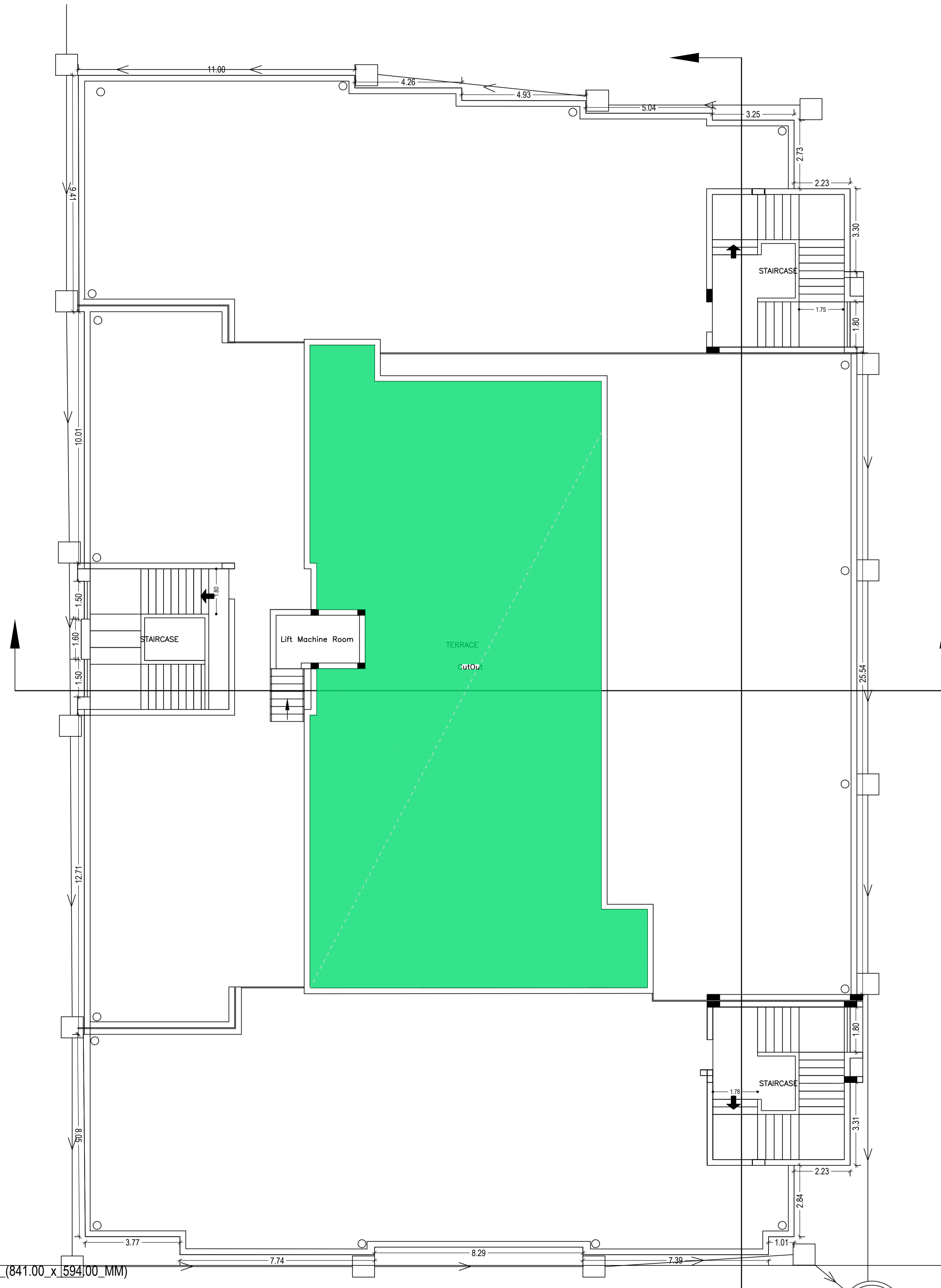

LTP NAME AND SIGNATURE	STRUCTURAL ENG'S NAME AND SIGNATURE	BUILDER NAME AND SIGNATURE	DIGITAL SIGNATURE
LAWRENCE FRANCIS JNAC/ARC/0003/2016			

Proposal Basic Information	
Proposal File No.	JNAC/BP/0097/W7/2019
Owner Name	RAMAKRISHNA MISSION VIVEKANANDA SOCIETY VIVEKANANDA ENGLISH HIGH SCHOOL
Khata No	245
Plot No	1109
Village Name	SAKCHI
Use	Educational
SubUse	School

UnitBUA Table for Building :A (VIVEKANANDA ENGLISH SCHOOL)

FLOOR	Name	UnitBUA Type	UnitBUA Area	Carpet Area	No. of Rooms	No. of Tenement
GROUND FLOOR PLAN	CARPET AREA	OTHER	1061.11	1060.74	45	1
FIRST FLOOR PLAN	CARPET AREA	OTHER	1073.79	1073.23	44	1
SECOND FLOOR PLAN	CARPET AREA	OTHER	1073.82	1073.12	35	1
Total:	-	-	3208.72	3207.09	124	3

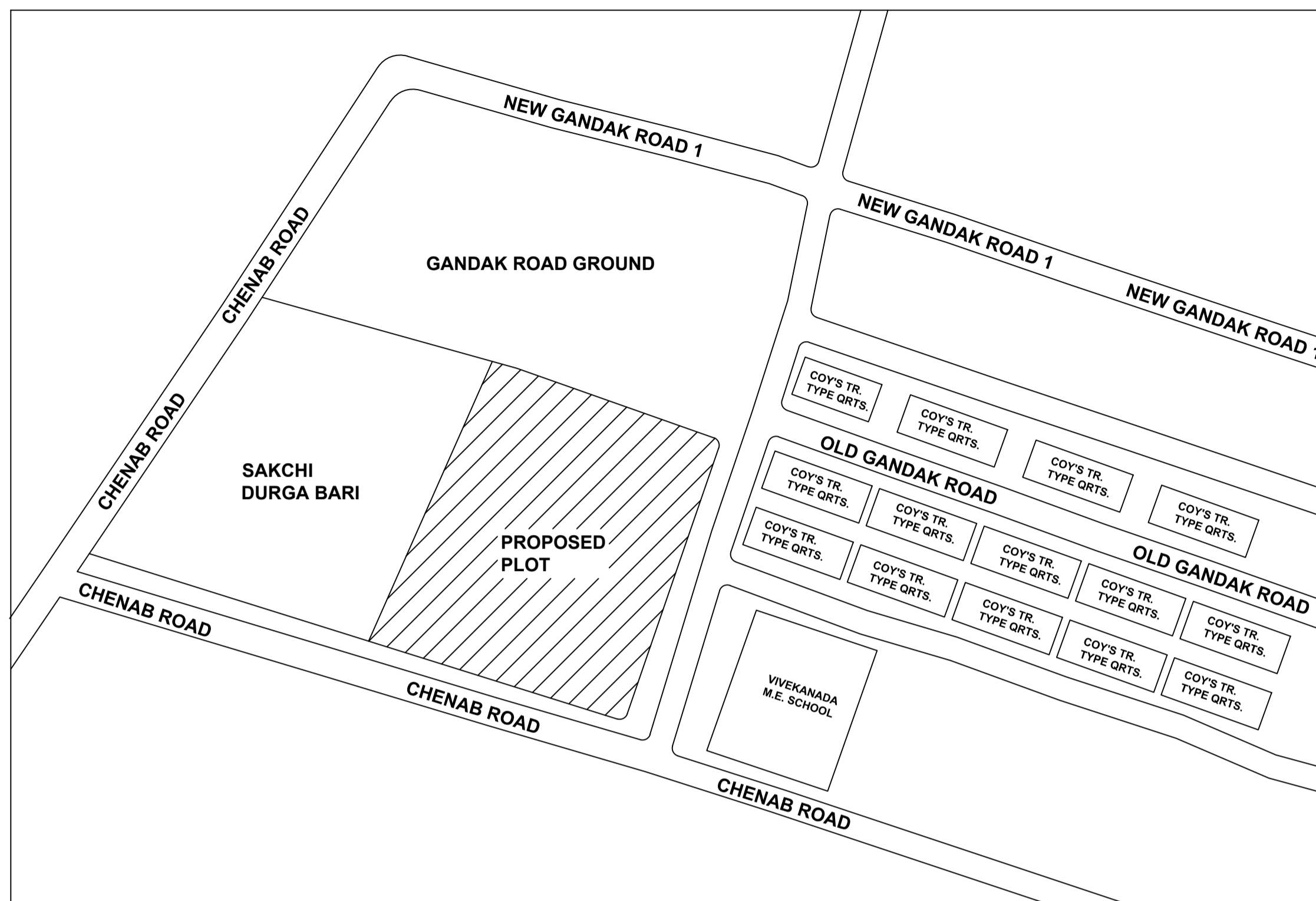

LOCATION MAP
SCALE :- N.T.S

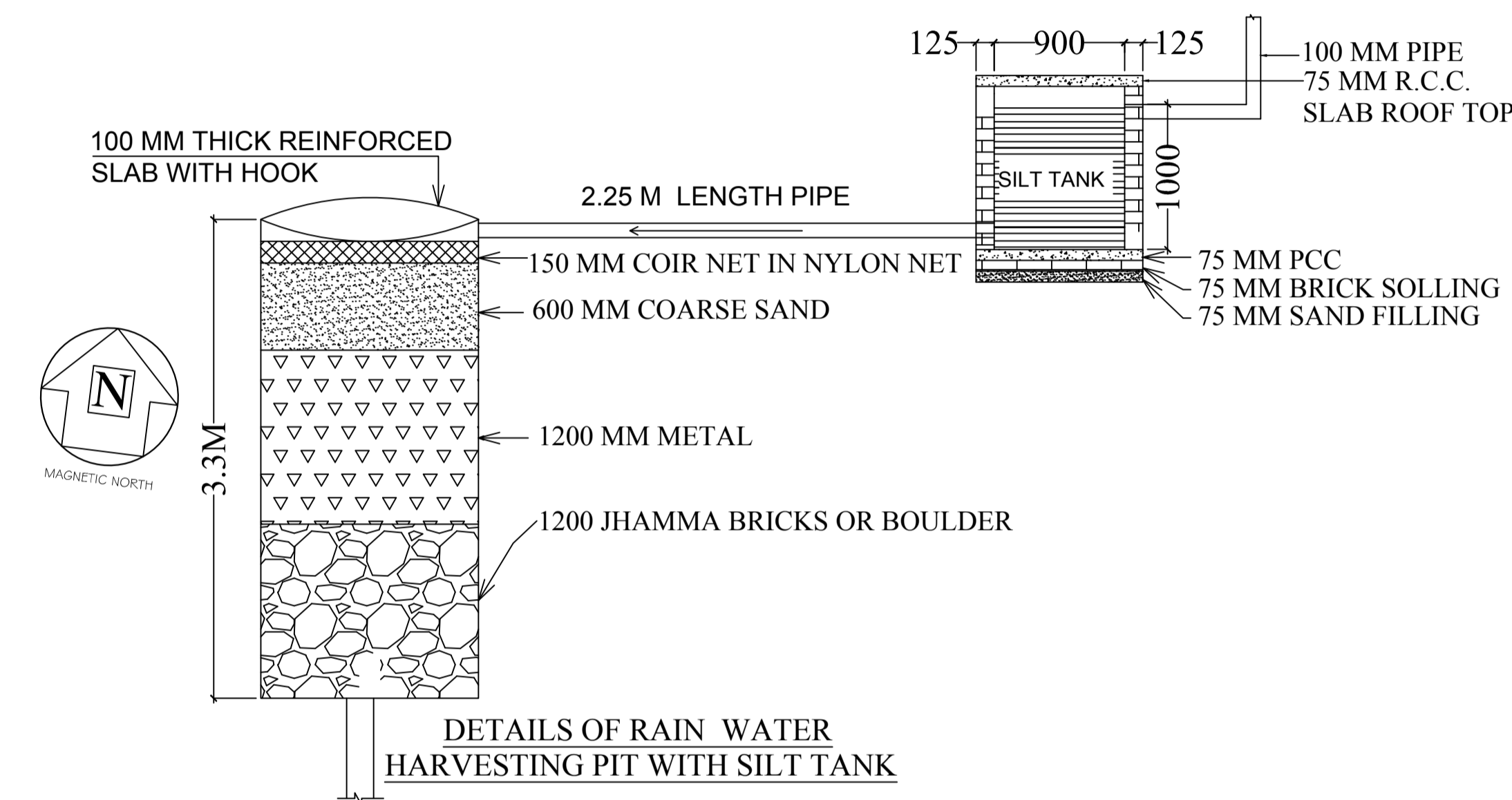

TYPICAL SECTION OF BEAM

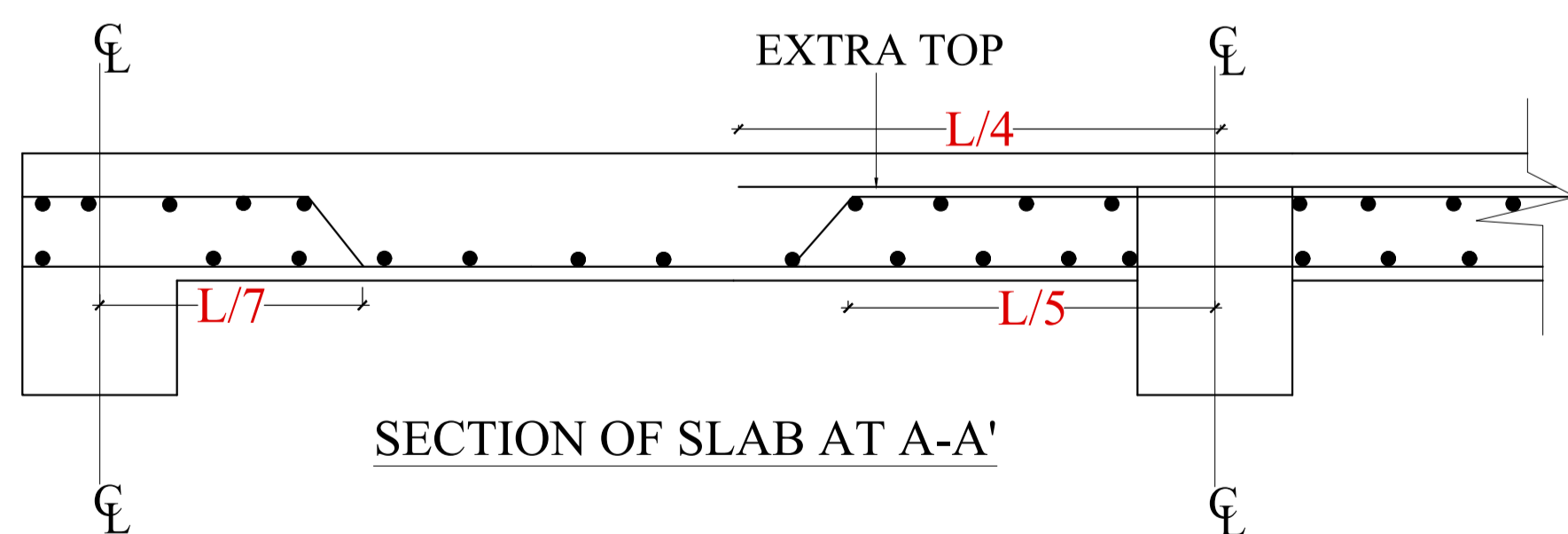

SECTION OF SLAB AT A-A'

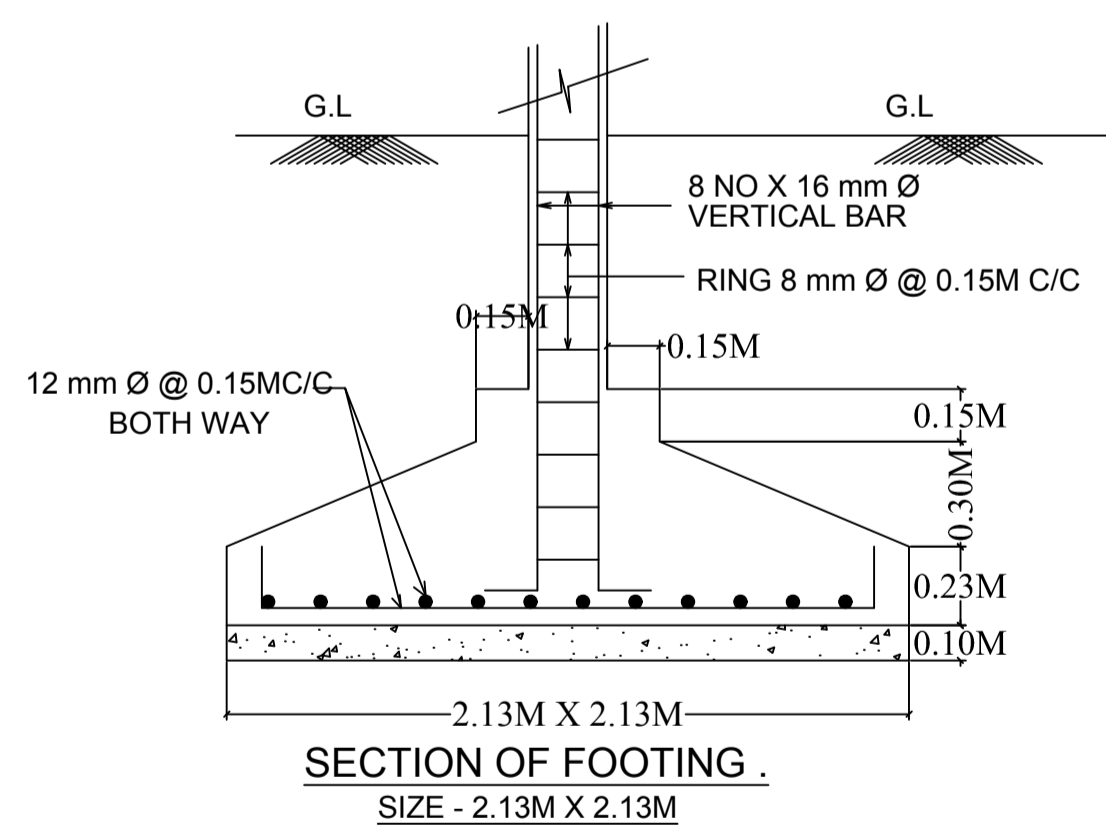

SECTION OF FOOTING
SIZE - 2.13M X 2.13M

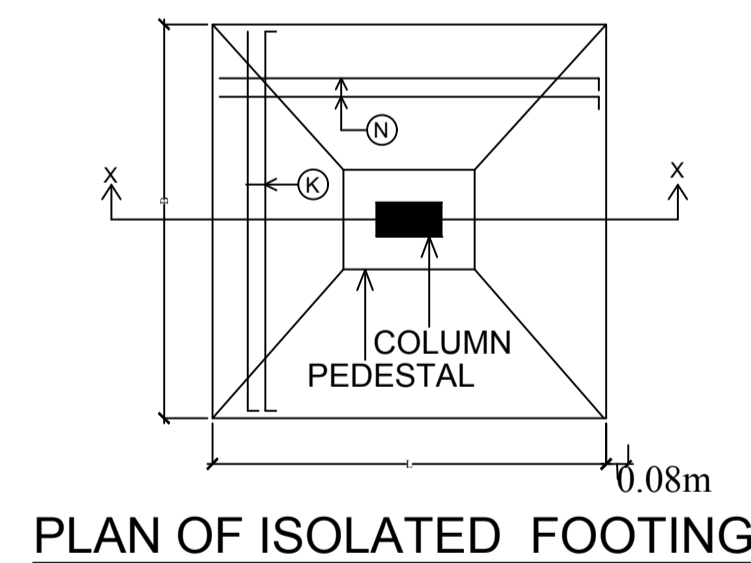

PLAN OF ISOLATED FOOTING

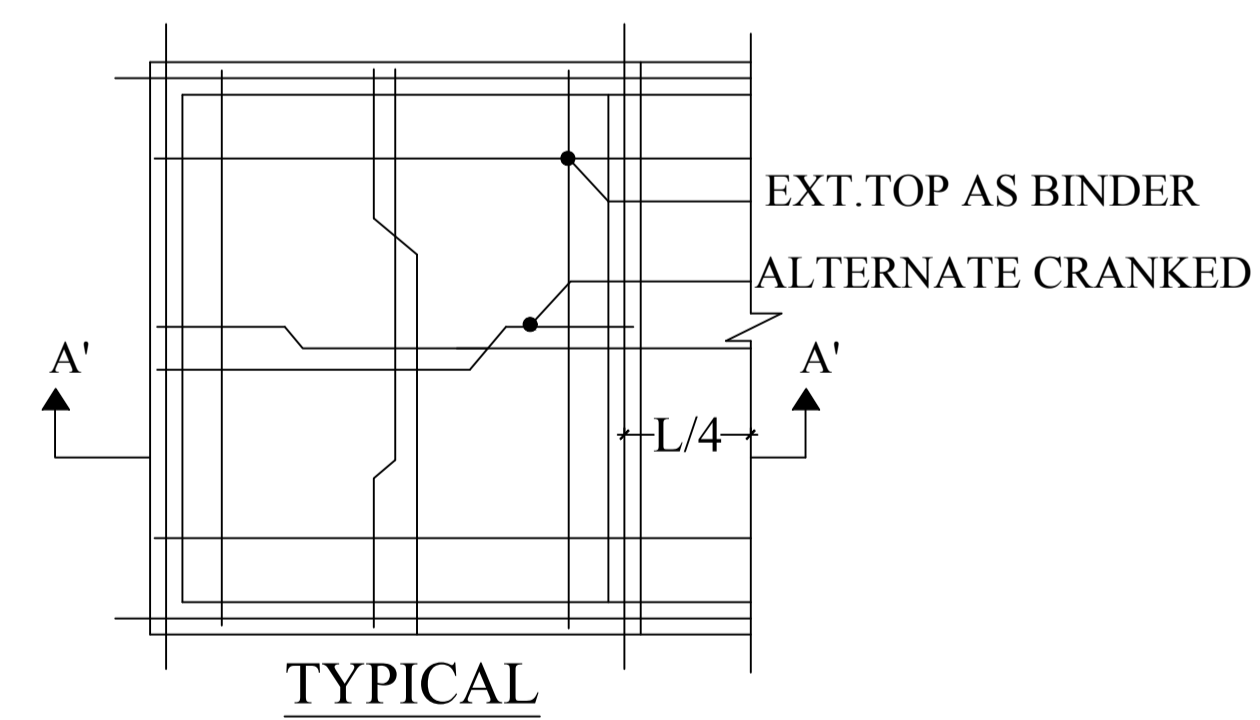

TYPICAL

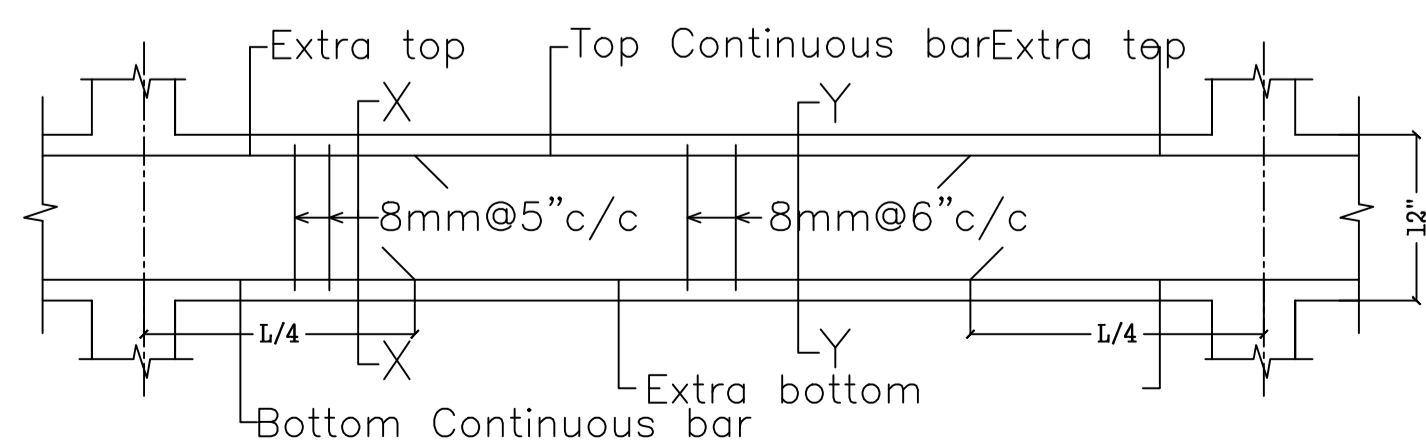

LTP NAME AND SIGNATURE	STRUCTURAL ENG'S NAME AND SIGNATURE	BUILDER NAME AND SIGNATURE	DIGITAL SIGNATURE
LAWRENCE FRANCIS JNACIARC/003/2016			

Proposal Basic Information	
Proposal File No.	JNAC/BP/0097/W7/2019
Owner Name	RAMAKRISHNA MISSION VIVEKANANDA SOCIETY VIVEKANANDA ENGLISH HIGH SCHOOL
Khata No	245
Plot No	1109
Village Name	SAKCHI
Use	Educational
SubUse	School

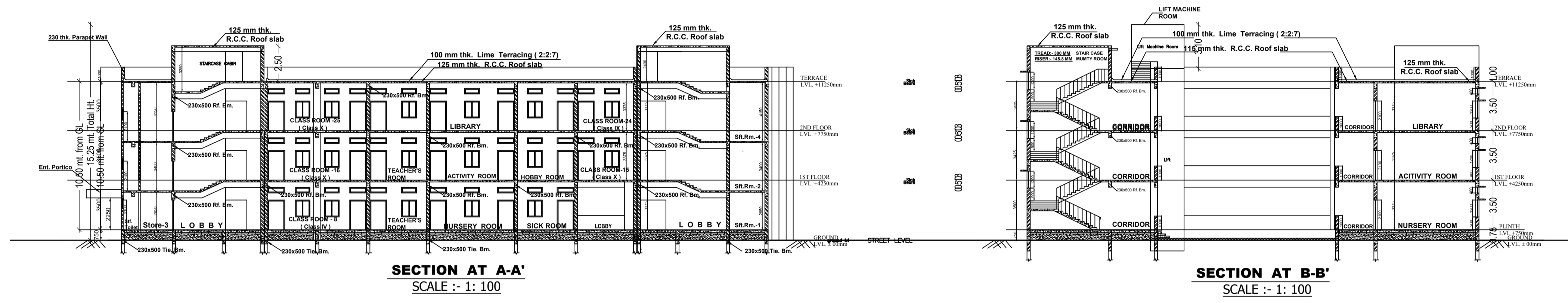

LTP NAME AND SIGNATURE	STRUCTURAL ENG'S NAME AND SIGNATURE	BUILDER NAME AND SIGNATURE	DIGITAL SIGNATURE
LAWRENCE FRANCIS JNAC/ARC/0003/2016			

Proposal Basic Information	
Proposal File No.	JNAC/BP/0097/W7/2019
Owner Name	RAMAKRISHNA MISSION VIVEKANANDA SOCIETY VIVEKANANDA ENGLISH HIGH SCHOOL
Khata No	245
Plot No	1109
Village Name	SAKCHI
Use	Educational
SubUse	School



SIDE ELEVATION
(EASTERN SIDE)
 SCALE :- 1: 100

LTP NAME AND SIGNATURE	STRUCTURAL ENG'S NAME AND SIGNATURE	BUILDER NAME AND SIGNATURE	DIGITAL SIGNATURE
LAWRENCE FRANCIS JNAC/ARC/0003/2016			

Proposal Basic Information	
Proposal File No.	JNAC/BP/0097/W7/2019
Owner Name	RAMAKRISHNA MISSION VIVEKANANDA SOCIETY VIVEKANANDA ENGLISH HIGH SCHOOL
Khata No	245
Plot No	1109
Village Name	SAKCHI
Use	Educational
SubUse	School

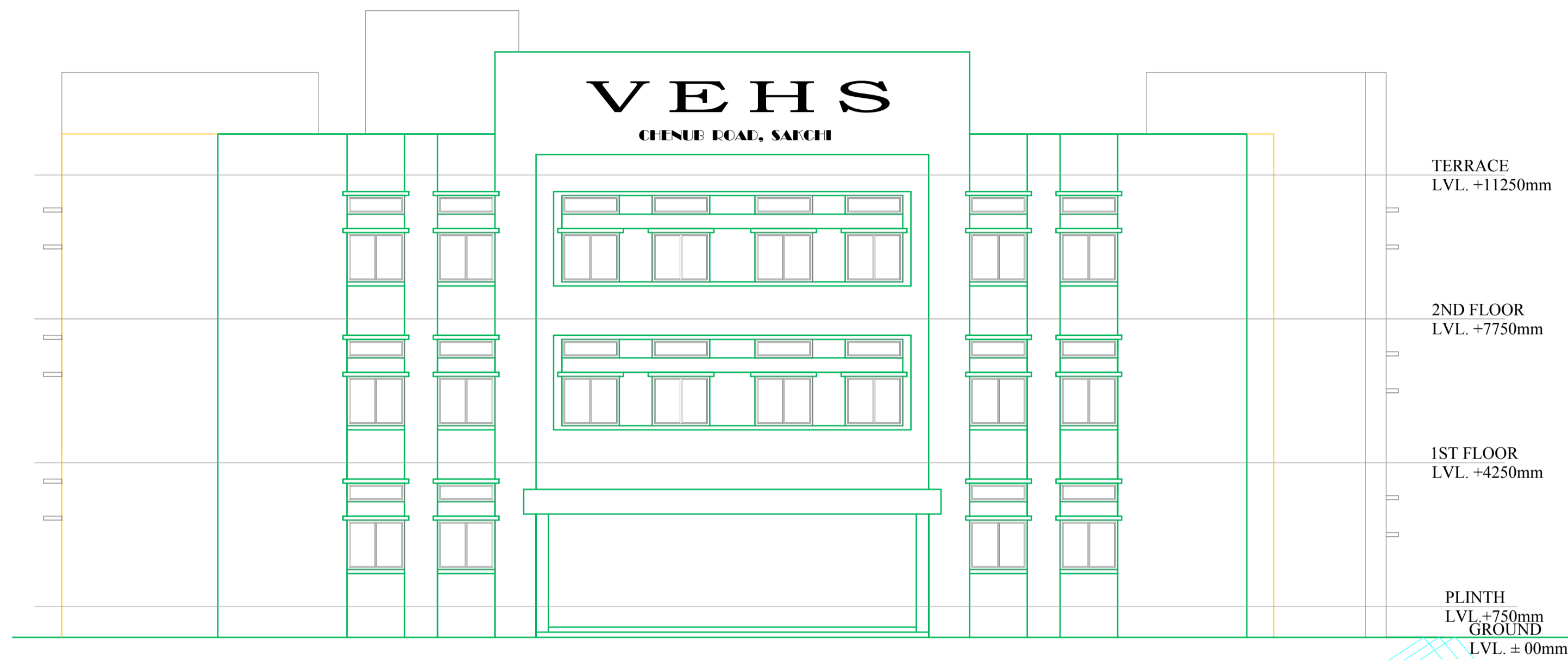

FRONT ELEVATION
(SOUTHERN SIDE)
SCALE :- 1: 100

LTP NAME AND SIGNATURE	STRUCTURAL ENG'S NAME AND SIGNATURE	BUILDER NAME AND SIGNATURE	DIGITAL SIGNATURE
LAWRENCE FRANCIS JNAC/ARC/0003/2016			