

Project Title : MR AKASH MODI

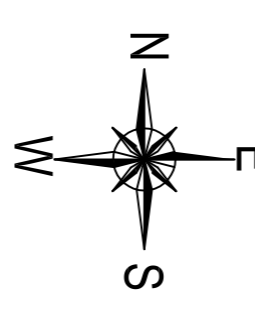
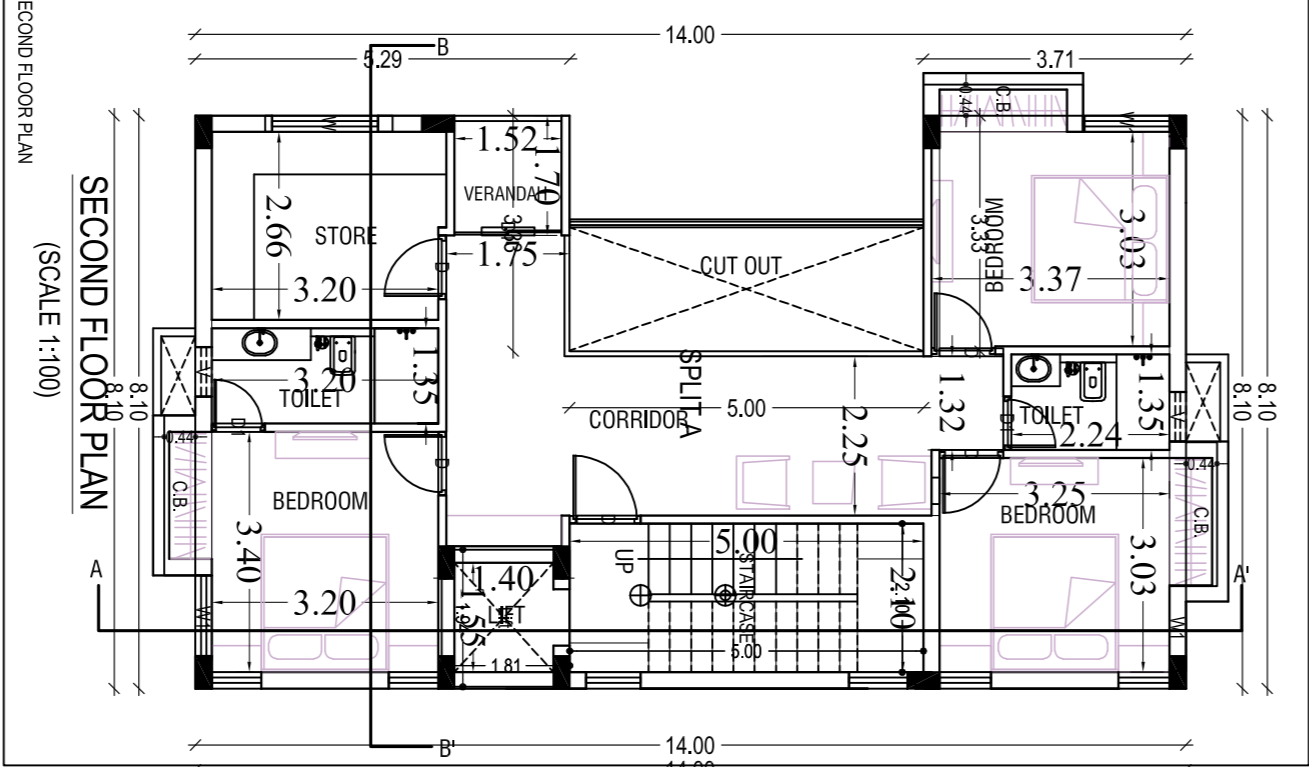
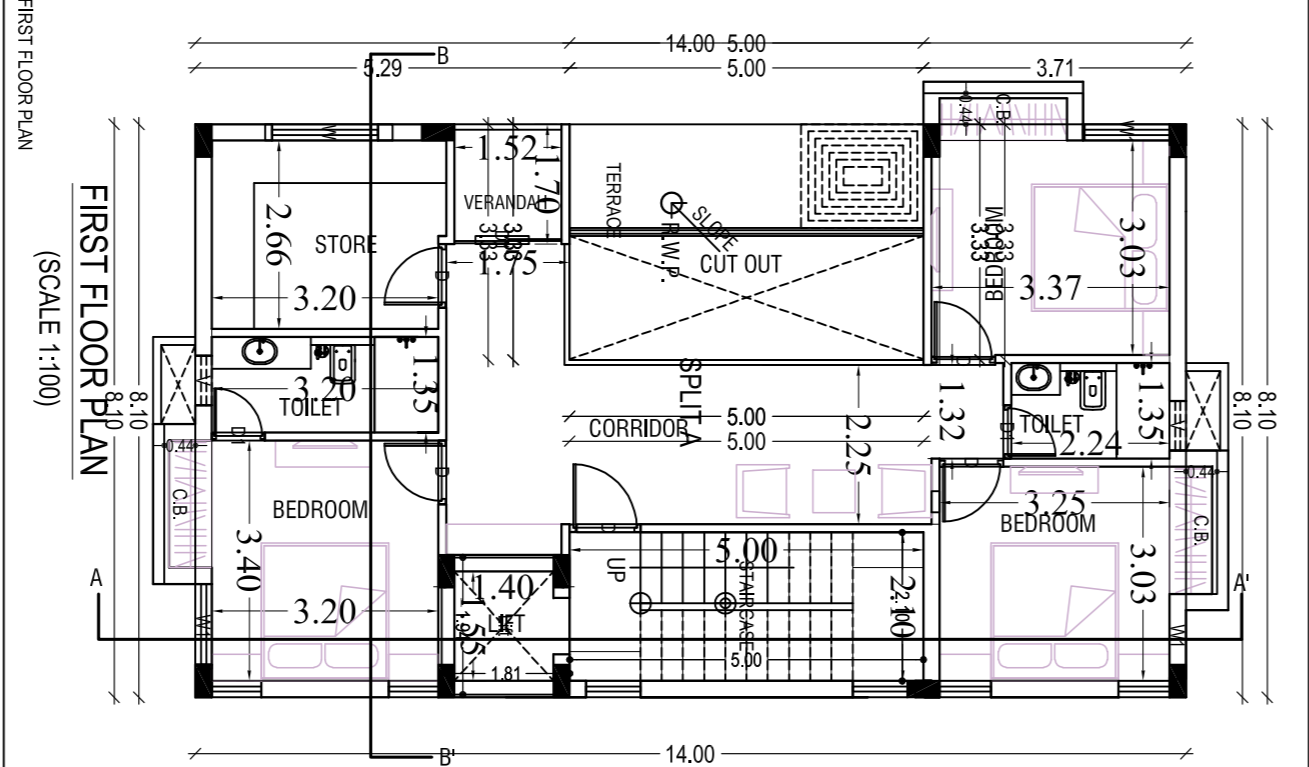
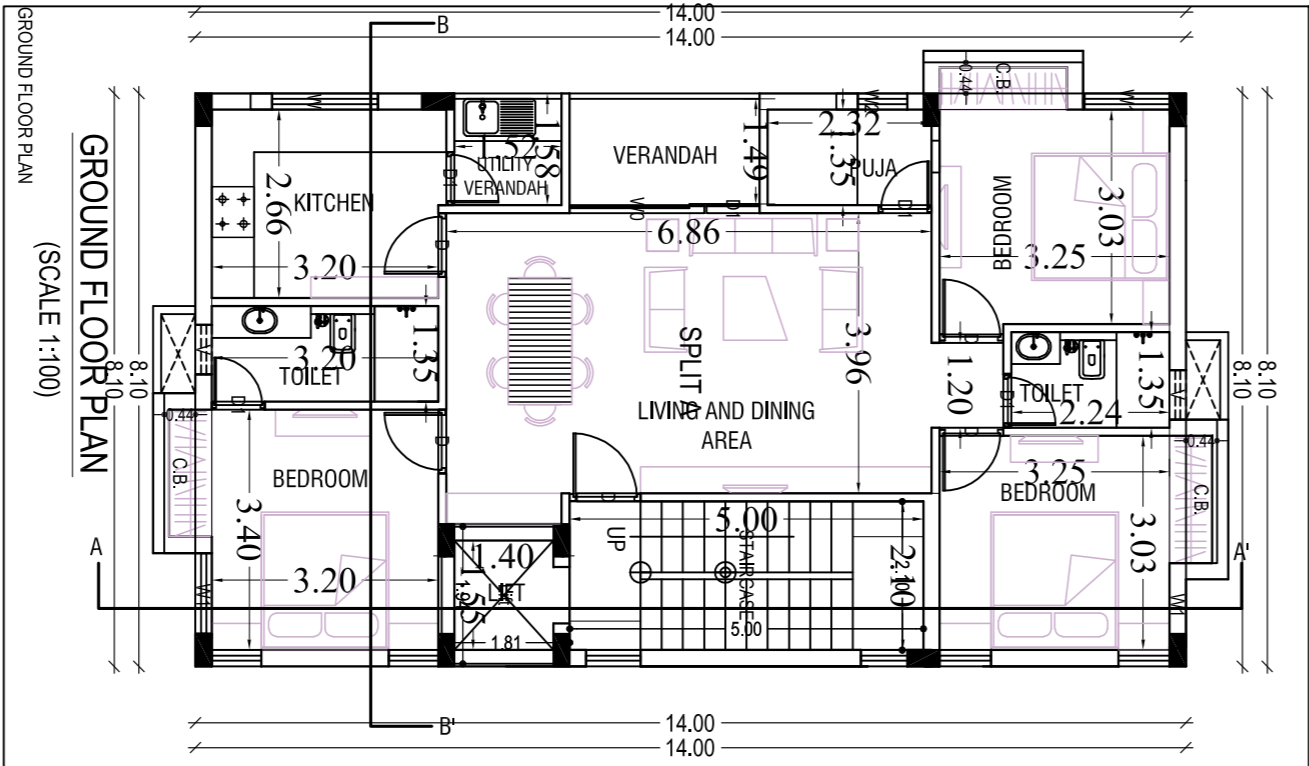
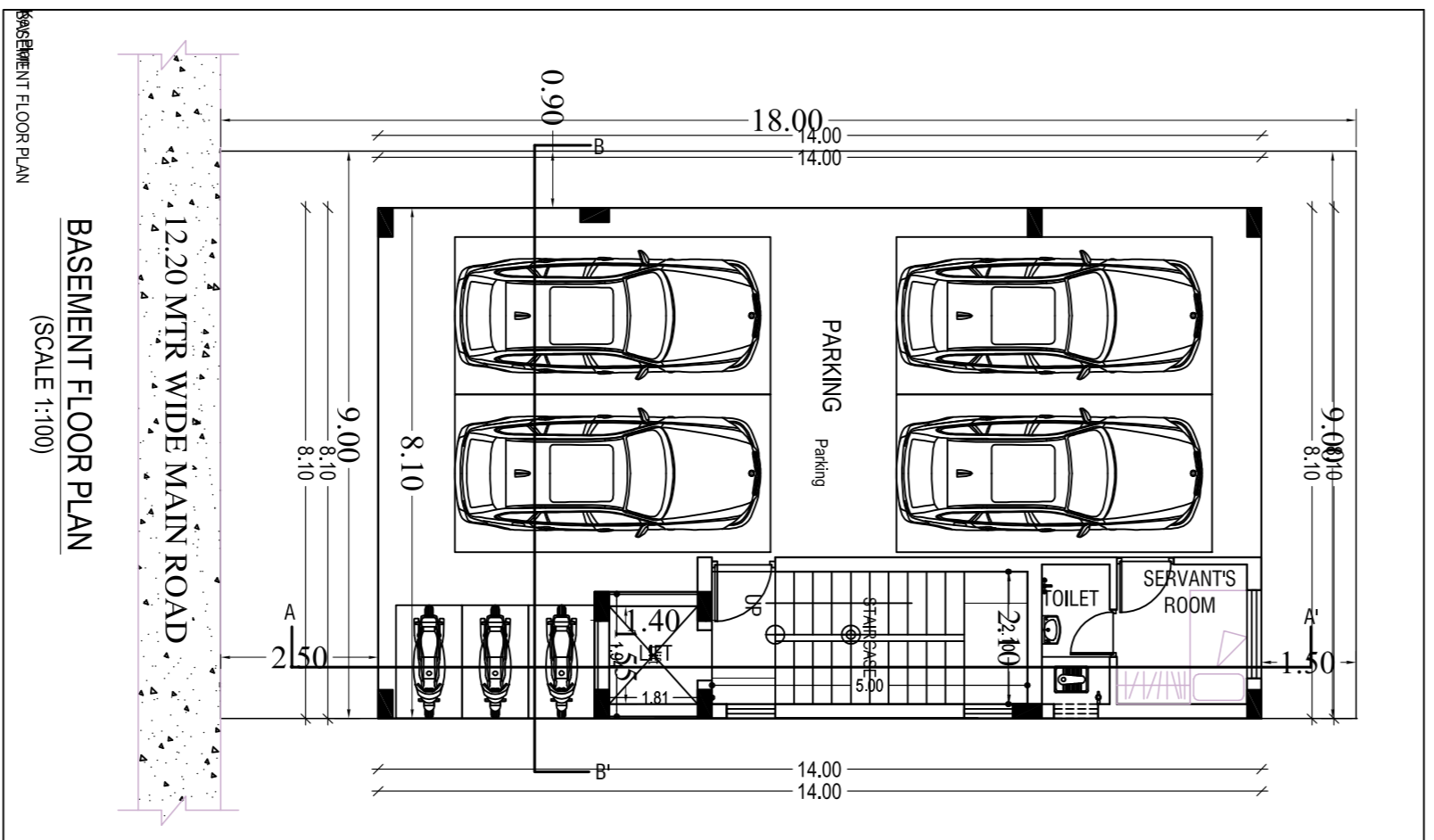
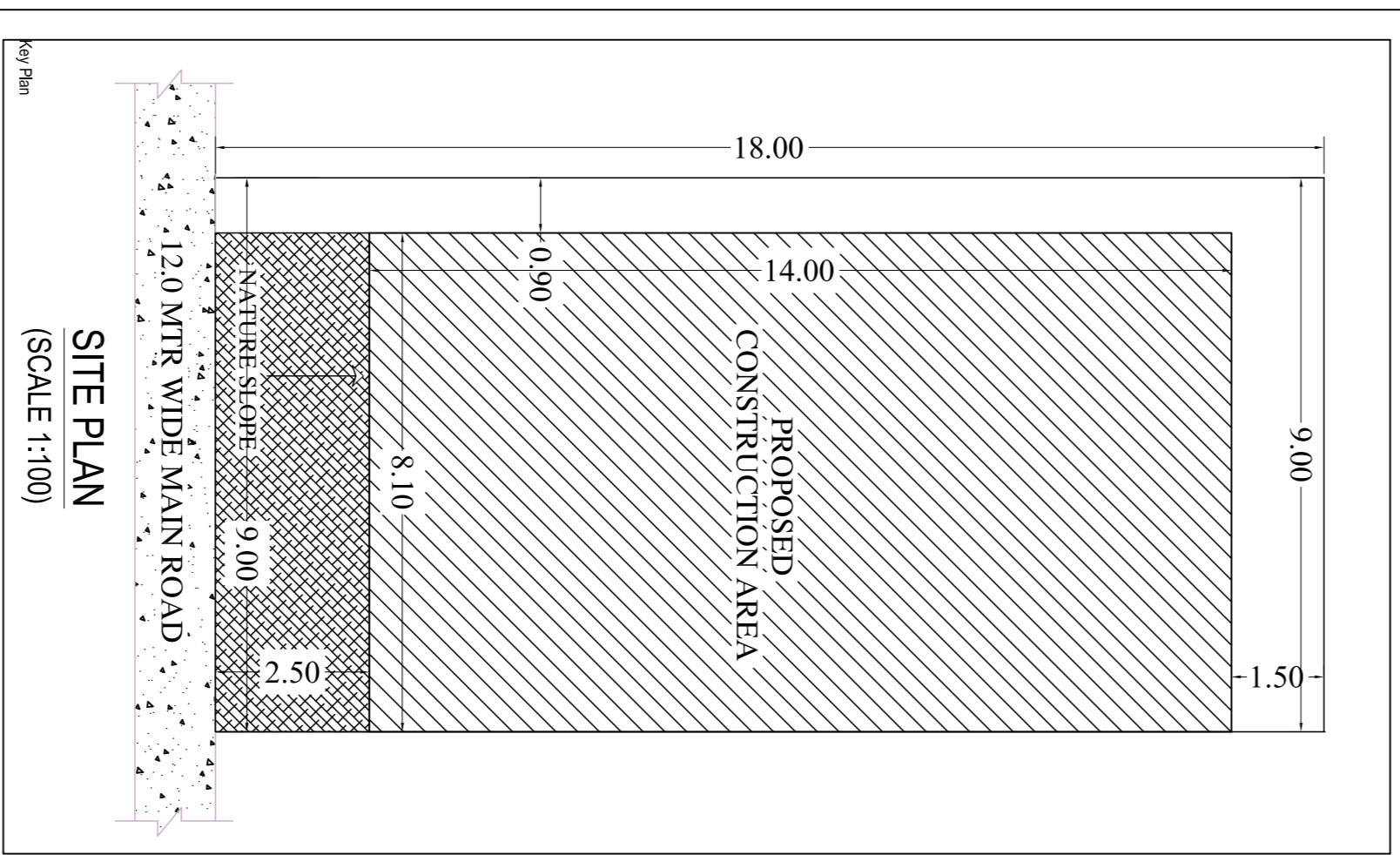
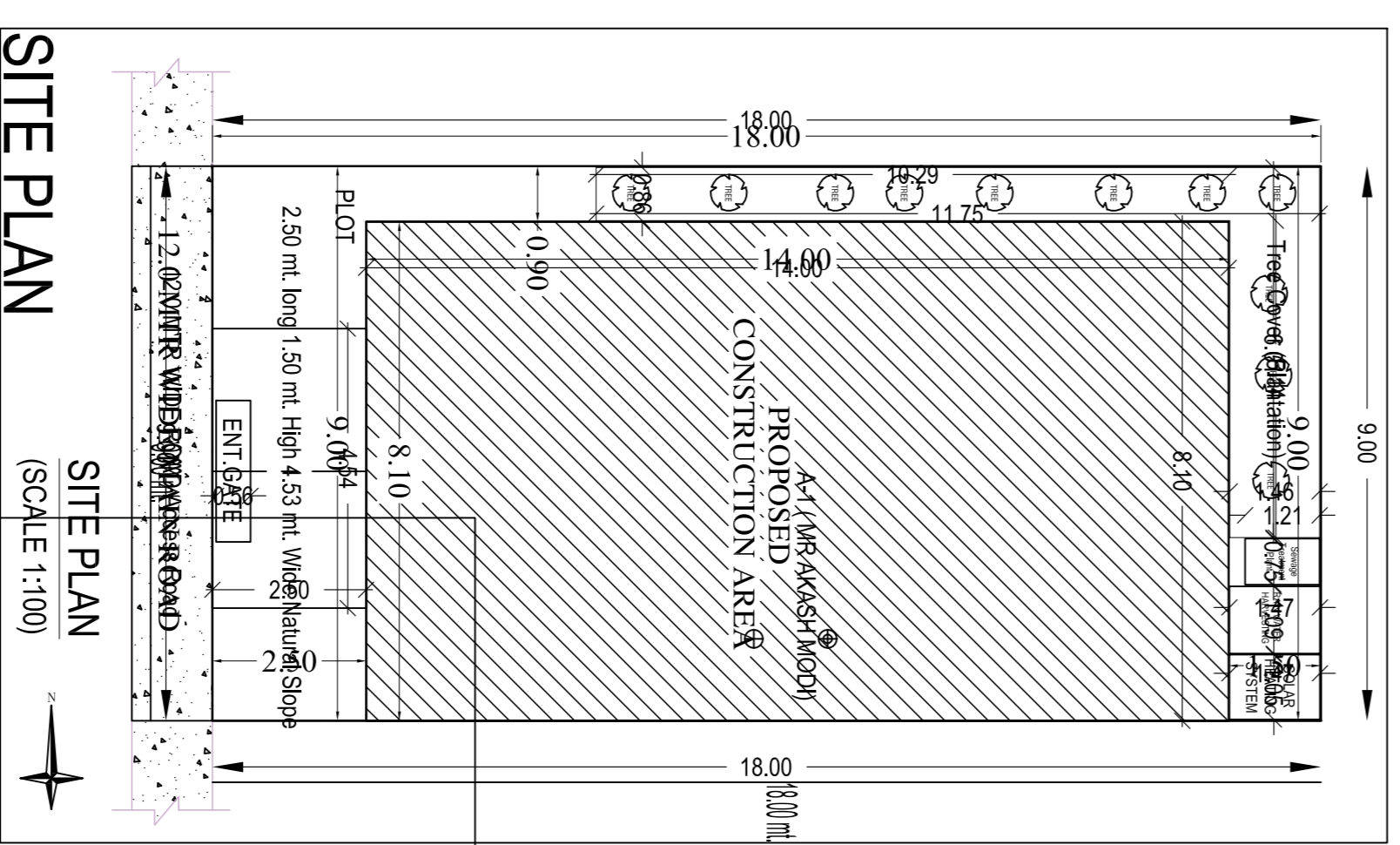
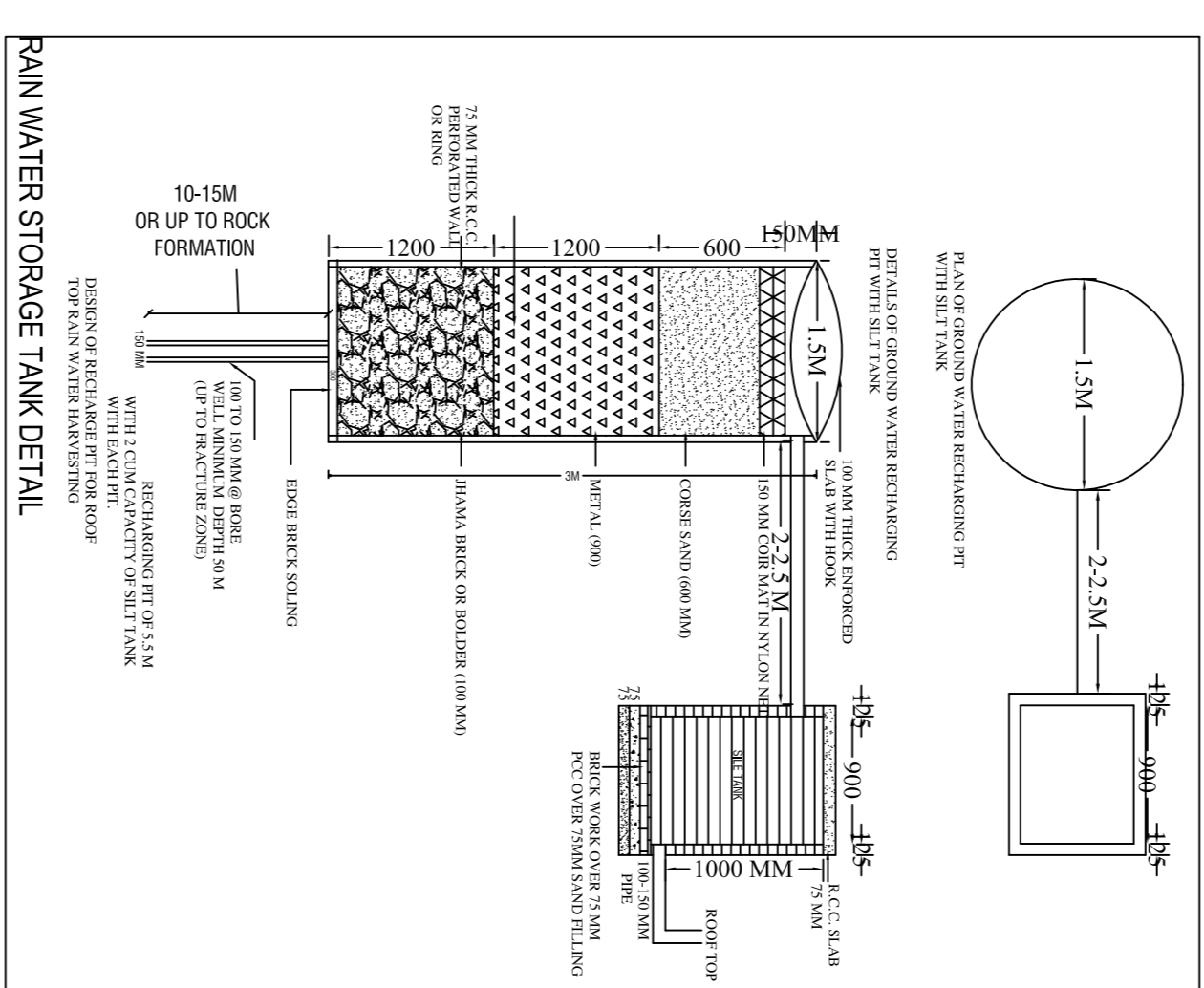
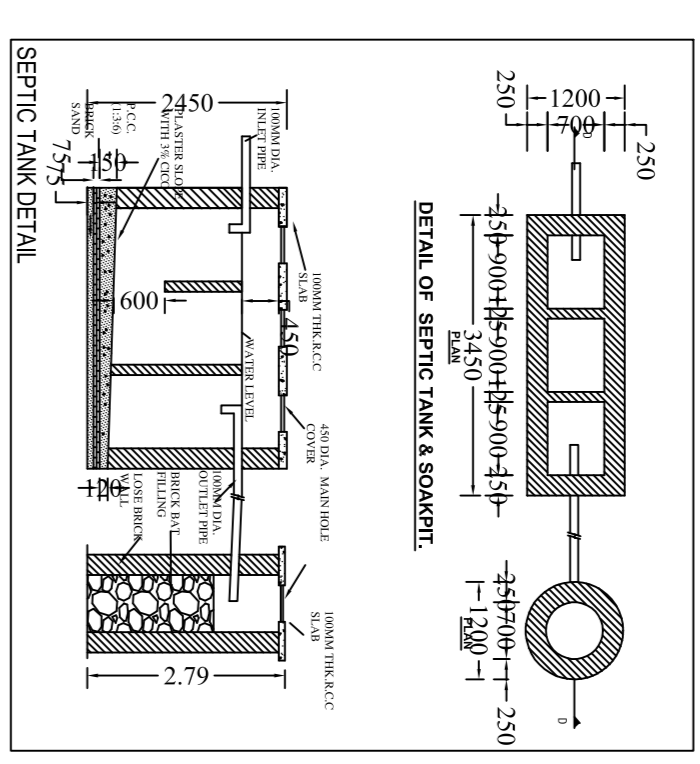
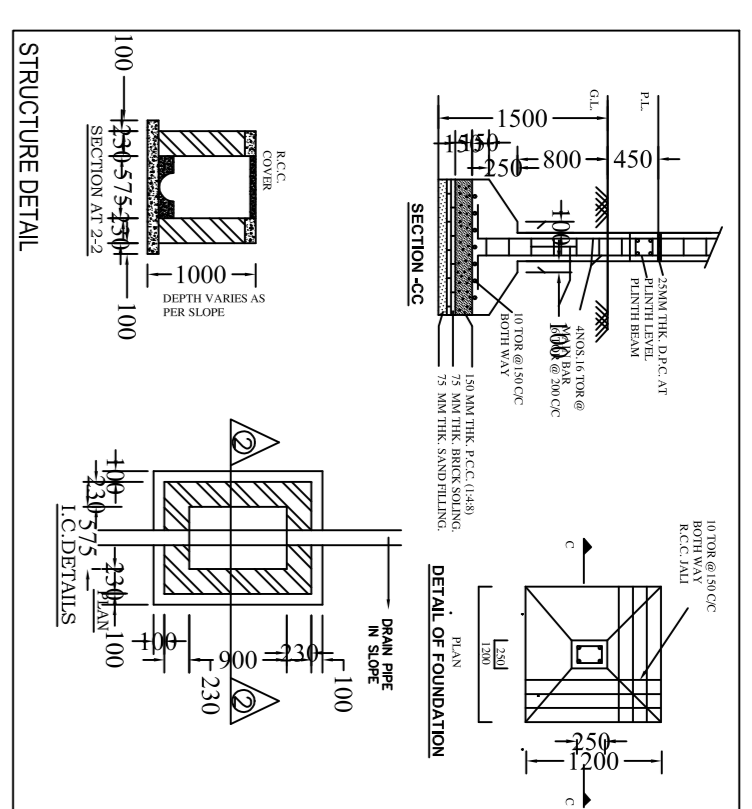
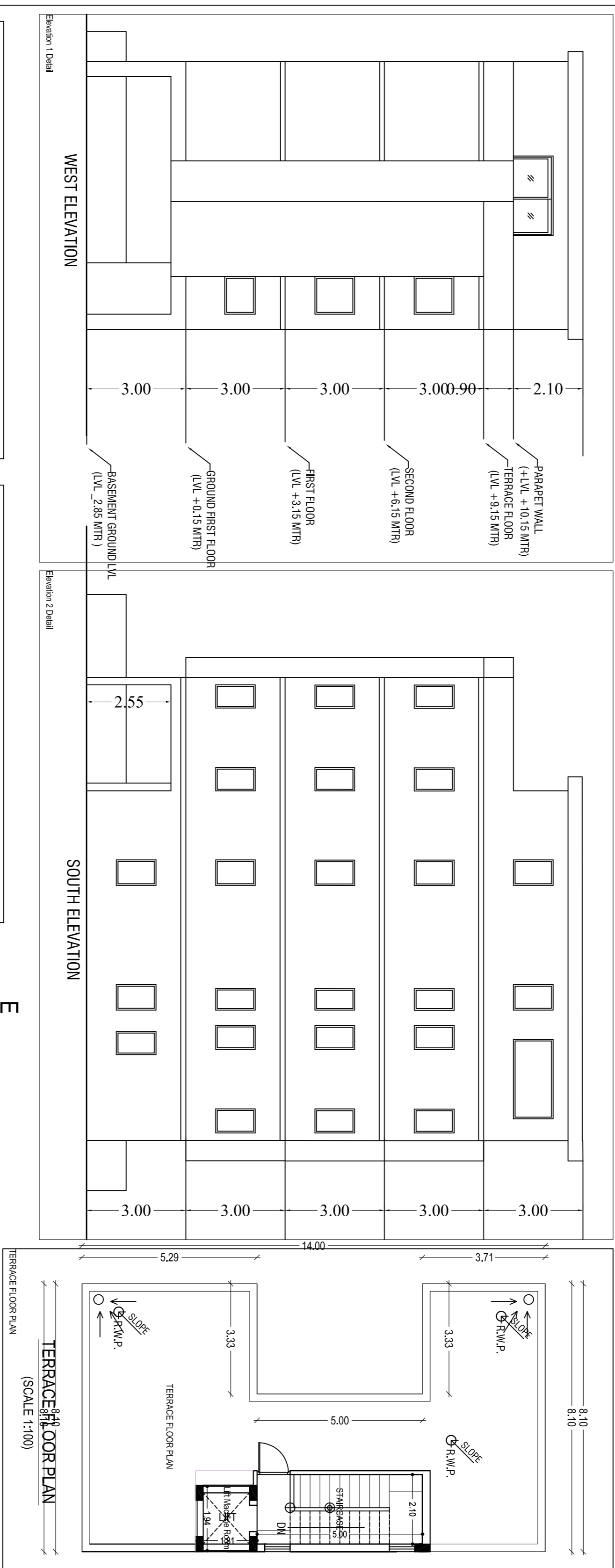
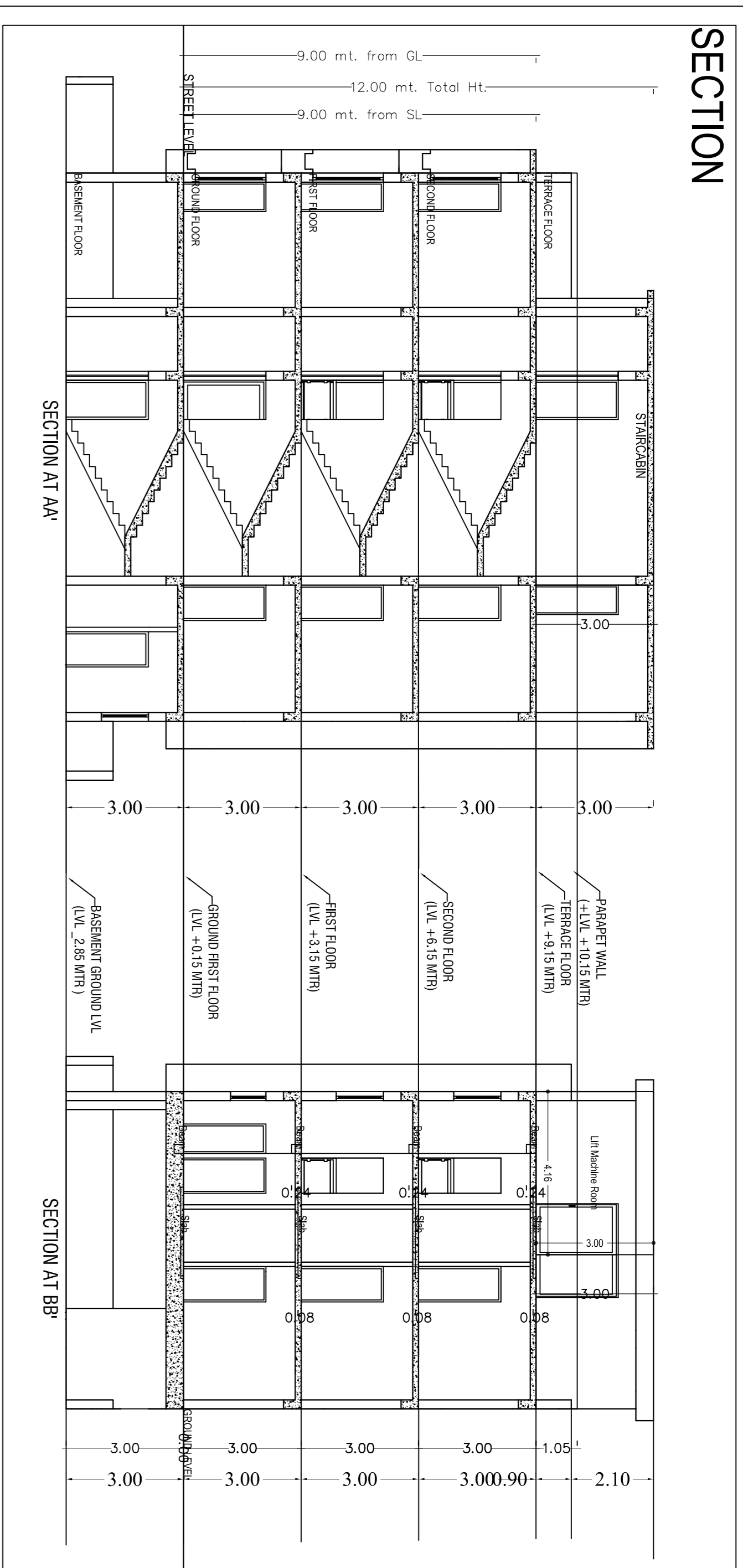

LAND DETAILS
 PROPOSED RESIDENTIAL BUILDING PLAN OF
MR AKASH MODI
 S/O. MR BASUDEV MODI
 PLOT NO. - 947
 KHATA NO. - 622
 MOUZA - SONARI JAMSHEDPUR
 WARD NO. - 6, THANA NO. - 1156
 DISTRICT - EAST SINGHBHUM
 STATE -- JHARKHAND.

Applicant's Signature: SIGNATURE OF I.C. ENGINEER

Building - A (MR AKASH MODI)

Area Name	Total Area (sq. Mtr.)	Proposed Area (sq. Mtr.)	Setback Area (sq. Mtr.)	Total Area (sq. Mtr.)
Plot Area	162.00	162.00	162.00	162.00
Proposed Area	114.84	114.84	114.84	114.84
Setback Area	47.16	47.16	47.16	47.16
Plot Area	162.00	162.00	162.00	162.00

SCHEDULE OF JOINTS

Joint No.	Location	Length (mtr.)	Height (mtr.)	Notes
1	At the top of the wall	0.00	2.13	15
2	At the bottom of the wall	0.00	0.00	28

UNIT DATA

Material	Unit	Quantity	Rate	Total
Concrete	m ³	1.20	2700	3240
Brick	nos	1200	100	120000
Plaster	m ²	1200	100	120000
Paint	liters	1200	100	120000

UNIT DATA

Material	Unit	Quantity	Rate	Total
Concrete	m ³	1.20	2700	3240
Brick	nos	1200	100	120000
Plaster	m ²	1200	100	120000
Paint	liters	1200	100	120000

STATEMENT OF WORKS

Sl. No.	Description	Quantity	Rate	Amount
1	Excavation for foundation	100	100	10000
2	Foundation concrete	100	200	20000
3	Foundation brickwork	100	100	10000
4	Foundation plaster	100	100	10000
5	Foundation paint	100	100	10000
6	Foundation formwork	100	100	10000
7	Foundation reinforcement	100	100	10000
8	Foundation curing	100	100	10000
9	Foundation inspection	100	100	10000
10	Foundation completion	100	100	10000

PARKING CALCULATION

Category	Area (sq. mtr.)	Capacity
Car	100	10
Two Wheeler	100	10
Auto Rickshaw	100	10
Motor Cycle	100	10
Tricycle	100	10
Other	100	10

MARGIN DETAIL

Margin Type	Front Margin	Side Margin	Back Margin
Minimum	2.00	1.50	0.50
Maximum	2.00	1.50	0.50

PRESENT MARGIN DETAIL

Margin Type	Front Margin	Side Margin	Back Margin
Minimum	2.00	1.50	0.50
Maximum	2.00	1.50	0.50

PLAN & Treatment Details (Table 46-1)

Sl. No.	Area	Material	Quantity	Rate	Amount
1	100	Concrete	100	200	20000
2	100	Brick	1000	100	100000
3	100	Plaster	1000	100	100000
4	100	Paint	1000	100	100000
5	100	Formwork	1000	100	100000
6	100	Reinforcement	1000	100	100000
7	100	Curing	1000	100	100000
8	100	Inspection	1000	100	100000
9	100	Completion	1000	100	100000

Color Index

Color	Code
White	1
Yellow	2
Red	3
Green	4
Blue	5
Purple	6
Brown	7
Black	8