

Proposal Basic Information	
Proposal File No.	JNAC/BP/0114/W2/2020
Owner Name	KAUSHAL KISHORE MANDAL
Khata No	401
Plot No	771,773C
Village Name	KADMA
Use	Residential
SubUse	Bungalow/ Dwelling / Non Apartment

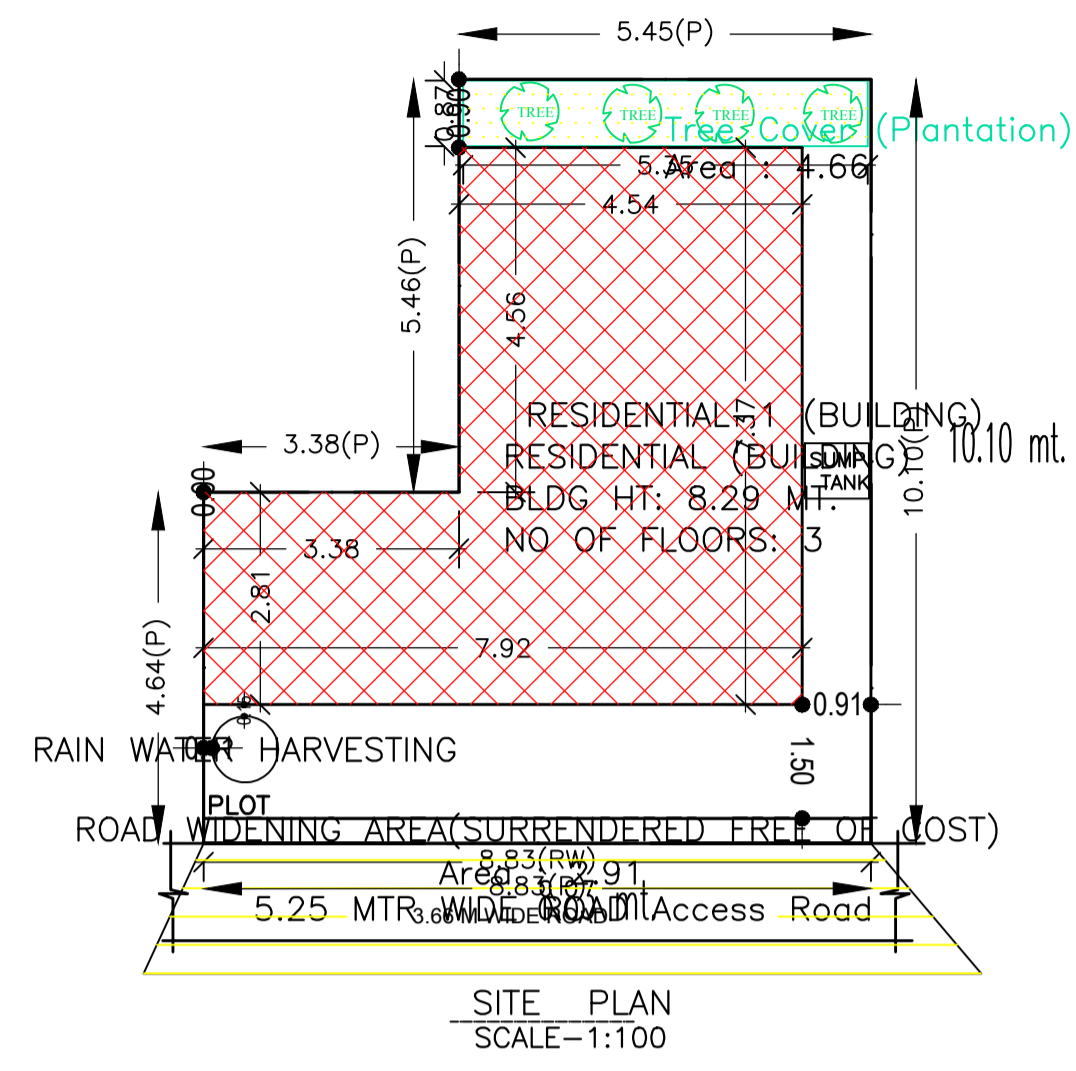

SITE PLAN

AREA STATEMENT	VERSION NO. : 1.0.61
JAMSHEDPUR NAC	VERSION DATE: 16/10/2020
PROJECT DETAIL:	
Region: JHARKHAND URBAN LOCAL BODIES	Plot Use: Residential
District: EAST SINGHBHUM	Plot SubUse: Bungalow/ Dwelling / Non Apartment
Authority: JAMSHEDPUR NAC	Plot/Nearby/Religious Structure: NA
Inward No: JNAC/BP/0114/W2/2020	Plot/SubPlot No: 771,773C
Application Type: General Proposal	North: Plot No. - MANGALA MALLICK
Project Type: Building Permission	South: Road Width - 3.66
	East: Road Width - 3.01
Location of Development Area: Old Area	West: Plot No. - SHAKUNTALA MALLICK
AREA DETAILS:	
AREA OF PLOT (Minimum)	(A) 70.74
Deduction for NetPlot Area	
Surrender Free of Cost	2.91
Total	
NET AREA OF PLOT(Gross Plot Area - Deduction from Gross Plot area)	(A-Deductions) 67.83
Deduction for Balance Plot Area(from Gross Plot Area)	
Surrender Free of Cost	2.91
Common Plot	4.66
Total	7.57
BALANCE AREA OF PLOT(Net Plot Area - Recreational/Amenity space)	(A-Deductions) 63.17
Plot Area for FAR (Net Plot Area + RoadWidening Area)	(A-Deductions) 70.74
COVERAGE CHECK	
Permissible Coverage area (70.00 %)	47.48
Proposed Coverage Area (63.32 %)	42.95
Total Prop. Coverage Area (63.32 %)	42.95
Balance coverage area (6.68 %)	4.53
FAR CHECK	
Perm. FAR Area (1.80)	127.33
Total Perm. FAR area	127.33
Residential FAR	85.91
Proposed FAR Area	93.88
Total Proposed FAR Area	93.88
Consumed FAR (Factor)	1.33
Balance FAR Area	33.45
BUILT UP AREA CHECK	
Total Proposed BuiltUp Area	128.85
ARCHITECT (Regd)	NIKHIL SHUKLA
ENGINEER (Regd)	
SUPERVISOR (Regd)	
OWNER (Regd)	KAUSHAL KISHORE MANDAL
DEVELOPMENT AUTHORITY	LOCAL BODY

COLOR INDEX	
PLOT BOUNDARY	Black
ABUTTING ROAD	Red
PROPOSED CONSTRUCTION	Green
COMMON PLOT	Yellow
ROAD WIDENING AREA	Blue
EXISTING (To be retained)	Orange
EXISTING (To be demolished)	Light Blue

Buildingwise Floor FAR Details

Floor Name	Building Name		Total	
	Proposed Built Up Area (Sq.mt.)	Proposed FAR Area (Sq.mt.)	Total Proposed Built Up Area (Sq.mt.)	Total FAR Area (Sq.mt.)
Parking Floor	42.95	7.98	42.95	7.98
First Floor	42.95	42.95	42.95	42.95
Second Floor	42.95	42.95	42.95	42.95
Terrace Floor	0.00	0.00	0.00	0.00
Total :	128.85	93.88	128.85	93.88

Building USE/SUBUSE Details

Building Name	Building Use	Building SubUse	Building Structure
RESIDENTIAL (BUILDING)	Residential	Bungalow/ Dwelling / Non Apartment	Non-Highrise

FAR & Tenement Details (Table 4c-1)

Building	No. of Same Bldg	Total Built Up Area (Sq.mt.)	Deductions (Area in Sq.mt.)		Proposed FAR Area (Sq.mt.)	Add Area In FAR (Sq.mt.)	Total FAR Area (Sq.mt.)	Total Consumed Additional FAR Area (Sq.mt.)	Trmt (No.)
			Parking	Resi.					
RESIDENTIAL (BUILDING)	1	128.85	34.97	85.90	7.98	93.88	93.88	01	
Grand Total :	1	128.85	34.97	85.90	7.98	93.88	93.88	01	

LTP NAME AND SIGNATURE	STRUCTURAL ENG'S NAME AND SIGNATURE	BUILDER NAME AND SIGNATURE	DIGITAL SIGNATURE
NIKHIL SHUKLA JNAC/ARC/0015/2019			

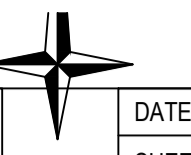

Proposal Basic Information

Proposal File No.	JNAC/BP/0114/W2/2020
Owner Name	KAUSHAL KISHORE MANDAL
Khata No	401
Plot No	771.773C
Village Name	KADMA
Use	Residential
SubUse	Bungalow/ Dwelling / Non Apartment

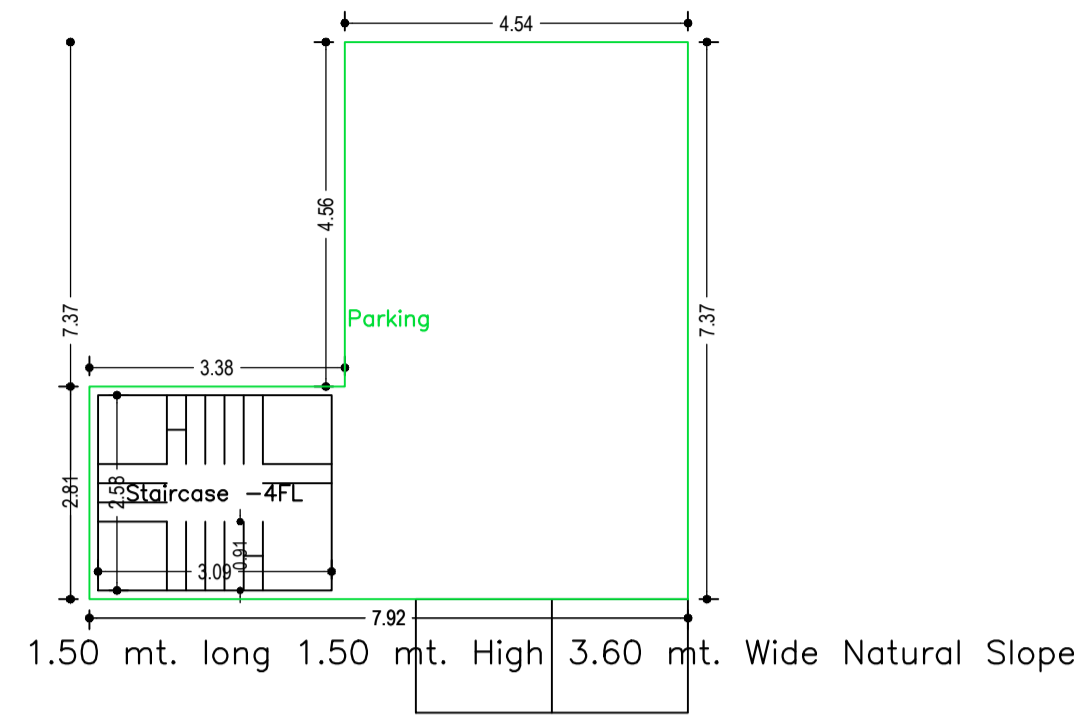

PARKING FLOOR PLAN
(SCALE 1:100)

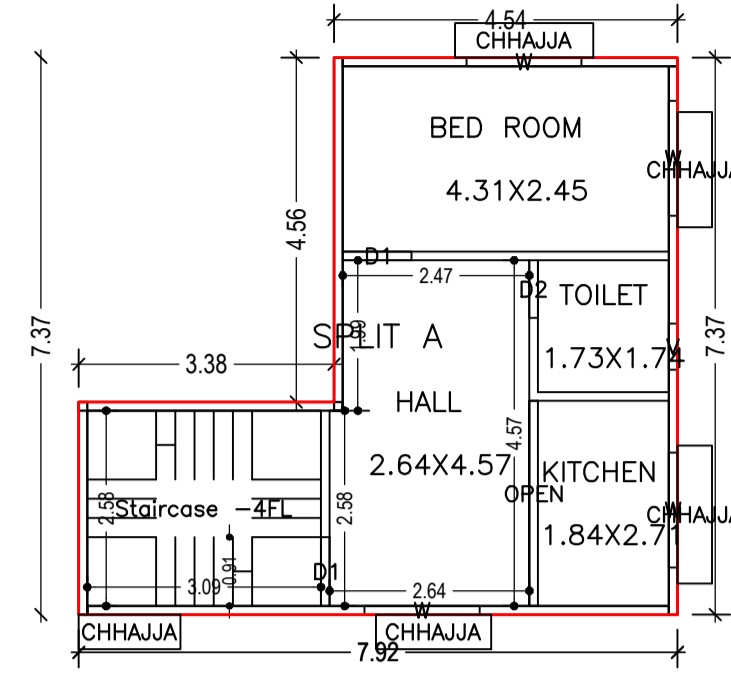

FIRST FLOOR PLAN
(Proposed)
(SCALE 1:100)

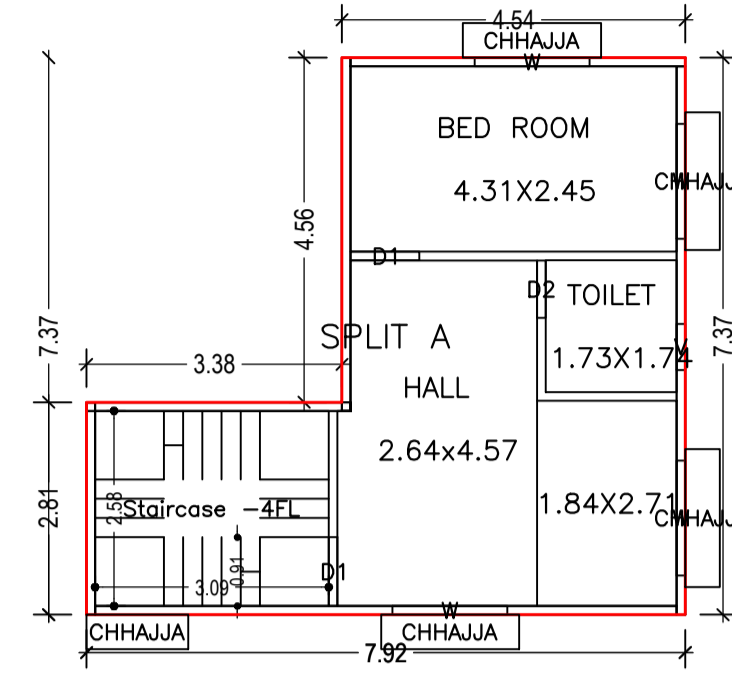

SECOND FLOOR PLAN
(Proposed)
(SCALE 1:100)

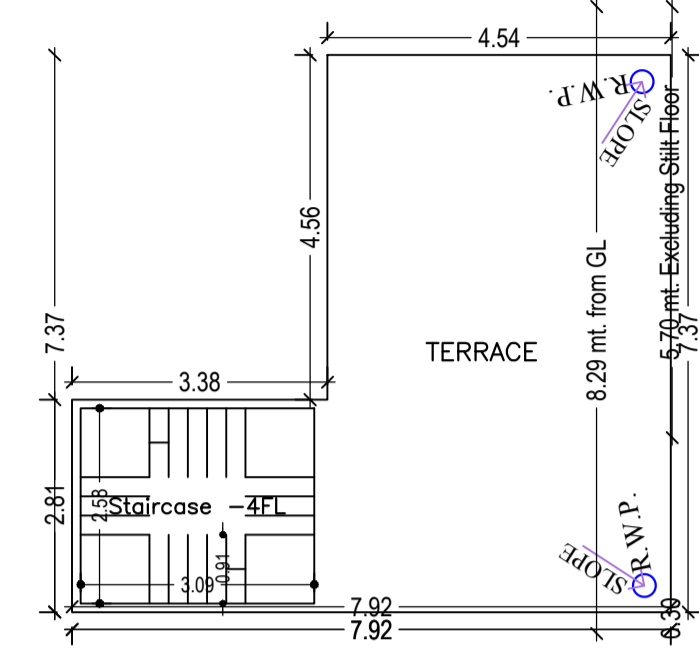

TERRACE FLOOR PLAN
(SCALE 1:100)

Building :RESIDENTIAL (BUILDING)

Floor Name	Total Built Up Area (Sq.mt.)	Deductions (Area in Sq.mt.)	Proposed FAR Area (Sq.mt.)	Add Area In FAR (Sq.mt.)	Total FAR Area (Sq.mt.)	Total Consumed Additional FAR Area (Sq.mt.)	Tnmt (No.)
Parking Floor	42.95	34.97	0.00	7.98	7.98	7.98	00
First Floor	42.95	0.00	42.95	0.00	42.95	42.95	01
Second Floor	42.95	0.00	42.95	0.00	42.95	42.95	00
Terrace Floor	0.00	0.00	0.00	0.00	0.00	0.00	00
Total :	128.85	34.97	85.90	7.98	93.88	93.88	01
Total Number of Same Buildings :	1						
Total :	128.85	34.97	85.90	7.98	93.88	93.88	01

SCHEDULE OF DOOR:

BUILDING NAME	NAME	LENGTH	HEIGHT	NOS
RESIDENTIAL (BUILDING)	D2	0.76	2.13	02
RESIDENTIAL (BUILDING)	D1	0.91	2.13	04
RESIDENTIAL (BUILDING)	OPEN	2.71	2.13	01

SCHEDULE OF WINDOW/VENTILATION:

BUILDING NAME	NAME	LENGTH	HEIGHT	NOS
RESIDENTIAL (BUILDING)	V	0.61	0.61	02
RESIDENTIAL (BUILDING)	W	1.52	1.22	08

UnitBUA Table for Building :RESIDENTIAL (BUILDING)

FLOOR	Name	UnitBUA Type	UnitBUA Area	Carpet Area	No. of Rooms	No. of Tenement
FIRST FLOOR PLAN	SPLIT A	FLAT	85.91	78.97	4	1
SECOND FLOOR PLAN	SPLIT A	FLAT	0.00	0.00	3	0
Total:	-	-	85.91	78.97	7	1

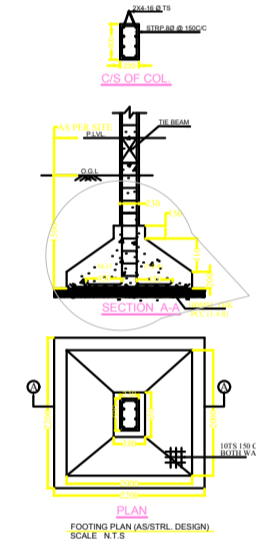
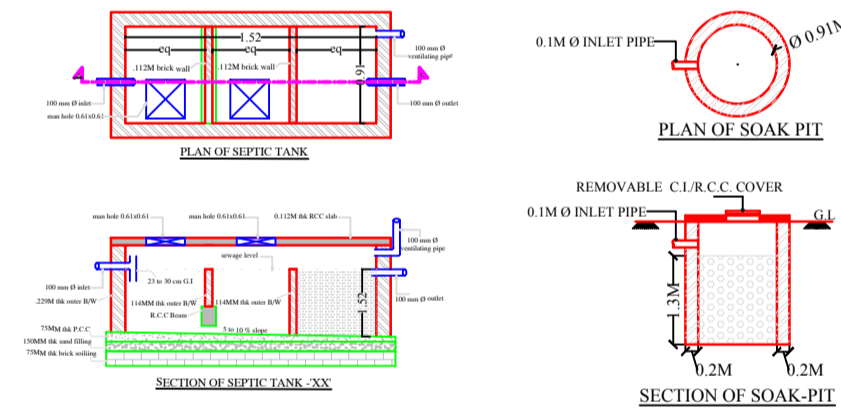

LTP NAME AND SIGNATURE	STRUCTURAL ENG'S NAME AND SIGNATURE	BUILDER NAME AND SIGNATURE	DIGITAL SIGNATURE
NIKHIL SHUKLA JNAC/ARC/0015/2019			

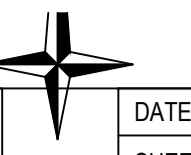

Proposal Basic Information	
Proposal File No.	JNAC/BP/0114/W2/2020
Owner Name	KAUSHAL KISHORE MANDAL
Khata No	401
Plot No	771,773C
Village Name	KADMA
Use	Residential
SubUse	Bungalow/ Dwelling / Non Apartment

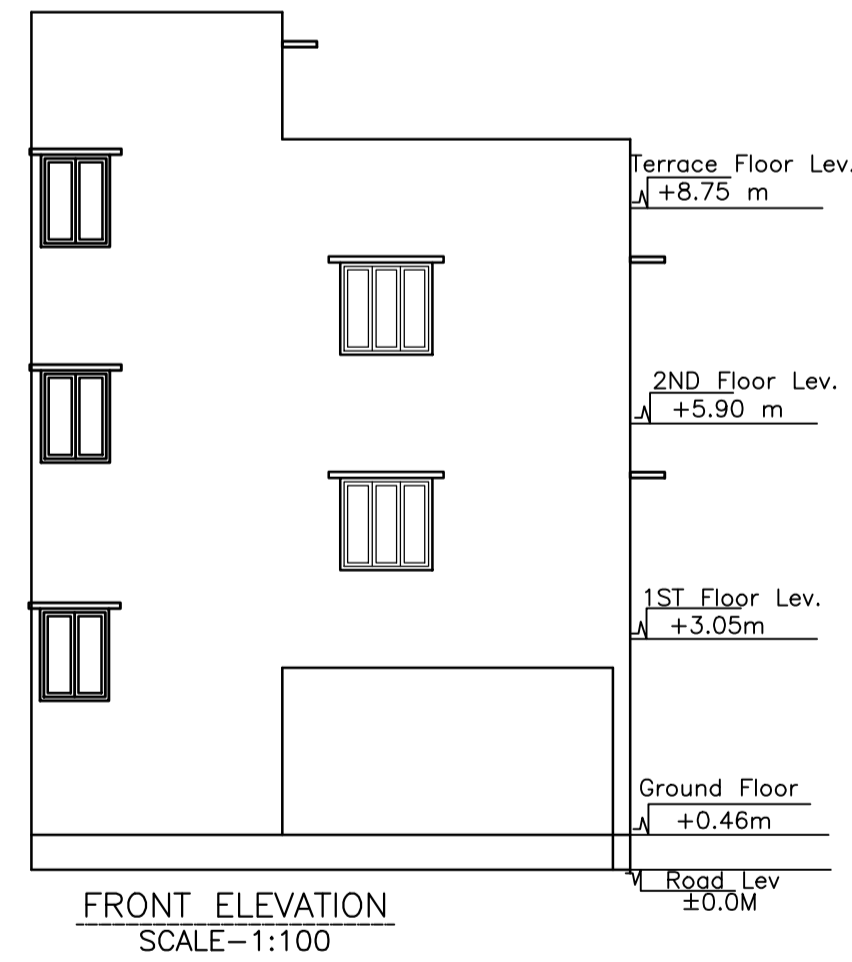
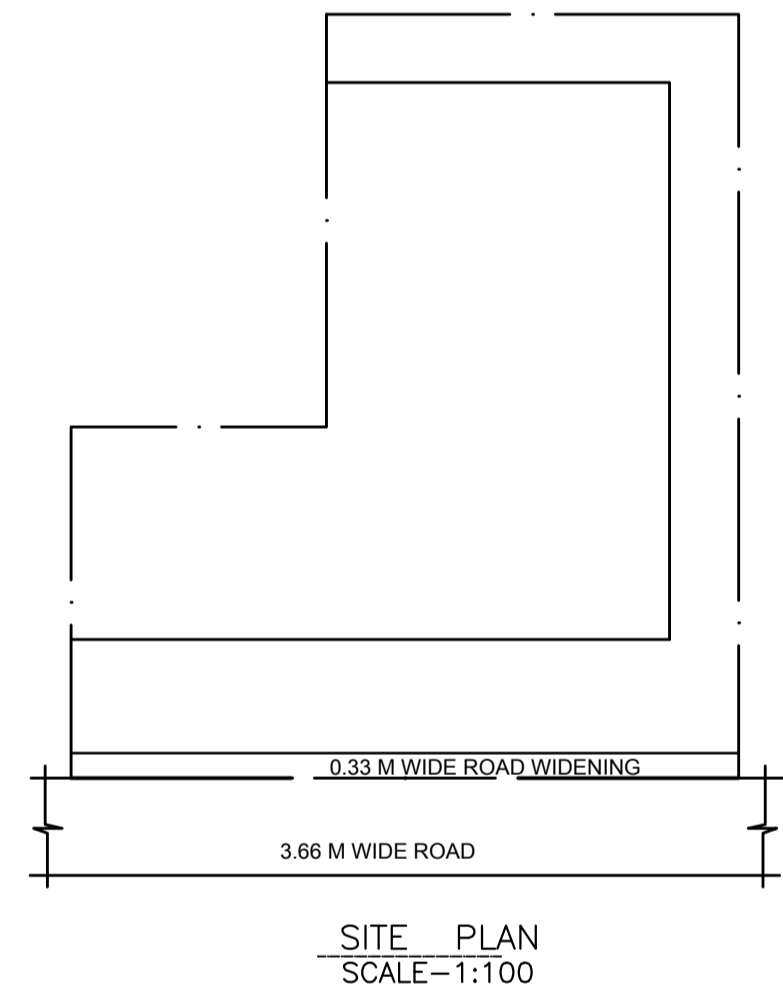
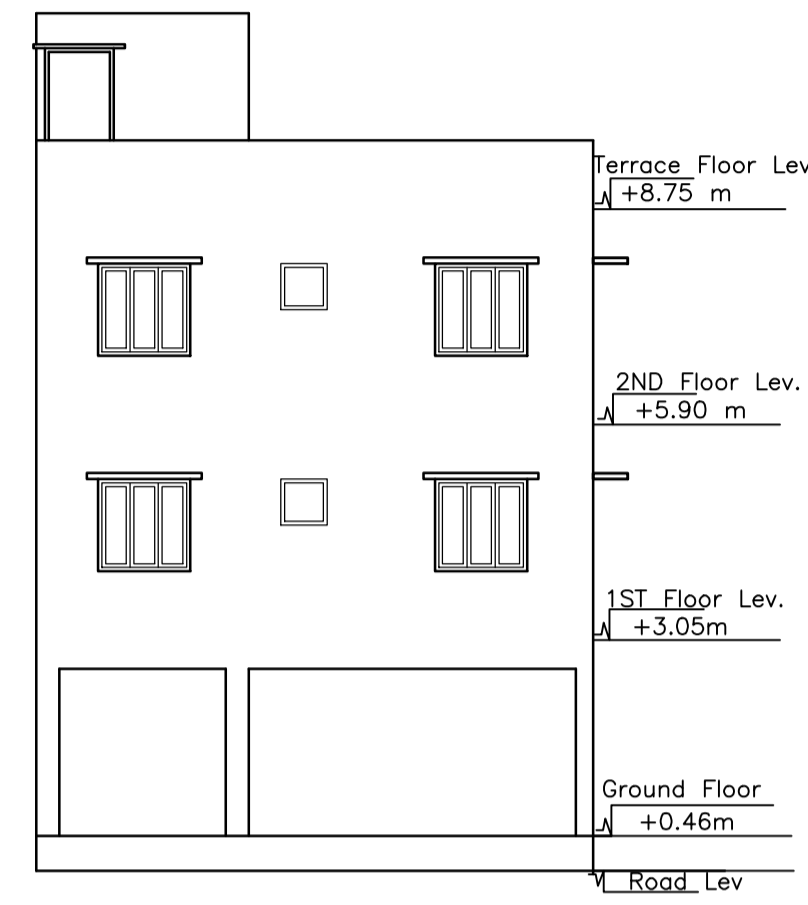
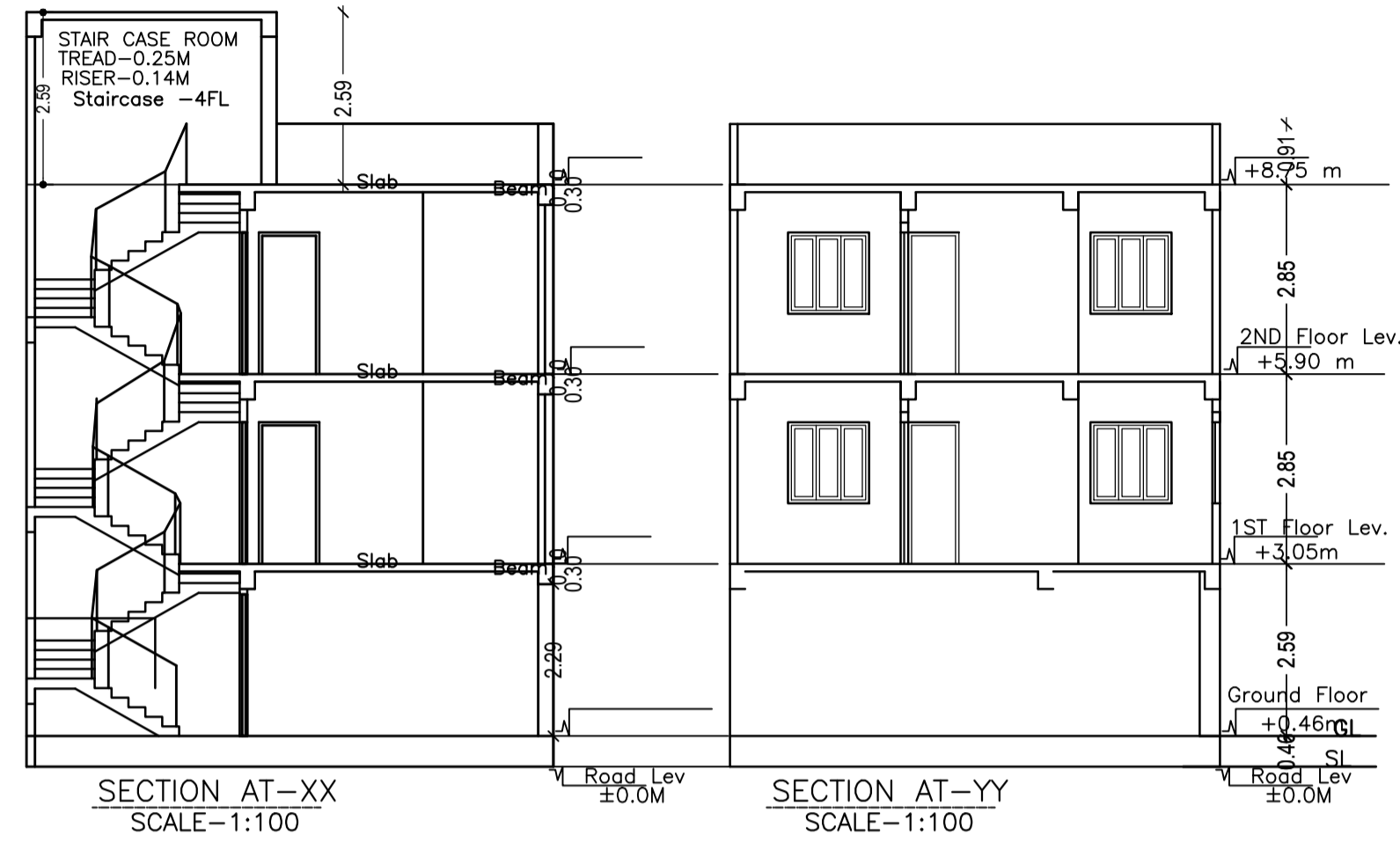

LTP NAME AND SIGNATURE	STRUCTURAL ENG'S NAME AND SIGNATURE	BUILDER NAME AND SIGNATURE	DIGITAL SIGNATURE
NIKHIL SHUKLA JNAC/ARC/0015/2019			