

SITE PLAN
SCALE-1:200

FAR & Tenement Details (Table 4c-1)

Building	No. of Same Bldg	Total Built Up Area (Sq.mt.)	Proposed FAR Area (Sq.mt.)		Total FAR Area (Sq.mt.)	Total Consumed Additional FAR Area (Sq.mt.)	Tenmt (No.)
			Resi.	Stair			
A (NARESH KUMAR AND NAND KUMAR)	1	151.02	139.58	11.44	151.02	151.02	01
Grand Total :	1	151.02	139.58	11.44	151.02	151.02	01

Proposal Basic Information

Proposal File No.	JNAC/BP/0027/W2/2020
Owner Name	NARESH KUMAR AND NAND KUMAR PATEL
Khata No	NIL
Plot No	E/307
Village Name	SONARI
Use	Residential
SubUse	Row House

AREA STATEMENT JAMSHEDPUR NAC	VERSION NO : 1.0.44 VERSION DATE: 29/04/2019
PROJECT DETAIL:	
Region: JHARKHAND URBAN LOCAL BODIES	Plot Use: Residential
District: EAST SINGHBHUM	Plot SubUse: Row House
Authority: JAMSHEDPUR NAC	PlotNearby/ReligiousStructure: NA
Inward_No: JNAC/BP/0027/W2/2020	PlotSubPlot No: E/307
Application Type: General Proposal	North: Road Width - 9.50M
Project Type: Building Permission	South: Road Width - 4.50M
Nature of Development: New	East: Plot No. - E/308
Location of Development Area: Old Area	West: Plot No. - E/306
AREA DETAILS:	
AREA OF PLOT (Minimum)	(A) 111.33
NET AREA OF PLOT(Gross Plot Area - Deduction from Gross Plot area)	(A-Deductions) 111.33
Deduction for Balance Plot Area(from Gross Plot Area)	
Common Plot Total	23.65
BALANCE AREA OF PLOT(Net Plot Area - Recreational/Amenity space)	(A-Deductions) 87.68
PLOT AREA FOR COVERAGE(Net Plot Area)	(A-Deductions) 111.33
Plot Area for FAR (Net Plot Area + RoadWidening Area)	(A-Deductions) 111.33
COVERAGE CHECK	
Permissible Coverage area (70.00 %)	77.93
Proposed Coverage Area (62.69 %)	69.79
Total Prop. Coverage Area (62.69 %)	69.79
Balance coverage area (7.31 %)	8.14
FAR CHECK	
Perm. FAR Area (2.50)	278.33
Total Perm. FAR area	278.33
Residential FAR	139.57
Proposed FAR Area	151.01
Total Proposed FAR Area	151.01
Consumed FAR (Factor)	1.36
Balance FAR Area	127.32
BUILT UP AREA CHECK	
Total Proposed BuiltUp Area	151.02
ARCHITECT (Regd)	Shreyashi Haldar
ENGINEER (Regd)	
SUPERVISOR (Regd)	
OWNER (Regd)	NARESH KUMAR AND NAND KUMAR PATEL
DEVELOPMENT AUTHORITY LOCAL BODY	

COLOR INDEX	
PLOT BOUNDARY	Black
ABUTTING ROAD	Green
PROPOSED CONSTRUCTION	Red
COMMON PLOT	Yellow
ROAD WIDENING AREA	Blue
EXISTING (To be retained)	Light Blue
EXISTING (To be demolished)	Light Yellow

Buildingwise Floor FAR Details

Floor Name	Building Name A (NARESH KUMAR AND NAND KUMAR)		Total	
	Proposed Built Up Area (Sq.mt.)	Proposed FAR Area (Sq.mt.)	Total Proposed Built Up Area (Sq.mt.)	Total FAR Area (Sq.mt.)
Parking Floor	11.44	11.44	11.44	11.44
First Floor	69.79	69.79	69.79	69.79
Second Floor	69.79	69.79	69.79	69.79
Terrace Floor	0.00	0.00	0.00	0.00
Total :	151.02	151.02	151.02	151.02

Building USE/SUBUSE Details

Building Name	Building Use	Building SubUse	Building Structure
A (NARESH KUMAR AND NAND KUMAR)	Residential	Semidetached	Non-Highrise

LTP NAME AND SIGNATURE	STRUCTURAL ENG'S NAME AND SIGNATURE	BUILDER NAME AND SIGNATURE	DIGITAL SIGNATURE
Shreyashi Haldar JNAC/DFTMN/0009/2016			

Proposal Basic Information	
Proposal File No.	JNAC/BP/0027/W2/2020
Owner Name	NARESH KUMAR AND NAND KUMAR PATEL
Khata No	NIL
Plot No	E/307
Village Name	SONARI
Use	Residential
SubUse	Row House

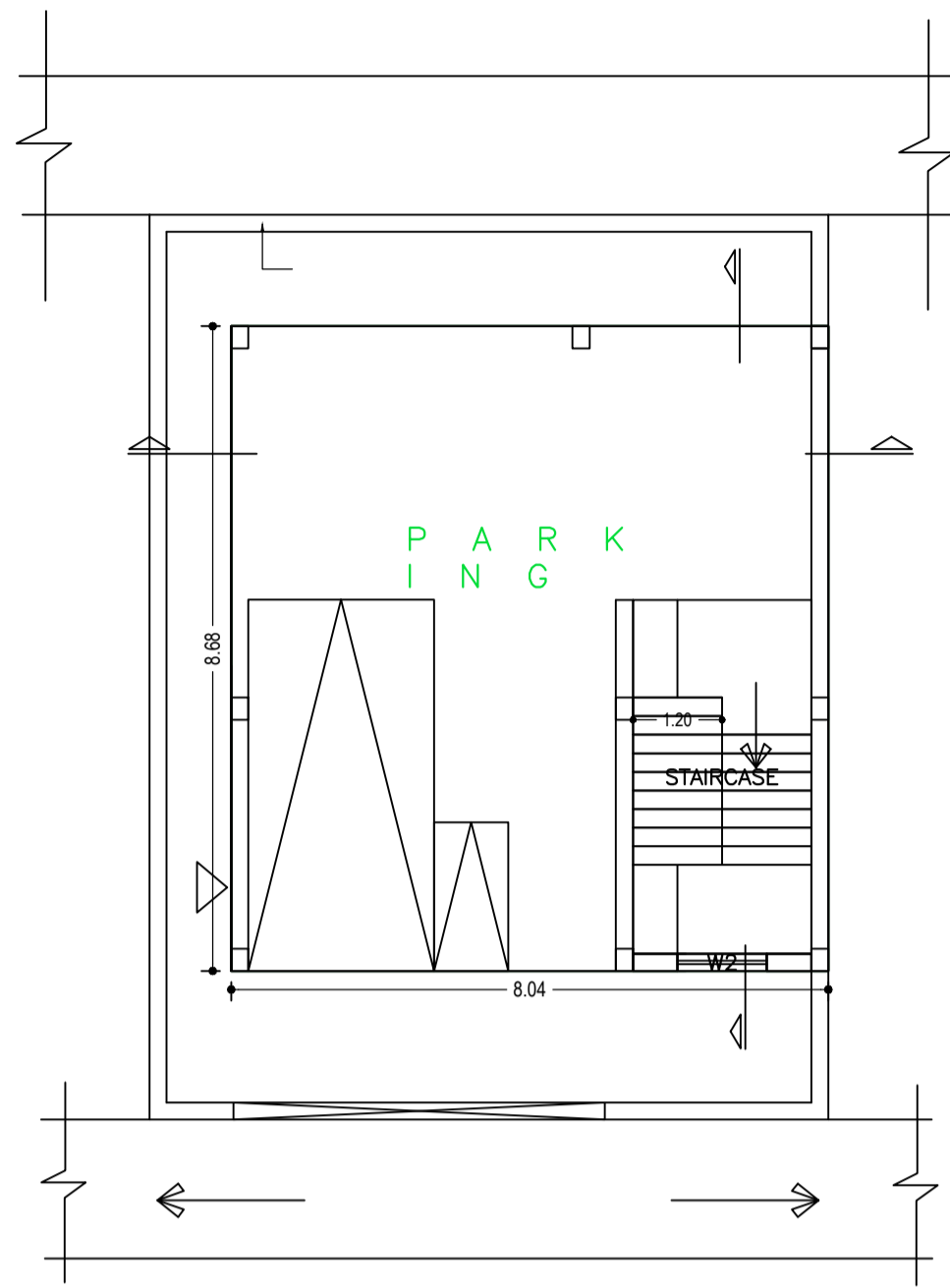

PARKING FLOOR PLAN (SCALE 1:100)

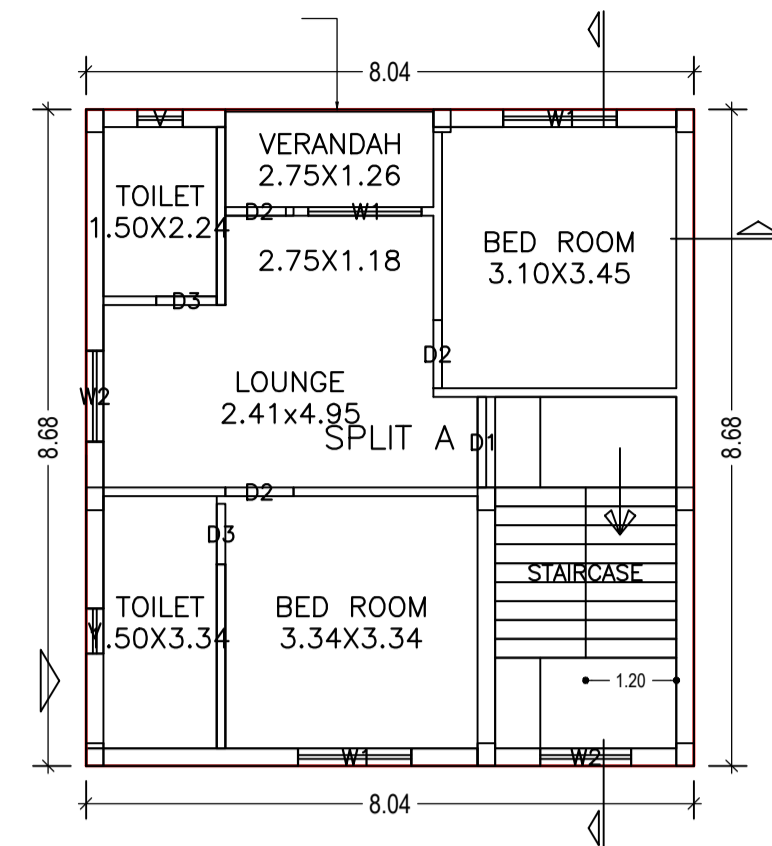

SECOND FLOOR PLAN (Proposed) (SCALE 1:100)

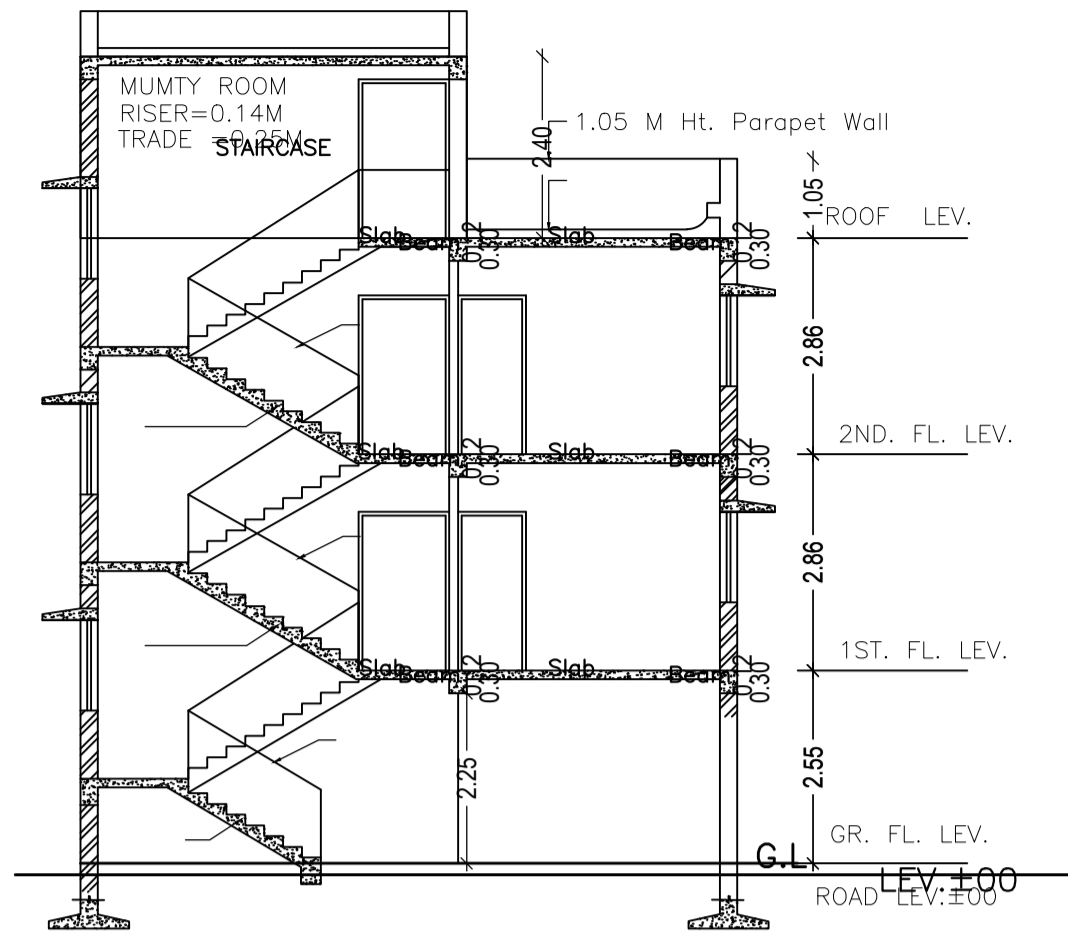

SECTION - Y-Y (SCALE=1:100)

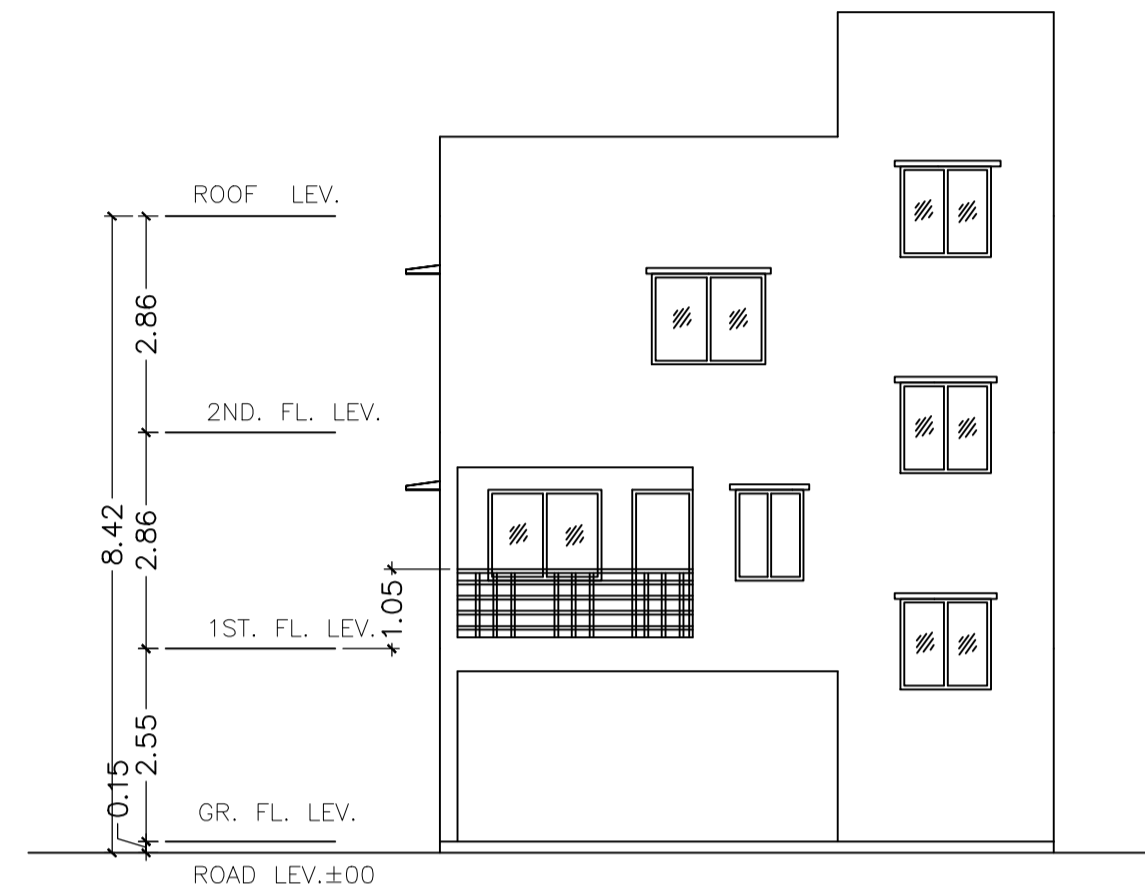

FRONT ELEVATION (SCALE=1:100)

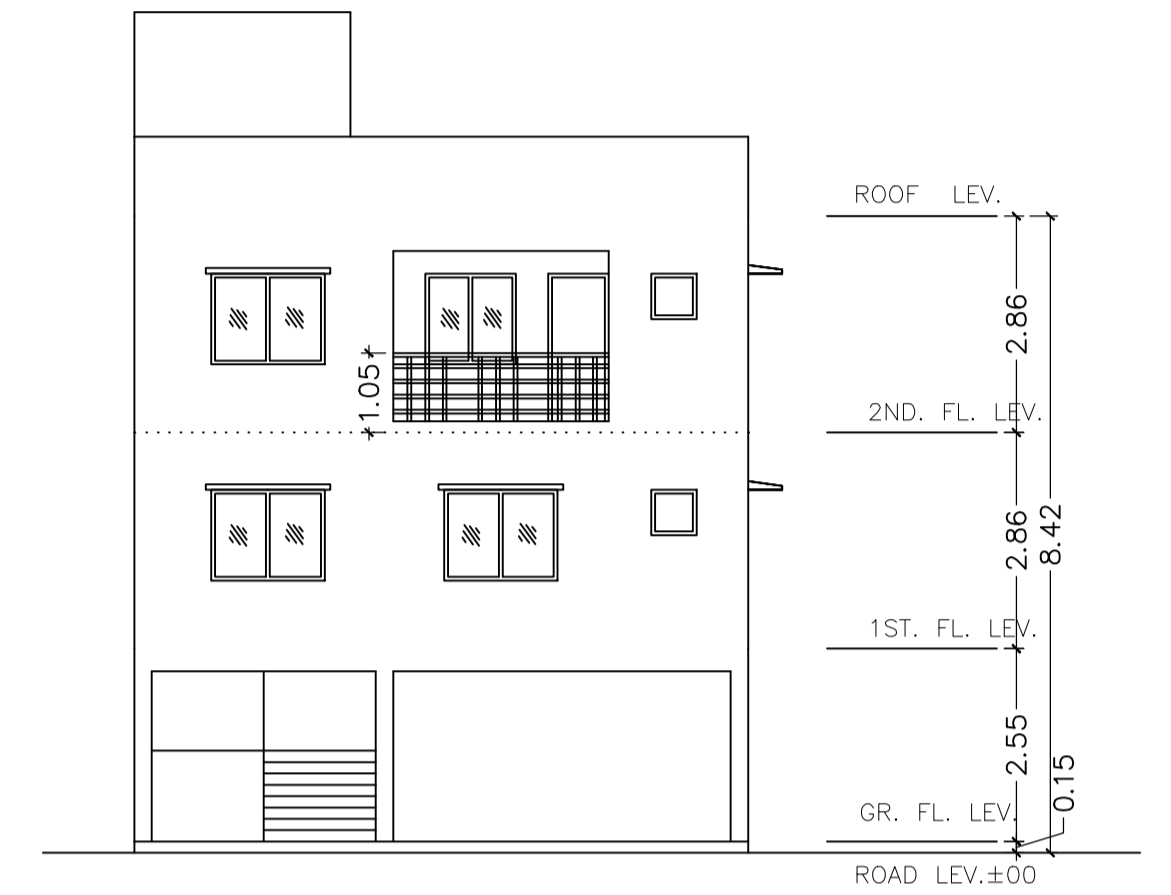

RARE SIDE ELEVATION (SCALE=1:100)

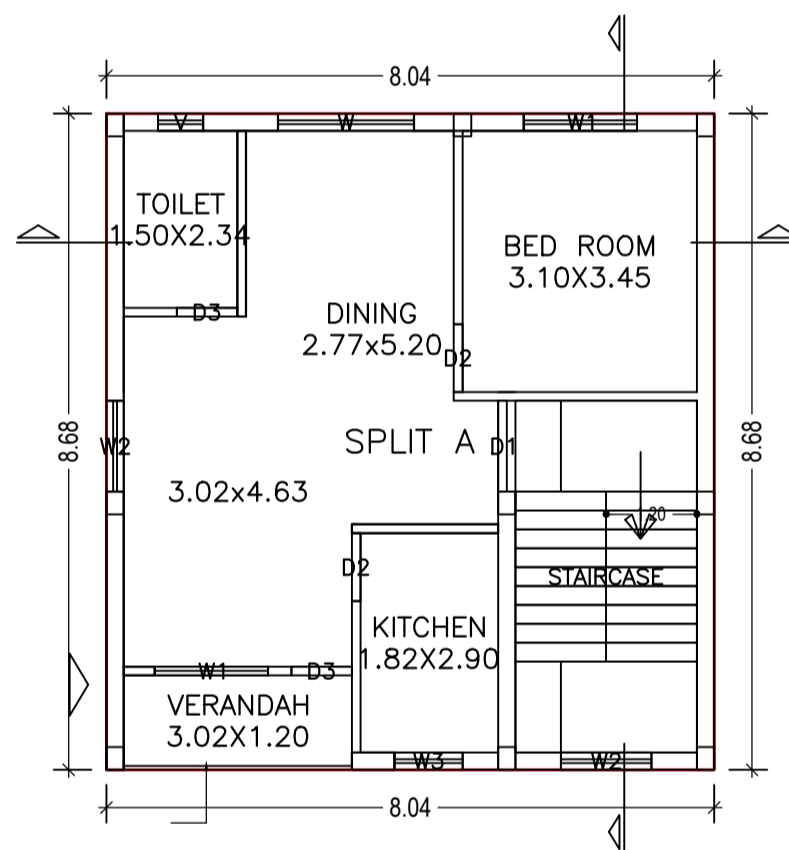

FIRST FLOOR PLAN (Proposed) (SCALE 1:100)

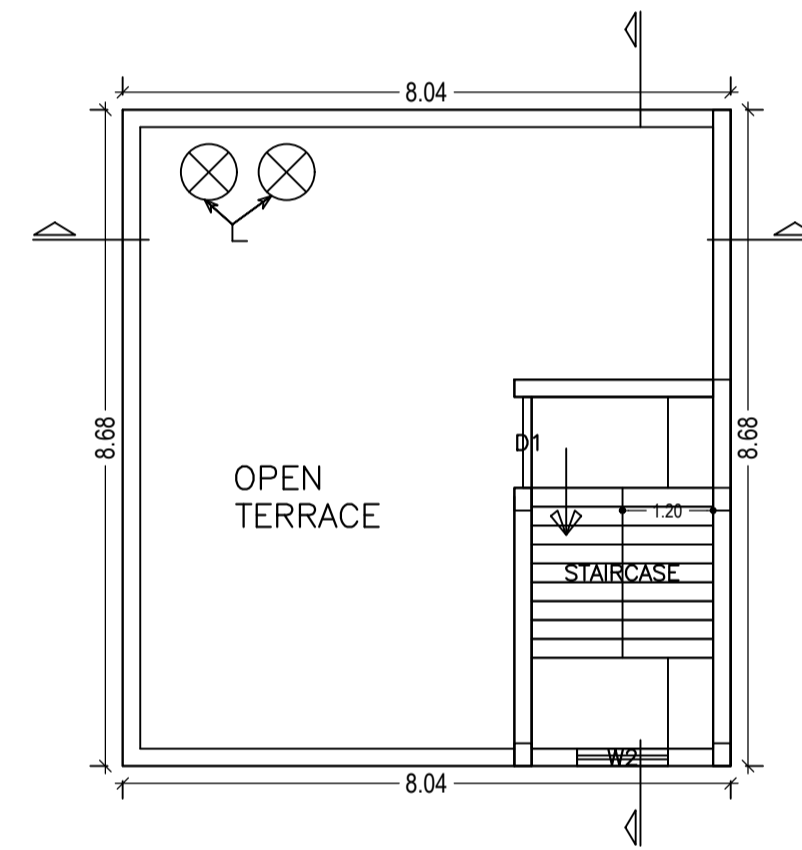

TERRACE FLOOR PLAN (SCALE 1:100)

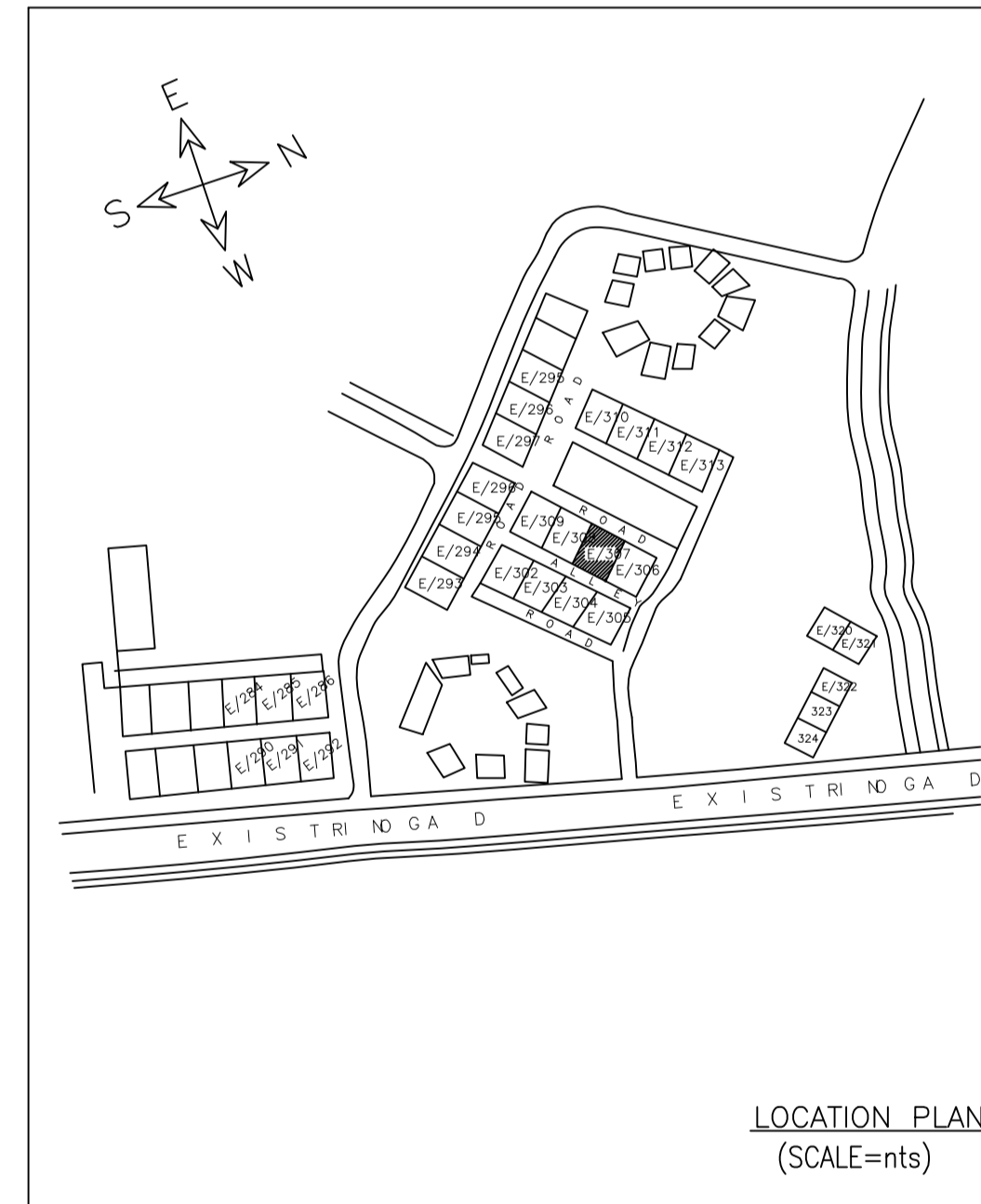

LOCATION PLAN (SCALE=nts)

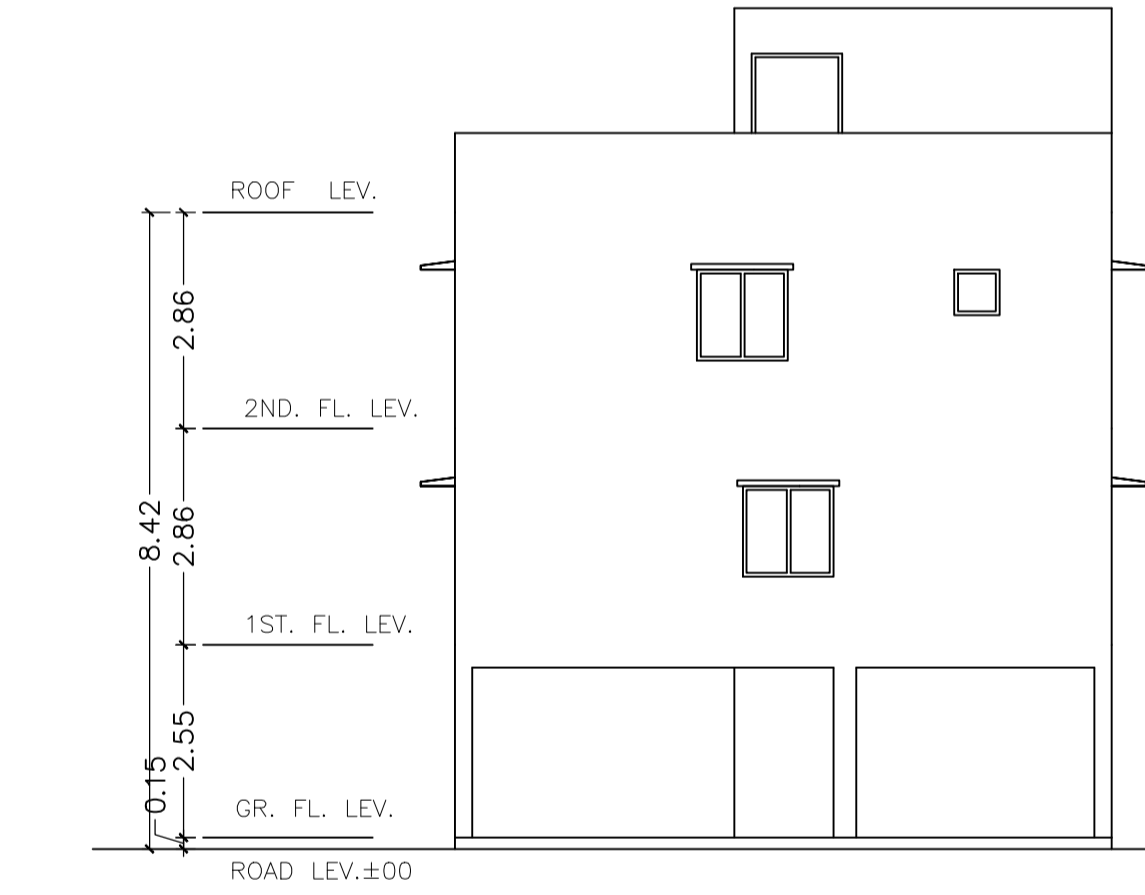

SIDE - A ELEVATION (SCALE=1:100)

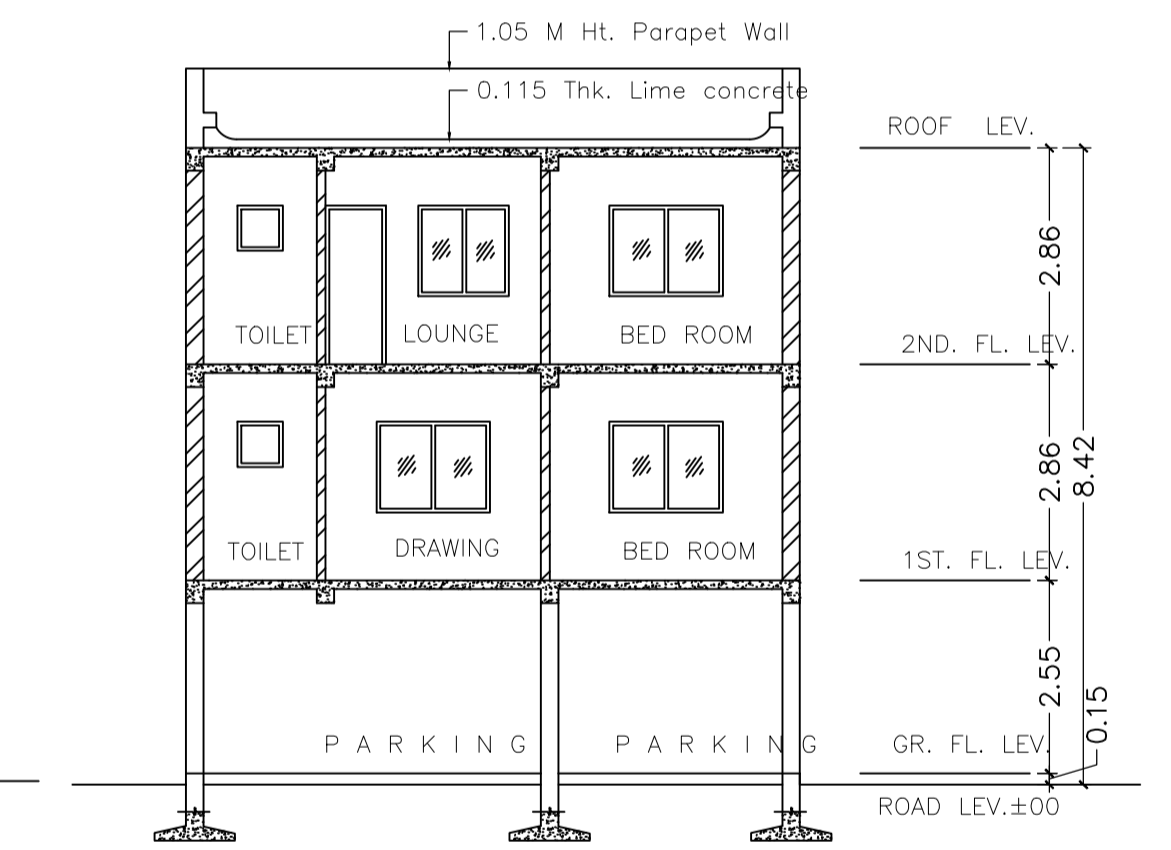

SECTION - X-X (SCALE=1:100)

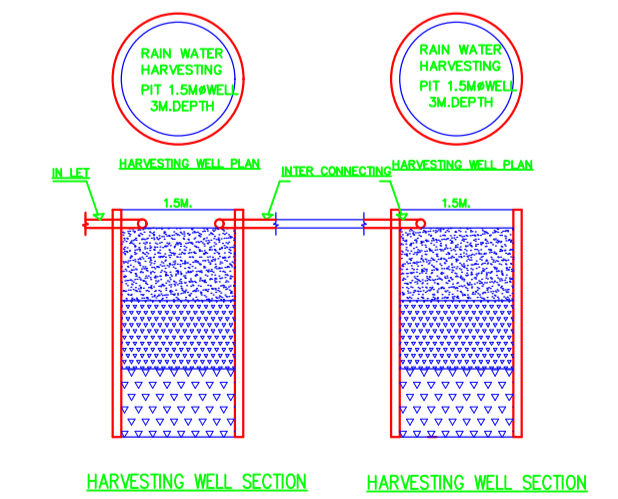

SCHEDULE OF DOOR:

BUILDING NAME	NAME	LENGTH	HEIGHT	NOS
A (NARESH KUMAR AND NAND KUMAR)	D3	0.80	2.10	04
A (NARESH KUMAR AND NAND KUMAR)	D2	0.90	2.10	05
A (NARESH KUMAR AND NAND KUMAR)	D1	1.20	2.10	02

SCHEDULE OF WINDOW/VENTILATION:

BUILDING NAME	NAME	LENGTH	HEIGHT	NOS
A (NARESH KUMAR AND NAND KUMAR)	V	0.60	0.60	03
A (NARESH KUMAR AND NAND KUMAR)	W3	0.90	1.20	01
A (NARESH KUMAR AND NAND KUMAR)	W2	1.20	1.20	06
A (NARESH KUMAR AND NAND KUMAR)	W1	1.50	1.20	05
A (NARESH KUMAR AND NAND KUMAR)	W	1.80	1.20	01

UnitBUA Table for Building :A (NARESH KUMAR AND NAND KUMAR)

FLOOR	Name	UnitBUA Type	UnitBUA Area	Carpet Area	No. of Rooms	No. of Tenement
FIRST FLOOR PLAN	SPLIT A	FLAT	139.57	133.45	5	1
SECOND FLOOR PLAN	SPLIT A	FLAT	0.00	0.00	6	0
Total:	-	-	139.57	133.45	11	1

Building :A (NARESH KUMAR AND NAND KUMAR)

Floor Name	Total Built Up Area (Sq.mt.)	Proposed FAR Area (Sq.mt.) Resi.	Add Area in FAR (Sq.mt.) Stair	Total FAR Area (Sq.mt.)	Total Consumed Additional FAR Area (Sq.mt.)	Tnmt (No.)
Parking Floor	11.44	0.00	11.44	11.44	11.44	00
First Floor	69.79	69.79	0.00	69.79	69.79	01
Second Floor	69.79	69.79	0.00	69.79	69.79	00
Terrace Floor	0.00	0.00	0.00	0.00	0.00	00
Total:	151.02	139.58	11.44	151.02	151.02	01
Total Number of Same Buildings	1					
Total:	151.02	139.58	11.44	151.02	151.02	01

LTP NAME AND SIGNATURE	STRUCTURAL ENG'S NAME AND SIGNATURE	BUILDER NAME AND SIGNATURE	DIGITAL SIGNATURE
Shreyashi Haldar JNAC/DFTMN/0009/2016			

Proposal Basic Information	
Proposal File No.	JNAC/BP/0027/W2/2020
Owner Name	NARESH KUMAR AND NAND KUMAR PATEL
Khata No	NIL
Plot No	E/307
Village Name	SONARI
Use	Residential
SubUse	Row House

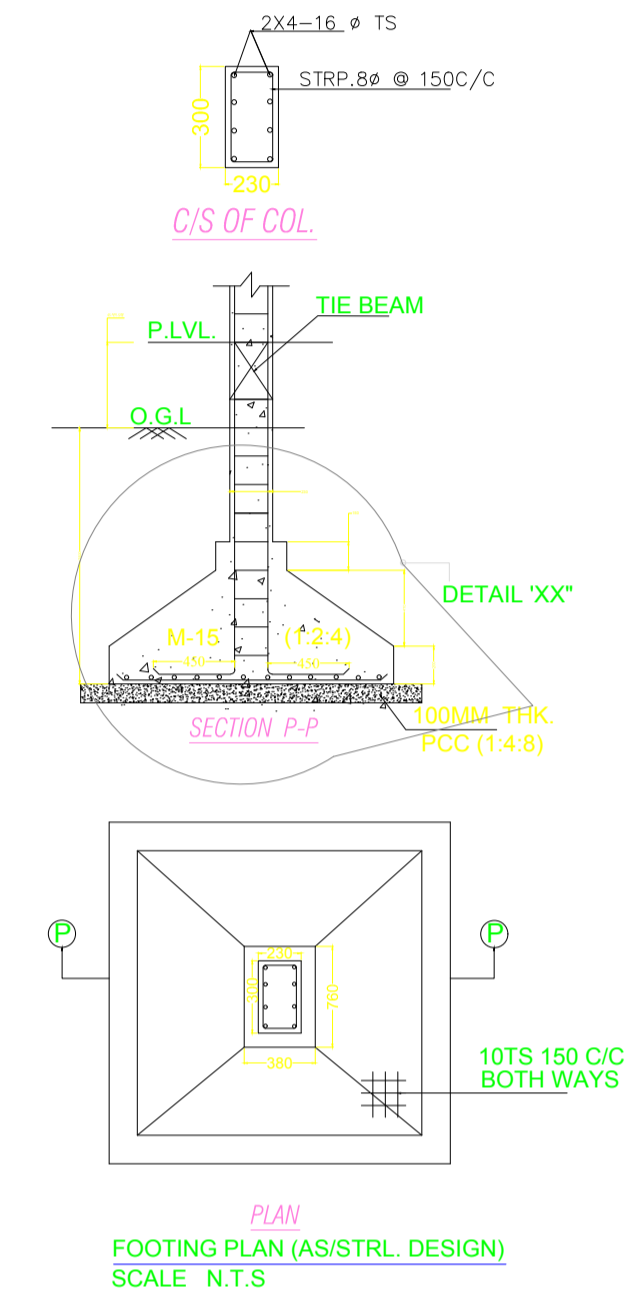

LTP NAME AND SIGNATURE	STRUCTURAL ENG'S NAME AND SIGNATURE	BUILDER NAME AND SIGNATURE	DIGITAL SIGNATURE
Shreyashi Halder JNAC/DFTMN/0009/2016			