

Proposal Basic Information	
Proposal File No.	JNAC/BP/0017/W3/2020
Owner Name	Sri Shailendra Kr. Singh and Others
Khata No	Nil
Plot No	32-A Ranikudar West Area
Village Name	KADMA
Use	Residential
SubUse	Bungalow/ Dwelling / Non Apartment

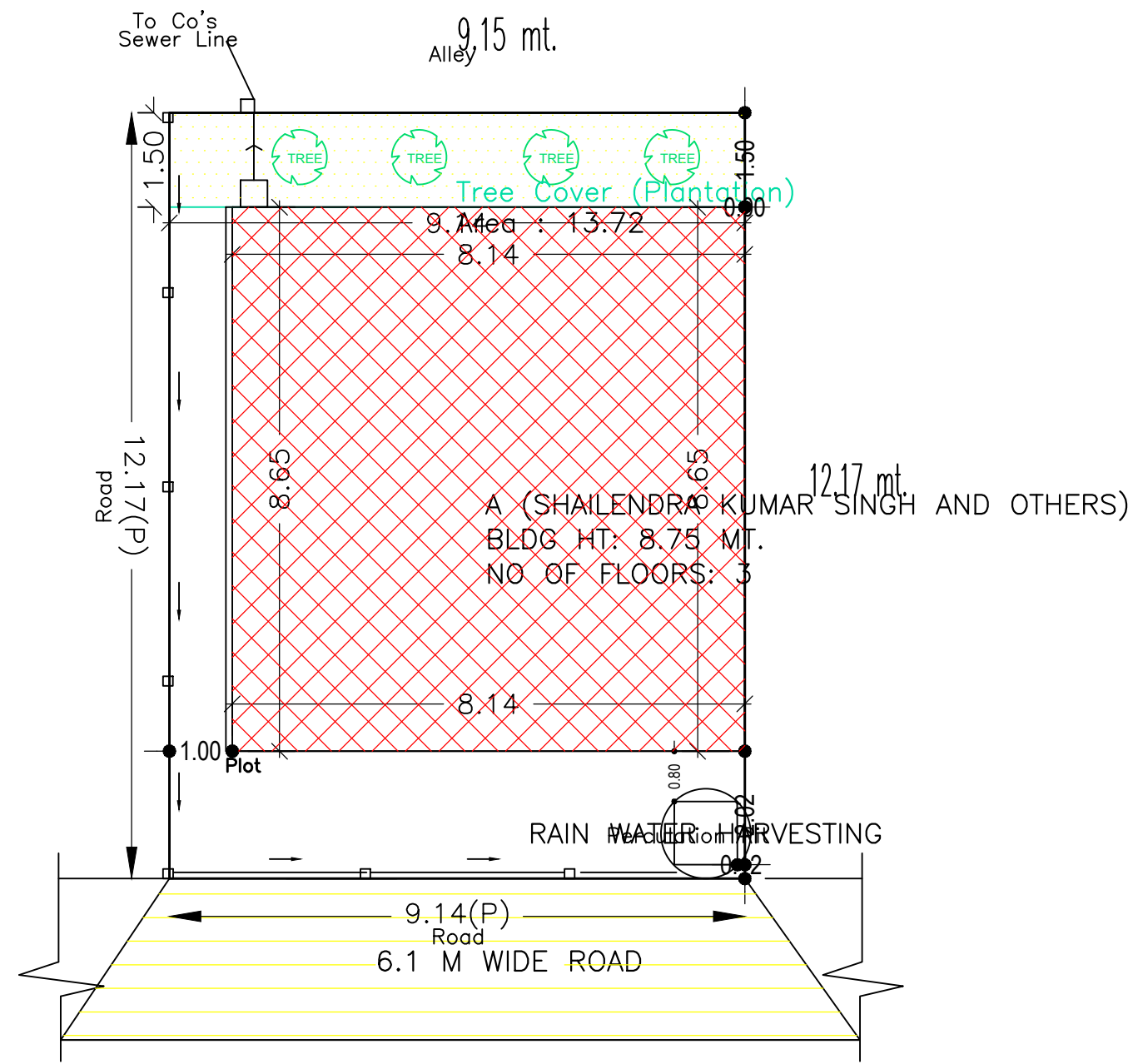

SITE PLAN
Scale: (1:100)

AREA STATEMENT JAMSHEDPUR NAC	VERSION NO.: 1.0.43 VERSION DATE: 29/04/2019
PROJECT DETAIL:	
Region: JHARKHAND URBAN	Plot Use: Residential
LOCAL BODIES	Plot SubUse: Bungalow/ Dwelling / Non Apartment
District: EAST SINGHBHUM	PlotNearbyReligiousStructure: NA
Authority: JAMSHEDPUR NAC	Plot/SubPlot No: 32-A Ranikudar West Area
Inward No: JNAC/BP/0017/W3/2020	North: Road Width - 9.45
Application Type: General Proposal	South: Survey No. - Alley
Project Type: Building Permission	East: Plot No. - 23
Nature of Development: New	West: Plot No. - 23B
Location of Development Area: Old Area	
AREA DETAILS:	
AREA OF PLOT (Minimum)	(A) 111.29 SQ.MT.
NET AREA OF PLOT(Gross Plot Area - Deduction from Gross Plot area)	(A-Deductions) 111.29
Deduction for Balance Plot Area(from Gross Plot Area)	
Common Plot	13.72
Total	13.72
BALANCE AREA OF PLOT(Net Plot Area - Recreational/Amenity space)	(A-Deductions) 97.58
PLOT AREA FOR COVERAGE(Net Plot Area)	(A-Deductions) 111.29
Plot Area for FAR (Net Plot Area + RoadWidening Area)	(A-Deductions) 111.29
COVERAGE CHECK	
Permissible Coverage area (70.00 %)	77.90
Proposed Coverage Area (63.26 %)	70.41
Total Prop. Coverage Area (63.26 %)	70.41
Balance coverage area (6.73 %)	7.49
FAR CHECK	
Perm. FAR Area (2.50)	278.23
Total Perm. FAR area	278.23
Residential FAR	140.83
Proposed FAR Area	149.11
Total Proposed FAR Area	149.11
Consumed FAR (Factor)	1.34
Balance FAR Area	129.12
BUILT UP AREA CHECK	
Total Proposed BuiltUp Area	211.23
ARCHITECT (Regd)	L K Suman
ENGINEER (Regd)	
SUPERVISOR (Regd)	
OWNER (Regd)	Sri Shailendra Kr. Singh and Others
DEVELOPMENT AUTHORITY LOCAL BODY	

COLOR INDEX	
PLOT BOUNDARY	Black
ABUTTING ROAD	Red
PROPOSED CONSTRUCTION	Green
COMMON PLOT	Yellow
ROAD WIDENING AREA	Orange
EXISTING (To be retained)	Blue
EXISTING (To be demolished)	Light Blue

Buildingwise Floor FAR Details

Floor Name	Building Name A (SHAIENDRA KUMAR SINGH AND OTHERS)		Total	
	Proposed Built Up Area (Sq.mt.)	Proposed FAR Area (Sq.mt.)	Total Proposed Built Up Area (Sq.mt.)	Total FAR Area (Sq.mt.)
Parking Floor	70.41	8.28	70.41	8.28
First Floor	70.41	70.41	70.41	70.41
Second Floor	70.41	70.41	70.41	70.41
Terrace Floor	0.00	0.00	0.00	0.00
Total :	211.23	149.10	211.23	149.10

Building USE/SUBUSE Details

Building Name	Building Use	Building SubUse	Building Structure
A (SHAIENDRA KUMAR SINGH AND OTHERS)	Residential	Bungalow/ Dwelling / Non Apartment	Non-Highrise

FAR & Tenement Details (Table 4c-1)

Building	No. of Same Bldg	Total Built Up Area (Sq.mt.)	Deductions (Area in Sq.mt.)		Proposed FAR Area (Sq.mt.)	Add Area In FAR (Sq.mt.)	Total FAR Area (Sq.mt.)	Total Consumed Additional FAR Area (Sq.mt.)	Tnmt (No.)
			Parking	Resi.					
A (SHAIENDRA KUMAR SINGH AND OTHERS)	1	211.23	62.13	140.82	8.28	149.10	149.10	01	
Grand Total :	1	211.23	62.13	140.82	8.28	149.10			

LTP NAME AND SIGNATURE	STRUCTURAL ENG'S NAME AND SIGNATURE	BUILDER NAME AND SIGNATURE	DIGITAL SIGNATURE
L K Suman JNAC/ENG/0006/2016			

Proposal Basic Information

Proposal File No.	JNAC/BP/0017/W3/2020
Owner Name	Sri Shailendra Kr. Singh and Others
Khata No	Nil
Plot No	32-A Ranikudar West Area
Village Name	KADMA
Use	Residential
SubUse	Bungalow/ Dwelling / Non Apartment

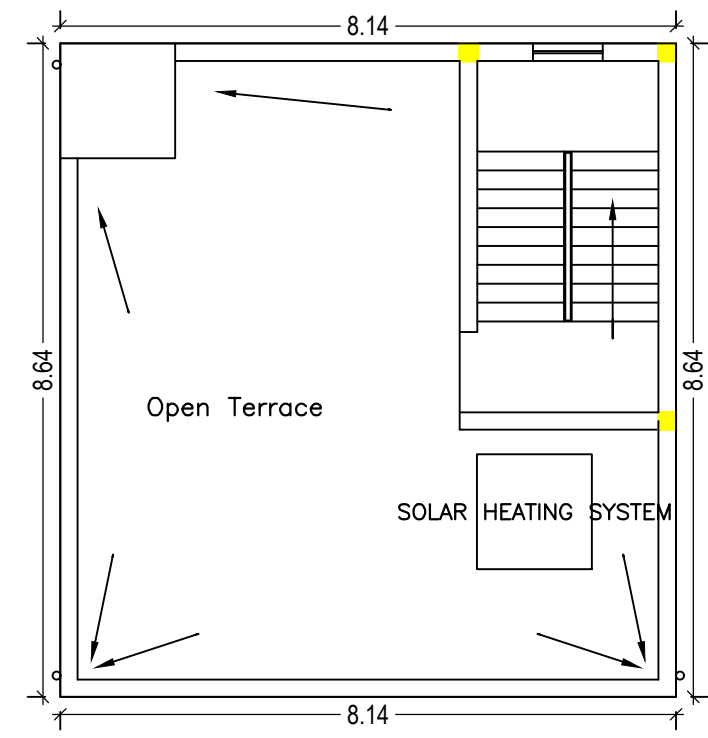

TERRACE FLOOR PLAN
(SCALE 1:100)

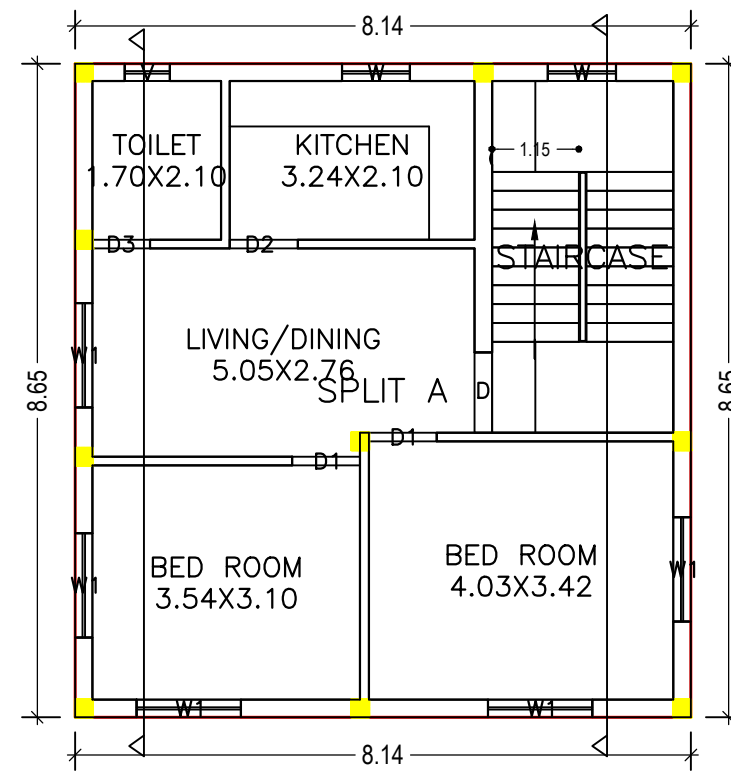

FIRST FLOOR PLAN
(Proposed)
(SCALE 1:100)

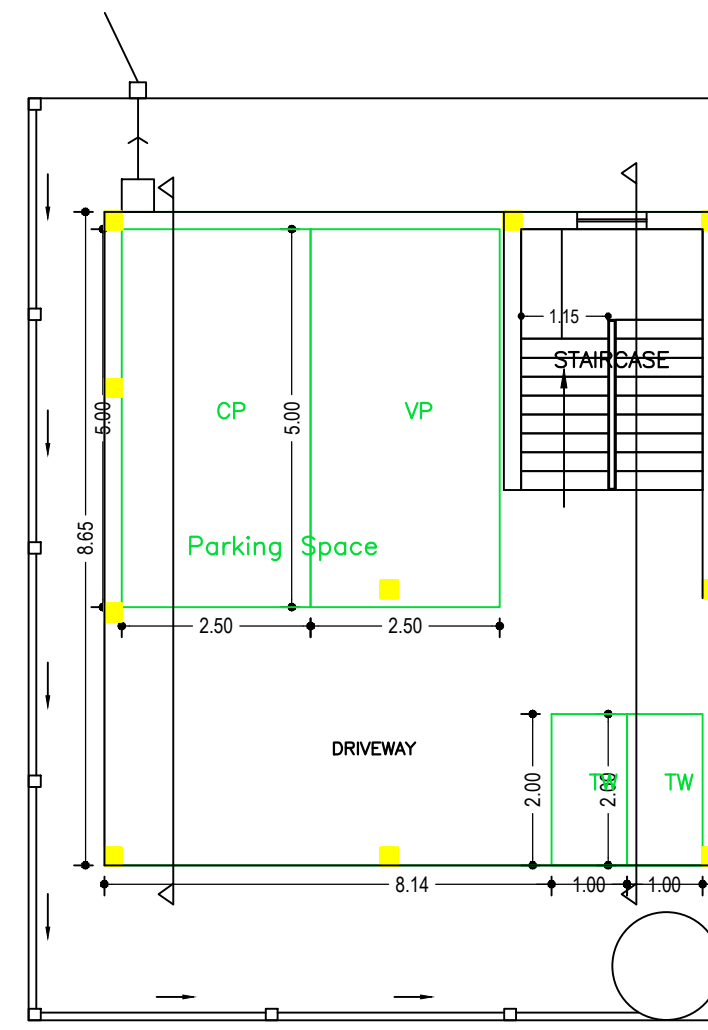

PARKING FLOOR PLAN
(SCALE 1:100)

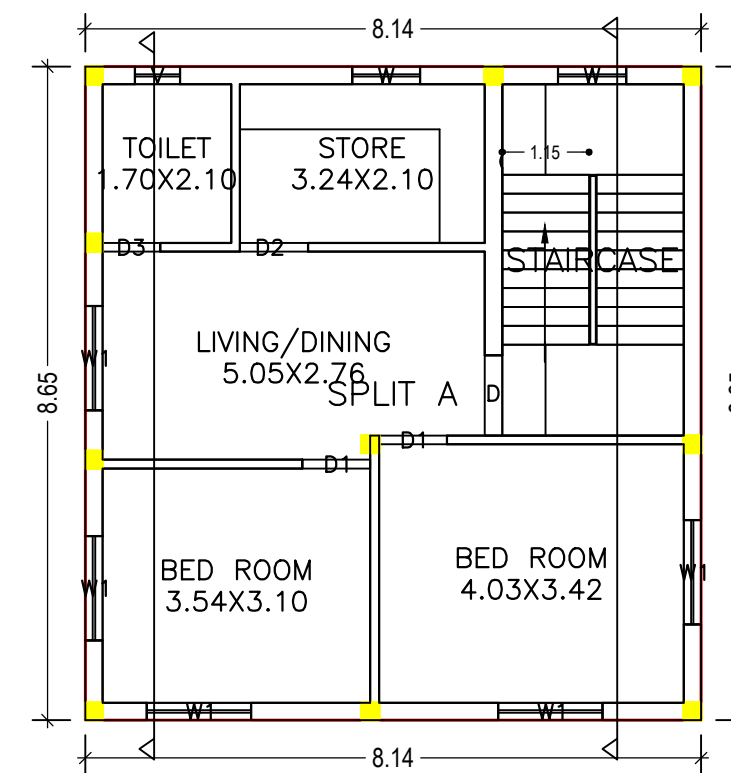

SECOND FLOOR PLAN
(Proposed)
(SCALE 1:100)

LTP NAME AND SIGNATURE	STRUCTURAL ENG'S NAME AND SIGNATURE	BUILDER NAME AND SIGNATURE	DIGITAL SIGNATURE
L K Suman JNAC/ENG/0006/2016			

Proposal Basic Information

Proposal File No.	JNAC/BP/0017/W3/2020
Owner Name	Sri Shailendra Kr. Singh and Others
Khata No	Nil
Plot No	32-A Ranikudar West Area
Village Name	KADMA
Use	Residential
SubUse	Bungalow/ Dwelling / Non Apartment

Building :A (SHAIENDRA KUMAR SINGH AND OTHERS)

Floor Name	Total Built Up Area (Sq.mt.)	Deductions (Area in Sq.mt.)			Proposed FAR Area (Sq.mt.)	Add Area In FAR (Sq.mt.)	Total FAR Area (Sq.mt.)	Total Consumed Additional FAR Area (Sq.mt.)	Tnmt (No.)
		Parking	Resi.	Stair					
Parking Floor	70.41	62.13	0.00	8.28	8.28	8.28	0.00	00	
First Floor	70.41	0.00	70.41	0.00	70.41	70.41	0.00	01	
Second Floor	70.41	0.00	70.41	0.00	70.41	70.41	0.00	00	
Terrace Floor	0.00	0.00	0.00	0.00	0.00	0.00	0.00	00	
Total :	211.23	62.13	140.82	8.28	149.10	149.10	0.00	01	
Total Number of Same Buildings	1								
Total :	211.23	62.13	140.82	8.28	149.10	149.10	0.00	01	

SCHEDULE OF DOOR:

BUILDING NAME	NAME	LENGTH	HEIGHT	NOS
A (SHAIENDRA KUMAR SINGH AND OTHERS)	D3	0.76	2.10	02
A (SHAIENDRA KUMAR SINGH AND OTHERS)	D2	0.90	2.10	02
A (SHAIENDRA KUMAR SINGH AND OTHERS)	D1	0.90	2.10	04
A (SHAIENDRA KUMAR SINGH AND OTHERS)	D	1.06	2.10	02

SCHEDULE OF WINDOW/VENTILATION:

BUILDING NAME	NAME	LENGTH	HEIGHT	NOS
A (SHAIENDRA KUMAR SINGH AND OTHERS)	V	0.60	0.60	02
A (SHAIENDRA KUMAR SINGH AND OTHERS)	W	0.90	1.20	04
A (SHAIENDRA KUMAR SINGH AND OTHERS)	W1	1.38	1.20	10

UnitBUA Table for Building :A (SHAIENDRA KUMAR SINGH AND OTHERS)

FLOOR	Name	UnitBUA Type	UnitBUA Area	Carpet Area	No. of Rooms	No. of Tenement
FIRST FLOOR PLAN	SPLIT A	FLAT	140.83	125.03	5	1
SECOND FLOOR PLAN	SPLIT A	FLAT	0.00	0.00	5	0
Total:	-	-	140.83	125.03	10	1

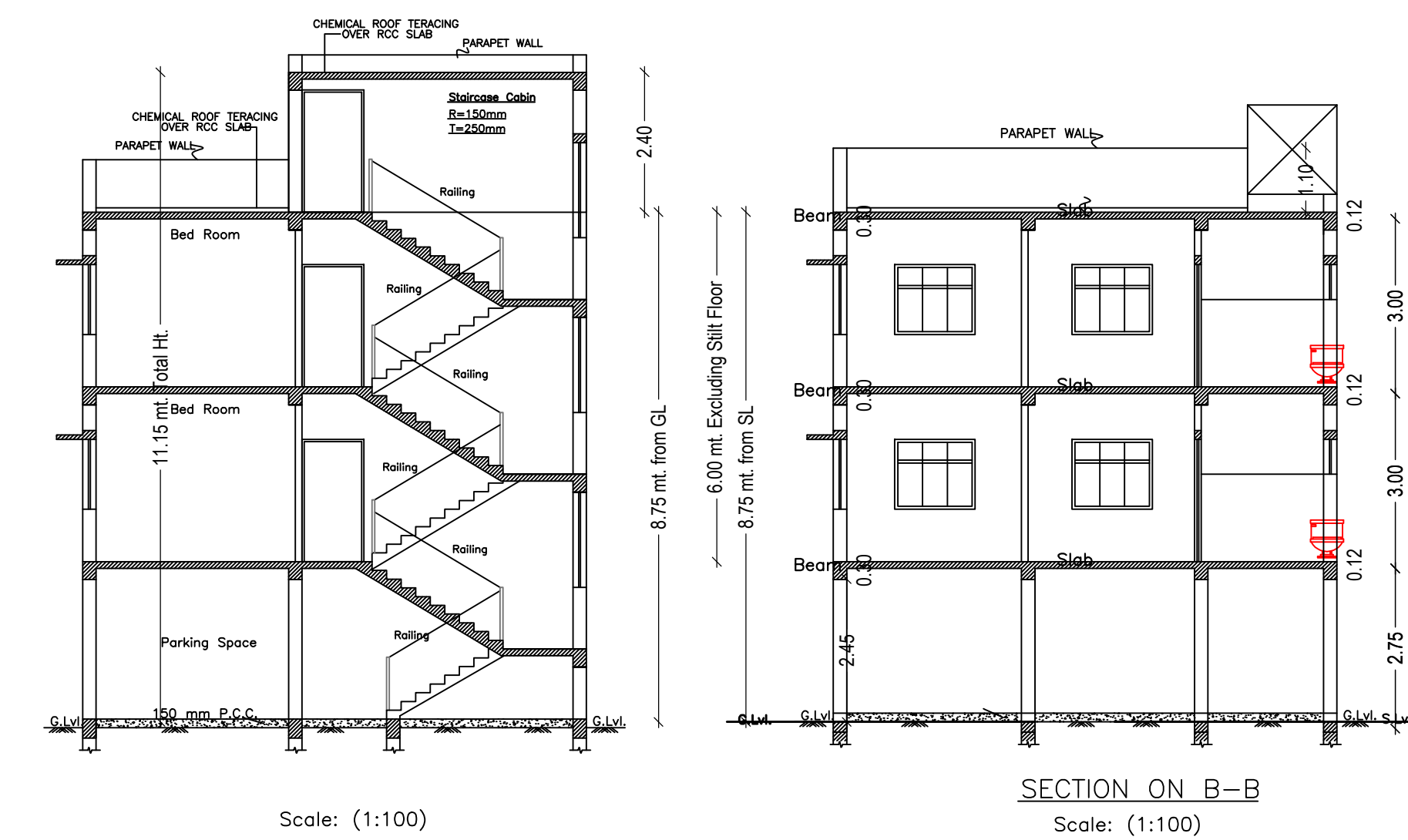

LTP NAME AND SIGNATURE	STRUCTURAL ENG'S NAME AND SIGNATURE	BUILDER NAME AND SIGNATURE	DIGITAL SIGNATURE
L K Suman JNAC/ENG/0006/2016			

Proposal Basic Information	
Proposal File No.	JNAC/BP/0017/W3/2020
Owner Name	Sri Shailendra Kr. Singh and Others
Khata No	Nil
Plot No	32-A Ranikudar West Area
Village Name	KADMA
Use	Residential
SubUse	Bungalow/ Dwelling / Non Apartment

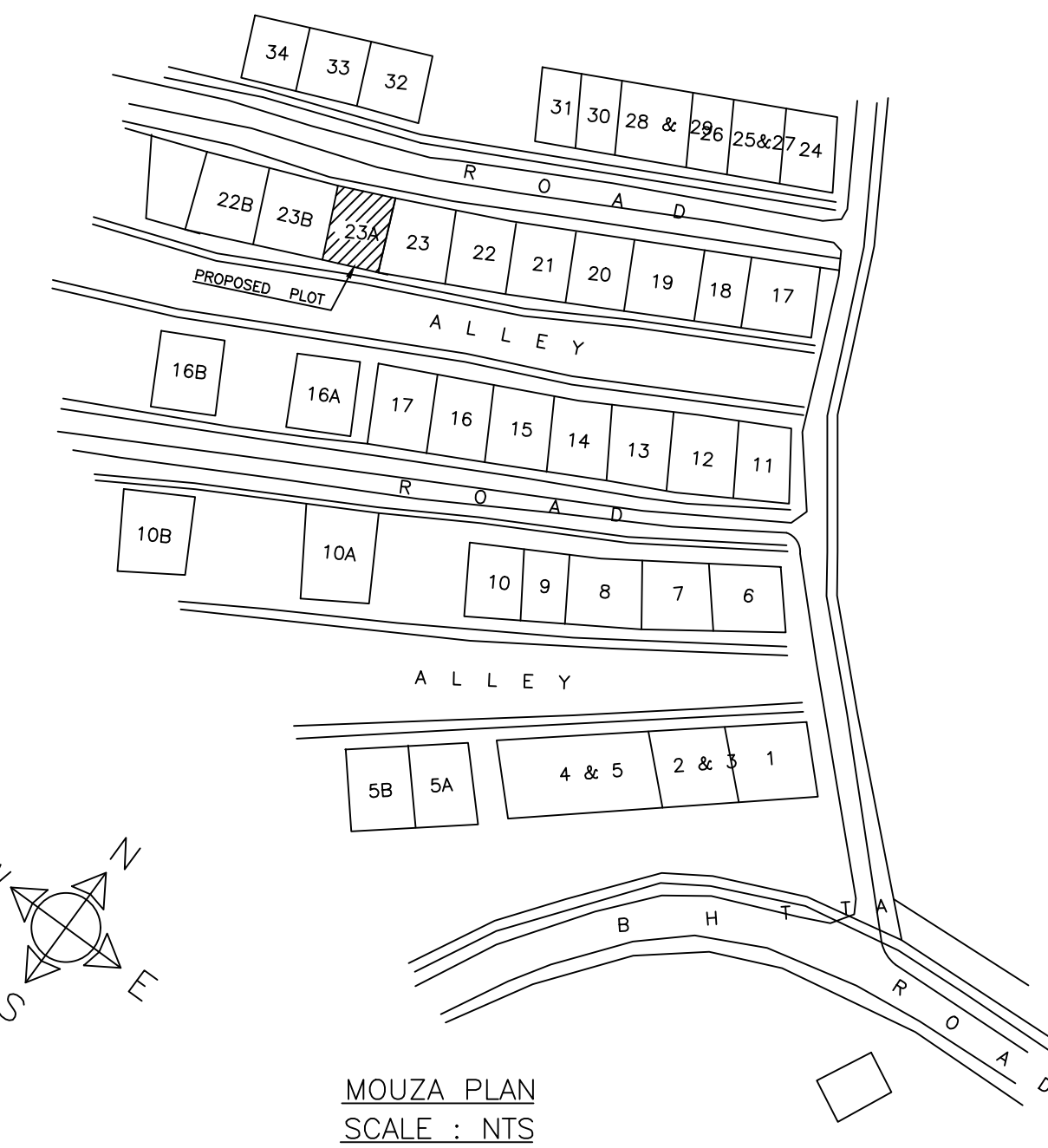
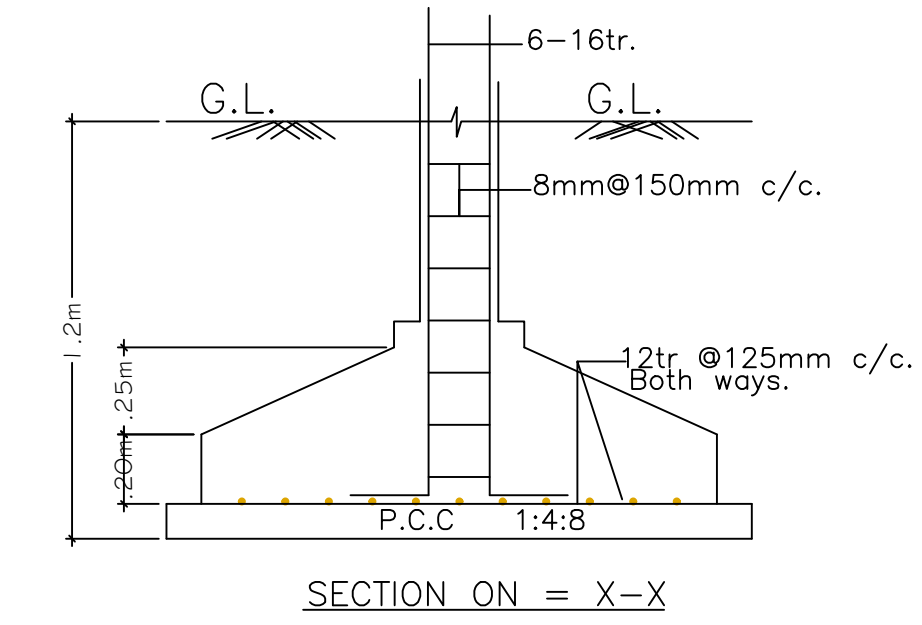
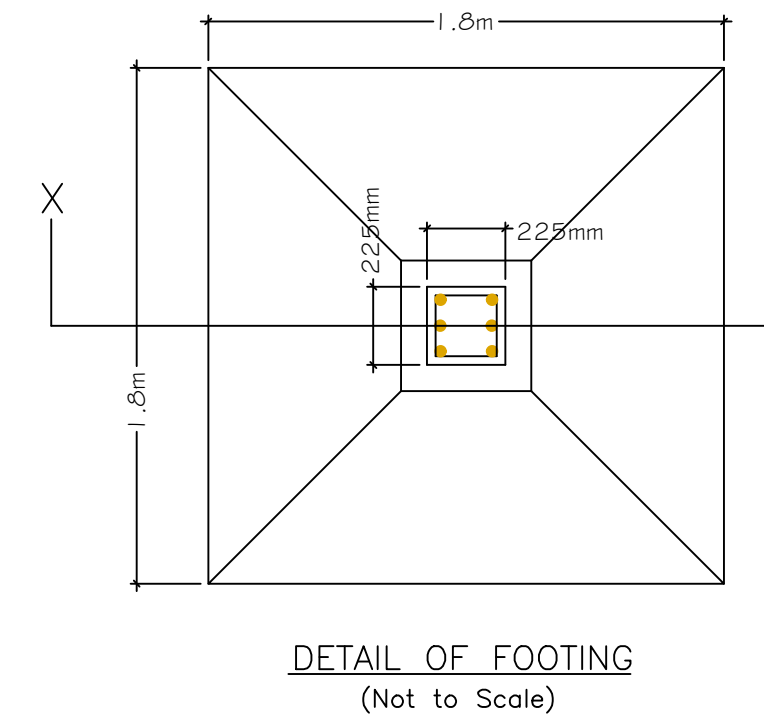
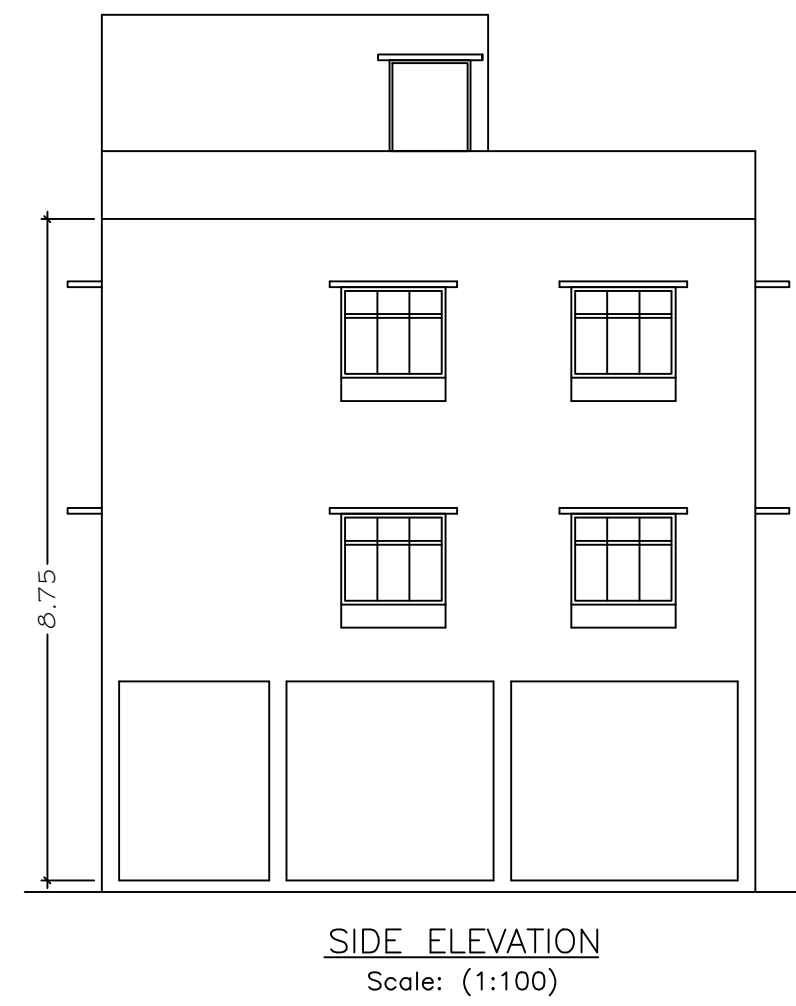
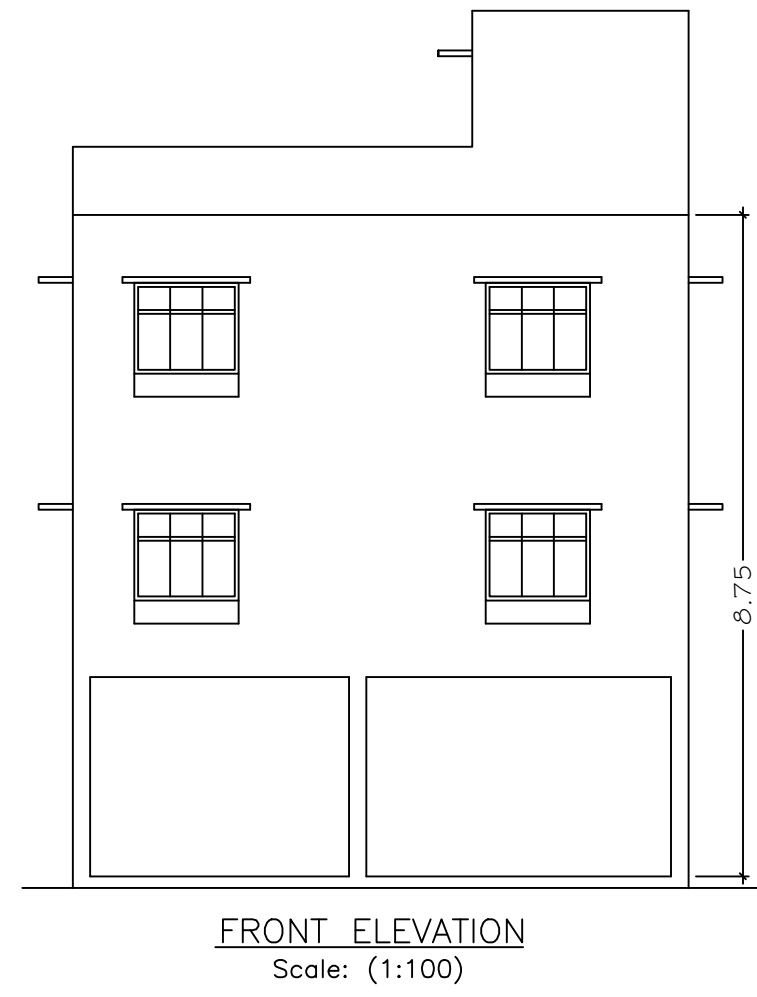

PART SITE PLAN RANIKUDAR WEST AREA
SCALE : NTS

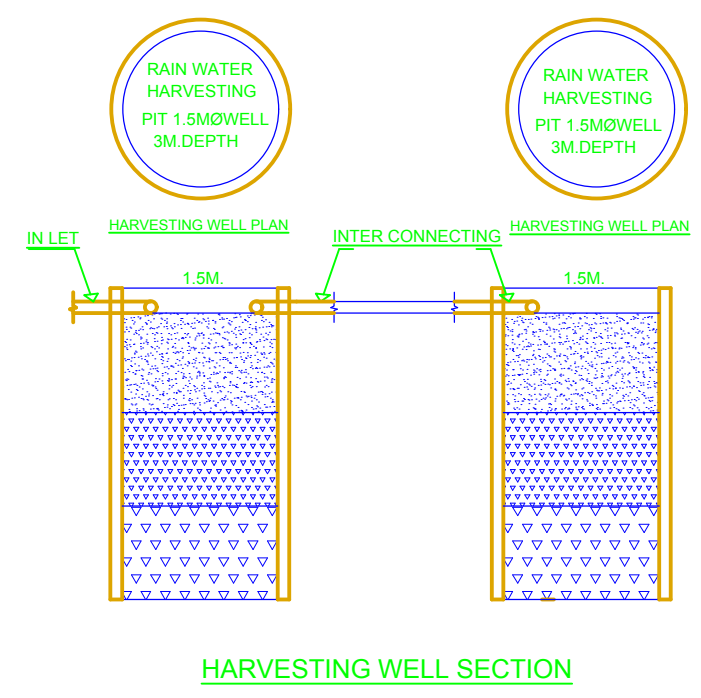

LTP NAME AND SIGNATURE	STRUCTURAL ENG'S NAME AND SIGNATURE	BUILDER NAME AND SIGNATURE	DIGITAL SIGNATURE
L K Suman JNAC/ENG/0006/2016			