

SITE PLAN (Scale - 1:200)

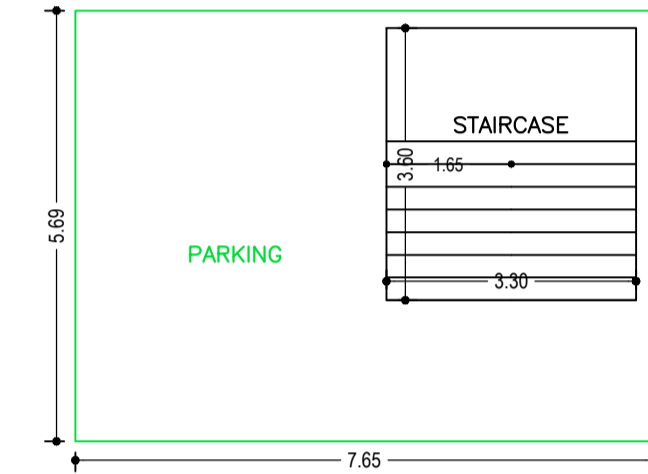

STILT FLOOR PLAN (SCALE 1:100)

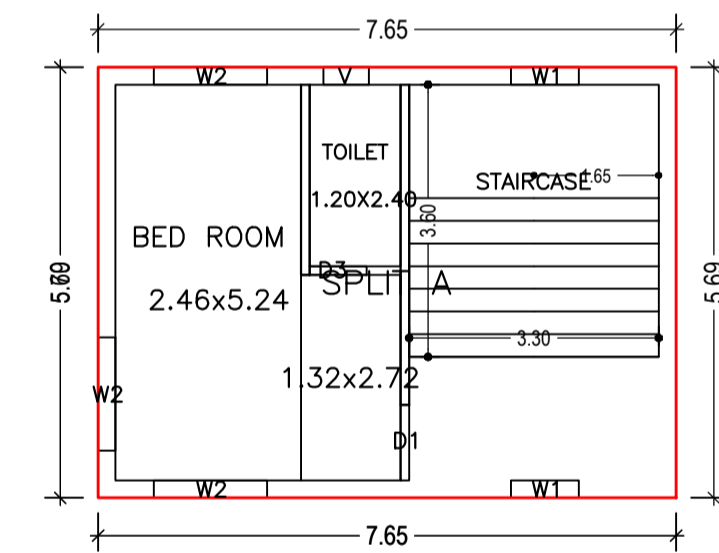

FIRST FLOOR PLAN (Proposed) (SCALE 1:100)

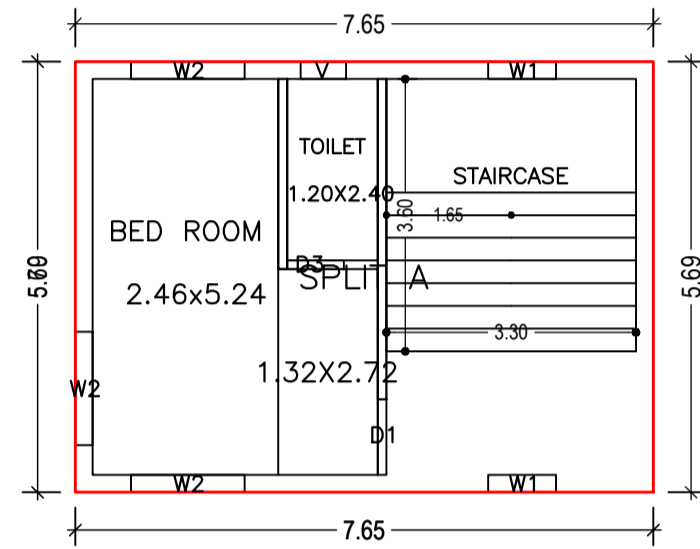

SECOND FLOOR PLAN (Proposed) (SCALE 1:100)

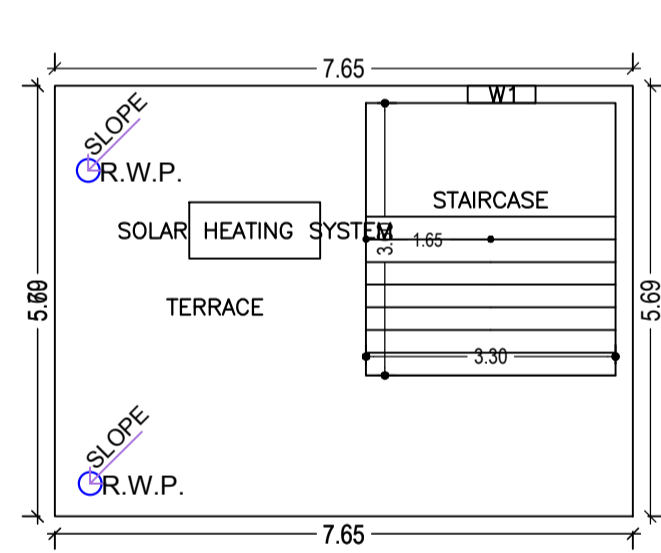

TERRACE FLOOR PLAN (SCALE 1:100)

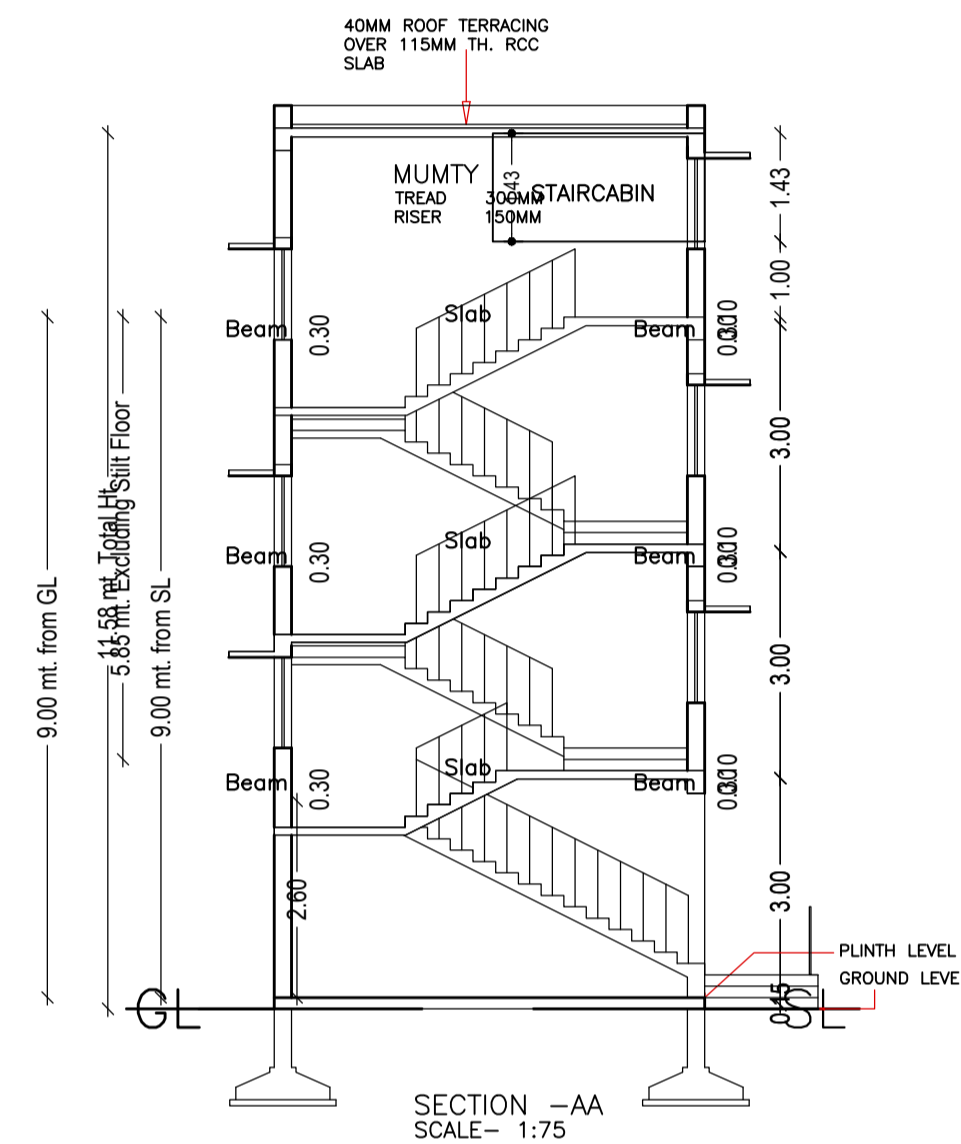

SECTION -AA SCALE- 1:75

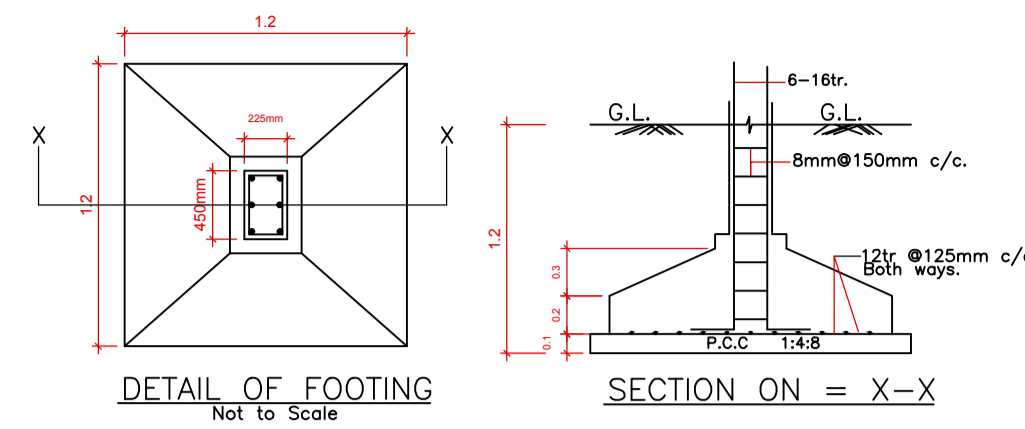

DETAIL OF FOOTING Not to Scale  
SECTION ON = X-X

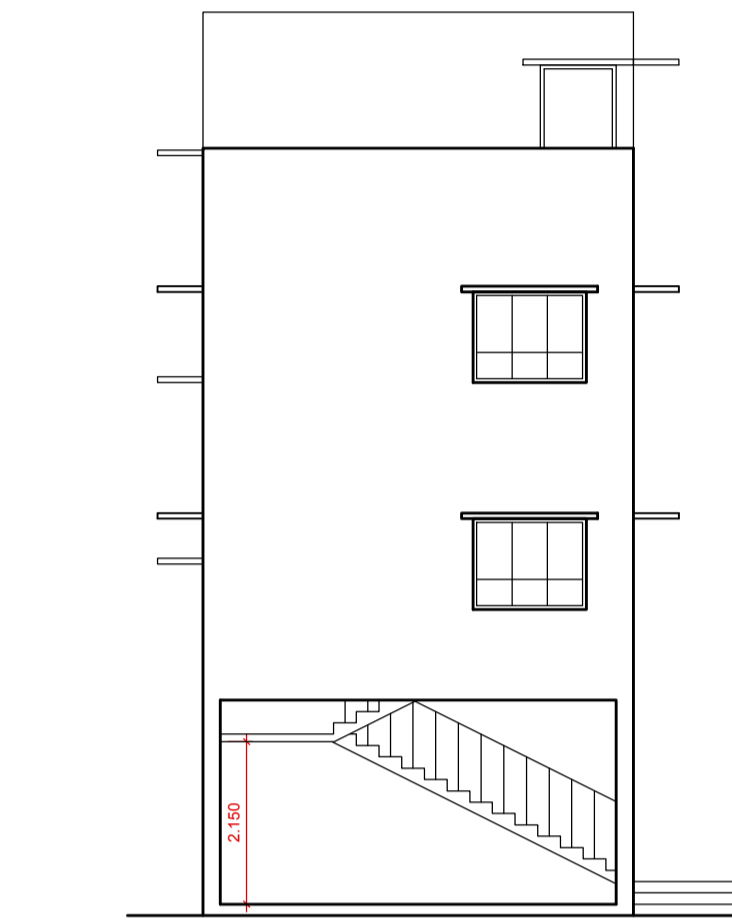

SIDE ELEVATION SCALE- 1:75

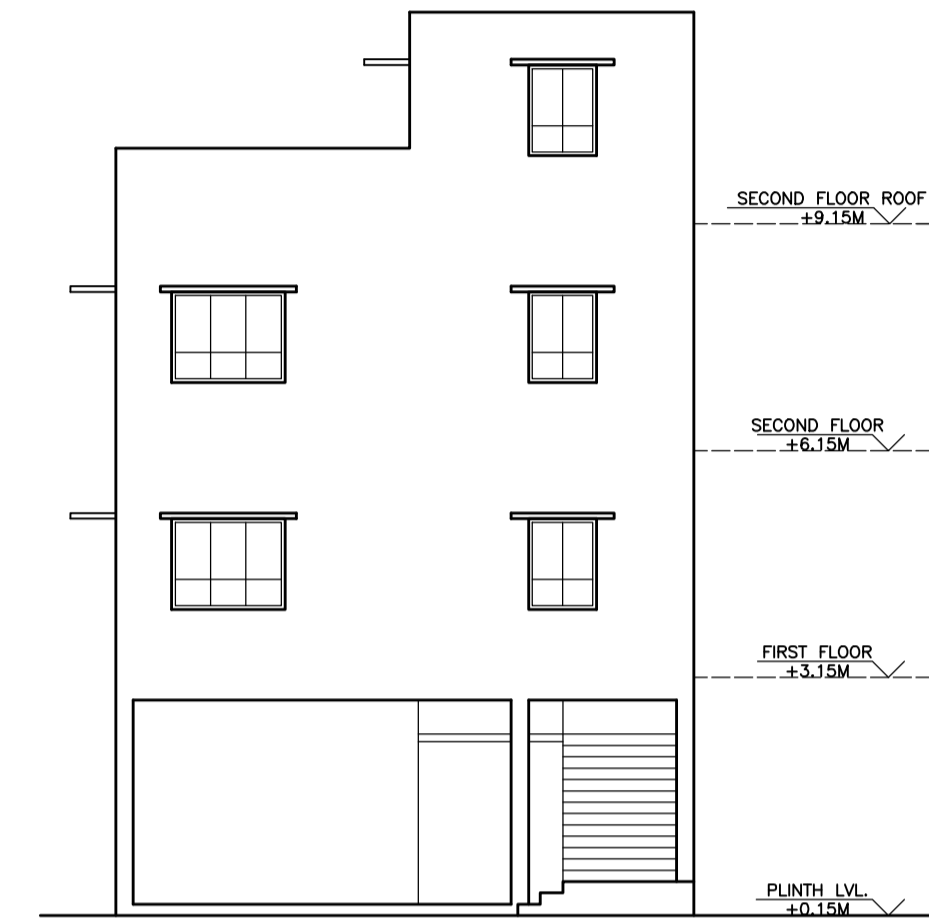

FRONT ELEVATION SCALE- 1:75

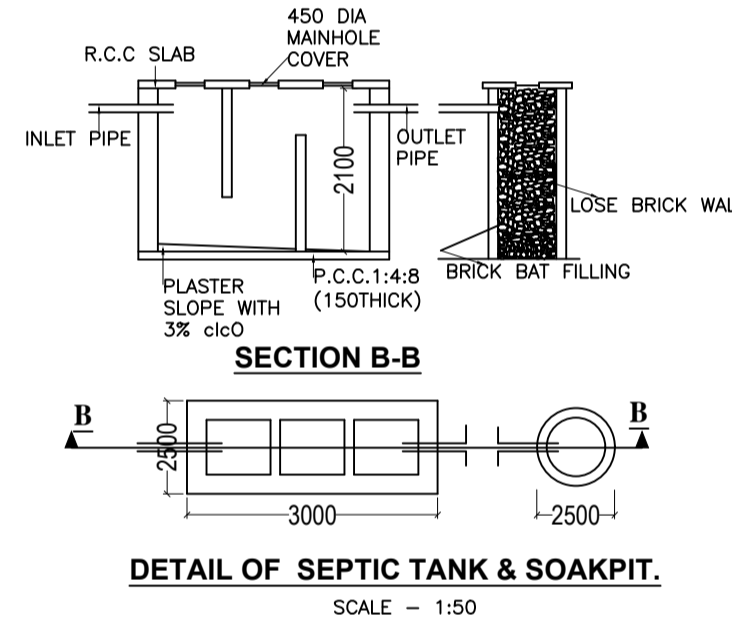

DETAIL OF SEPTIC TANK & SOAKPIT. SCALE - 1:50

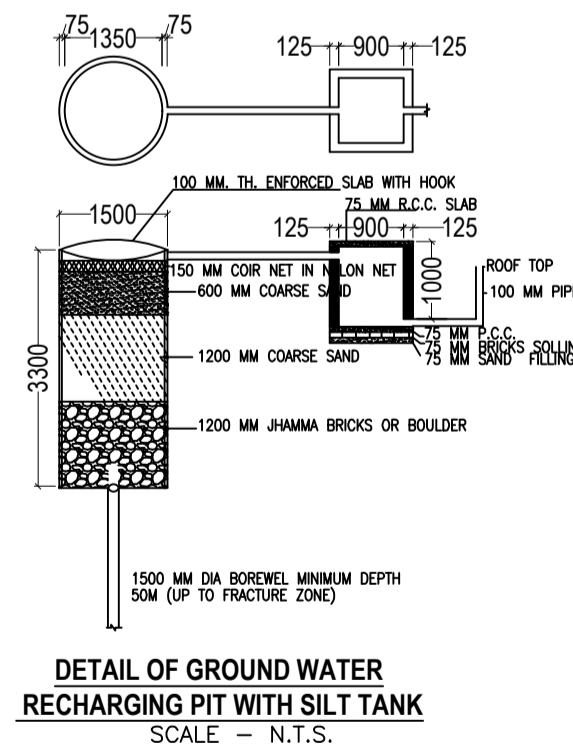

DETAIL OF GROUND WATER RECHARGING PIT WITH SILT TANK SCALE - N.T.S.

FAR & Tenement Details (Table 4c-1)

Building	No. of Same Bldg	Total Built Up Area (Sq.mt.)	Deductions (Area in Sq.mt.)	Proposed FAR Area (Sq.mt.)	Add Area In FAR (Sq.mt.)	Total FAR Area (Sq.mt.)	Total Consumed Additional FAR Area (Sq.mt.)	Tnmt (No.)
PROPOSED (BUILDING)	1	130.62	31.66	87.08	11.88	98.96	98.96	01
Grand Total :	1	130.62	31.66	87.08	11.88	98.96	98.96	01

Proposal Basic Information	
Proposal File No.	JNAC/BP/0075/W12/2020
Owner Name	PRAVESH KUMAR JAGGI
Khata No	61
Plot No	2926
Village Name	GOLMURI
Use	Residential
SubUse	Bungalow/ Dwelling / Non Apartment

AREA STATEMENT JAMSHEDPUR NAC		VERSION NO. : 1.0.51
PROJECT DETAIL:		VERSION DATE: 16/10/2020
Region: JHARKHAND URBAN LOCAL BODIES	Plot Use: Residential	
District: EAST SINGHBHUM	Plot SubUse: Bungalow/ Dwelling / Non Apartment	
Authority: JAMSHEDPUR NAC	PlotNearby/Religious/Structure: NA	
Inward_No: JNAC/BP/0075/W12/2020	Plot/SubPlot No: 2926	
Application Type: General Proposal	North: Plot No. - 11	
Project Type: Building Permission	South: Plot No. - 13	
Nature of Development: New	East: Road Width - 6.1	
Location of Development Area: Old Area	West: Road Width - 3.6	
<b>AREA DETAILS:</b>		
AREA OF PLOT (Minimum)	(A)	111.31
NET AREA OF PLOT(Gross Plot Area - Deduction from Gross Plot area)	(A-Deductions)	111.31
Deduction for Balance Plot Area(from Gross Plot Area)		
Common Plot		15.07
Total		15.07
BALANCE AREA OF PLOT(Net Plot Area - Recreational/Amenity space)	(A-Deductions)	96.23
PLOT AREA FOR COVERAGE(Net Plot Area)	(A-Deductions)	111.31
Plot Area for FAR (Net Plot Area + Road Widening Area)	(A-Deductions)	111.31
<b>COVERAGE CHECK</b>		
Permissible Coverage area ( 70.00 % )		77.92
Proposed Coverage Area ( 39.12 % )		43.54
Total Prop. Coverage Area ( 39.12 % )		43.54
Balance coverage area ( 30.89 % )		34.38
<b>FAR CHECK</b>		
Perm. FAR Area ( 2.50 )		278.27
Total Perm. FAR area		278.27
Residential FAR		87.09
Proposed FAR Area		98.97
Total Proposed FAR Area		98.97
Consumed FAR (Factor)		0.89
Balance FAR Area		179.30
<b>BUILT UP AREA CHECK</b>		
Total Proposed BuiltUp Area		130.62
ARCHITECT (Regd)		Amarjeet Balmuchu
ENGINEER (Regd)		
SUPERVISOR (Regd)		
OWNER (Regd)		PRAVESH KUMAR JAGGI
DEVELOPMENT AUTHORITY		LOCAL BODY

COLOR INDEX	
PLOT BOUNDARY	Black
ABUTTING ROAD	Green
PROPOSED CONSTRUCTION	Red
COMMON PLOT	Yellow
ROAD WIDENING AREA	Blue
EXISTING (To be retained)	Light Blue
EXISTING (To be demolished)	Light Yellow

Buildingwise Floor FAR Details

Floor Name	Building Name PROPOSED (BUILDING)		Total	
	Proposed Built Up Area (Sq.mt.)	Proposed FAR Area (Sq.mt.)	Total Proposed Built Up Area (Sq.mt.)	Total FAR Area (Sq.mt.)
Stilt Floor	43.54	11.88	43.54	11.88
First Floor	43.54	43.54	43.54	43.54
Second Floor	43.54	43.54	43.54	43.54
Terrace Floor	0.00	0.00	0.00	0.00
Total :	130.62	98.96	130.62	98.96

Building USE/SUBUSE Details

Building Name	Building Use	Building SubUse	Building Structure
PROPOSED (BUILDING)	Residential	Bungalow/ Dwelling / Non Apartment	Non-Highrise

Building :PROPOSED (BUILDING)

Floor Name	Total Built Up Area (Sq.mt.)	Deductions (Area in Sq.mt.)	Proposed FAR Area (Sq.mt.)	Add Area In FAR (Sq.mt.)	Total FAR Area (Sq.mt.)	Total Consumed Additional FAR Area (Sq.mt.)	Tnmt (No.)
Stilt Floor	43.54	31.66	0.00	11.88	11.88	11.88	00
First Floor	43.54	0.00	43.54	0.00	43.54	43.54	01
Second Floor	43.54	0.00	43.54	0.00	43.54	43.54	00
Terrace Floor	0.00	0.00	0.00	0.00	0.00	0.00	00
Total :	130.62	31.66	87.08	11.88	98.96	98.96	01
Total Number of Same Buildings	1						
Total :	130.62	31.66	87.08	11.88	98.96	98.96	01

SCHEDULE OF DOOR:

BUILDING NAME	NAME	LENGTH	HEIGHT	NOS
PROPOSED (BUILDING)	D3	0.75	2.10	02
PROPOSED (BUILDING)	D1	1.00	2.10	02

SCHEDULE OF WINDOW/VENTILATION:

BUILDING NAME	NAME	LENGTH	HEIGHT	NOS
PROPOSED (BUILDING)	V	0.60	1.20	02
PROPOSED (BUILDING)	W1	0.90	1.20	03
PROPOSED (BUILDING)	W2	1.50	1.20	06

UnitBUA Table for Building :PROPOSED (BUILDING)

FLOOR	Name	UnitBUA Type	UnitBUA Area	Carpet Area	No. of Rooms	No. of Tenement
FIRST FLOOR PLAN	SPLIT A	FLAT	75.24	73.68	2	1
SECOND FLOOR PLAN	SPLIT A	FLAT	0.00	0.00	2	0
Total:	-	-	75.24	73.68	4	1

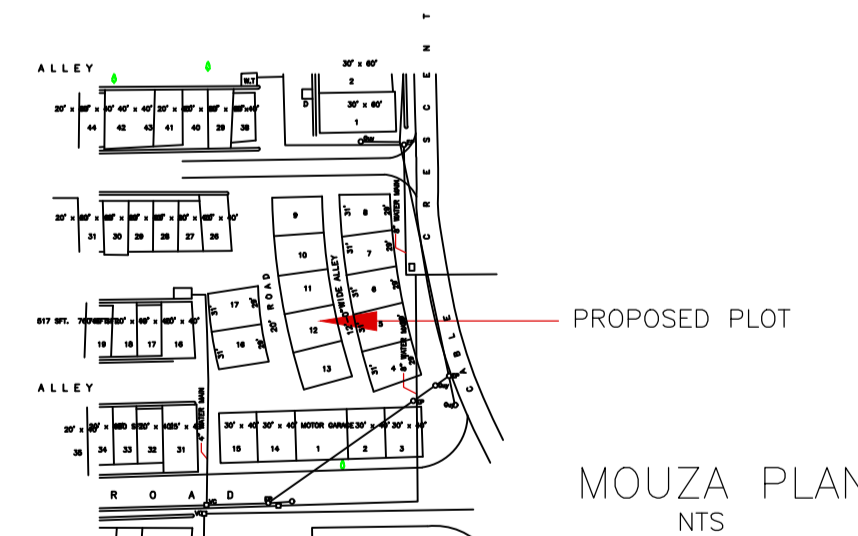

MOUZA PLAN NTS

LTP NAME AND SIGNATURE	STRUCTURAL ENG'S NAME AND SIGNATURE	BUILDER NAME AND SIGNATURE	DIGITAL SIGNATURE
Amarjeet Balmuchu JNAC/ARC/0008/2018			