

Project Title :SMT. TEJ SINGH AND SRI ABHAY SINGH

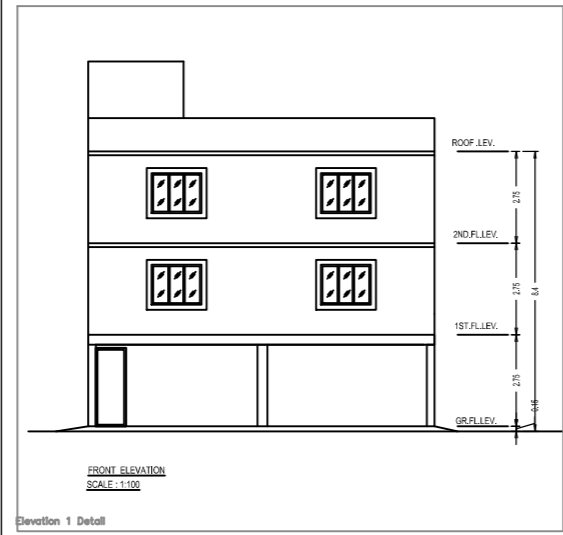

Detail 1 Detail

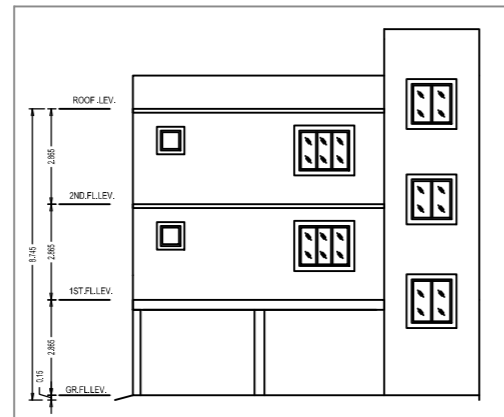
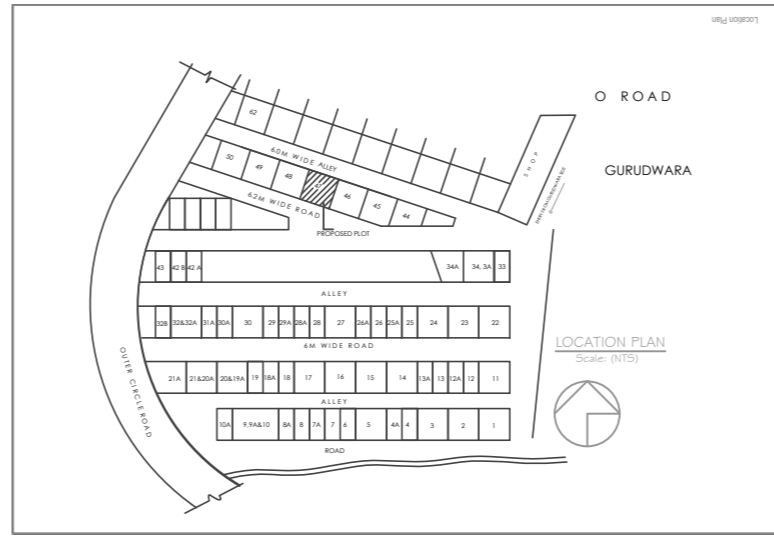
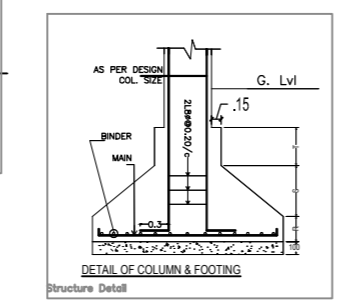
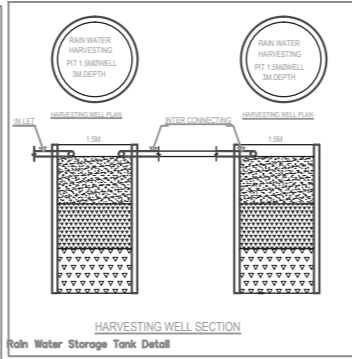

Detail 2 Detail

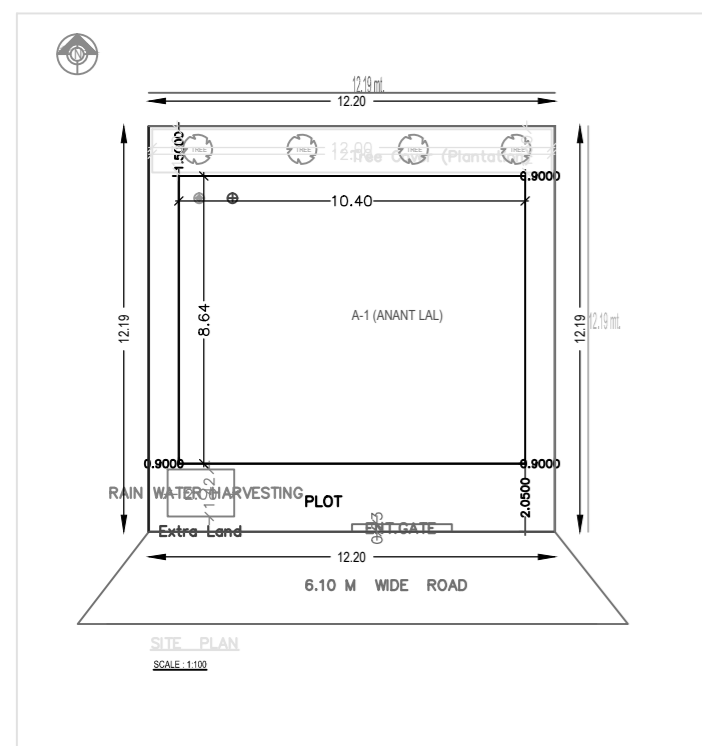
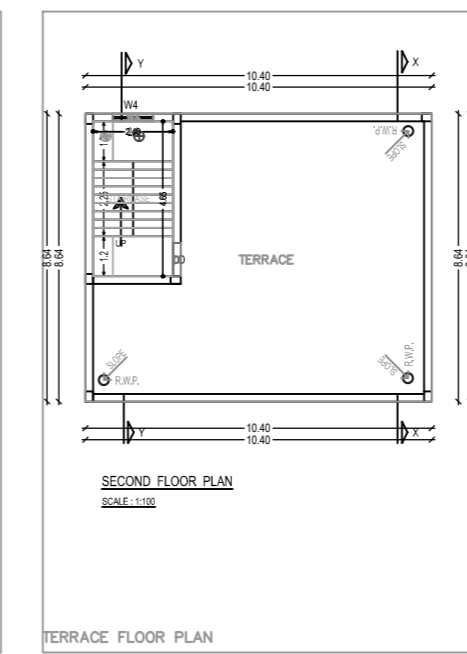
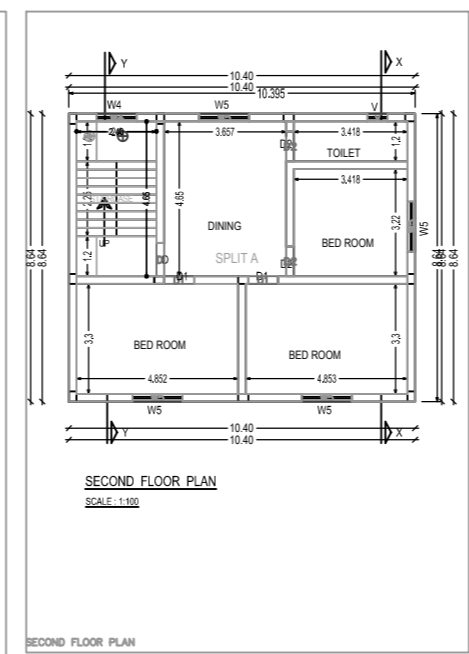
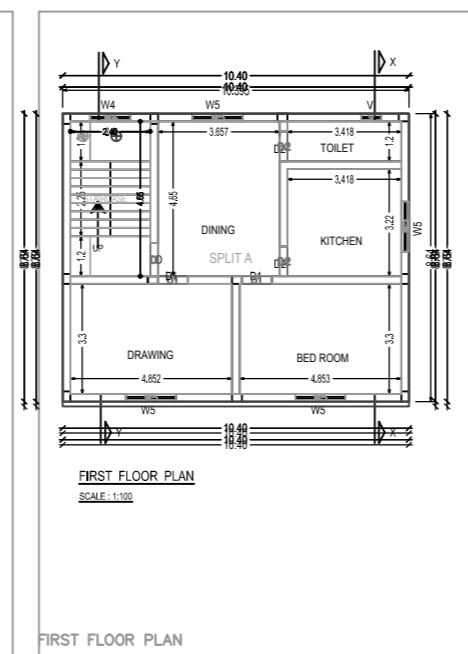
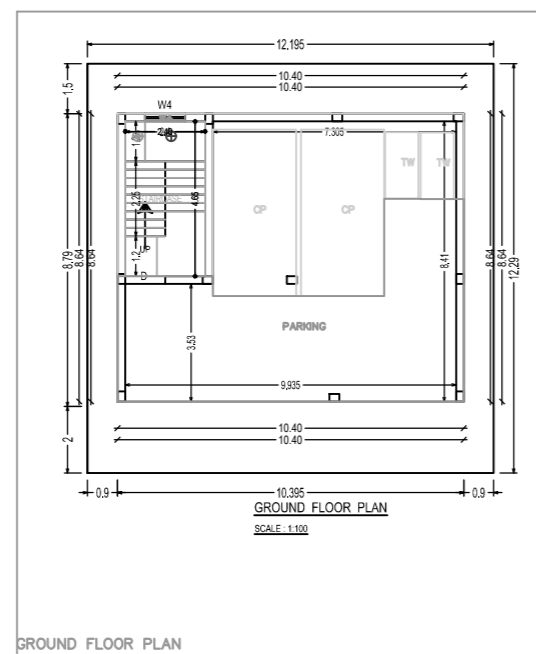
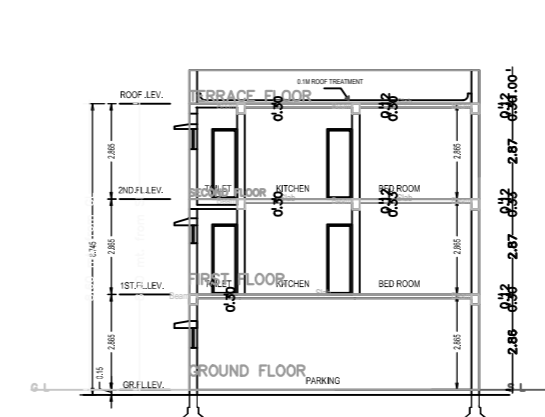
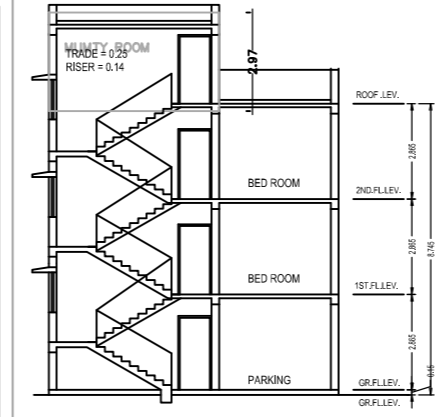
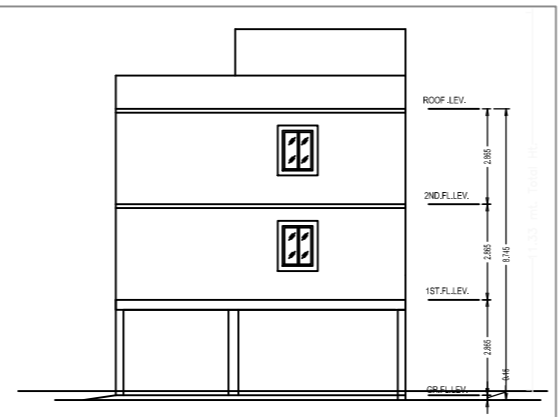

- NOTE:**
1. FOUNDATION & R.C.C. AS PER STRUCTURAL ENGG. SPECIFICATION
 2. ALL EXISTING STRUCTURE TO BE DEMOLISHED
 3. ALL DIMENSIONS IN Mts.
 4. DRAWING NOT TO BE SCALED

OFFICE USE

APPROVED:-

SPL.OFFICER,J.N.A.C., JAMSHEDPUR

OWNER / POAH

Signature of Applicant:-

GENERAL SPECIFICATION :-

- FOUNDATION :- PLAIN CEMENT CONCRETE AS PER DESIGN
- R.C.C. COLUMN FOOTING & COLUMN AS PER STRUCTURAL DESIGN
- R.C.C. COLUMN & BEAM AS PER STR. DESIGN
- SUPER STRUCTURE :- 5.23M THK EXT. WALL & 0.125M THK PARTITION WALL IN CEMENT MORTAR
- R.C.C. ROOF SLAB AS PER STRUCTURAL DESIGN
- FLOOR :- CERAMIC TILES FLOOR AND DADO
- INTERNAL FINISH :- CEMENT PLASTER WITH P.O.P. & O.D.
- SANITARY :- VITRIOUS CHINA CLAY SANITARY WARE G.I. PIPE WATER SUPPLY.
- P.V.C. PIPE FOR SEWAGE DISPOSAL
- AS PER SCHEDULE
- DOORS & WINDOW :- COPPER WIRE WITH P.V.C. CONDUIT.

PROPOSED RESIDENTIAL BUILDING PLAN OF ANANT LAL HOLDING NO.-147 GURUDAWARA BUSTEE AREA BISTUPUR JAMSHEDPUR

L.K. SUMAN

SHEET No- 01 / 01

L.K. SUMAN
Officr - 1, Second Floor
Suman Taksar Complex,
Sector, Jamshedpur

Reg. No.- JNAC/001(T)/2016

PROJECT DETAIL:		VERSION NO. 1.0.20					
VERSION DATE: 16/02/2020							
Empire No. :-	Plot Use - Residential						
Region - JHARKHAND URBAN LOCAL BODIES	Plot Subtype - Bungalow/ Dwelling / Non Apartment						
Project - EAST JHARKHAND	Land Use Zone - M4						
Application Type - General Provision	Abutting Road Width -						
Project Type - Building Permission	Plot No. :-						
Notice of Development - New	Revenue Survey No/Survey No -						
Location - CH Area	Thana No. :-						
Plot Location - New	Plotting No. :-						
Project/Block Name -	Plot No. :-						
Ward No. :-	North -						
Workorder :-	South -						
	East -						
	West -						
AREA DETAILS:							
AREA OF PLOT (Minimum)	(A)	148.86					
Net PIG Area (Gross Plot Area)	(A-Deductions)	148.86					
Deductions from Gross Plot Area	(A-Deductions)						
Deductions for Balance Plot Area (from Gross Plot Area)							
G.O.P. Area		15.59					
GP		15.59					
Balance Plot Area (Net PIG Area - Recreational/Amenity spaces)	(A-Deductions)	133.06					
Plot Area for Coverage (Net Plot Area)	(A-Deductions)	148.86					
Plot Area for PIG (Net PIG Area + Recreational/Amenity Area)	(A-Deductions)	148.86					
COVERAGE CHECK							
Proposed Coverage Area (G.C.F. %)		88.81					
Total Coverage Area (G.C.F. %)		88.81					
FAR CHECK							
Proposed Area of FAR		182.34					
Total Area of FAR		182.34					
BUILD UP AREA CHECK							
Total Proposed Building Area		270.99					
ARCHT ENGR / SUPERVISOR (Stamp)	OWNER						
DEVELOPMENT AUTHORITY							
LOCAL BODY							
COLOR INDEX							
PLOT BOUNDARY							
ABUTTING ROAD							
PROPOSED WORK (COVERAGE AREA)							
EXISTING (To be retained)							
EXISTING (To be demolished)							
Color Index:							
PARKING CALCULATION:							
Car Parking	Prop No.	Prop Area					
Two Wheeler Parking	2	25.00					
Motor Parking	2	4.00					
Total Area	4	49.00					
	5	78.85					
MARGIN DETAIL:							
Building / Wing	Road Name	Front Margin	Rear Margin	Side Margin	Side Margin		
A-1 (ANANT LAL)	6.10 M WIDE ROAD	2.00	1.50	0.90	0.90		
FAR & Tenement Details (Table 4c-1)							
Building	No. of Same Bldg	Total Built Up Area (Sq.mt)	Deductions (Area in Sq.mt)	Proposed FAR Area (Sq.mt)	Add Area in FAR (Sq.mt)	Total FAR Area (Sq.mt)	Tent (No.)
A-1 (ANANT LAL)	1	270.99	78.85	181.18	11.16	192.34	01
Grand Total	1	270.99	78.85	181.18	11.16	192.34	01

Floor Name	Total Built Up Area (Sq.mt)	Deductions Area (Sq.mt)	Proposed FAR Area (Sq.mt)	Add Area in FAR (Sq.mt)	Total FAR Area (Sq.mt)	Tent (No.)
Ground Floor	89.81	0.00	89.81	0.00	89.81	00
First Floor	89.81	0.00	89.81	0.00	89.81	01
Second Floor	89.81	0.00	89.81	0.00	89.81	00
Terrace Floor	0.00	0.00	0.00	0.00	0.00	00
Total	270.99	78.85	181.18	11.16	192.34	01
Total Number of Same Buildings	1					
Total	270.99	78.85	181.18	11.16	192.34	01

Building Name	Name	Length	Height	No. of Joinery
A-1 (ANANT LAL)	D1	0.90	2.50	04
A-1 (ANANT LAL)	D1	0.90	2.50	04
A-1 (ANANT LAL)	D1	0.90	2.50	03
Total				11

Building Name	Name	Length	Height	No. of Joinery
A-1 (ANANT LAL)	V	0.90	1.50	02
A-1 (ANANT LAL)	WS	1.50	1.20	04
A-1 (ANANT LAL)	WS	1.50	1.20	08
Total				14

Floor	Name	Use/Type	UnBUA Area	Carpet Area	No. of Rooms	No. of Tenement
FIRST FLOOR PLAN	SPLIT A	FLAT	243.80	229.07	5	1
Total			243.80	229.07	5	1