

(Scale - 1:200)

FAR & Tenement Details (Table 4c-1)

Building	No. of Same Bldg	Total Built Up Area (Sq.mt.)	Deductions (Area in Sq.mt.)		Proposed FAR Area (Sq.mt.)	Add Area In FAR (Sq.mt.)	Total FAR Area (Sq.mt.)	Total Consumed Additional FAR Area (Sq.mt.)	Trmnt (No.)
			Parking	Resi.					
A (ANANT LAL)	1	270.99	78.65	181.18	11.16	192.34	192.34	01	
Grand Total :	1	270.99	78.65	181.18	11.16	192.34	192.34	01	

Proposal Basic Information

Proposal File No.	JNAC/BP/0077/W2/2020
Owner Name	Sri. Anant Lal POA Jaspal Singh
Khata No	Nil
Plot No	Ho. No-47, Gurudwara Bustee
Village Name	Bisthupur
Use	Residential
SubUse	Bungalow/ Dwelling / Non Apartment

AREA STATEMENT JAMSHEDPUR NAC		VERSION NO.: 1.0.53 VERSION DATE: 16/10/2020
PROJECT DETAIL:		
Region: JHARKHAND URBAN LOCAL BODIES	Plot Use: Residential	
District: EAST SINGHBHUM	Plot SubUse: Bungalow/ Dwelling / Non Apartment	
Authority: JAMSHEDPUR NAC	PlotNearbyReligiousStructure: NA	
Inward No: JNAC/BP/0077/W2/2020	Plot/SubPlot No: Ho. No-47, Gurudwara Bustee	
Application Type: General Proposal	North: Survey No. - alley	
Project Type: Building Permission	South: Road Width - 6.2	
Nature of Development: New	East: Plot No. - 48	
Location of Development Area: Old Area	West: Plot No. - 47	
AREA DETAILS:		
AREA OF PLOT (Minimum)	(A)	SQ.MT. 148.66
NET AREA OF PLOT(Gross Plot Area - Deduction from Gross Plot area)	(A-Deductions)	148.66
Deduction for Balance Plot Area(from Gross Plot Area)		
Common Plot		15.59
Total		15.59
BALANCE AREA OF PLOT(Net Plot Area - Recreational/Amenity space)	(A-Deductions)	133.06
PLOT AREA FOR COVERAGE(Net Plot Area)	(A-Deductions)	148.66
Plot Area for FAR (Net Plot Area + RoadWidening Area)	(A-Deductions)	148.66
COVERAGE CHECK		
Permissible Coverage area (70.00 %)		104.06
Proposed Coverage Area (60.41 %)		89.81
Total Prop. Coverage Area (60.41 %)		89.81
Balance coverage area (9.59 %)		14.25
FAR CHECK		
Perm. FAR Area (2.50)		371.65
Total Perm. FAR area		371.65
Residential FAR		181.18
Proposed FAR Area		192.34
Total Proposed FAR Area		192.34
Consumed FAR (Factor)		1.29
Balance FAR Area		179.31
BUILT UP AREA CHECK		
Total Proposed BuiltUp Area		270.99
ARCHITECT (Regd)	L K Suman	
ENGINEER (Regd)		
SUPERVISOR (Regd)		
OWNER (Regd)	Sri. Anant Lal POA Jaspal Singh	
DEVELOPMENT AUTHORITY		LOCAL BODY

COLOR INDEX	
PLOT BOUNDARY	Black
ABUTTING ROAD	Green
PROPOSED CONSTRUCTION	Red
COMMON PLOT	Yellow
ROAD WIDENING AREA	Orange
EXISTING (To be retained)	Blue
EXISTING (To be demolished)	Light Blue

Buildingwise Floor FAR Details

Floor Name	Building Name A (ANANT LAL)		Total	
	Proposed Built Up Area (Sq.mt.)	Proposed FAR Area (Sq.mt.)	Total Proposed Built Up Area (Sq.mt.)	Total FAR Area (Sq.mt.)
Ground Floor	89.81	11.16	89.81	11.16
First Floor	91.37	91.37	91.37	91.37
Second Floor	89.81	89.81	89.81	89.81
Terrace Floor	0.00	0.00	0.00	0.00
Total :	270.99	192.34	270.99	192.34

Building USE/SUBUSE Details

Building Name	Building Use	Building SubUse	Building Structure
A (ANANT LAL)	Residential	Bungalow/ Dwelling / Non Apartment	Non-Highrise

LTP NAME AND SIGNATURE	STRUCTURAL ENG'S NAME AND SIGNATURE	BUILDER NAME AND SIGNATURE	DIGITAL SIGNATURE
L K Suman JNAC/ENG/0006/2016			

Proposal Basic Information	
Proposal File No.	JNAC/BP/0077/W2/2020
Owner Name	Sri. Anant Lal POA Jaspal Singh
Khata No	Nil
Plot No	Ho. No-47, Gurudwara Bustee
Village Name	Bisthupur
Use	Residential
SubUse	Bungalow/ Dwelling / Non Apartment

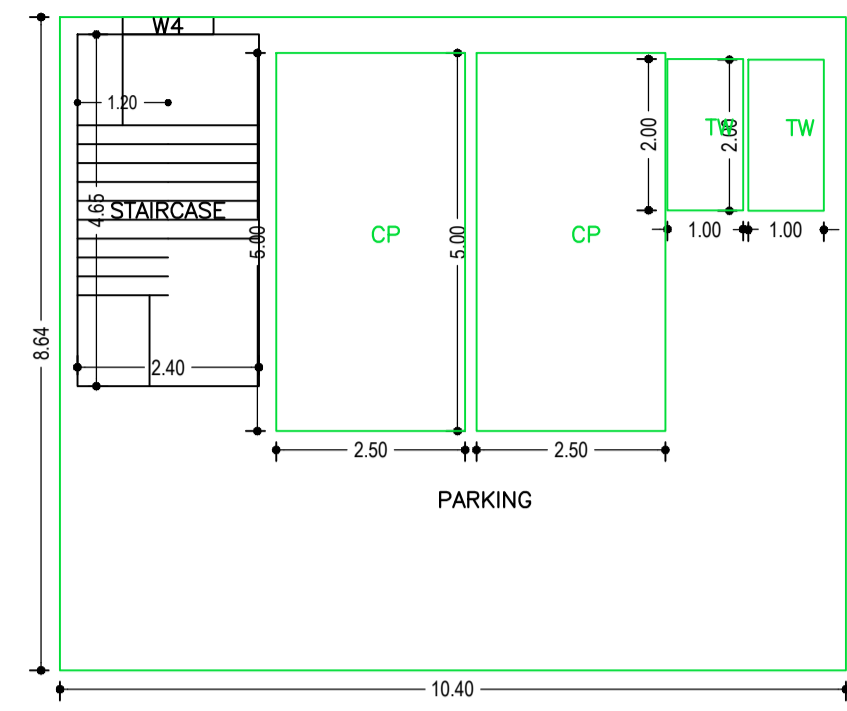

GROUND FLOOR PLAN (SCALE 1:100)

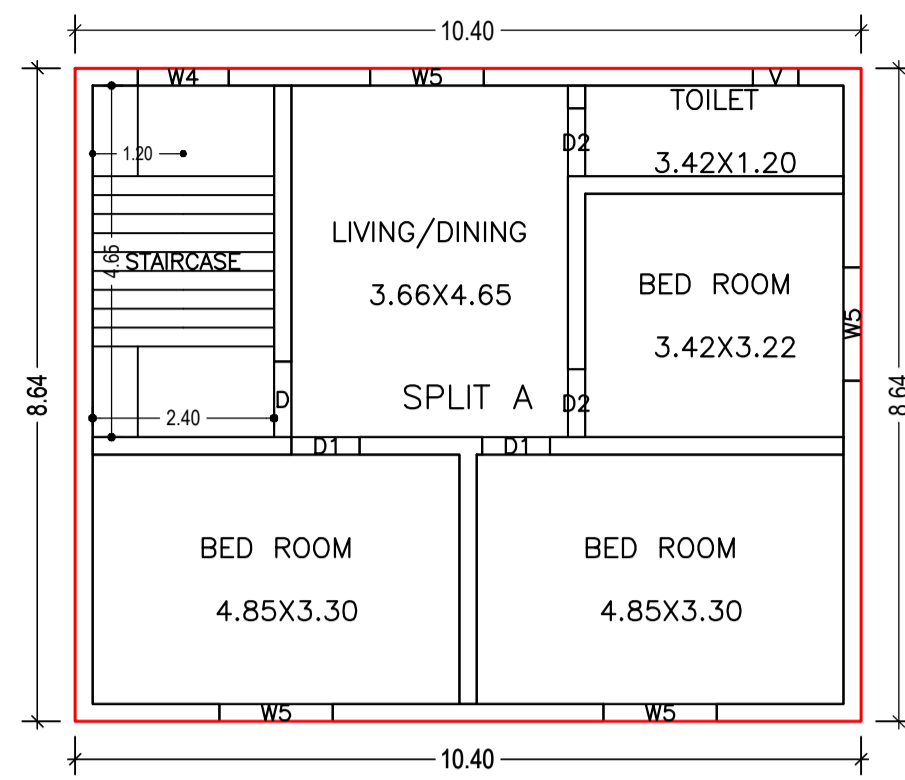

SECOND FLOOR PLAN (Proposed) (SCALE 1:100)

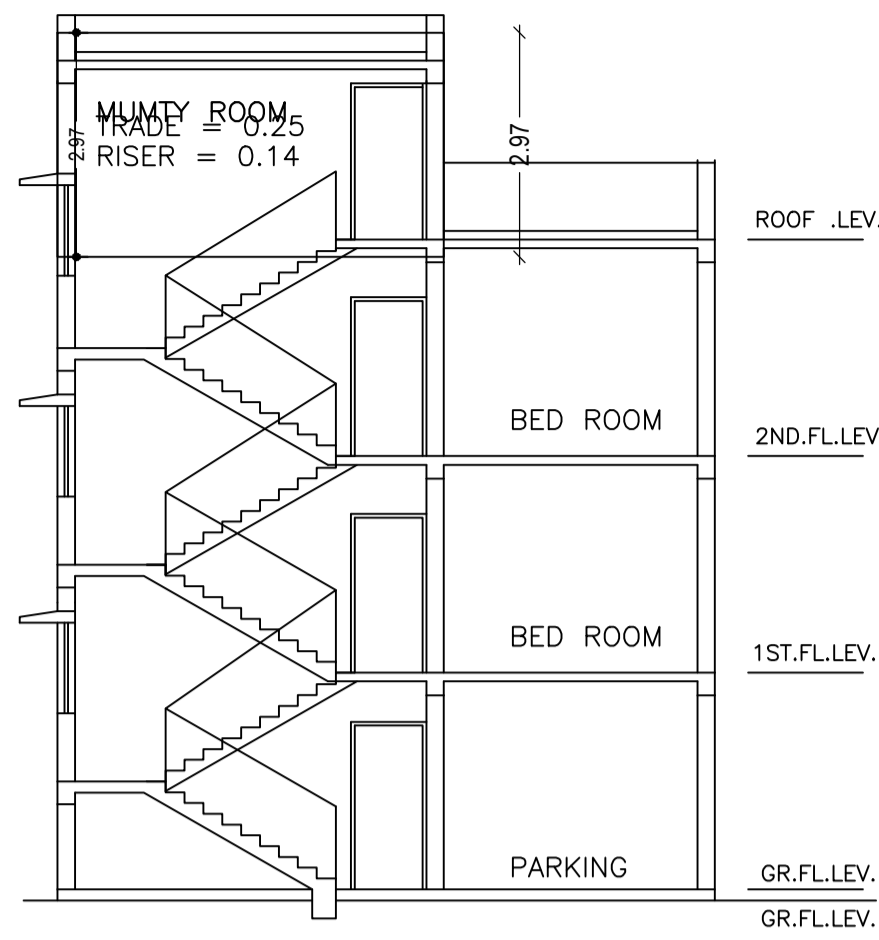

SCALE : 1:100

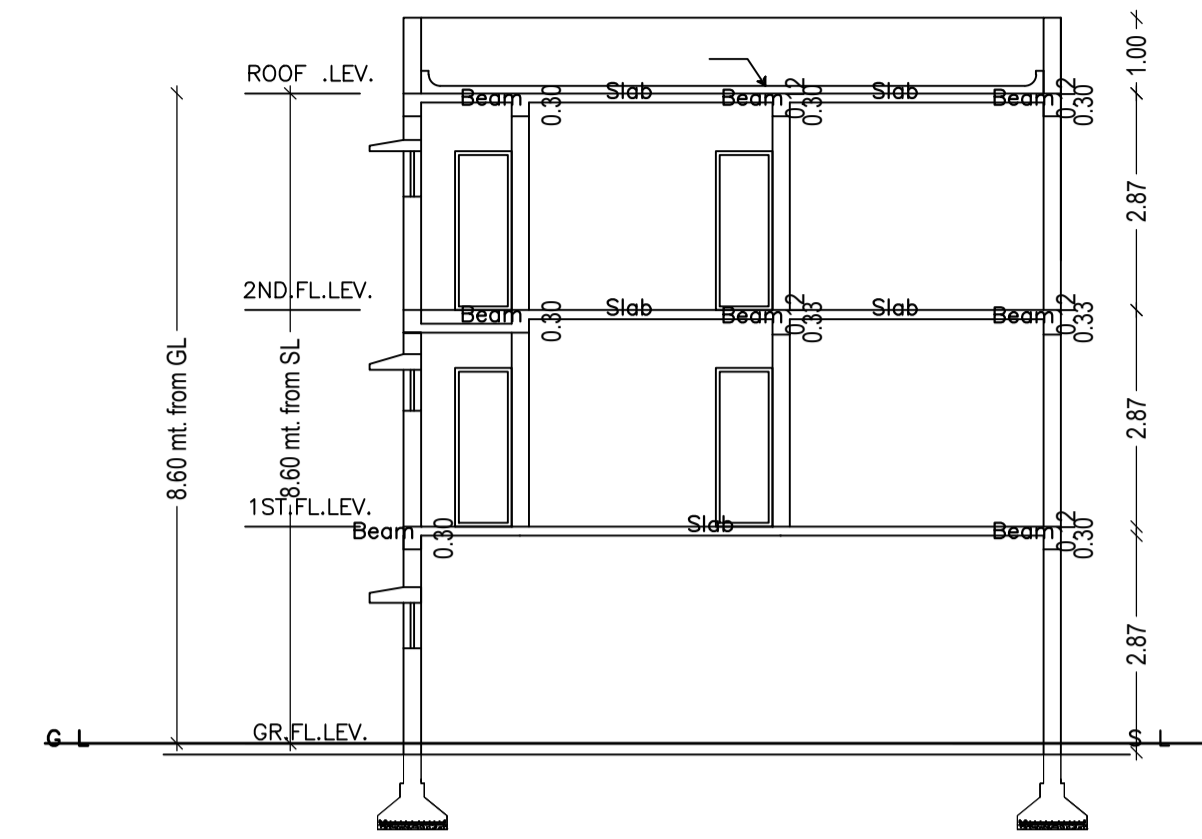

SECTION -Y-Y' (SCALE : 1:100)



FRONT ELEVATION (SCALE : 1:100)

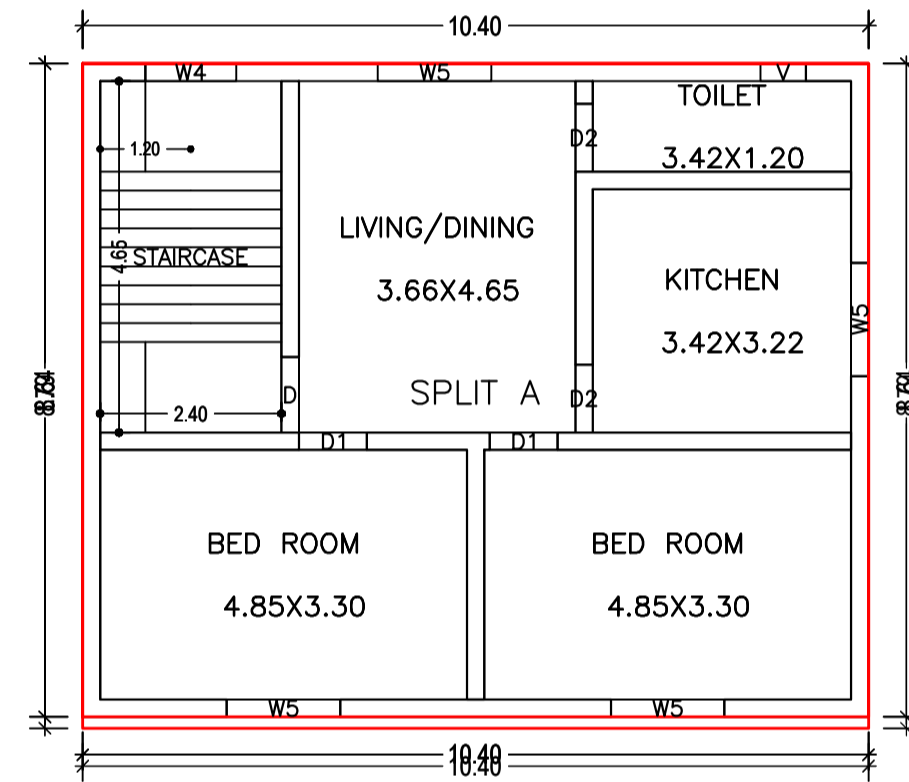

FIRST FLOOR PLAN (Proposed) (SCALE 1:100)

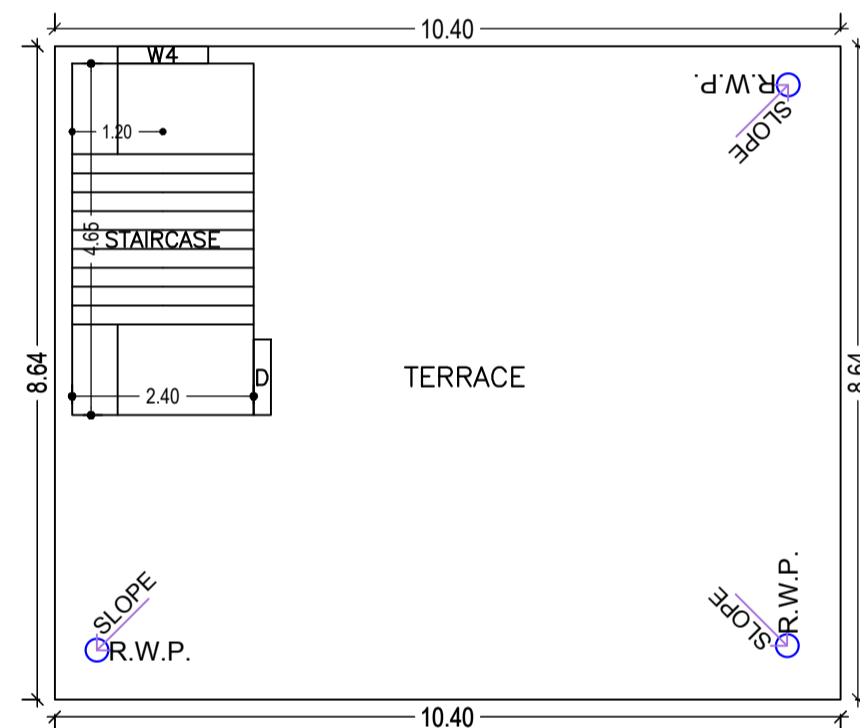

TERRACE FLOOR PLAN (SCALE 1:100)

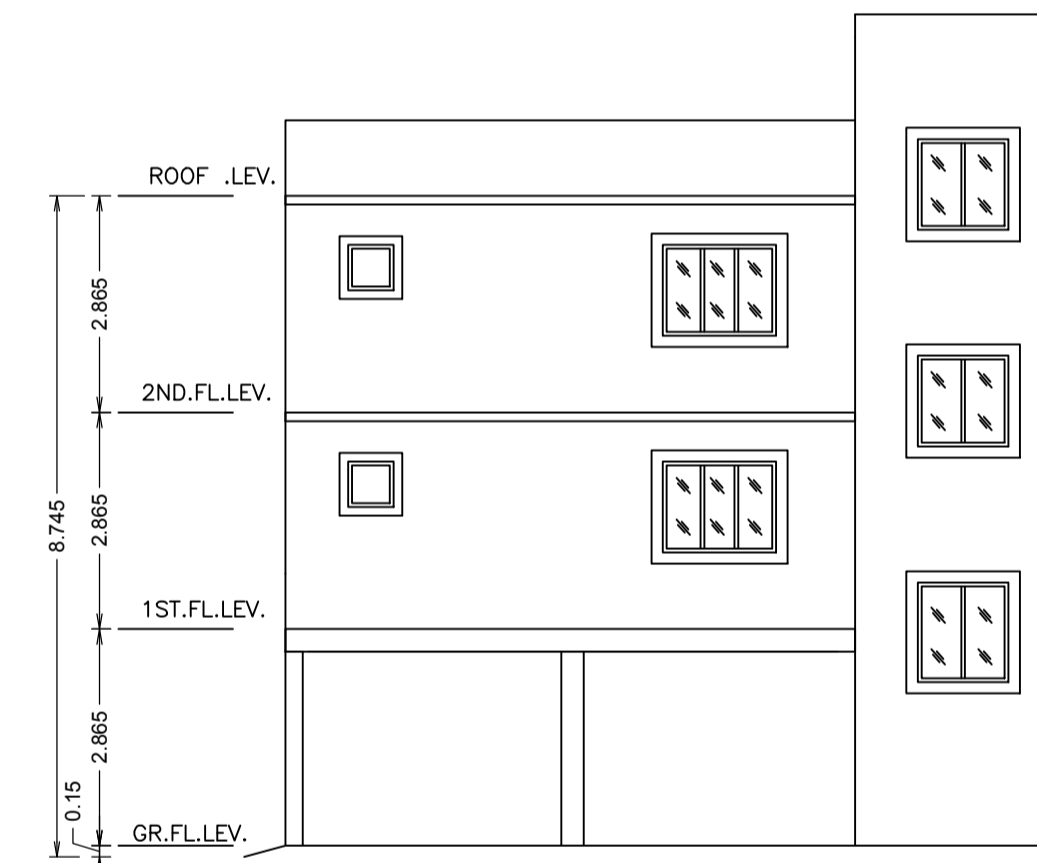

REAR ELEVATION (SCALE : 1:100)

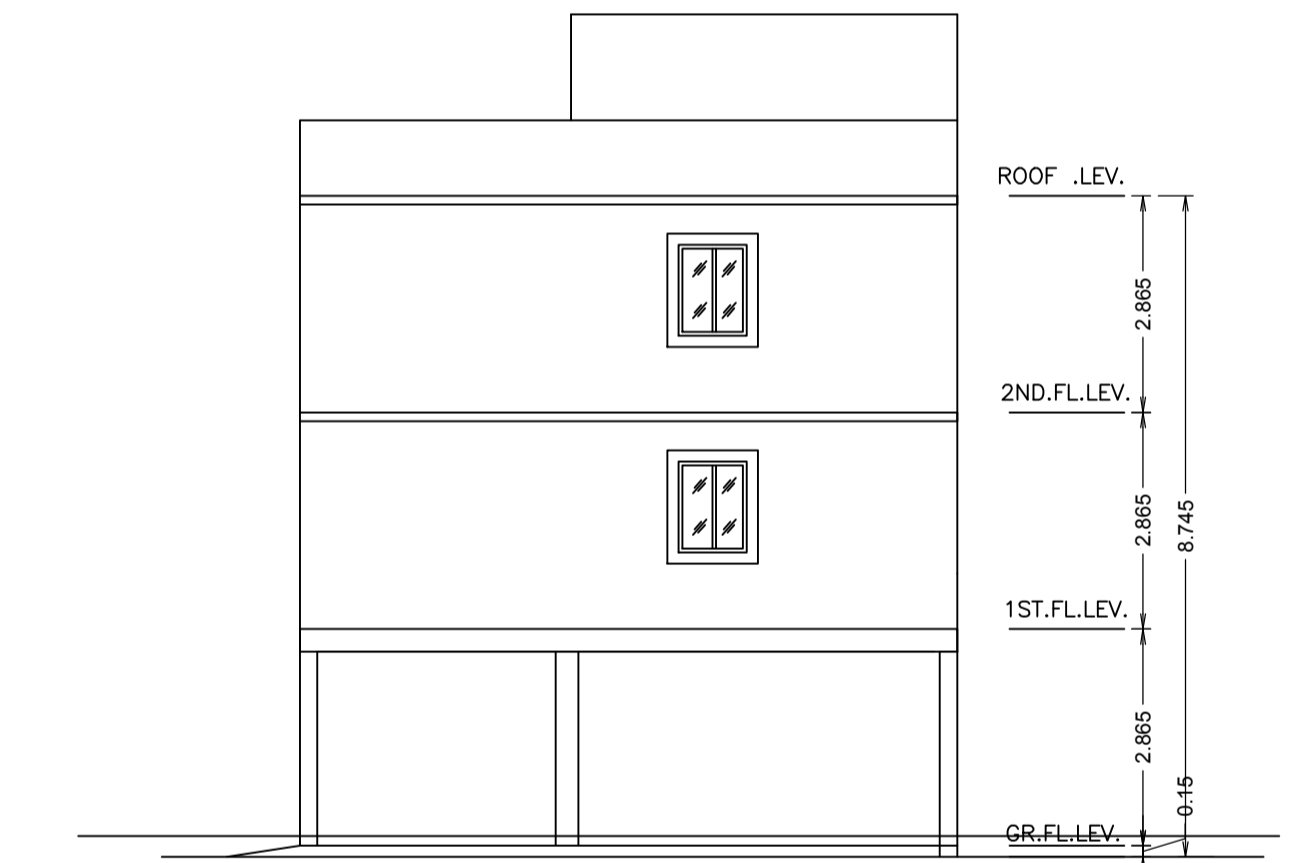

SIDE ELEVATION (SCALE : 1:100)

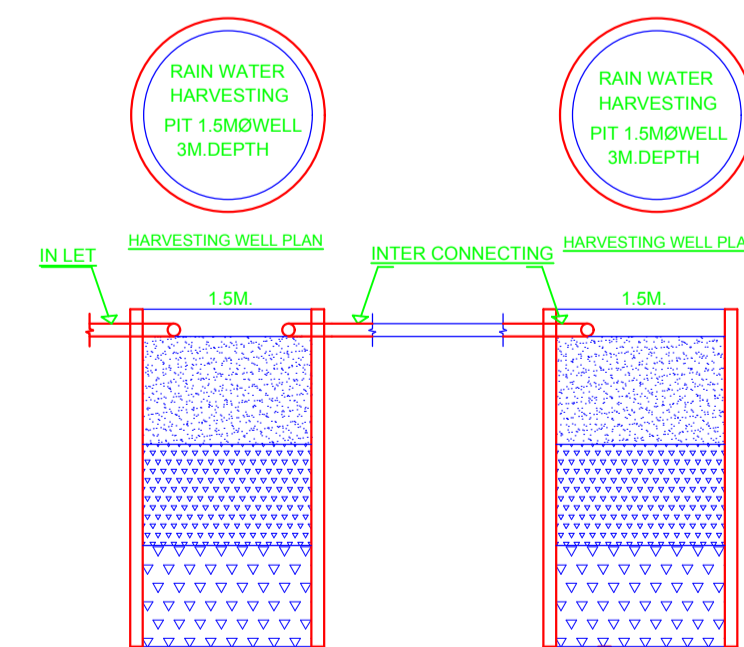

HARVESTING WELL SECTION

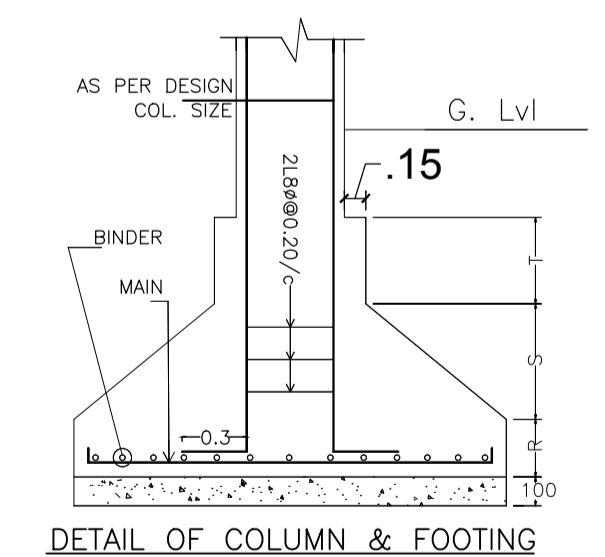

DETAIL OF COLUMN & FOOTING

Building :A (ANANT LAL)

Floor Name	Total Built Up Area (Sq.mt.)	Deductions (Area in Sq.mt.)		Proposed FAR Area (Sq.mt.)	Add Area In FAR (Sq.mt.)	Total FAR Area (Sq.mt.)	Total Consumed Additional FAR Area (Sq.mt.)	Trmt (No.)
		Parking	Resi.					
Ground Floor	89.81	78.65	0.00	11.16	11.16	11.16	0.00	00
First Floor	91.37	0.00	91.37	0.00	91.37	91.37	0.00	01
Second Floor	89.81	0.00	89.81	0.00	89.81	89.81	0.00	00
Terrace Floor	0.00	0.00	0.00	0.00	0.00	0.00	0.00	00
Total :	270.99	78.65	181.18	11.16	192.34	192.34	0.00	01
Total Number of Same Buildings	1							
Total :	270.99	78.65	181.18	11.16	192.34	192.34	0.00	01

SCHEDULE OF DOOR:

BUILDING NAME	NAME	LENGTH	HEIGHT	NOS
A (ANANT LAL)	D1	0.90	2.10	04
A (ANANT LAL)	D2	0.90	2.10	04
A (ANANT LAL)	D	1.00	2.10	02

SCHEDULE OF WINDOW/VENTILATION:

BUILDING NAME	NAME	LENGTH	HEIGHT	NOS
A (ANANT LAL)	V	0.60	0.60	02
A (ANANT LAL)	W4	1.20	1.20	04
A (ANANT LAL)	W5	1.50	1.20	08

UnitBUA Table for Building :A (ANANT LAL)

FLOOR	Name	UnitBUA Type	UnitBUA Area	Carpet Area	No. of Rooms	No. of Tenement
FIRST FLOOR PLAN	SPLIT A	FLAT	243.80	229.07	5	1
SECOND FLOOR PLAN	SPLIT A	FLAT	0.00	0.00	5	0
Total:	-	-	243.80	229.07	15	1

LTP NAME AND SIGNATURE	STRUCTURAL ENG'S NAME AND SIGNATURE	BUILDER NAME AND SIGNATURE	DIGITAL SIGNATURE
L K Suman JNAC/ENG/0006/2016			

Proposal Basic Information	
Proposal File No.	JNAC/BP/0077/W2/2020
Owner Name	Sri. Anant Lal POA Jaspal Singh
Khata No	Nil
Plot No	Ho. No-47, Gurudwara Bustee
Village Name	Bisthupur
Use	Residential
SubUse	Bungalow/ Dwelling / Non Apartment

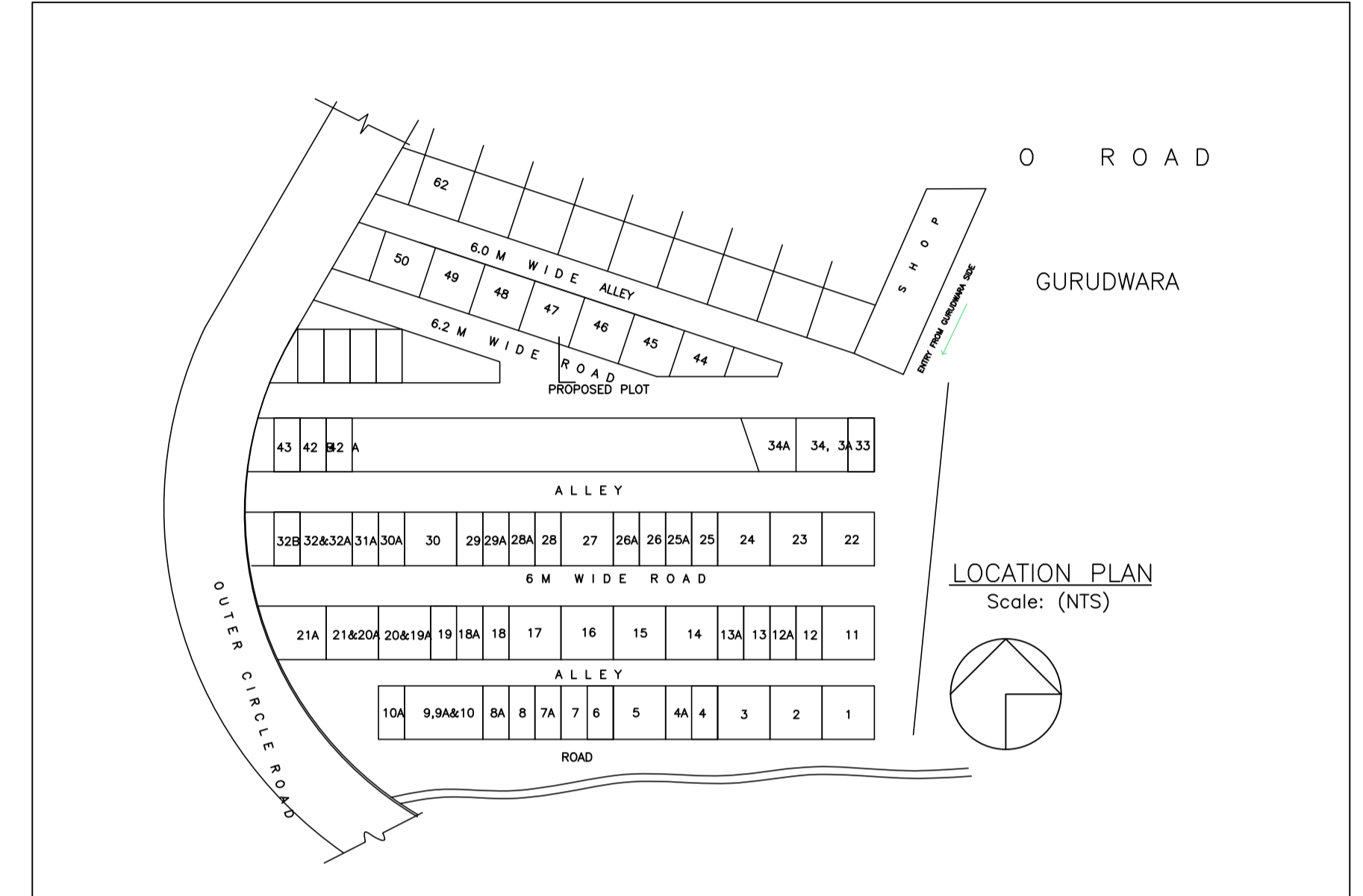

LTP NAME AND SIGNATURE	STRUCTURAL ENG'S NAME AND SIGNATURE	BUILDER NAME AND SIGNATURE	DIGITAL SIGNATURE
L K Suman JNAC/ENG/0006/2016			