

DETAIL OF PLOT  
Scale: (1:100)  
(Scale - 1:200)

FAR & Tenement Details (Table 4c-1)

Building	No. of Same Bldg	Total Built Up Area (Sq.mt.)	Deductions (Area in Sq.mt.)		Proposed FAR Area (Sq.mt.)		Add Area In FAR (Sq.mt.)	Total FAR Area (Sq.mt.)	Total Consumed Additional FAR Area (Sq.mt.)	Trmnt (No.)
			Accessory Use	Parking	Resi.	Stair				
A (MEGHA ARORA)	1	380.52	15.37	94.02	253.68	17.45	271.13	271.13	02	
Grand Total	1	380.52	15.37	94.02	253.68	17.45	271.13	271.13	02	

Proposal Basic Information

Proposal File No.	JNAC/ENG/0106/W1/2020
Owner Name	Mrs. Megha Arora
Khata No	10
Plot No	MIG-44/337
Village Name	SONAR
Use	Residential
SubUse	Bungalow/ Dwelling / Non Apartment

Required Parking (Table 7a)

Building Name	Type	SubUse	Area (Sq.mt.)	Units		Car		Visitors Car		
				Reqd.	Prop.	Reqd./Unit	Reqd.	Prop.	Reqd./Unit	Reqd.
A (MEGHA ARORA)	Residential	Bungalow/ Dwelling / Non Apartment	>0	1	2.00	1.00	2	-	-	-
			>0	1	2.00	-	-	1	1	-
Total :			-	-	-	-	2	2	-	1

Parking Check (Table 7b)

Vehicle Type	Reqd.		Prop.	
	No.	Area	No.	Area
Car	-	-	2	25.00
Total Car	2	25.00	2	25.00
Visitor's Car Parking	-	-	1	12.50
Total Visitor Parking	1	12.50	1	12.50
Other Parking	-	-	-	56.52
Total		37.50		94.02

AREA STATEMENT JAMSHEDPUR NAC	VERSION NO. : 1.0.56 VERSION DATE: 16/10/2020
PROJECT DETAIL:	
Region: JHARKHAND URBAN LOCAL BODIES	Plot Use: Residential
District: EAST SINGBHUM	Plot SubUse: Bungalow/ Dwelling / Non Apartment
Authority: JAMSHEDPUR NAC	PlotNearby/ReligiousStructure: NA
Inward_No: JNAC/EP/0106/W1/2020	PlotSubPlot No: MIG-44/337
Application Type: General Proposal	North: Road Width - 6.0
Project Type: Building Permission	South: Survey No. - OTHER PLOT
Nature of Development: New	East: Survey No. - OTHER PLOT
Location of Development Area: Old Area	West: Survey No. - OTHER PLOT
AREA DETAILS:	SQ.MT.
AREA OF PLOT (Minimum)	(A) 222.50
NET AREA OF PLOT(Gross Plot Area - Deduction from Gross Plot area)	(A-Deductions) 222.50
Deduction for Balance Plot Area(from Gross Plot Area)	
Common Plot	28.51
Total	28.51
BALANCE AREA OF PLOT(Net Plot Area - Recreational/Amenity space)	(A-Deductions) 193.99
PLOT AREA FOR COVERAGE(Net Plot Area)	(A-Deductions) 222.50
Plot Area for FAR (Net Plot Area + RoadWidening Area)	(A-Deductions) 222.50
COVERAGE CHECK	
Permissible Coverage area ( 70.00 % )	155.75
Proposed Coverage Area ( 57.01 % )	126.84
Total Prop. Coverage Area ( 57.01 % )	126.84
Balance coverage area ( 12.99 % )	28.91
FAR CHECK	
Perm. FAR Area ( 2.50 )	556.25
Total Perm. FAR area	556.25
Residential FAR	253.67
Proposed FAR Area	271.12
Total Proposed FAR Area	271.12
Consumed FAR (Factor)	1.22
Balance FAR Area	285.13
BUILT UP AREA CHECK	
Total Proposed BuiltUp Area	380.52
ARCHITECT (Regd)	L K Suman
ENGINEER (Regd)	
SUPERVISOR (Regd)	
OWNER (Regd)	Mrs. Megha Arora
DEVELOPMENT AUTHORITY	LOCAL BODY

COLOR INDEX	
PLOT BOUNDARY	Black
ABUTTING ROAD	Green
PROPOSED CONSTRUCTION	Red
COMMON PLOT	Yellow
ROAD WIDENING AREA	Orange
EXISTING (To be retained)	Blue
EXISTING (To be demolished)	Light Blue

Buildingwise Floor FAR Details

Floor Name	Building Name A (MEGHA ARORA)		Total	
	Proposed Built Up Area (Sq.mt.)	Proposed FAR Area (Sq.mt.)	Total Proposed Built Up Area (Sq.mt.)	Total FAR Area (Sq.mt.)
Parking Floor	126.84	17.45	126.84	17.45
First Floor	126.84	126.84	126.84	126.84
Second Floor	126.84	126.84	126.84	126.84
Terrace Floor	0.00	0.00	0.00	0.00
Total :	380.52	271.13	380.52	271.13

Building USE/SUBUSE Details

Building Name	Building Use	Building SubUse	Building Structure
A (MEGHA ARORA)	Residential	Bungalow/ Dwelling / Non Apartment	Non-Highrise

LTP NAME AND SIGNATURE	STRUCTURAL ENG'S NAME AND SIGNATURE	BUILDER NAME AND SIGNATURE	DIGITAL SIGNATURE
L K Suman JNAC/ENG/0006/2016			

Proposal Basic Information	
Proposal File No.	JNAC/ENG/0006/W1/2020
Owner Name	Mrs. Megha Arora
Khata No	10
Plot No	MIG-44/337
Village Name	SONAR
Use	Residential
SubUse	Bungalow/ Dwelling / Non Apartment

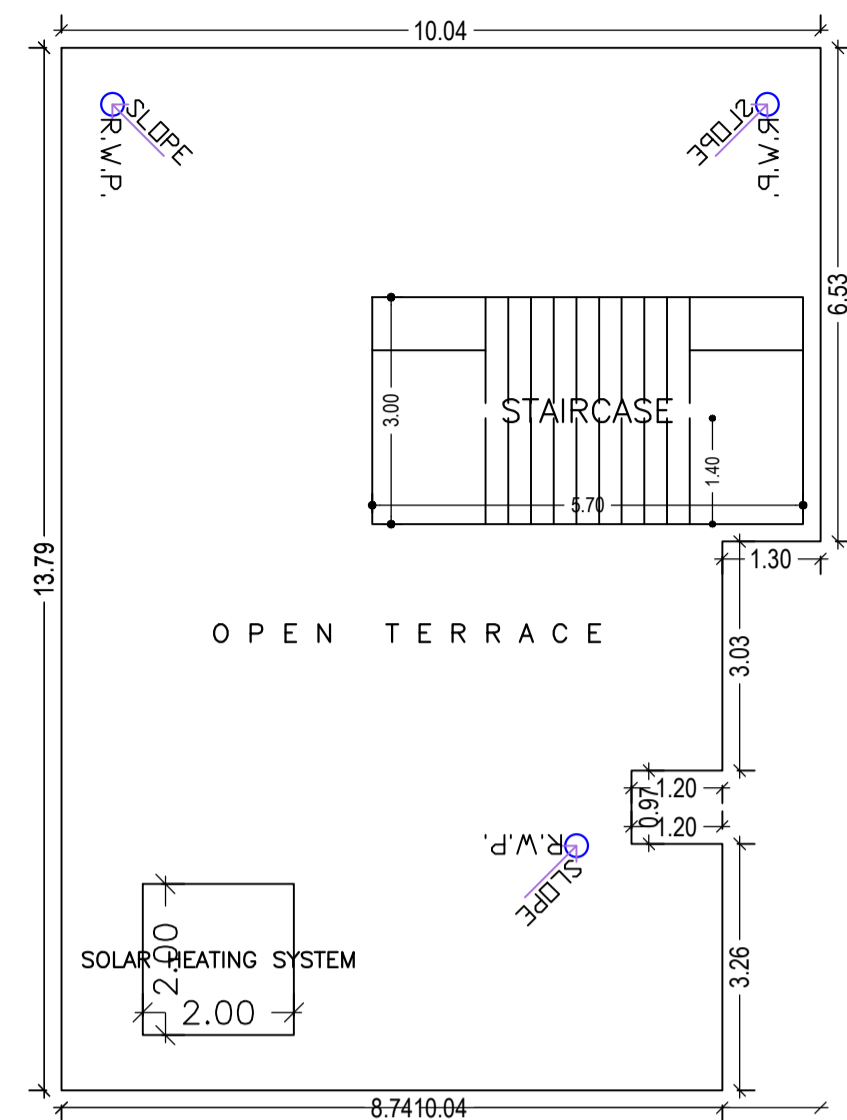
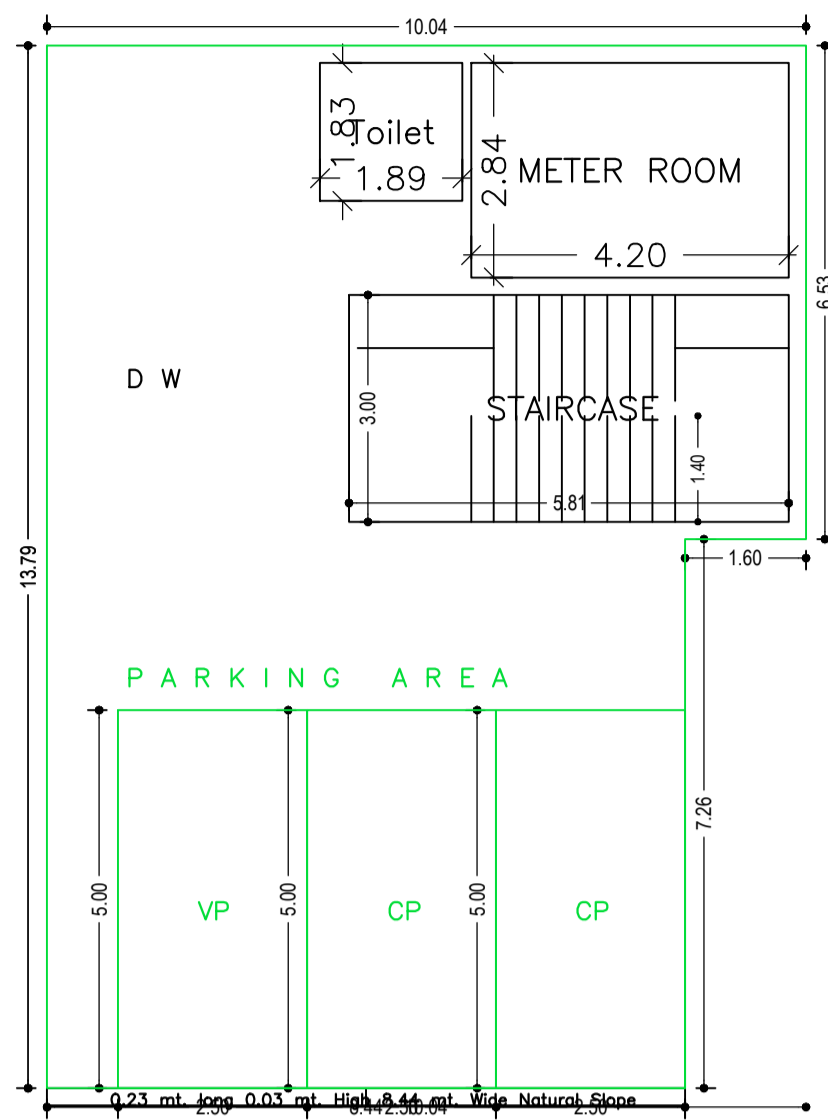

TERRACE FLOOR PLAN (SCALE 1:100)

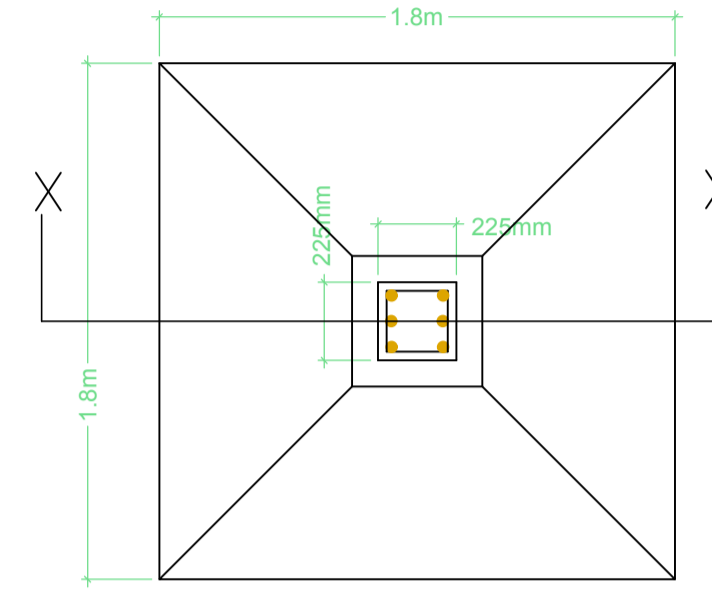

DETAIL OF FOOTING (Not to Scale)

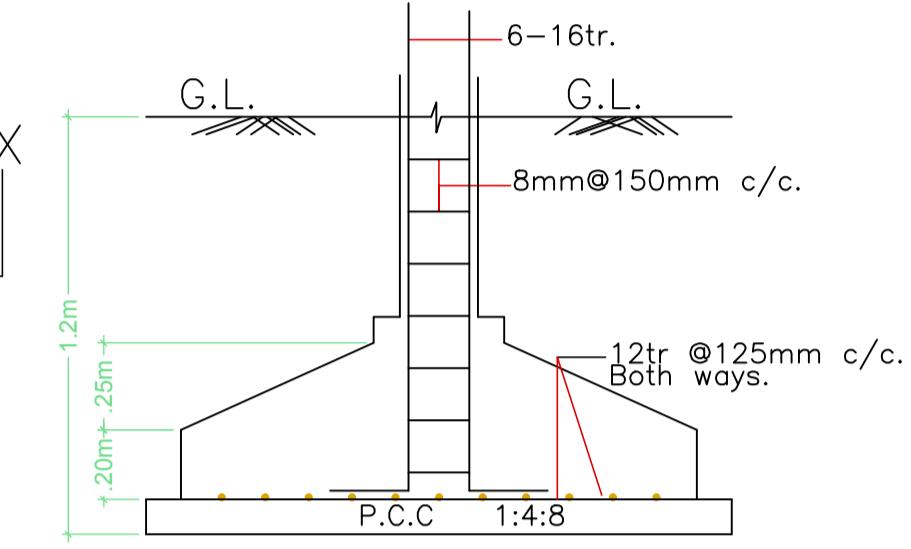

SECTION ON X-X



FRONT ELEVATION Scale: (1:100)

PARKING FLOOR PLAN (SCALE 1:100)

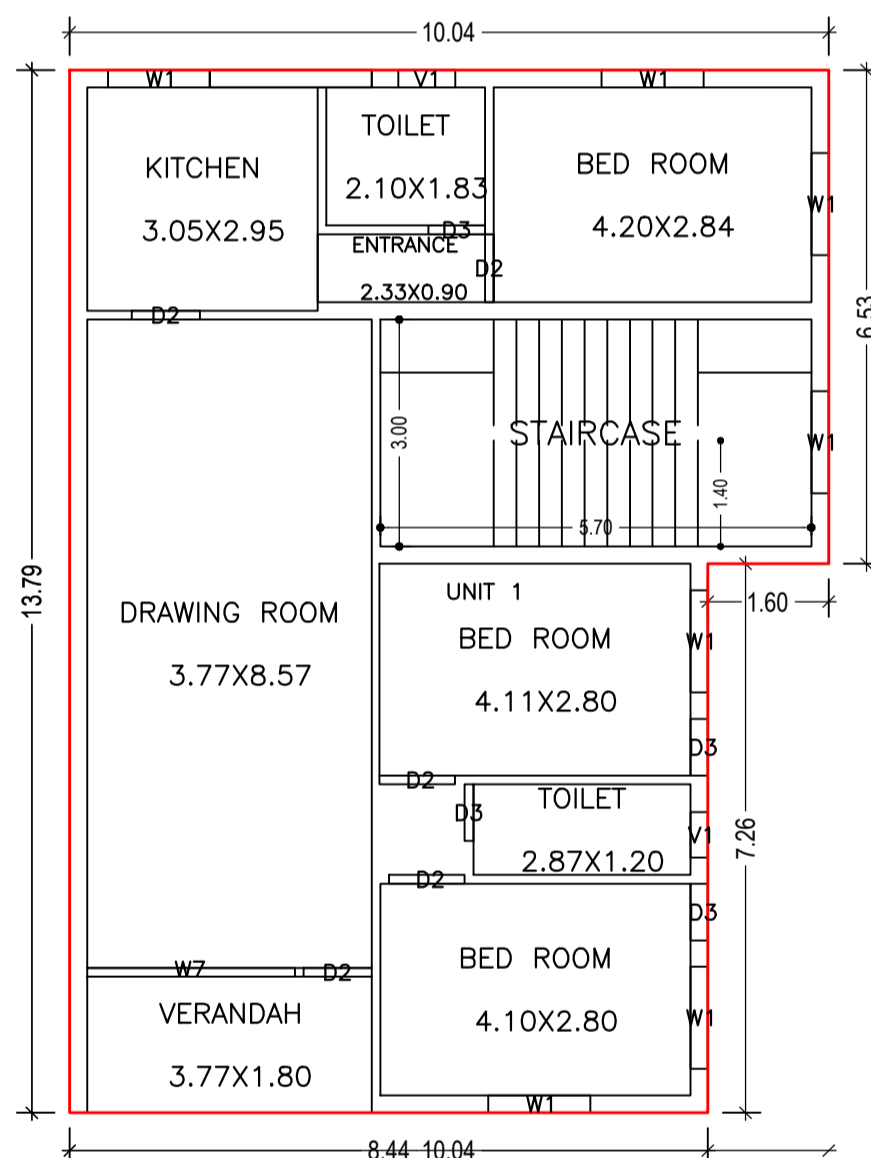

TYPICAL - 1& 2 FLOOR PLAN (Proposed) (SCALE 1:100)

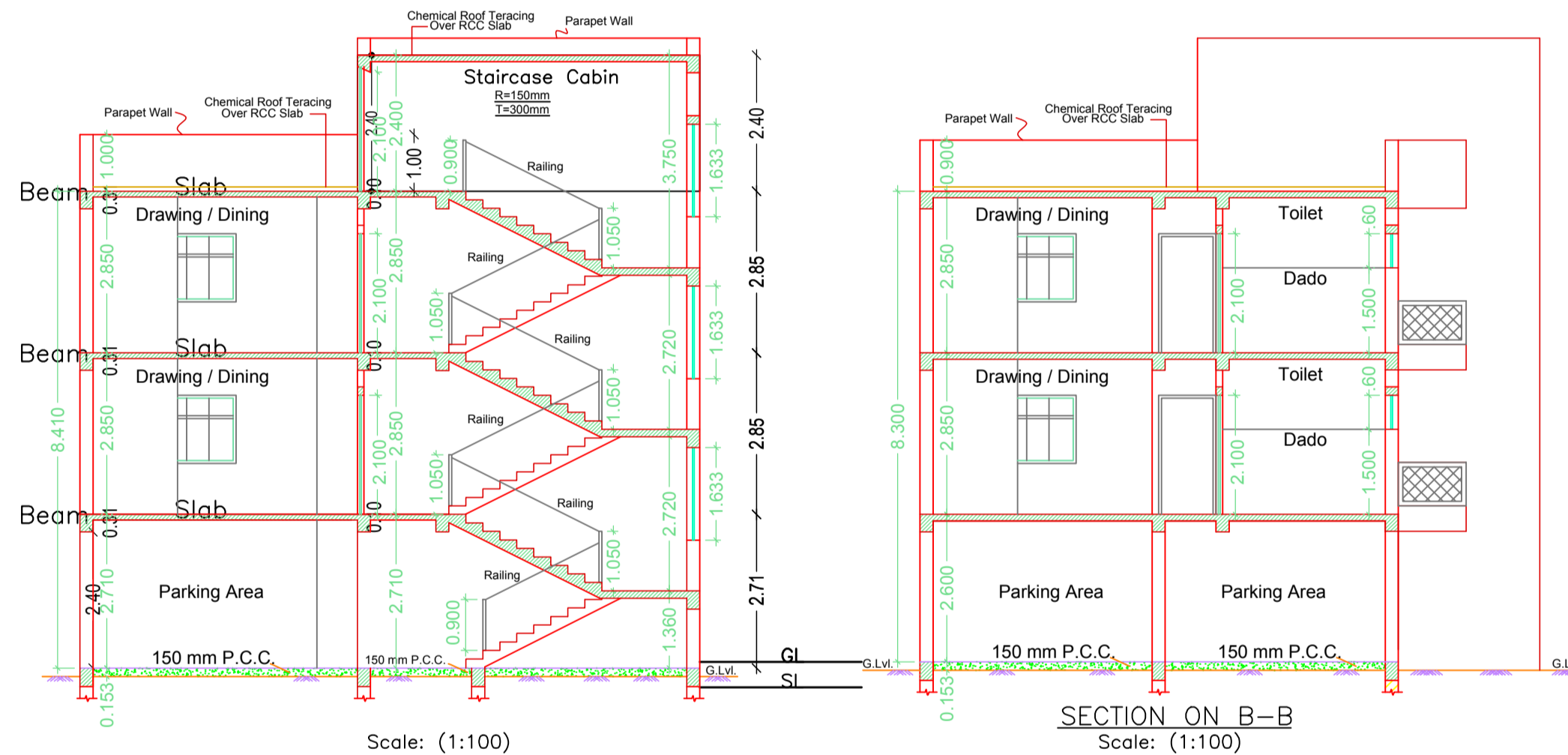

SECTION ON B-B Scale: (1:100)

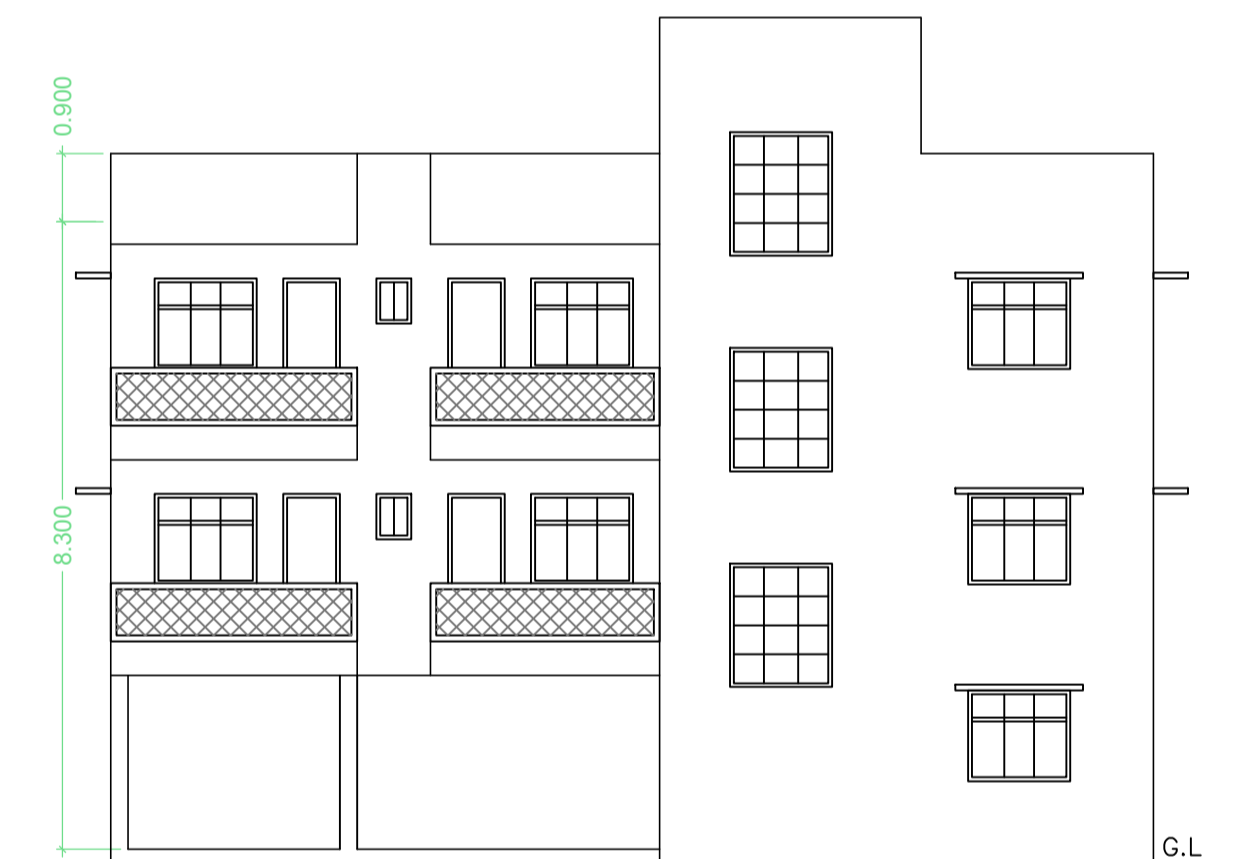

SIDE ELEVATION Scale: (1:100)

Building :A (MEGHA ARORA)

Floor Name	Total Built Up Area (Sq.mt.)	Deductions (Area in Sq.mt.)		Proposed FAR Area (Sq.mt.)	Add Area In FAR (Sq.mt.)	Total Consumed FAR Area (Sq.mt.)	Total Additional FAR Area (Sq.mt.)	Trmt (No.)
		Accessory Use	Parking					
Parking Floor	126.84	15.37	94.02	0.00	17.45	17.45	17.45	00
First Floor	126.84	0.00	0.00	126.84	0.00	126.84	126.84	01
Second Floor	126.84	0.00	0.00	126.84	0.00	126.84	126.84	01
Terrace Floor	0.00	0.00	0.00	0.00	0.00	0.00	0.00	00
Total :	380.52	15.37	94.02	253.68	17.45	271.13	271.13	02
Total Number of Same Buildings	1							
Total :	380.52	15.37	94.02	253.68	17.45	271.13	271.13	02

SCHEDULE OF DOOR:

BUILDING NAME	NAME	LENGTH	HEIGHT	NOS
A (MEGHA ARORA)	D3	0.75	2.10	08
A (MEGHA ARORA)	D2	0.90	2.10	06
A (MEGHA ARORA)	D2	1.00	2.10	04

SCHEDULE OF WINDOW/VENTILATION:

BUILDING NAME	NAME	LENGTH	HEIGHT	NOS
A (MEGHA ARORA)	V1	0.60	0.60	02
A (MEGHA ARORA)	V1	0.75	0.60	02
A (MEGHA ARORA)	W1	1.35	1.20	14
A (MEGHA ARORA)	W7	2.75	1.20	02

UnitBUA Table for Building :A (MEGHA ARORA)

FLOOR	Name	UnitBUA Type	UnitBUA Area	Carpet Area	No. of Rooms	No. of Tenement
TYPICAL - 1& 2 FLOOR PLAN	UNIT 1	FLAT	126.84	126.34	9	2
Total:	-	-	253.67	252.69	18	2

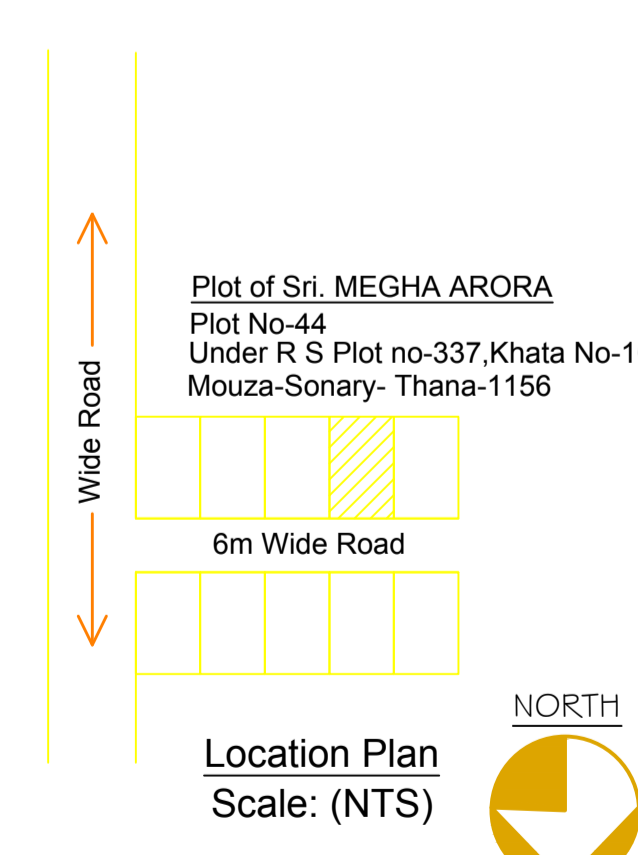

Plot of Sri. MEGHA ARORA  
Plot No-44  
Under R S Plot no-337, Khata No-10  
Mouza-Sonary- Thana-1156

Location Plan Scale: (NTS)

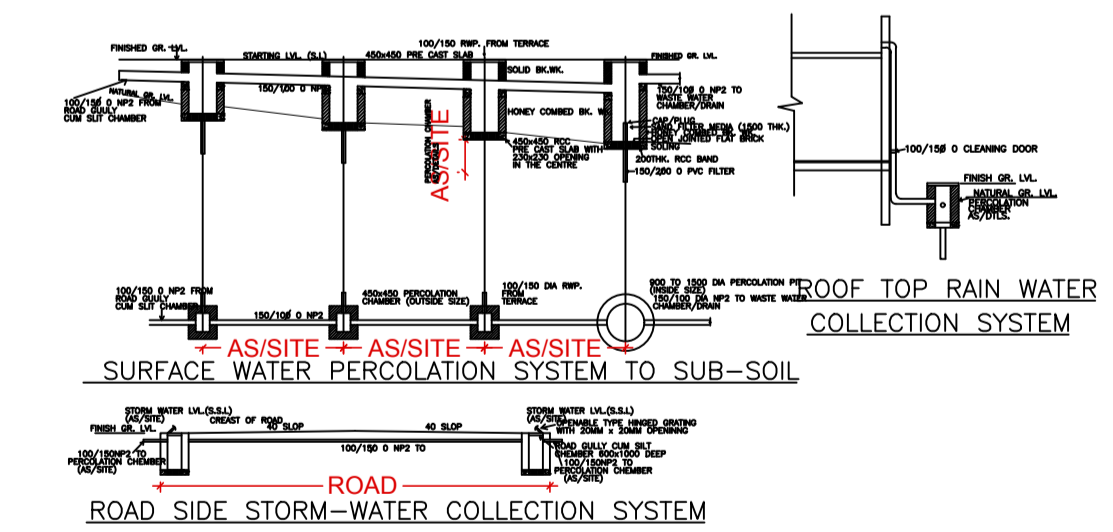

LTP NAME AND SIGNATURE	STRUCTURAL ENG'S NAME AND SIGNATURE	BUILDER NAME AND SIGNATURE	DIGITAL SIGNATURE
L K Suman JNAC/ENG/0006/2016			

Proposal Basic Information	
Proposal File No.	JNAC/ENG/0006/W1/2020
Owner Name	Mrs. Megha Arora
Khata No	10
Plot No	MIG-4/337
Village Name	SONAR
Use	Residential
SubUse	Bungalow/ Dwelling / Non Apartment

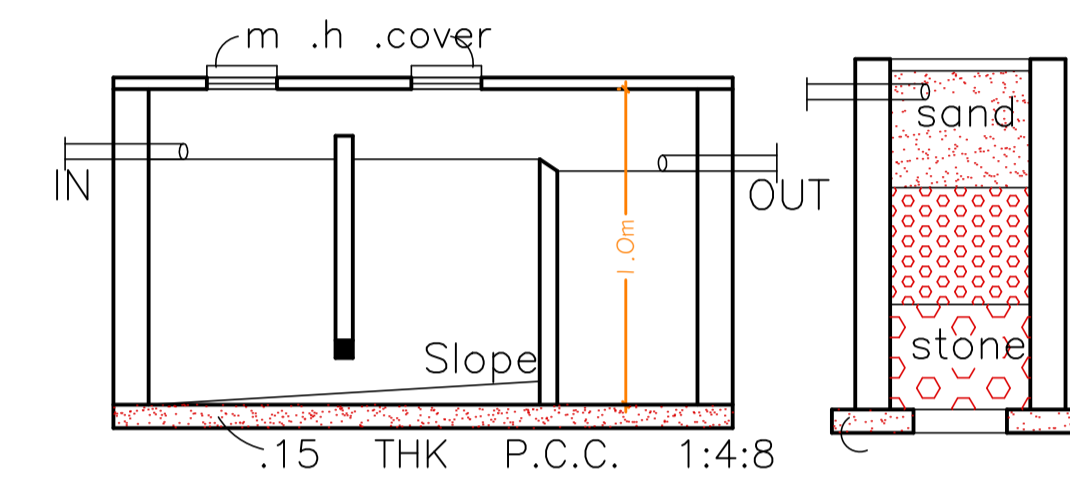
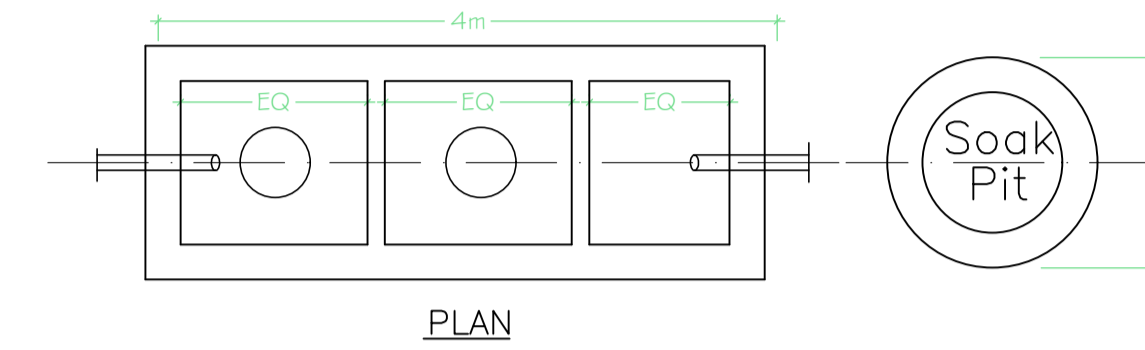

LTP NAME AND SIGNATURE	STRUCTURAL ENG'S NAME AND SIGNATURE	BUILDER NAME AND SIGNATURE	DIGITAL SIGNATURE
L.K. Suman JNAC/ENG/0006/2016			