

FAR & Tenement Details (Table 4c-1)

Building	No. of Same Bldg	Total Built Up Area (Sq.mt.)	Deductions (Area in Sq.mt.)	Proposed FAR Area (Sq.mt.)	Add Area In FAR (Sq.mt.)	Total FAR Area (Sq.mt.)	Total Consumed Additional FAR Area (Sq.mt.)	Tnmt (No.)
A (SMT P ANURADHA)	1	191.73	55.41	127.82	8.50	136.32	136.32	01
Grand Total :	1	191.73	55.41	127.82	8.50	136.32	136.32	01

Proposal Basic Information

Proposal File No.	JNAC/BP/0127/W1/2021
Owner Name	SMT. P. ANURADHA
Khata No	622
Plot No	1343
Village Name	SONARI
Use	Residential
SubUse	Bungalow/ Dwelling / Non Apartment

AREA STATEMENT JAMSHEDPUR NAC

Region: JHARKHAND URBAN LOCAL BODIES	Plot Use: Residential
District: EAST SINGHBHUM	Plot SubUse: Bungalow/ Dwelling / Non Apartment
Authority: JAMSHEDPUR NAC	PlotNearby/ReligiousStructure: NA
Inward_No: JNAC/BP/0127/W1/2021	PlotSubPlot No: 1343
Application Type: General Proposal	North: -
Project Type: Building Permission	South: -
Nature of Development: New	East: Road Width - 9.0 MTR WIDE MAIN ROAD
Location of Development Area: Old Area	West: Road Width - 3.0 MTR WIDE ALLEY

AREA DETAILS:

AREA OF PLOT (Minimum)	(A)	SQ.MT.
NET AREA OF PLOT(Gross Plot Area - Deduction from Gross Plot area)	(A-Deductions)	111.41
Deduction for Balance Plot Area(from Gross Plot Area)		
Common Plot		18.45
Total		18.45
BALANCE AREA OF PLOT(Net Plot Area - Recreational/Amenity space)	(A-Deductions)	92.96
PLOT AREA FOR COVERAGE(Net Plot Area)	(A-Deductions)	111.41
Plot Area for FAR (Net Plot Area + RoadWidening Area)	(A-Deductions)	111.41

COVERAGE CHECK

Permissible Coverage area (70.00 %)	77.99
Proposed Coverage Area (57.36 %)	63.91
Total Prop. Coverage Area (57.36 %)	63.91
Balance coverage area (12.64 %)	14.08

FAR CHECK

Perm. FAR Area (2.50)	278.53
Total Perm. FAR area	278.53
Residential FAR	127.82
Proposed FAR Area	136.32
Total Proposed FAR Area	136.32
Consumed FAR (Factor)	1.22
Balance FAR Area	142.21

BUILT UP AREA CHECK

Total Proposed BuiltUp Area	191.73
-----------------------------	--------

ARCHITECT (Regd) Amarjeet Balmuchu
ENGINEER (Regd)
SUPERVISOR (Regd)
OWNER (Regd) SMT. P. ANURADHA

DEVELOPMENT AUTHORITY LOCAL BODY

SITE PLAN

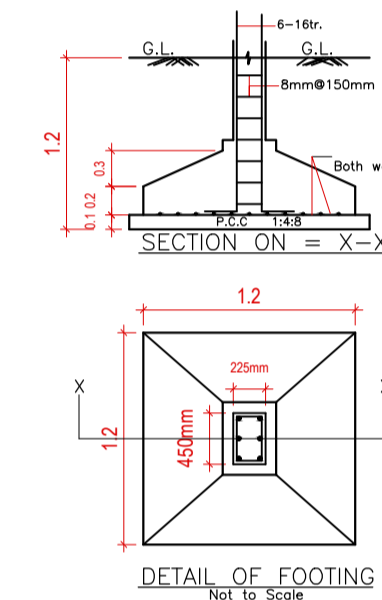
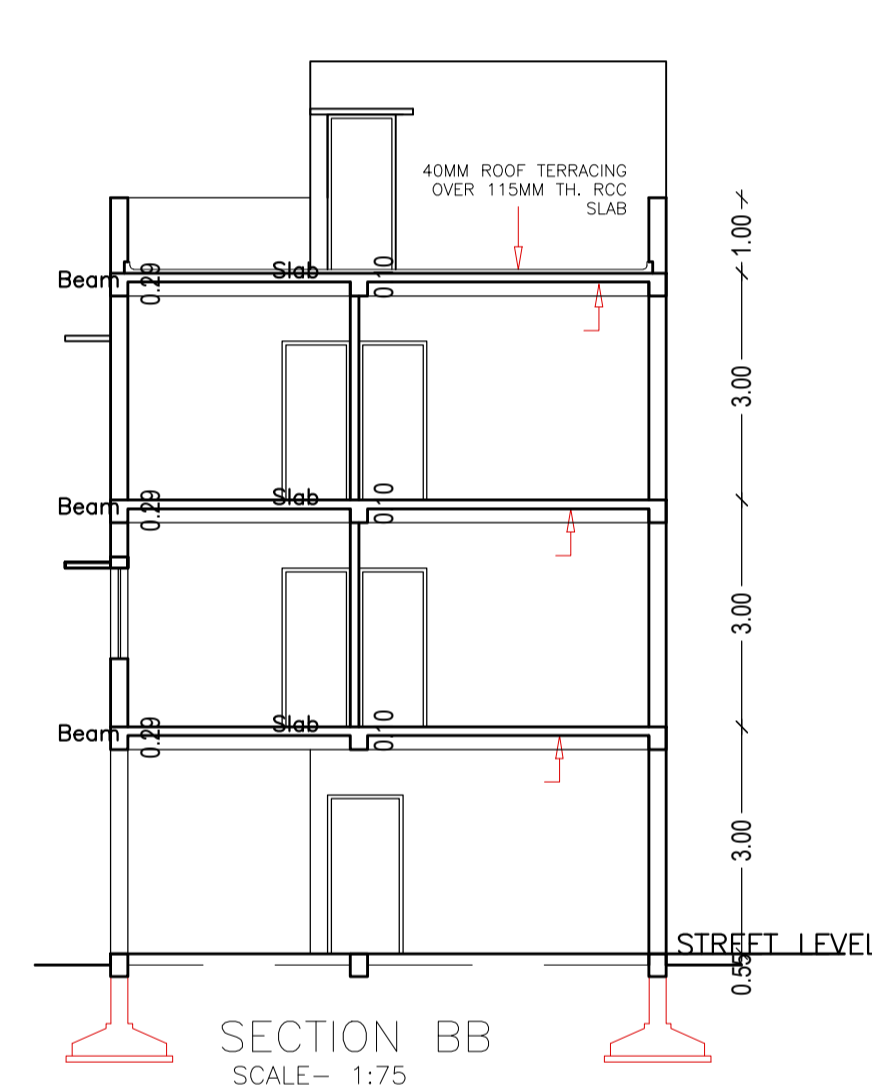
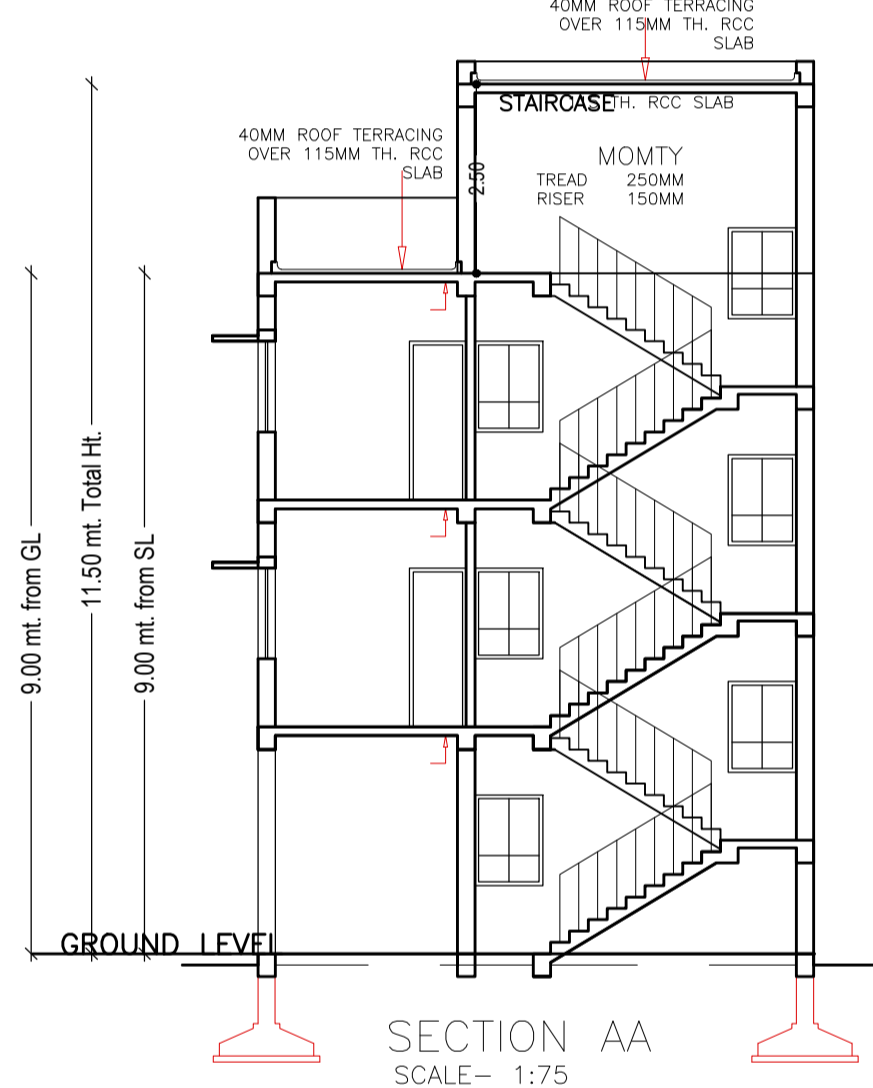
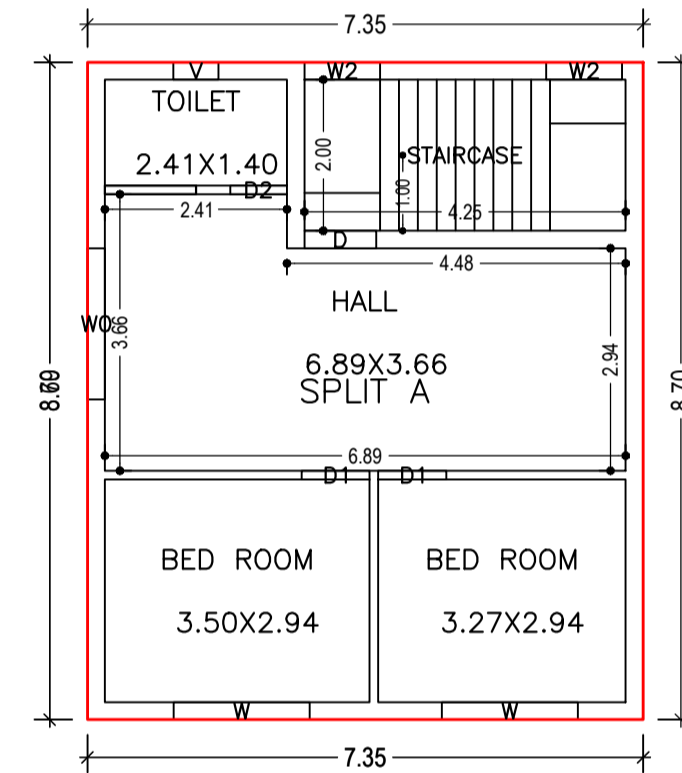
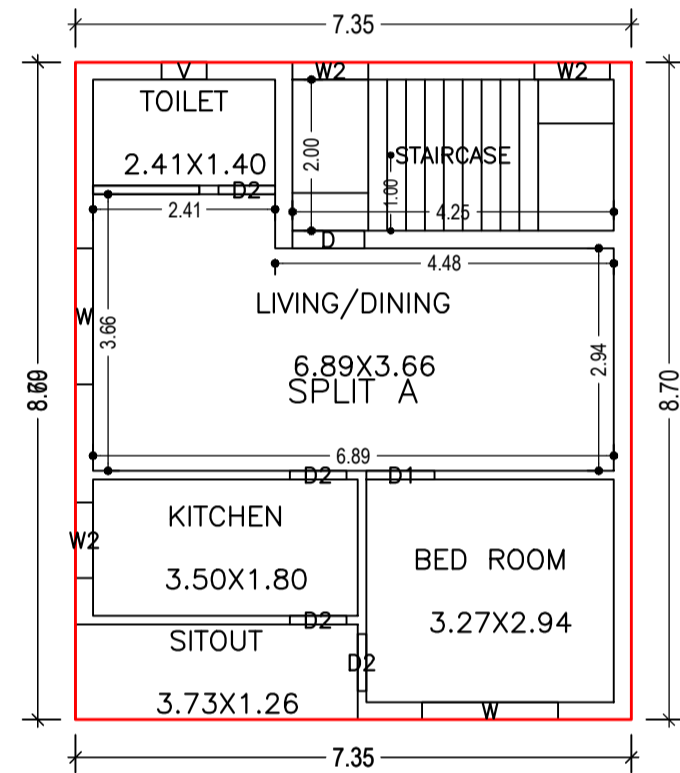
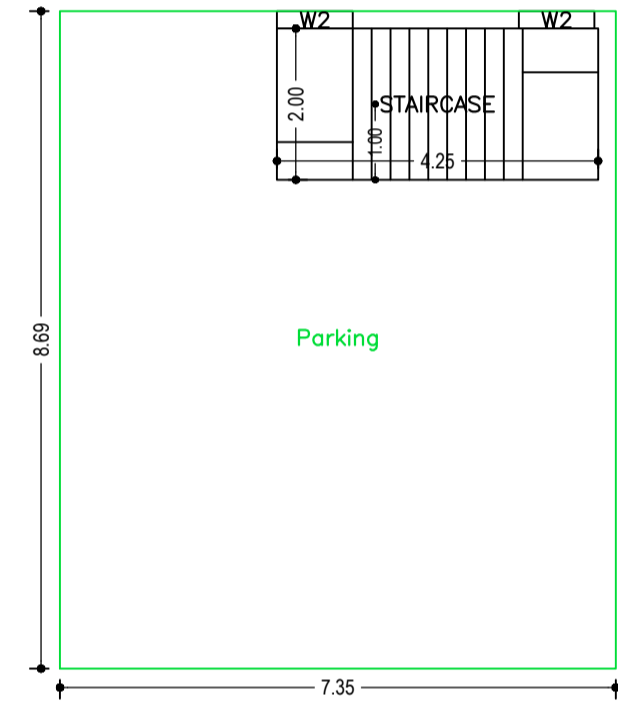

GROUND FLOOR PLAN (SCALE 1:100)

FIRST FLOOR PLAN (Proposed) (SCALE 1:100)

SECOND FLOOR PLAN (Proposed) (SCALE 1:100)

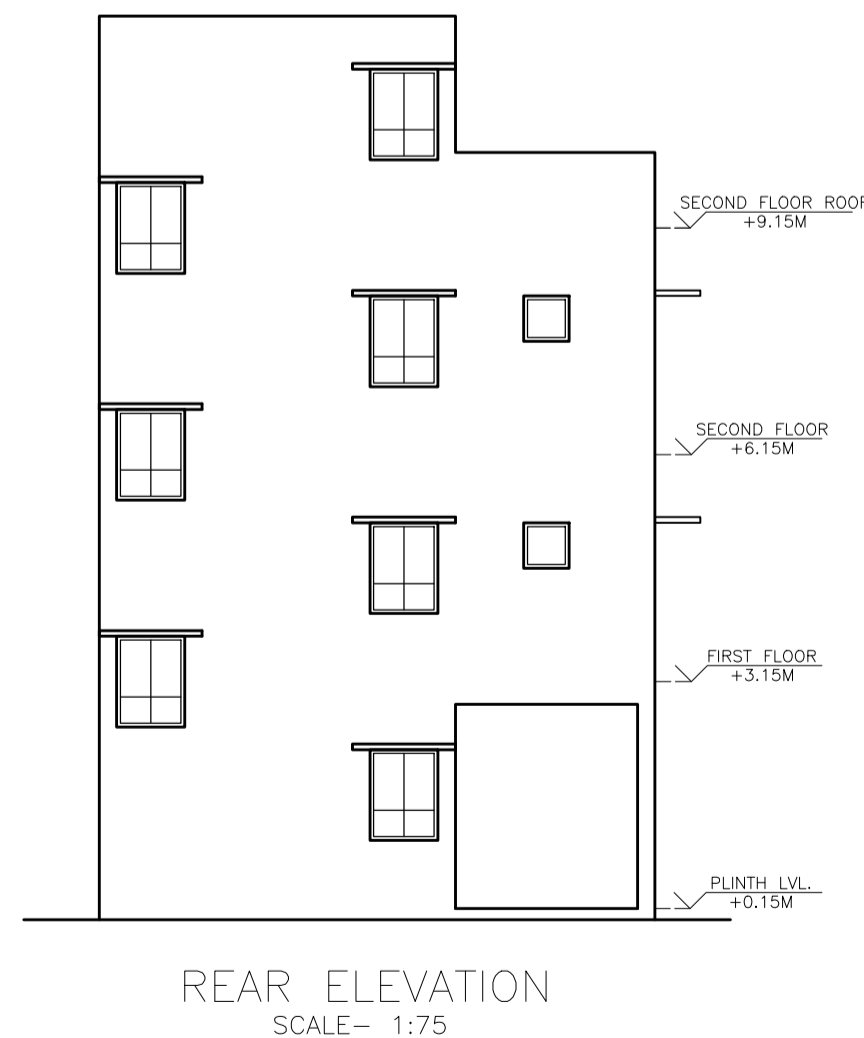
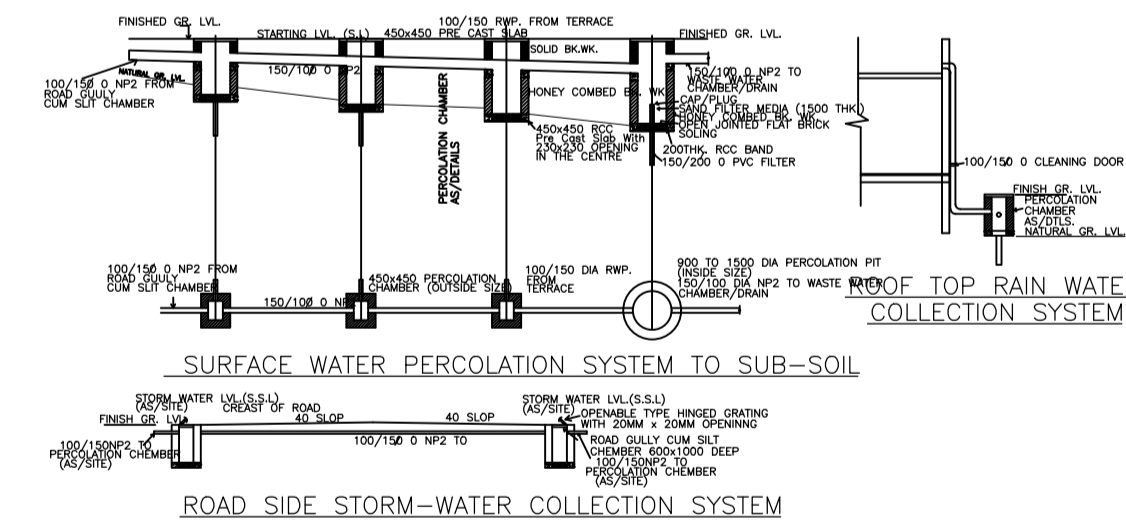

Building :A (SMT P ANURADHA)

Floor Name	Total Built Up Area (Sq.mt.)	Deductions (Area in Sq.mt.)	Proposed FAR Area (Sq.mt.)	Add Area In FAR (Sq.mt.)	Total FAR Area (Sq.mt.)	Total Consumed Additional FAR Area (Sq.mt.)	Tnmt (No.)
Ground Floor	63.91	55.41	0.00	8.50	8.50	8.50	00
First Floor	63.91	0.00	63.91	0.00	63.91	63.91	01
Second Floor	63.91	0.00	63.91	0.00	63.91	63.91	00
Terrace Floor	0.00	0.00	0.00	0.00	0.00	0.00	00
Total :	191.73	55.41	127.82	8.50	136.32	136.32	01

SCHEDULE OF DOOR:

BUILDING NAME	NAME	LENGTH	HEIGHT	NOS
A (SMT P ANURADHA)	D2	0.75	2.13	05
A (SMT P ANURADHA)	D1	0.90	2.13	03
A (SMT P ANURADHA)	D	0.95	2.13	02

SCHEDULE OF WINDOW/VENTILATION:

BUILDING NAME	NAME	LENGTH	HEIGHT	NOS
A (SMT P ANURADHA)	V	0.60	2.70	02
A (SMT P ANURADHA)	W2	1.00	2.70	07
A (SMT P ANURADHA)	W	1.80	2.70	04
A (SMT P ANURADHA)	W0	2.00	2.70	01

UnitBUA Table for Building :A (SMT P ANURADHA)

FLOOR	Name	UnitBUA Type	UnitBUA Area	Carpet Area	No. of Rooms	No. of Tenement
FIRST FLOOR PLAN	SPLIT A	FLAT	94.59	94.29	5	1
SECOND FLOOR PLAN	SPLIT A	FLAT	0.00	0.00	4	0
Total:	-	-	94.59	94.29	9	1

COLOR INDEX

PLOT BOUNDARY	Black
ABUTTING ROAD	Green
PROPOSED CONSTRUCTION	Red
COMMON PLOT	Yellow
ROAD WIDENING AREA	Blue
EXISTING (To be retained)	Light Blue
EXISTING (To be demolished)	Light Yellow

Buildingwise Floor FAR Details

Floor Name	Building Name A (SMT P ANURADHA)		Total	
	Proposed Built Up Area (Sq.mt.)	Proposed FAR Area (Sq.mt.)	Total Proposed Built Up Area (Sq.mt.)	Total FAR Area (Sq.mt.)
Ground Floor	63.91	8.50	63.91	8.50
First Floor	63.91	63.91	63.91	63.91
Second Floor	63.91	63.91	63.91	63.91
Terrace Floor	0.00	0.00	0.00	0.00
Total :	191.73	136.32	191.73	136.32

Building USE/SUBUSE Details

Building Name	Building Use	Building SubUse	Building Structure
A (SMT P ANURADHA)	Residential	Bungalow/ Dwelling / Non Apartment	Non-Highrise

LTP NAME AND SIGNATURE	STRUCTURAL ENG'S NAME AND SIGNATURE	BUILDER NAME AND SIGNATURE	DIGITAL SIGNATURE
Amarjeet Balmuchu JNAC/ARC/0008/2018			