

Proposal Basic Information	
Proposal File No.	JNAC/BP/0134/W4/2021
Owner Name	SAHOOD AHMAD KHAN
Khata No	2
Plot No	187
Village Name	Bisthupur
Use	Residential
SubUse	Bungalow/ Dwelling / Non Apartment

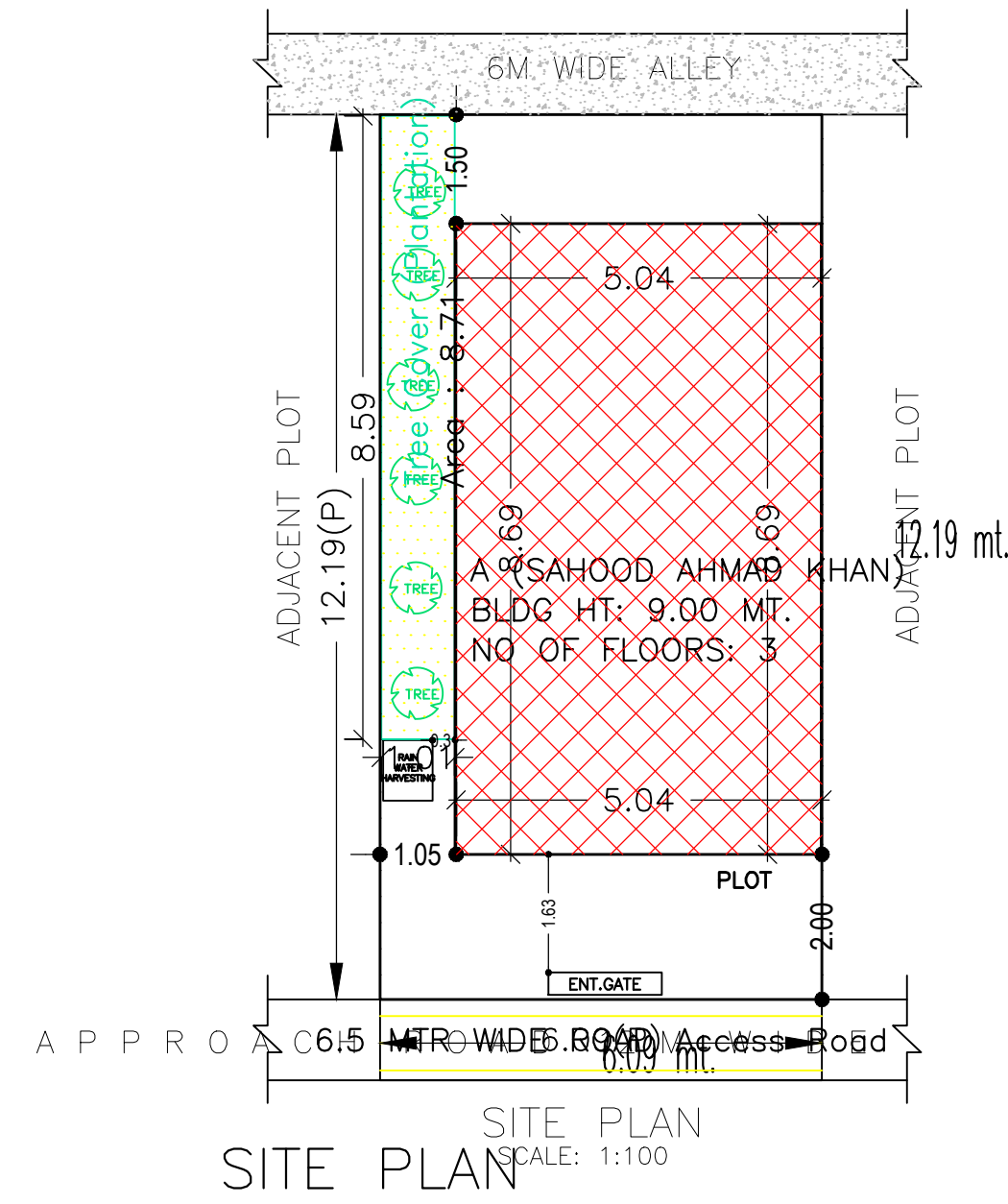

AREA STATEMENT	VERSION NO.: 1.0.62		
JAMSHEDPUR NAC	VERSION DATE: 16/10/2020		
PROJECT DETAIL:			
Region: JHARKHAND URBAN LOCAL BODIES	Plot Use: Residential		
District: EAST SINGHBHUM	Plot SubUse: Bungalow/ Dwelling / Non Apartment		
Authority: JAMSHEDPUR NAC	Plot/Nearby/Religious Structure: NA		
Inward No: JNAC/BP/0134/W4/2021	Plot/SubPlot No: 187		
Application Type: General Proposal	North: Road Width - 6.10 MTR WIDE ALLEY		
Project Type: Building Permission	South: Road Width - 12.0 MTR WIDE MAIN ROAD		
Nature of Development: New	East: -		
Location of Development Area: Old Area	West: -		
AREA DETAILS:			
AREA OF PLOT (Minimum)	(A)	SQ.MT.	74.25
NET AREA OF PLOT(Gross Plot Area - Deduction from Gross Plot area)	(A-Deductions)		74.25
Deduction for Balance Plot Area(from Gross Plot Area)			
Common Plot			8.71
Total			8.71
BALANCE AREA OF PLOT(Net Plot Area - Recreational/Amenity space)	(A-Deductions)		65.54
PLOT AREA FOR COVERAGE(Net Plot Area)	(A-Deductions)		74.25
Plot Area for FAR (Net Plot Area + Road Widening Area)	(A-Deductions)		74.25
COVERAGE CHECK			
Permissible Coverage area (70.00 %)			51.97
Proposed Coverage Area (58.99 %)			43.80
Total Prop. Coverage Area (58.99 %)			43.80
Balance coverage area (11.00 %)			8.17
FAR CHECK			
Perm. FAR Area (2.50)			185.63
Total Perm. FAR area			185.63
Residential FAR			87.70
Proposed FAR Area			96.87
Total Proposed FAR Area			96.87
Consumed FAR (Factor)			1.30
Balance FAR Area			88.76
BUILT UP AREA CHECK			
Total Proposed BuiltUp Area			131.50
ARCHITECT (Regd)			Amarjeet Balmuchu
ENGINEER (Regd)			
SUPERVISOR (Regd)			
OWNER (Regd)			SAHOOD AHMAD KHAN
DEVELOPMENT AUTHORITY		LOCAL BODY	

COLOR INDEX	
PLOT BOUNDARY	Black
ABUTTING ROAD	Green
PROPOSED CONSTRUCTION	Red
COMMON PLOT	Yellow
ROAD WIDENING AREA	Blue
EXISTING (To be retained)	Light Blue
EXISTING (To be demolished)	Orange

Buildingwise Floor FAR Details

Floor Name	Building Name		Total	
	A (SAHOOD AHMAD KHAN)			
	Proposed Built Up Area (Sq.mt.)	Proposed FAR Area (Sq.mt.)	Total Proposed Built Up Area (Sq.mt.)	Total FAR Area (Sq.mt.)
Ground Floor	43.80	9.17	43.80	9.17
First Floor	43.85	43.85	43.85	43.85
Second Floor	43.85	43.85	43.85	43.85
Terrace Floor	0.00	0.00	0.00	0.00
Total :	131.50	96.87	131.50	96.87

Building USE/SUBUSE Details

Building Name	Building Use	Building SubUse	Building Structure
A (SAHOOD AHMAD KHAN)	Residential	Bungalow/ Dwelling / Non Apartment	Non-Highrise

FAR & Tenement Details (Table 4c-1)

Building	No. of Same Bldg	Total Built Up Area (Sq.mt.)	Deductions (Area in Sq.mt.)		Proposed FAR Area (Sq.mt.)	Add Area In FAR (Sq.mt.)	Total FAR Area (Sq.mt.)	Total Consumed Additional FAR Area (Sq.mt.)	Tnmt (No.)
			Parking	Resi.					
A (SAHOOD AHMAD KHAN)	1	131.50	34.63	87.70	9.17	96.87	96.87	01	
Grand Total :	1	131.50	34.63	87.70	9.17	96.87	96.87	01	

LTP NAME AND SIGNATURE	STRUCTURAL ENG'S NAME AND SIGNATURE	BUILDER NAME AND SIGNATURE	DIGITAL SIGNATURE
Amarjeet Balmuchu JNAC/ARC/0008/2018			

Proposal Basic Information

Proposal File No.	JNAC/BP/0134/W4/2021
Owner Name	SAHOOD AHMAD KHAN
Khata No	2
Plot No	187
Village Name	Bisthupur
Use	Residential
SubUse	Bungalow/ Dwelling / Non Apartment

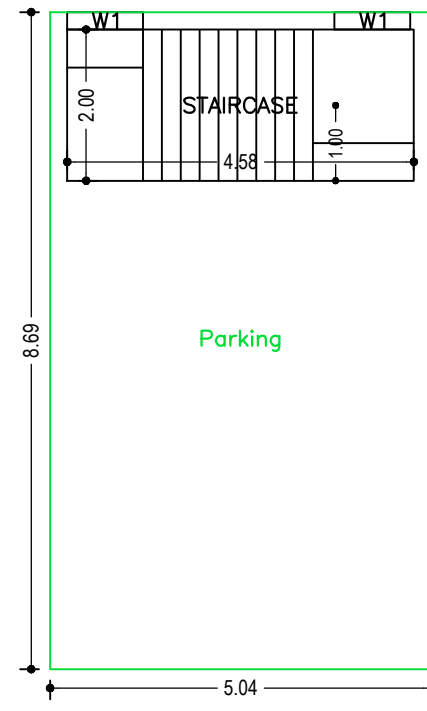

GROUND FLOOR PLAN
(SCALE 1:100)

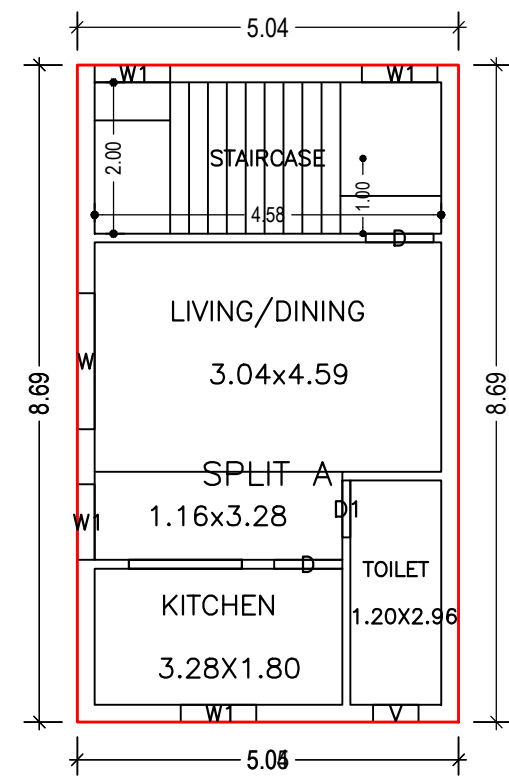

FIRST FLOOR PLAN
(Proposed)
(SCALE 1:100)

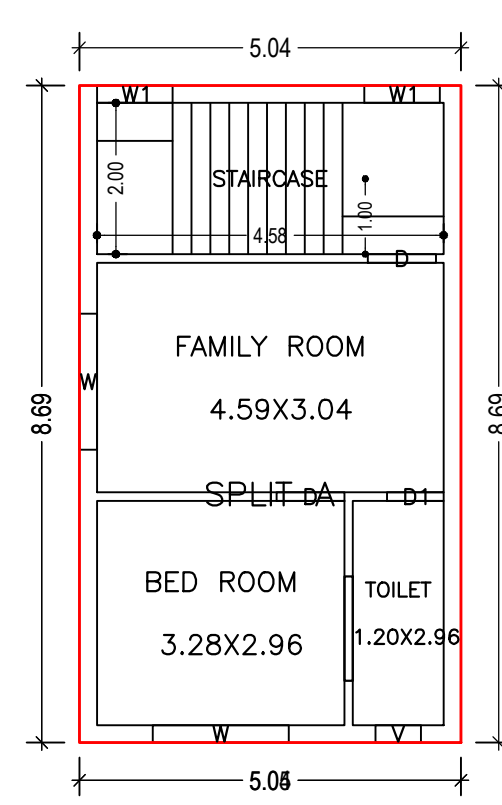

SECOND FLOOR PLAN
(Proposed)
(SCALE 1:100)

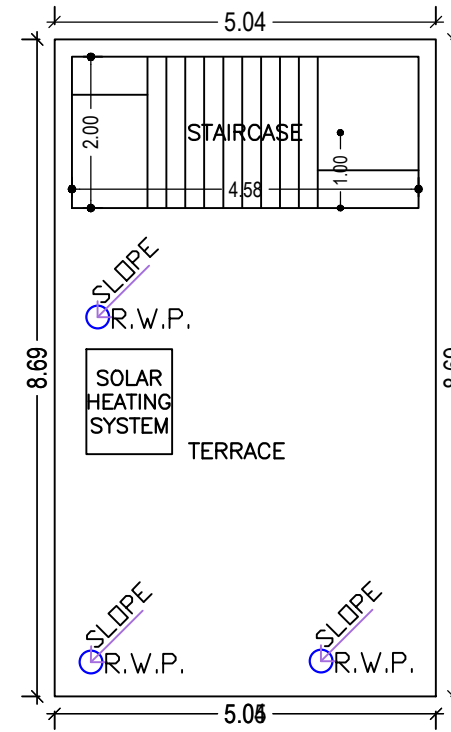

TERRACE FLOOR PLAN
(SCALE 1:100)

Building :A (SAHOOD AHMAD KHAN)

Floor Name	Total Built Up Area (Sq.mt.)	Deductions (Area in Sq.mt.)	Proposed FAR Area (Sq.mt.)	Add Area in FAR (Sq.mt.)	Total FAR Area (Sq.mt.)	Total Consumed Additional FAR Area (Sq.mt.)	Trmt (No.)
Ground Floor	43.80	34.63	0.00	9.17	9.17	9.17	00
First Floor	43.85	0.00	43.85	0.00	43.85	43.85	01
Second Floor	43.85	0.00	43.85	0.00	43.85	43.85	00
Terrace Floor	0.00	0.00	0.00	0.00	0.00	0.00	00
Total :	131.50	34.63	87.70	9.17	96.87	96.87	01
Total Number of Same Buildings	1						
Total :	131.50	34.63	87.70	9.17	96.87	96.87	01

SCHEDULE OF DOOR:

BUILDING NAME	NAME	LENGTH	HEIGHT	NOS
A (SAHOOD AHMAD KHAN)	D1	0.75	2.13	02
A (SAHOOD AHMAD KHAN)	D	0.90	2.13	04

SCHEDULE OF WINDOW/VENTILATION:

BUILDING NAME	NAME	LENGTH	HEIGHT	NOS
A (SAHOOD AHMAD KHAN)	V	0.60	2.70	02
A (SAHOOD AHMAD KHAN)	W1	1.00	2.70	08
A (SAHOOD AHMAD KHAN)	W	1.80	2.70	03

UnitBUA Table for Building :A (SAHOOD AHMAD KHAN)

FLOOR	Name	UnitBUA Type	UnitBUA Area	Carpet Area	No. of Rooms	No. of Tenement
FIRST FLOOR PLAN	SPLIT A	FLAT	56.09	55.76	3	1
SECOND FLOOR PLAN	SPLIT A	FLAT	0.00	0.00	3	0
Total:	-	-	56.09	55.76	6	1

LTP NAME AND SIGNATURE	STRUCTURAL ENG'S NAME AND SIGNATURE	BUILDER NAME AND SIGNATURE	DIGITAL SIGNATURE
Amarjeet Balmuchu JNAC/ARC/0008/2018			

Proposal Basic Information	
Proposal File No.	JNAC/BP/0134/W4/2021
Owner Name	SAHOOD AHMAD KHAN
Khata No	2
Plot No	187
Village Name	Bisthupur
Use	Residential
SubUse	Bungalow/ Dwelling / Non Apartment

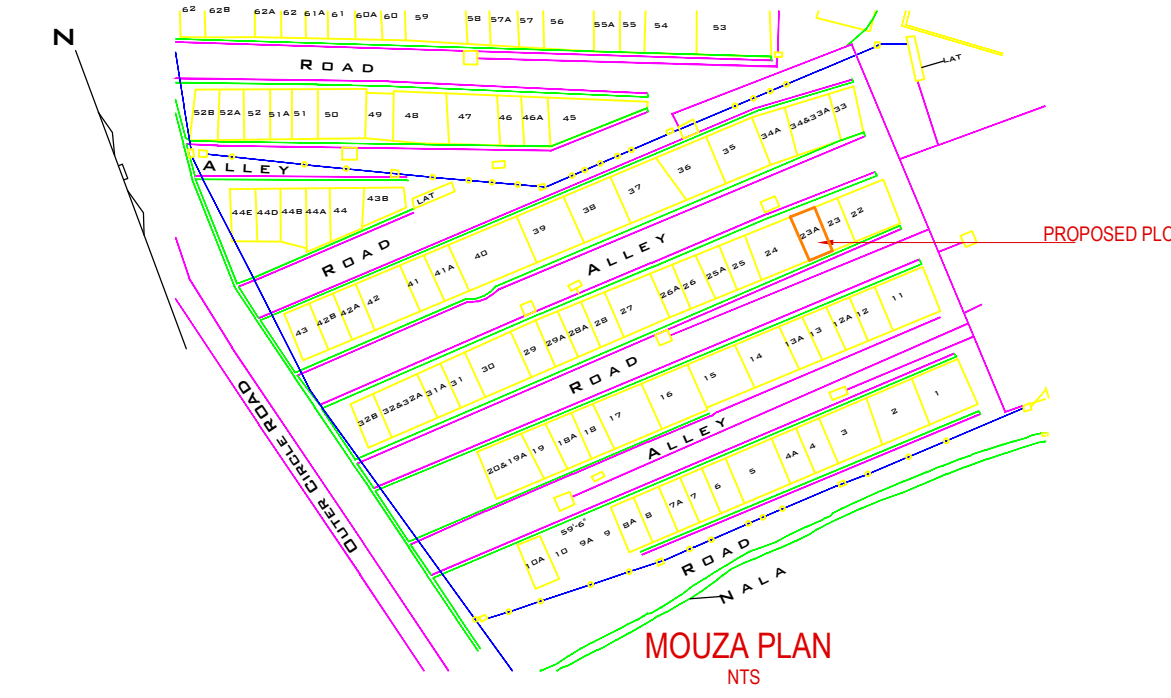
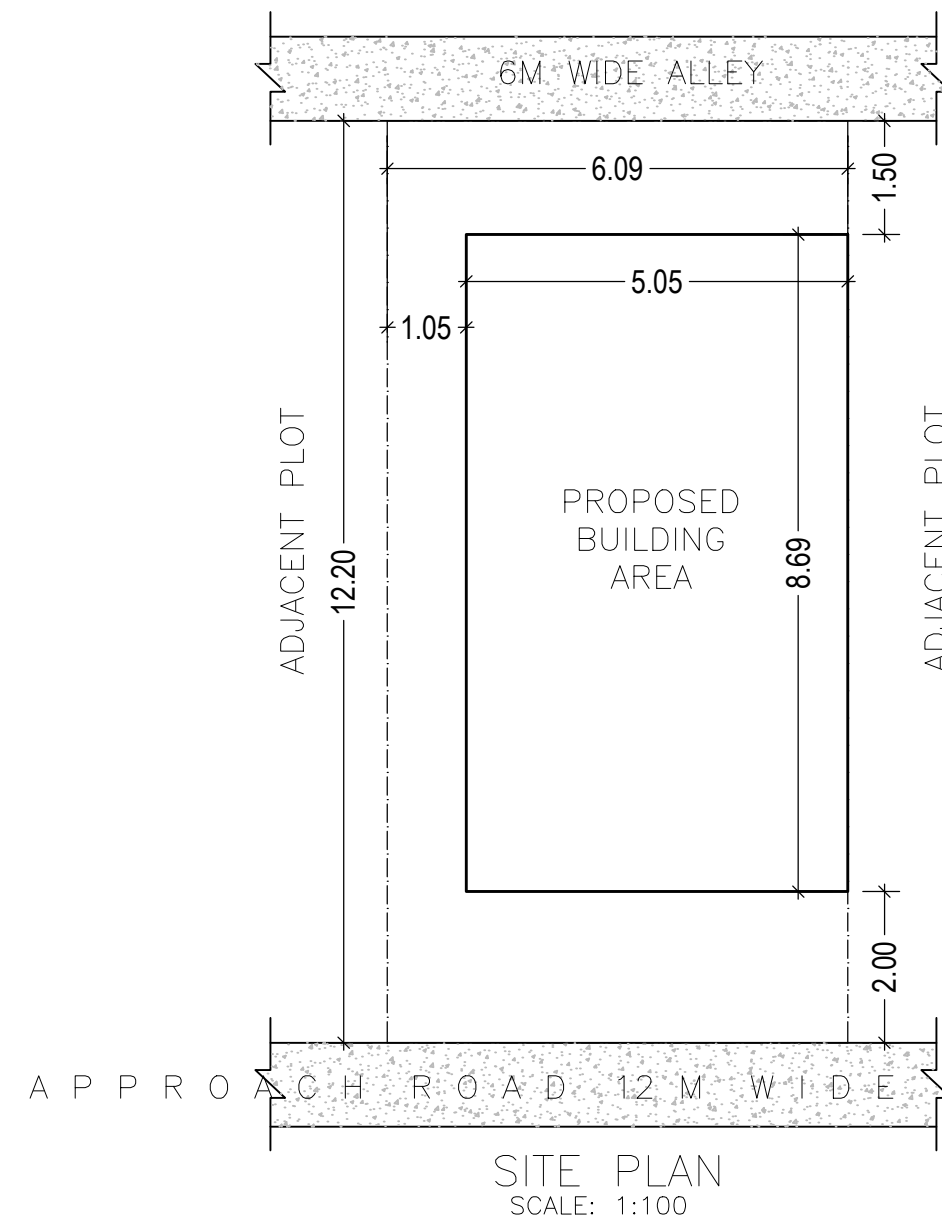
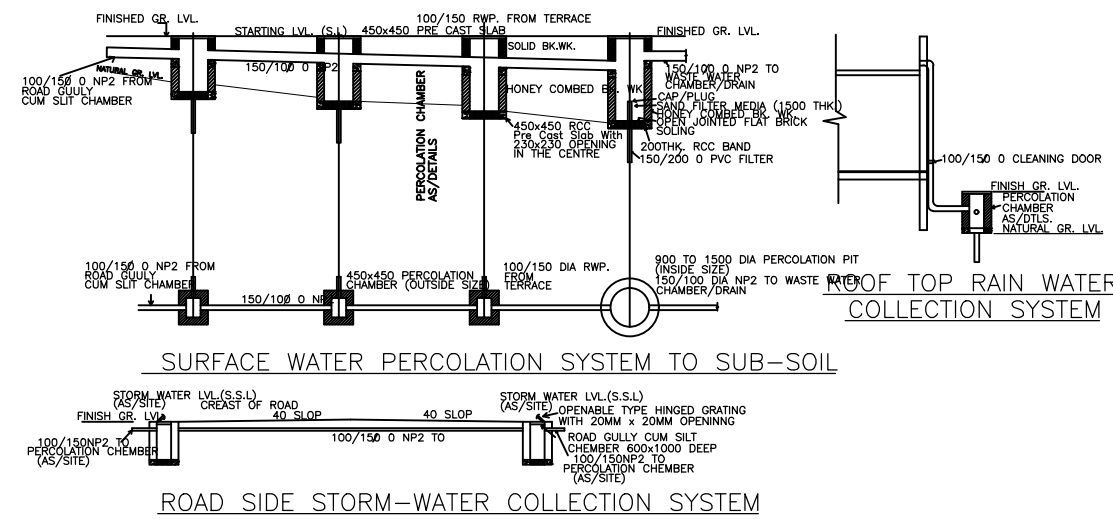
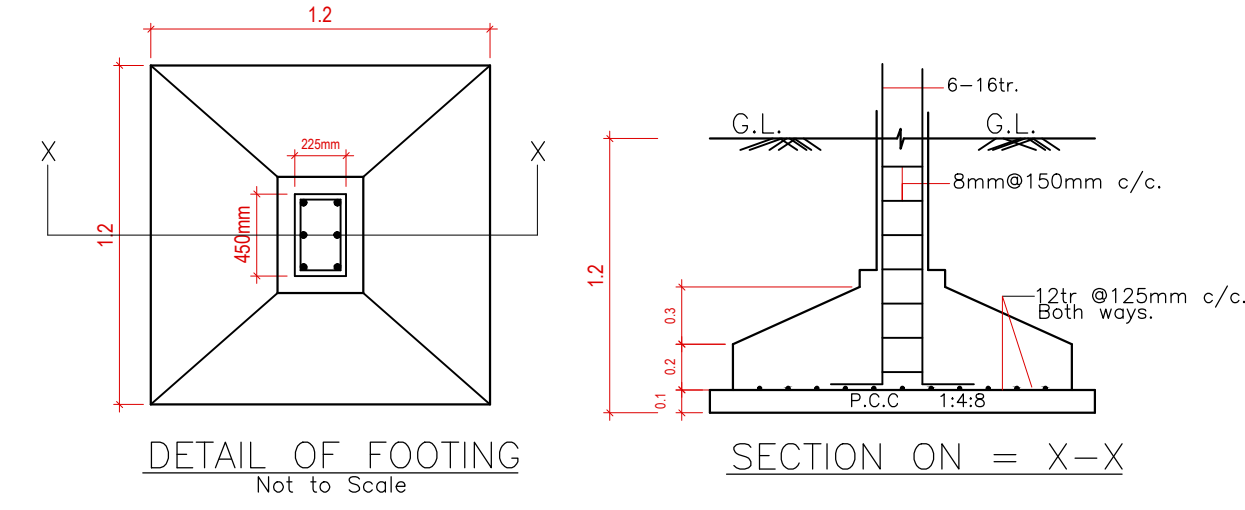
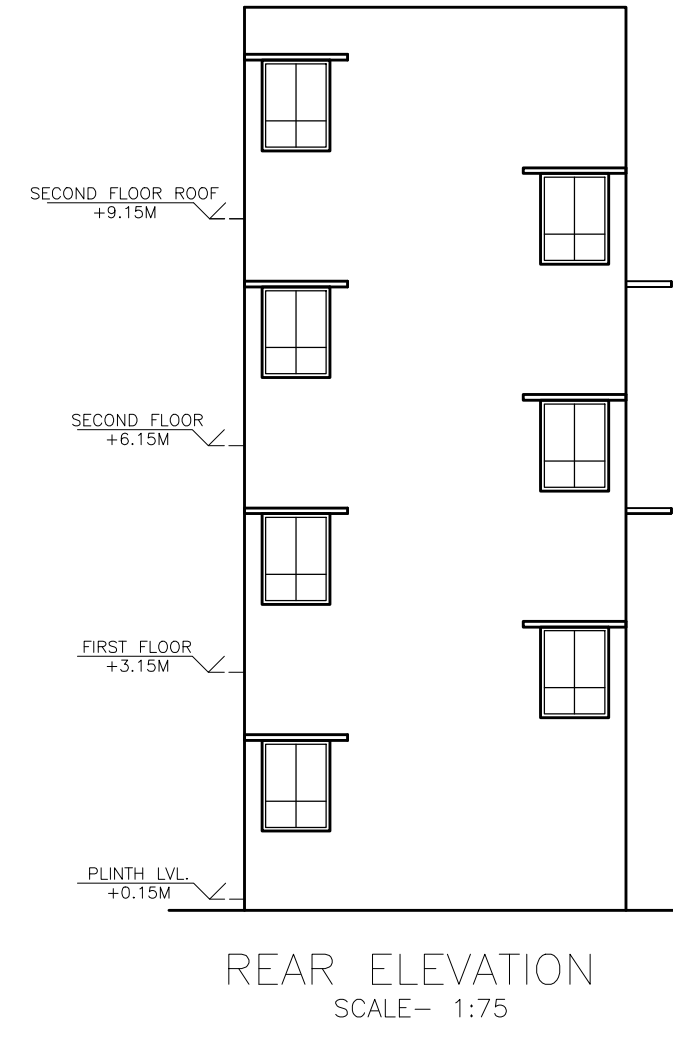
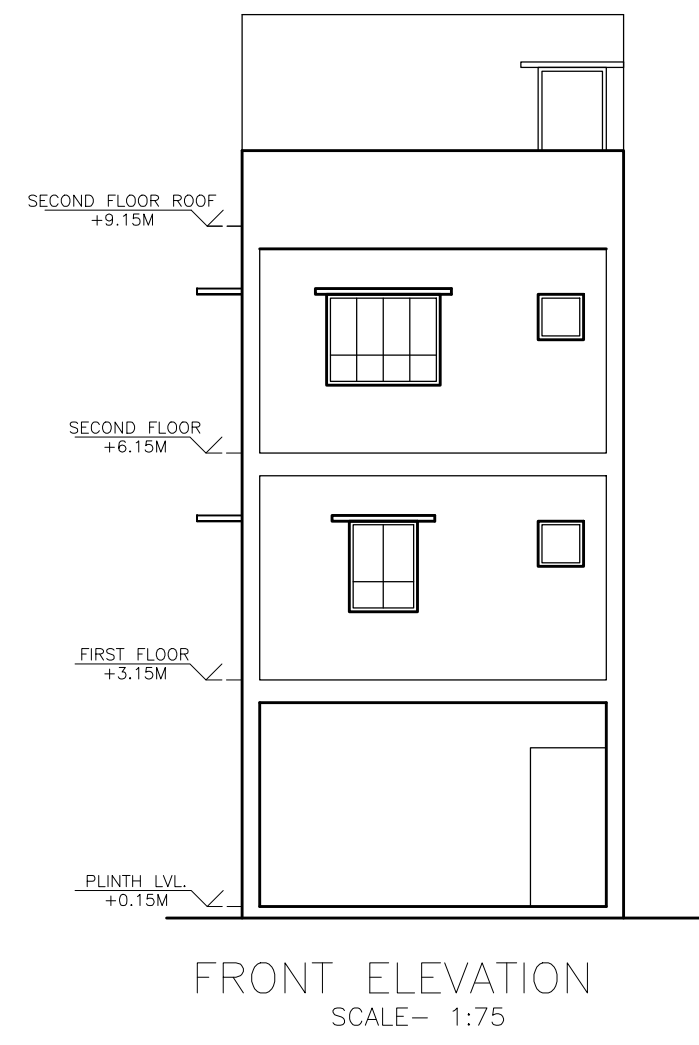
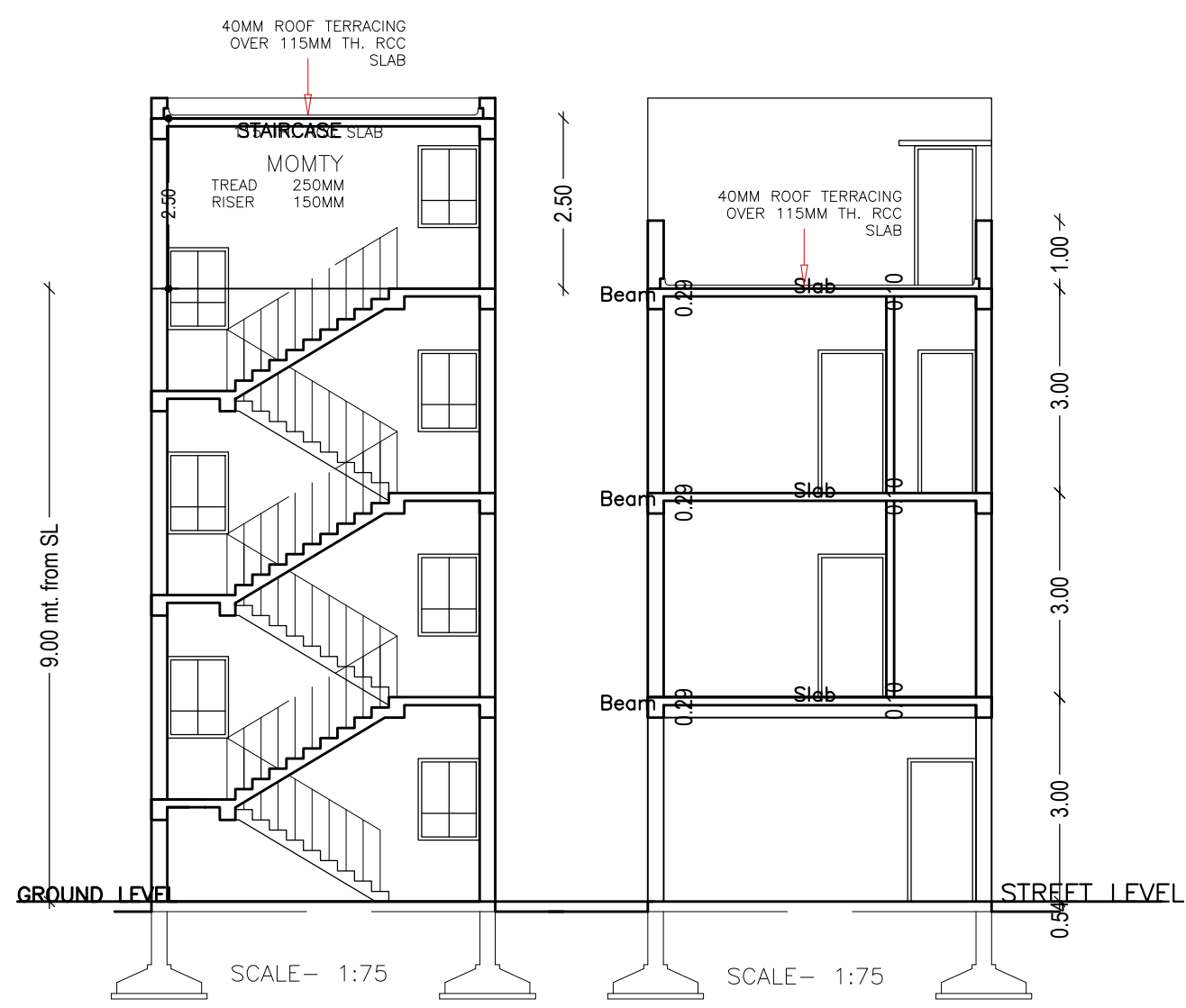

LTP NAME AND SIGNATURE	STRUCTURAL ENG'S NAME AND SIGNATURE	BUILDER NAME AND SIGNATURE	DIGITAL SIGNATURE
Amarjeet Balmuchu JNAC/ARC/0008/2018			