

SITE PLAN
SCALE=1:100

SITE PLAN

FAR & Tenement Details (Table 4c-1)

Building	No. of Same Bldg	Total Built Up Area (Sq.mt.)	Deductions (Area in Sq.mt.)	Proposed FAR Area (Sq.mt.)	Add Area In FAR (Sq.mt.)	Total Consumed Additional FAR Area (Sq.mt.)	Tnmt (No.)
A (FULKANT SINGH)	1	223.11	63.21	148.74	11.16	159.90	01
Grand Total :	1	223.11	63.21	148.74	11.16	159.90	01

Proposal Basic Information

Proposal File No.	JNAC/EP/0007/W9/2021
Owner Name	FUL KANT SINGH
Khata No	NIL
Plot No	148
Village Name	SAKCHI
Use	Residential
SubUse	Row House

AREA STATEMENT JAMSHEDPUR NAC	VERSION NO.: 1.0.62 VERSION DATE: 16/10/2020	
PROJECT DETAIL:		
Region: JHARKHAND URBAN LOCAL BODIES	Plot Use: Residential	
District: EAST SINGHBHUM	Plot SubUse: Row House	
Authority: JAMSHEDPUR NAC	PlotNearby/ReligiousStructure: NA	
Inward_No: JNAC/EP/0007/W9/2021	PlotSubPlot No: 148	
Application Type: General Proposal	North: Road Width - 9.10	
Project Type: Building Permission	South: Road Width - 4.50	
Nature of Development: New	East: Road Width - 6.10	
Location of Development Area: Old Area	West: Plot No. - 155	
AREA DETAILS:		
AREA OF PLOT (Minimum)	(A)	SQ.MT.
NET AREA OF PLOT(Gross Plot Area - Deduction from Gross Plot area)	(A-Deductions)	115.16
Deduction for Balance Plot Area(from Gross Plot Area)		
Common Plot		9.18
Total		9.18
BALANCE AREA OF PLOT(Net Plot Area - Recreational/Amenity space)	(A-Deductions)	105.98
PLOT AREA FOR COVERAGE(Net Plot Area)	(A-Deductions)	115.16
Plot Area for FAR (Net Plot Area + RoadWidening Area)	(A-Deductions)	115.16
COVERAGE CHECK		
Permissible Coverage area (70.00 %)		80.61
Proposed Coverage Area (64.58 %)		74.37
Total Prop. Coverage Area (64.58 %)		74.37
Balance coverage area (5.42 %)		6.24
FAR CHECK		
Perm. FAR Area (2.50)		287.90
Total Perm. FAR area		287.90
Residential FAR		148.74
Proposed FAR Area		159.90
Total Proposed FAR Area		159.90
Consumed FAR (Factor)		1.39
Balance FAR Area		128.00
BUILT UP AREA CHECK		
Total Proposed BuiltUp Area		223.11
ARCHITECT (Regd)		SHREYASHI PAUL
ENGINEER (Regd)		
SUPERVISOR (Regd)		
OWNER (Regd)		FUL KANT SINGH
DEVELOPMENT AUTHORITY		LOCAL BODY

COLOR INDEX	
PLOT BOUNDARY	Black
ABUTTING ROAD	Green
PROPOSED CONSTRUCTION	Red
COMMON PLOT	Yellow
ROAD WIDENING AREA	Blue
EXISTING (To be retained)	Light Blue
EXISTING (To be demolished)	Light Yellow

Buildingwise Floor FAR Details

Floor Name	Building Name A (FULKANT SINGH)		Total	
	Proposed Built Up Area (Sq.mt.)	Proposed FAR Area (Sq.mt.)	Total Proposed Built Up Area (Sq.mt.)	Total FAR Area (Sq.mt.)
Parking Floor	74.37	11.16	74.37	11.16
First Floor	74.37	74.37	74.37	74.37
Second Floor	74.37	74.37	74.37	74.37
Terrace Floor	0.00	0.00	0.00	0.00
Total :	223.11	159.90	223.11	159.90

Building USE/SUBUSE Details

Building Name	Building Use	Building SubUse	Building Structure
A (FULKANT SINGH)	Residential	Row House	Non-Highrise

LTP NAME AND SIGNATURE	STRUCTURAL ENG'S NAME AND SIGNATURE	BUILDER NAME AND SIGNATURE	DIGITAL SIGNATURE
SHREYASHI PAUL JNAC/DFTMN/0009/2016			

Proposal Basic Information

Proposal File No.	JNAC/FTM/0007/W9/2021
Owner Name	FUL KANT SINGH
Khata No	NIL
Plot No	148
Village Name	SAKCHI
Use	Residential
SubUse	Row House

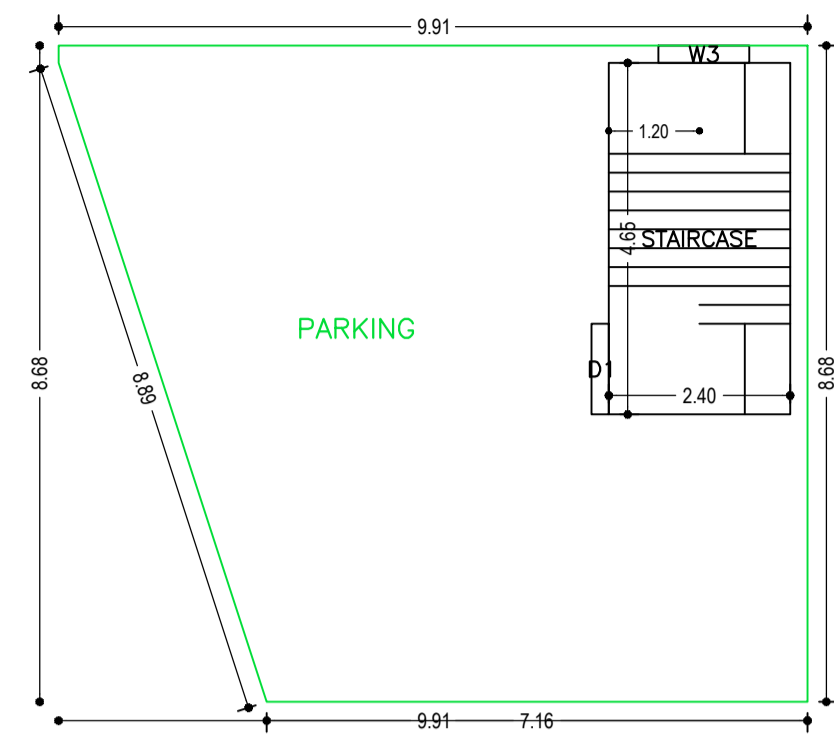

PARKING FLOOR PLAN
(SCALE 1:100)

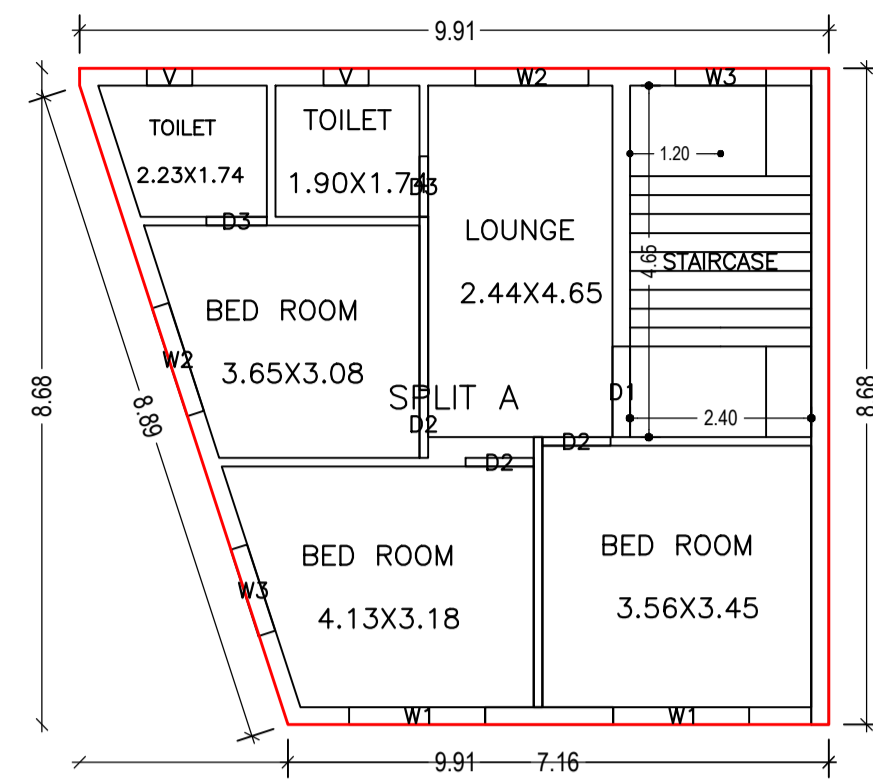

SECOND FLOOR PLAN
(Proposed)
(SCALE 1:100)

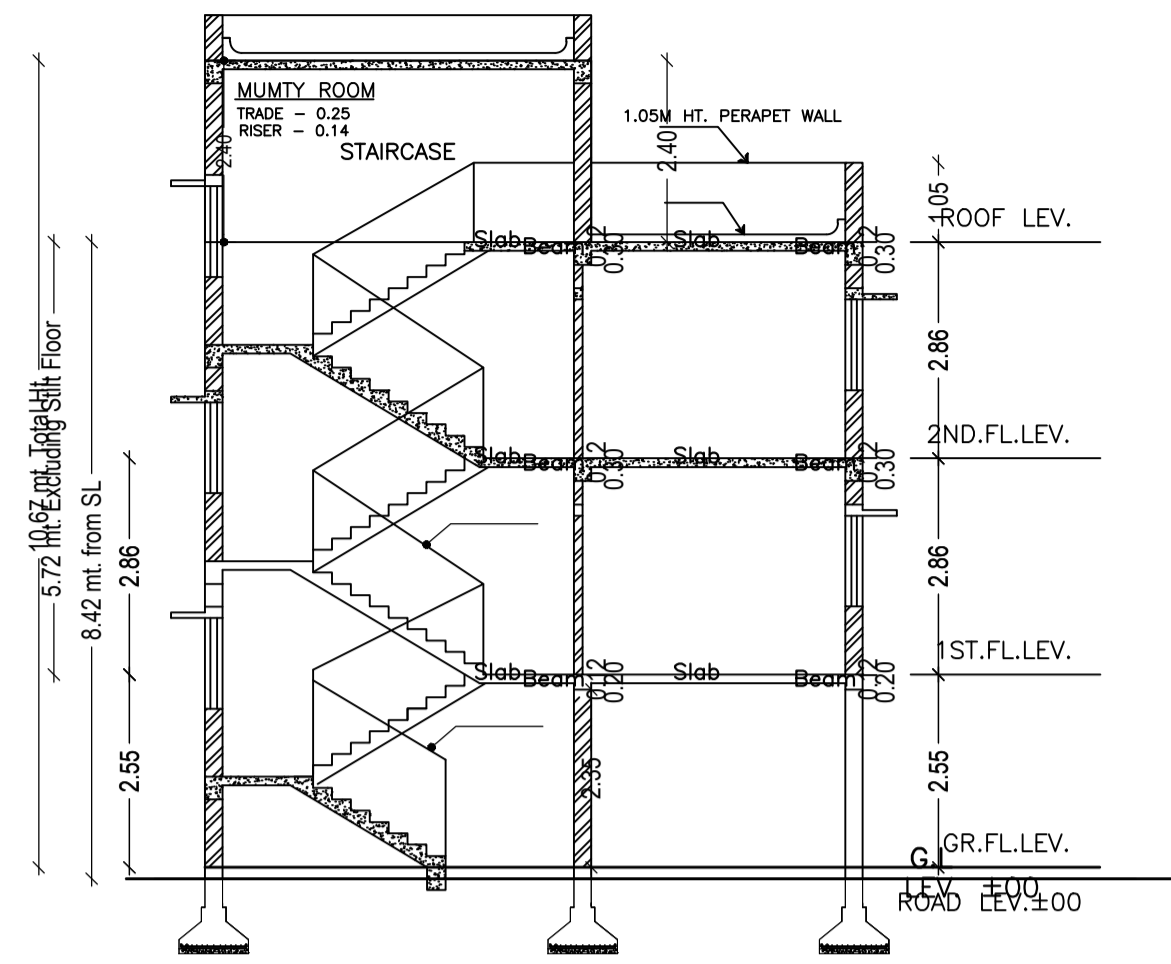

SECTION -X-X
SCALE- 1:100

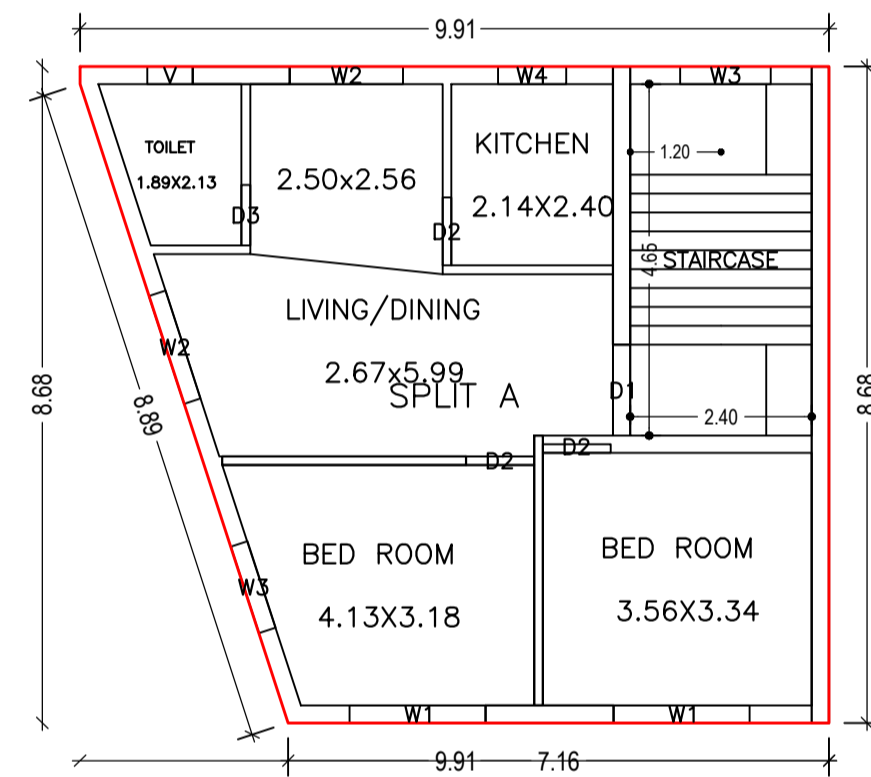

FIRST FLOOR PLAN
(Proposed)
(SCALE 1:100)

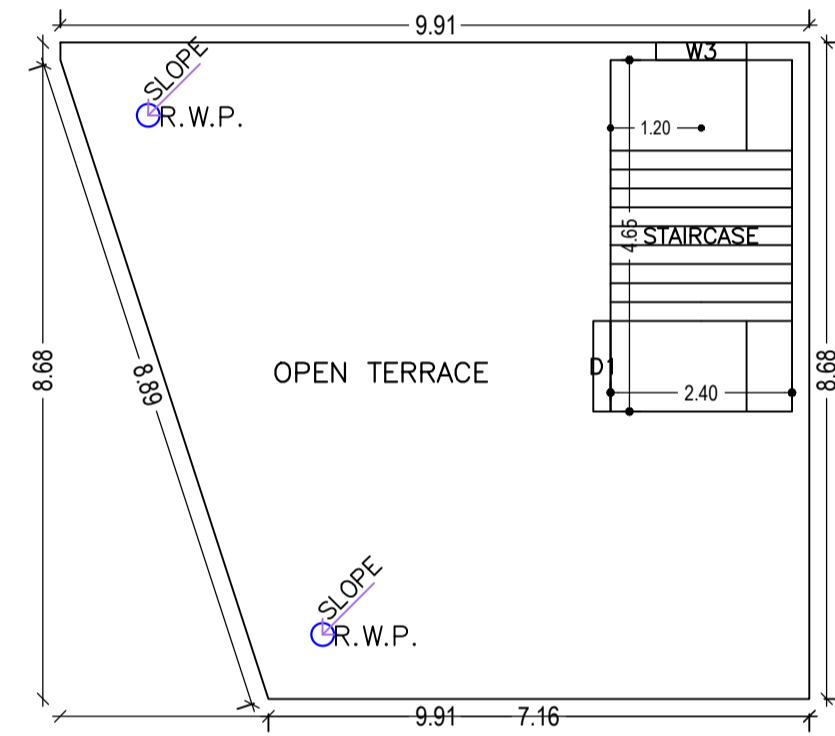

TERRACE FLOOR PLAN
(SCALE 1:100)

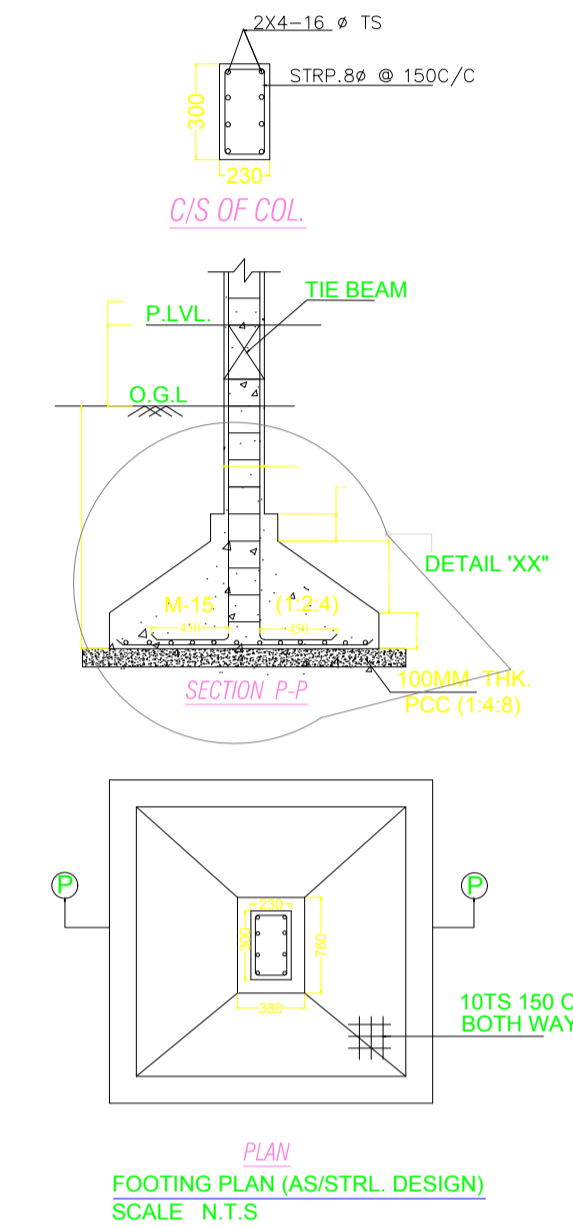

PLAN
FOOTING PLAN (AS/STR/L DESIGN)
SCALE N.T.S

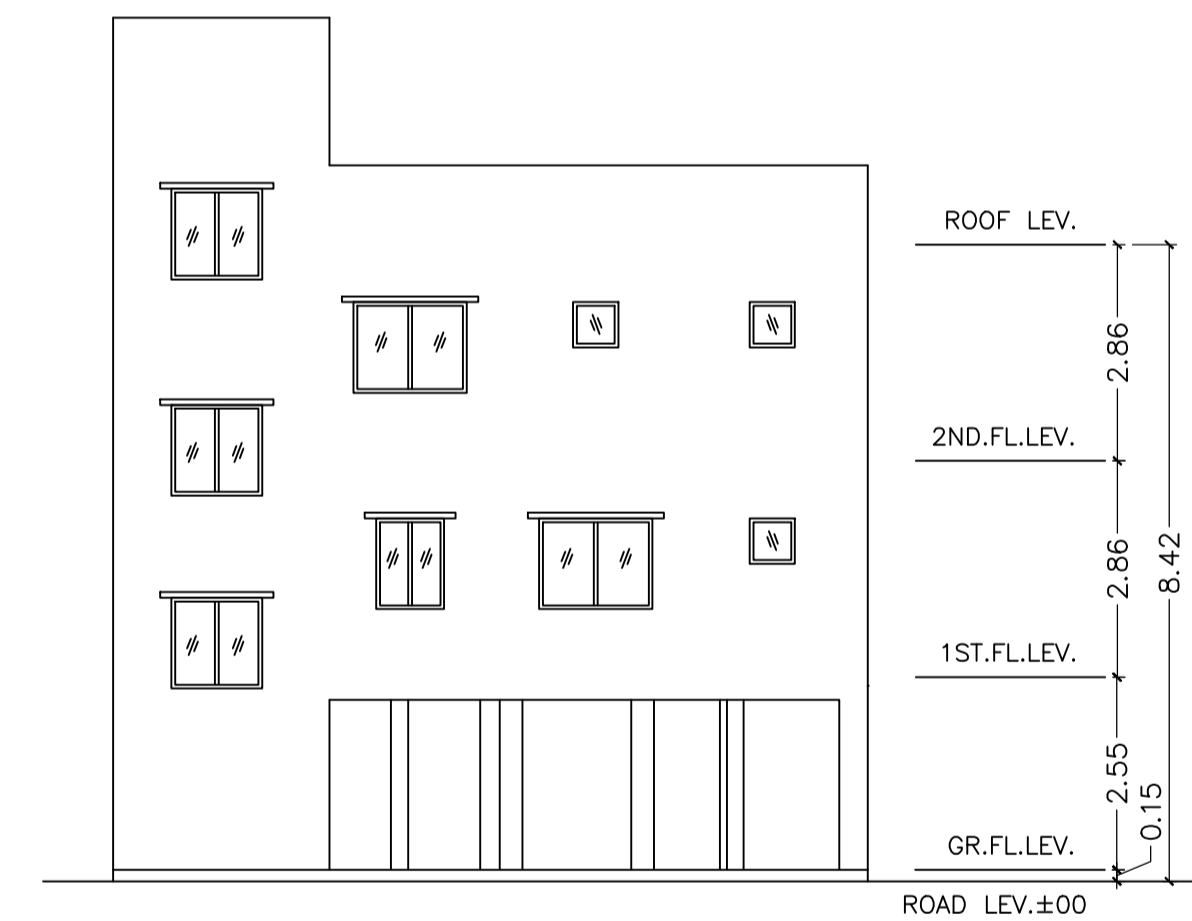

REAR SIDE ELEVATION
SCALE- 1:100

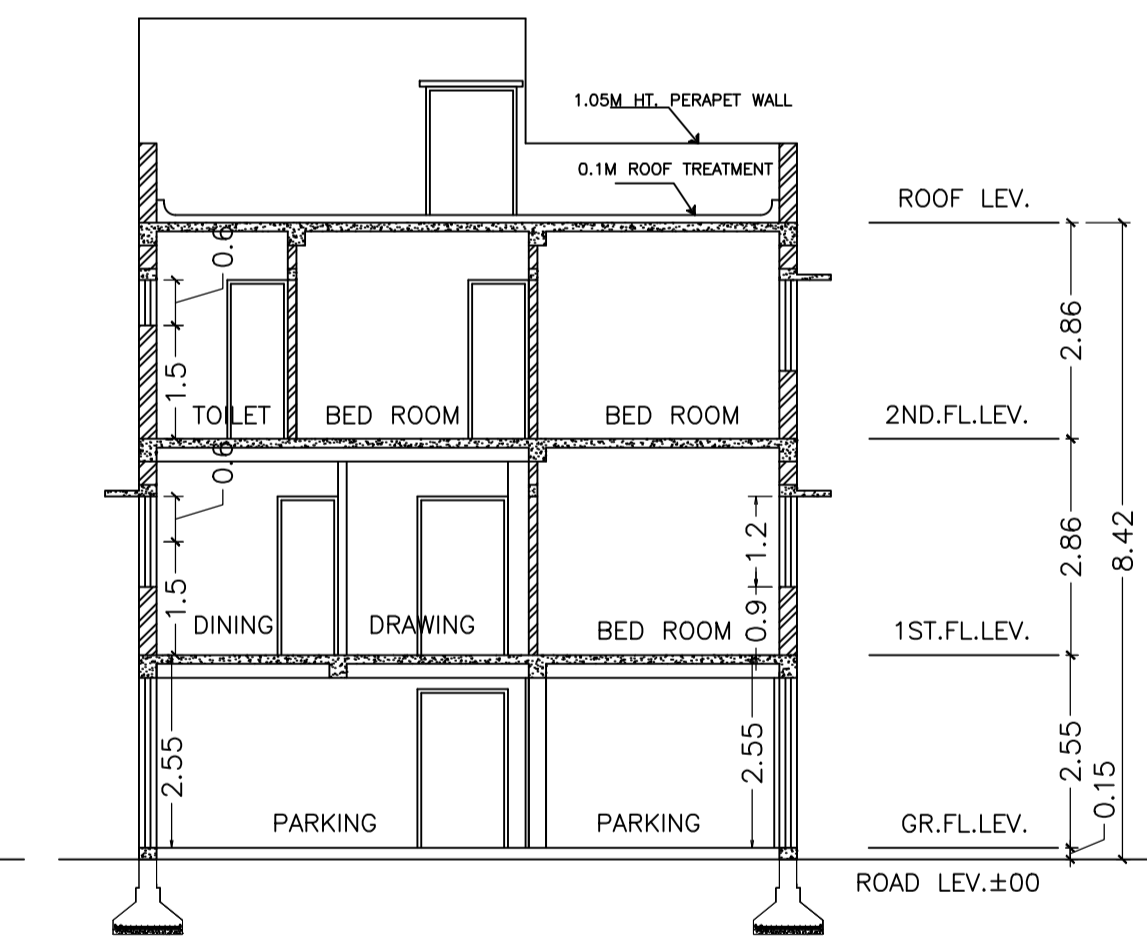

SECTION -Y-Y
SCALE- 1:100

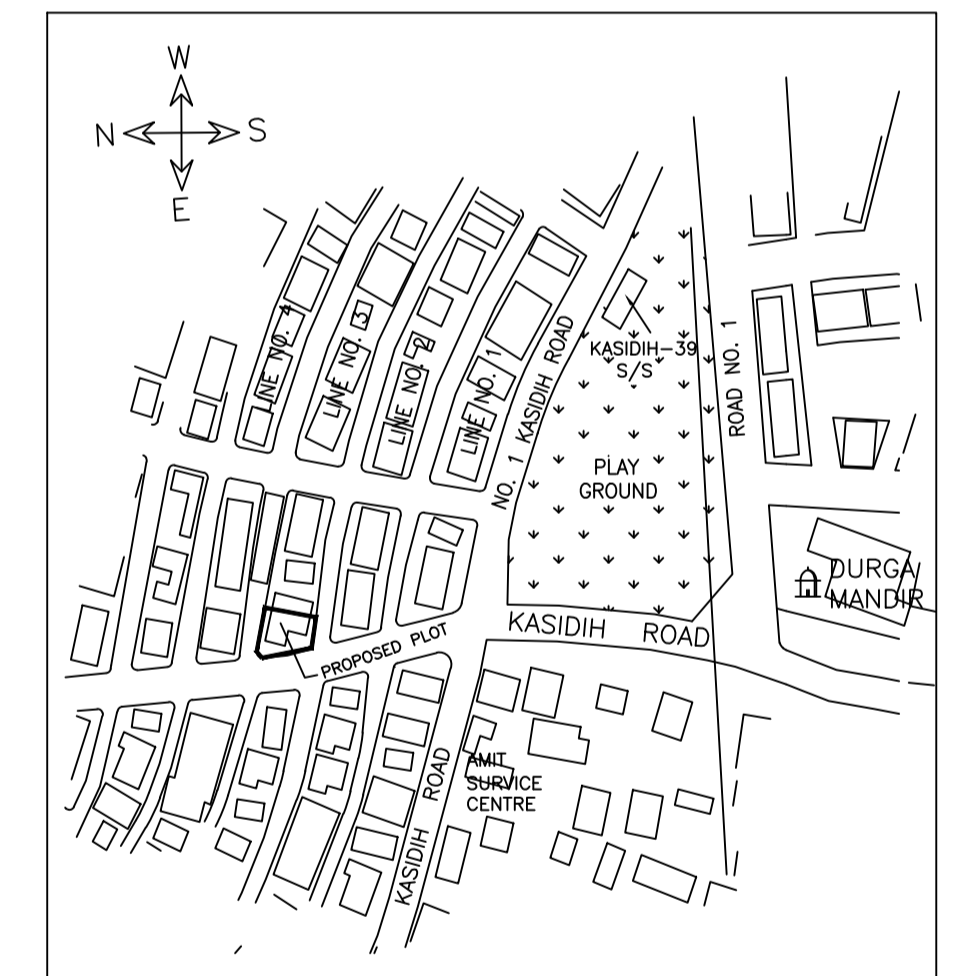

Building :A (FULKANT SINGH)

Floor Name	Total Built Up Area (Sq.mt.)	Deductions (Area in Sq.mt.)		Proposed FAR Area (Sq.mt.)		Total FAR Area (Sq.mt.)	Total Consumed Additional FAR Area (Sq.mt.)	Trmt (No.)
		Parking	Resi.	Stair	Stair			
Parking Floor	74.37	63.21	0.00	11.16	11.16	11.16	0.00	00
First Floor	74.37	0.00	74.37	0.00	74.37	74.37	0.00	01
Second Floor	74.37	0.00	74.37	0.00	74.37	74.37	0.00	00
Terrace Floor	0.00	0.00	0.00	0.00	0.00	0.00	0.00	00
Total :	223.11	63.21	148.74	11.16	159.90	159.90	0.00	01
Total Number of Same Buildings	1							
Total :	223.11	63.21	148.74	11.16	159.90	159.90	0.00	01

SCHEDULE OF DOOR:

BUILDING NAME	NAME	LENGTH	HEIGHT	NOS
A (FULKANT SINGH)	D3	0.80	2.10	03
A (FULKANT SINGH)	D2	0.90	2.10	06
A (FULKANT SINGH)	D1	1.20	2.10	02

SCHEDULE OF WINDOW/VENTILATION:

BUILDING NAME	NAME	LENGTH	HEIGHT	NOS
A (FULKANT SINGH)	V	0.60	0.60	03
A (FULKANT SINGH)	W4	0.90	1.20	01
A (FULKANT SINGH)	W3	1.20	1.20	06
A (FULKANT SINGH)	W2	1.50	1.20	04
A (FULKANT SINGH)	W1	1.80	1.20	04

UnitBUA Table for Building :A (FULKANT SINGH)

FLOOR	Name	UnitBUA Type	UnitBUA Area	Carpet Area	No. of Rooms	No. of Tenement
FIRST FLOOR PLAN	SPLIT A	FLAT	148.74	141.37	5	1
SECOND FLOOR PLAN	SPLIT A	FLAT	0.00	0.00	6	0
Total:	-	-	148.74	141.37	11	1

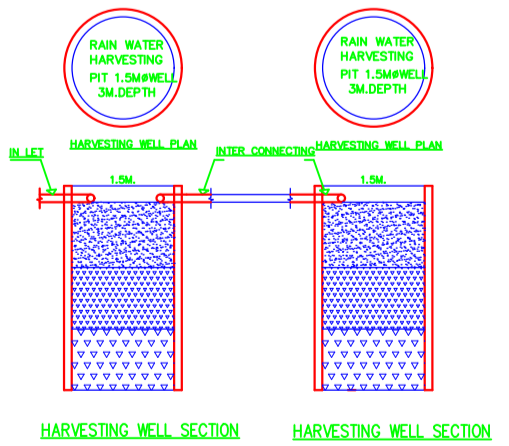

HARVESTING WELL SECTION HARVESTING WELL SECTION

LTP NAME AND SIGNATURE	STRUCTURAL ENG'S NAME AND SIGNATURE	BUILDER NAME AND SIGNATURE	DIGITAL SIGNATURE
SHREYASHI PAUL JNAC/DFT/MN/0009/2016			

Proposal Basic Information	
Proposal File No.	JNAC/FTM/0007/W9/2021
Owner Name	FUL KANT SINGH
Khata No	NIL
Plot No	148
Village Name	SAKCHI
Use	Residential
SubUse	Row House

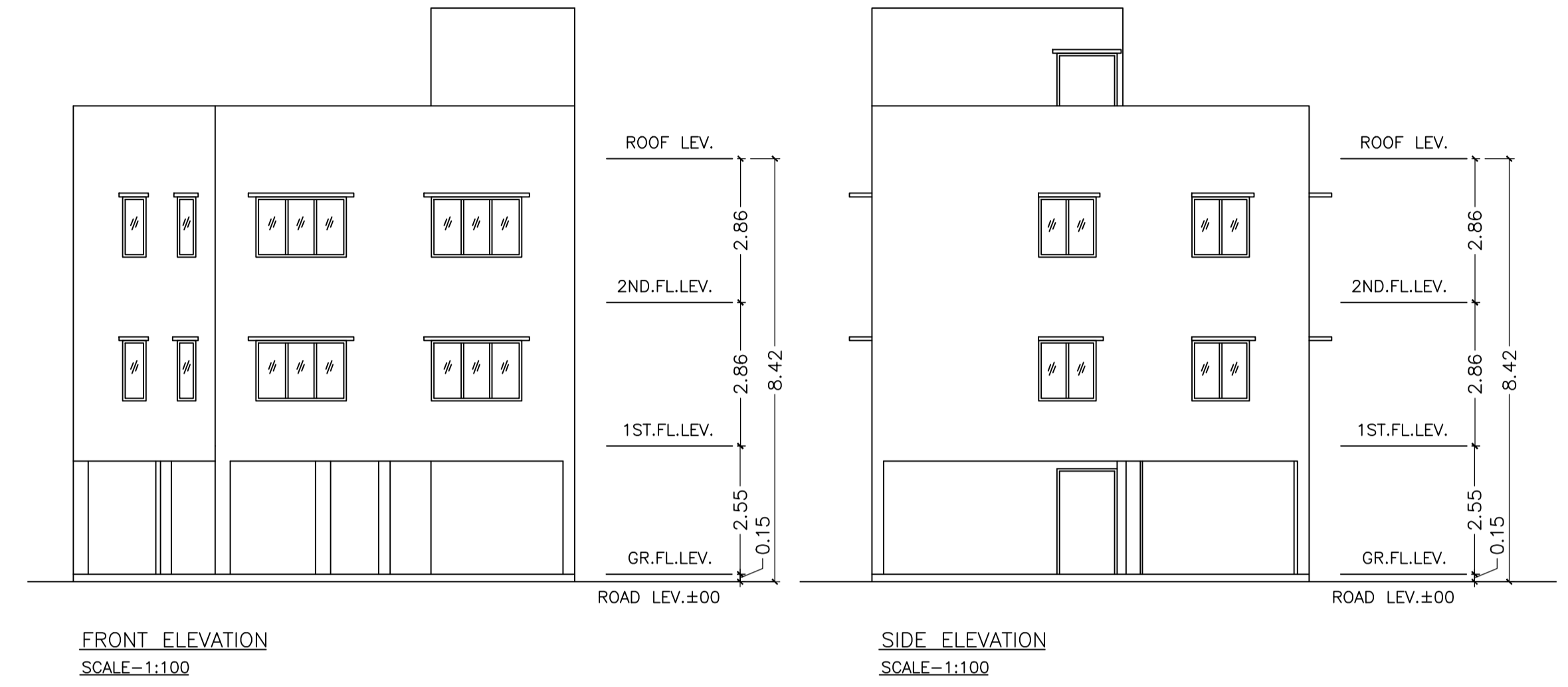

LTP NAME AND SIGNATURE	STRUCTURAL ENG'S NAME AND SIGNATURE	BUILDER NAME AND SIGNATURE	DIGITAL SIGNATURE
SHREYASHI PAUL JNAC/DFTMN/0009/2016			