

Proposal Basic Information	
Proposal File No.	JNAC/BP/0073/W3/2021
Owner Name	MUNNI LAL AND MAHESH PRASAD
Khata No	85
Plot No	2681
Village Name	KHUNTADIH
Use	Residential
SubUse	Bungalow/ Dwelling / Non Apartment

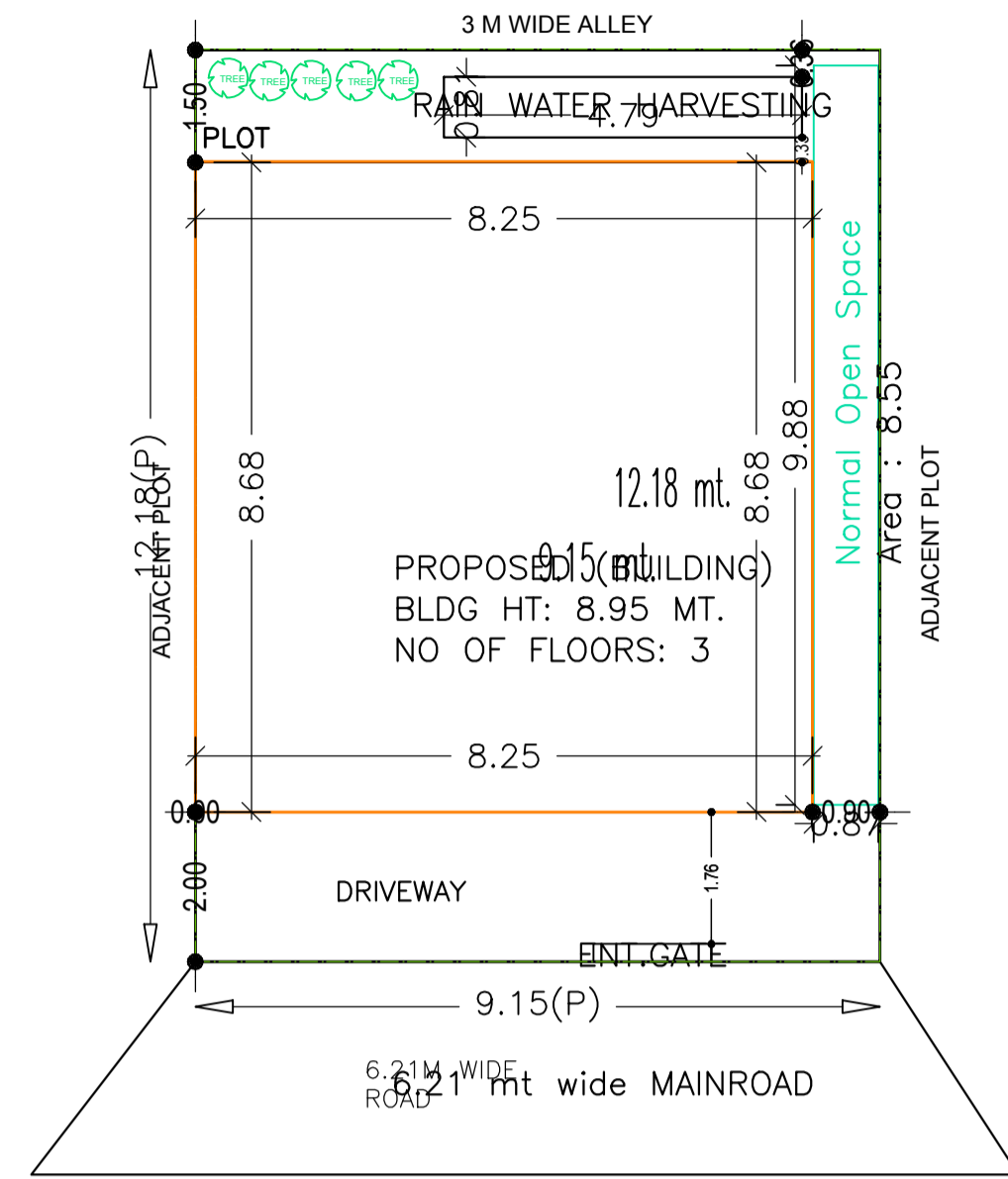

SITE PLAN  
SCALE -  
1:150

AREA STATEMENT		VERSION NO. : 1.0.61
PROJECT DETAIL:		VERSION DATE: 16/10/2020
Region: JHARKHAND URBAN LOCAL BODIES	Plot Use: Residential	
District: EAST SINGHBHUM	Plot SubUse: Bungalow/ Dwelling / Non Apartment	
Authority: JAMSHEDPUR NAC	Plot/Nearby/Religious/Structure: NA	
Inward_No.: JNAC/BP/0073/W3/2021	Plot/SubPlot No.: 2681	
Application Type: General Proposal	North: Survey No. - 11	
Project Type: Building Permission	South: Survey No. - 09	
Nature of Development: New	East: Road Width - 9.1	
Location of Development Area: Old Area	West: Survey No. - ALLEY	
AREA DETAILS:		SQ.MT.
AREA OF PLOT (Minimum)	(A)	
NET AREA OF PLOT (Gross Plot Area - Deduction from Gross Plot area)	(A-Deductions)	111.40
Deduction for Balance Plot Area (from Gross Plot Area)		
Common Plot		8.55
BALANCE AREA OF PLOT (Net Plot Area - Recreational/Amenity space)	(A-Deductions)	8.55
PLOT AREA FOR COVERAGE (Net Plot Area)		111.40
Plot Area for FAR (Net Plot Area + Road Widening Area)	(A-Deductions)	111.40
COVERAGE CHECK		
Permissible Coverage area ( 70.00 % )		77.98
Total Prop. Coverage Area ( 64.26 % )		71.58
Balance coverage area ( 5.75 % )		6.40
FAR CHECK		
Perm. FAR Area ( 2.50 )		278.50
Total Perm. FAR area		278.50
Proposed FAR Area		154.74
Total Proposed FAR Area		154.74
Consumed FAR (Factor)		1.39
Balance FAR Area		123.76
BUILT UP AREA CHECK		214.74
Total Proposed BuiltUp Area		214.74
ARCHITECT (Regd)	Amarjeet Balmuchu	
ENGINEER (Regd)		
SUPERVISOR (Regd)		
OWNER (Regd)	MUNNI LAL AND MAHESH PRASAD	
DEVELOPMENT AUTHORITY		LOCAL BODY

COLOR INDEX	
PLOT BOUNDARY	[Green Line]
ABUTTING ROAD	[Red Line]
PROPOSED CONSTRUCTION	[Yellow Line]
COMMON PLOT	[Blue Line]
ROAD WIDENING AREA	[Orange Line]
EXISTING (To be retained)	[Grey Line]
EXISTING (To be demolished)	[Black Line]

Buildingwise Floor FAR Details

Floor Name	Building Name		Total	
	Proposed Built Up Area (Sq.mt.)	Proposed FAR Area (Sq.mt.)	Total Proposed Built Up Area (Sq.mt.)	Total FAR Area (Sq.mt.)
Ground Floor	71.58	11.59	71.58	11.59
First Floor	71.58	71.58	71.58	71.58
Second Floor	71.58	71.58	71.58	71.58
Terrace Floor	0.00	0.00	0.00	0.00
Total	214.74	154.75	214.74	154.75

Building USE/SUBUSE Details

Building Name	Building Use	Building SubUse	Building Structure
PROPOSED (BUILDING)	Residential	Bungalow/ Dwelling / Non Apartment	Non-Highrise

Required Parking (Table 7a)

Building Name	Type	SubUse	Area (Sq.mt.)	Units		Car		Visitors Car			
				Reqd.	Prop.	Reqd./Unit	Reqd.	Prop.	Reqd./Unit	Reqd.	Prop.
PROPOSED (BUILDING)	Residential	Bungalow/ Dwelling / Non Apartment	> 0	1	2.00	1.00	2	-	-	-	-
			> 0	1	2.00	-	-	1	1	1	1
Total			-	-	-	-	2	2	-	1	1

Parking Check (Table 7b)

Vehicle Type	Reqd.		Prop.	
	No.	Area	No.	Area
Car	-	-	2	25.00
Total Car	2	25.00	2	25.00
Visitor's Car Parking	-	-	1	12.50
Total Visitor Parking	1	12.50	1	12.50
Other Parking	-	-	-	22.49
Total		37.50		59.99

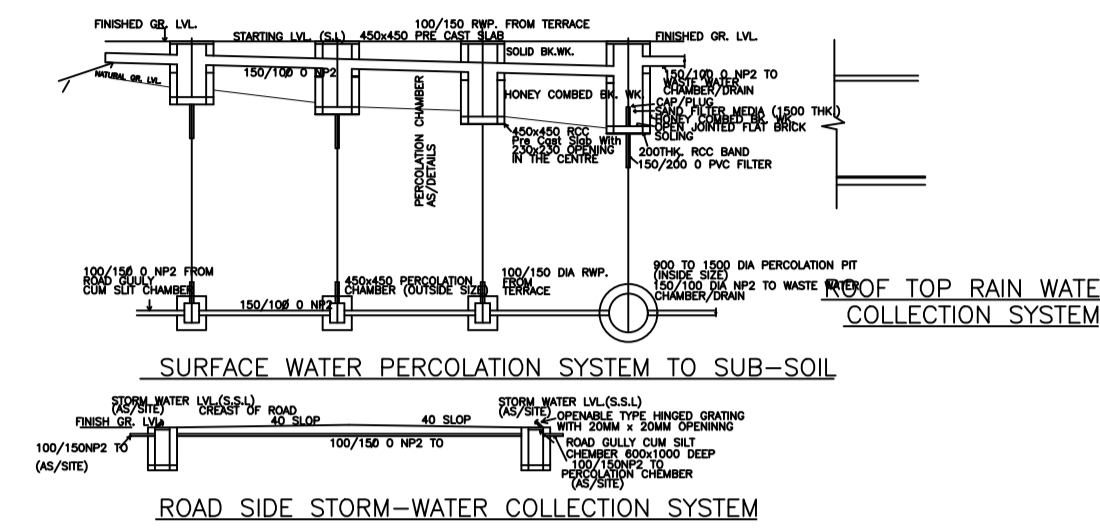

FAR & Tenement Details (Table 4c-1)

Building	No. of Same Bldg	Total Built Up Area (Sq.mt.)	Deductions (Area in Sq.mt.)		Proposed FAR Area (Sq.mt.)	Total FAR Area (Sq.mt.)	Total Consumed Additional FAR Area (Sq.mt.)	Tnmt (No.)
			Parking	Resi.				
PROPOSED (BUILDING)	1	214.74	59.99	154.75	154.75	154.75	154.75	02
Grand Total :	1	214.74	59.99	154.75	154.75	154.75	154.75	02

Building :PROPOSED (BUILDING)

Floor Name	Total Built Up Area (Sq.mt.)	Deductions (Area in Sq.mt.)		Proposed FAR Area (Sq.mt.)	Total FAR Area (Sq.mt.)	Total Consumed Additional FAR Area (Sq.mt.)	Tnmt (No.)
		Parking	Resi.				
Ground Floor	71.58	59.99	11.59	11.59	11.59	11.59	01
First Floor	71.58	0.00	71.58	71.58	71.58	71.58	00
Second Floor	71.58	0.00	71.58	71.58	71.58	71.58	01
Terrace Floor	0.00	0.00	0.00	0.00	0.00	0.00	00
Total :	214.74	59.99	154.75	154.75	154.75	154.75	02
Total Number of Same Buildings :	1						
Total :	214.74	59.99	154.75	154.75	154.75	154.75	02

SCHEDULE OF DOOR:

BUILDING NAME	NAME	LENGTH	HEIGHT	NOS
PROPOSED (BUILDING)	D3	0.75	2.10	02
PROPOSED (BUILDING)	D2	0.90	2.10	08
PROPOSED (BUILDING)	D2	1.00	2.10	02

SCHEDULE OF WINDOW/VENTILATION:

BUILDING NAME	NAME	LENGTH	HEIGHT	NOS
PROPOSED (BUILDING)	V	0.60	1.20	02
PROPOSED (BUILDING)	W1	0.90	1.20	04
PROPOSED (BUILDING)	W2	1.50	1.20	04
PROPOSED (BUILDING)	MECH VENT	1.80	1.20	02

UnitBUA Table for Building :PROPOSED (BUILDING)

FLOOR	Name	UnitBUA Type	UnitBUA Area	Carpet Area	No. of Rooms	No. of Tenement
GROUND FLOOR PLAN	SPLIT A	FLAT	75.02	73.49	0	1
FIRST FLOOR PLAN	SPLIT A	FLAT	0.00	0.00	5	0
SECOND FLOOR PLAN	SPLIT B	FLAT	64.00	63.45	5	1
Total:	-	-	139.02	136.94	10	2

LTP NAME AND SIGNATURE	STRUCTURAL ENG'S NAME AND SIGNATURE	BUILDER NAME AND SIGNATURE	DIGITAL SIGNATURE
Amarjeet Balmuchu JNAC/ARC/0008/2018			

Proposal Basic Information

Proposal File No.	JNAC/BP/0073/W3/2021
Owner Name	MUNNI LAL AND MAHESH PRASAD
Khata No	85
Plot No	2681
Village Name	KHUNTADIH
Use	Residential
SubUse	Bungalow/ Dwelling / Non Apartment

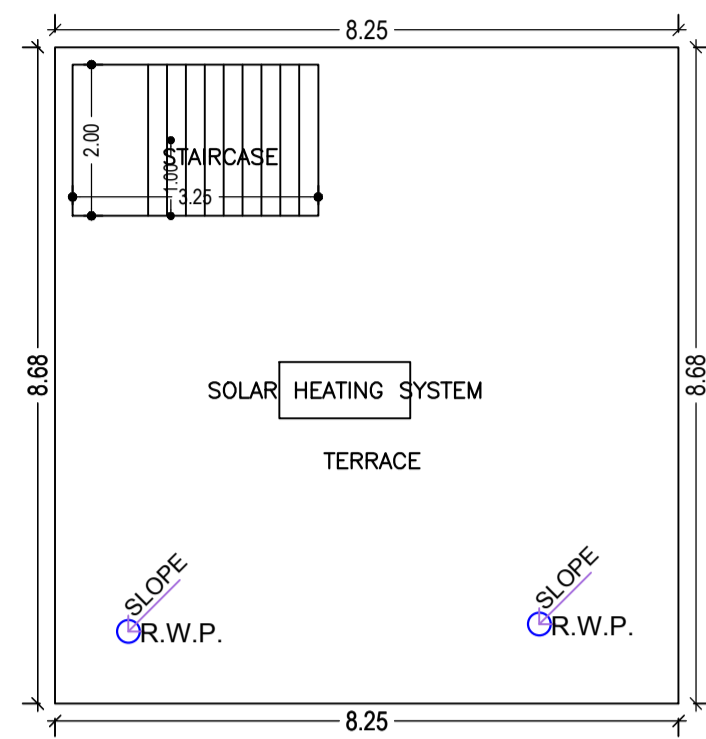

TERRACE FLOOR PLAN  
(SCALE 1:100)

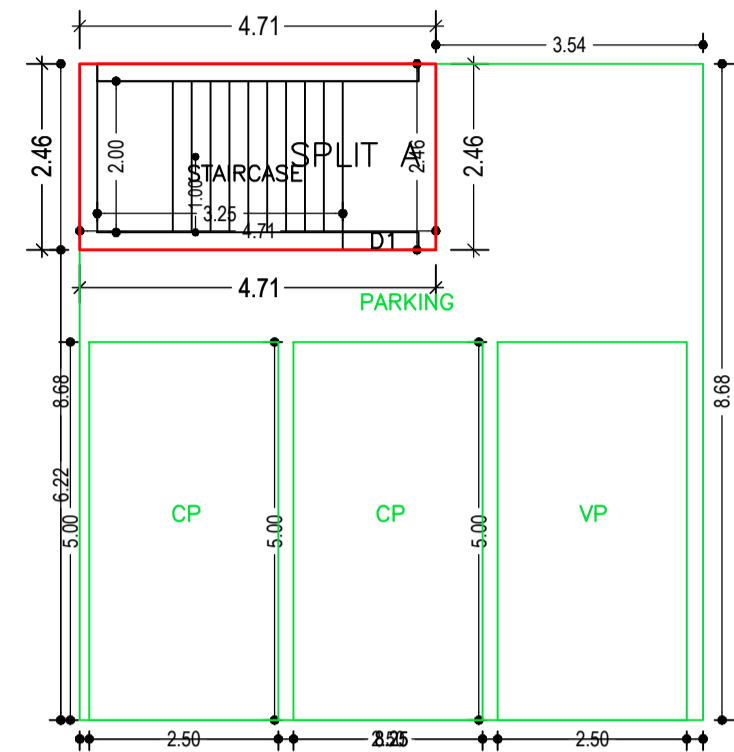

GROUND FLOOR PLAN  
(Proposed)  
(SCALE 1:100)

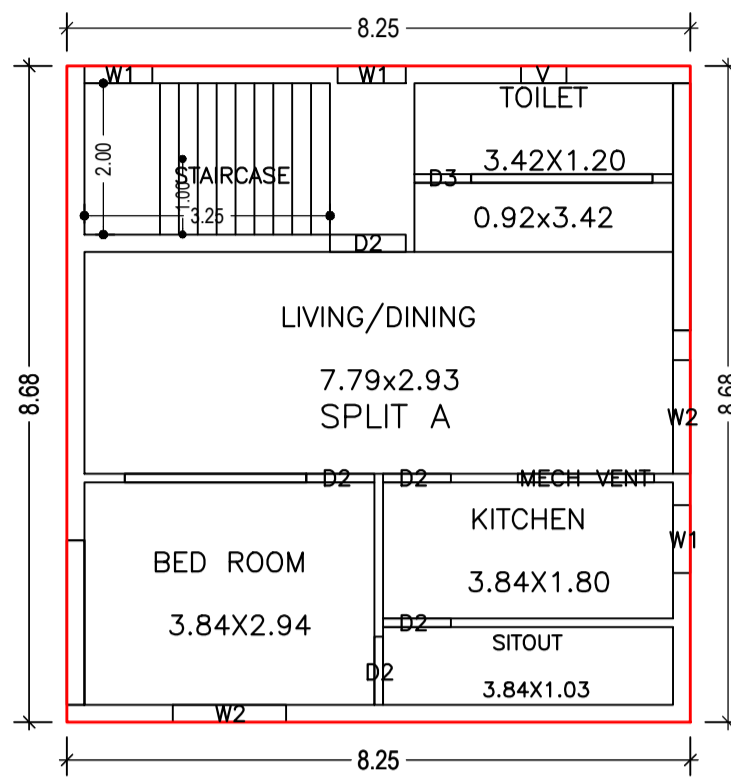

FIRST FLOOR PLAN  
(Proposed)  
(SCALE 1:100)

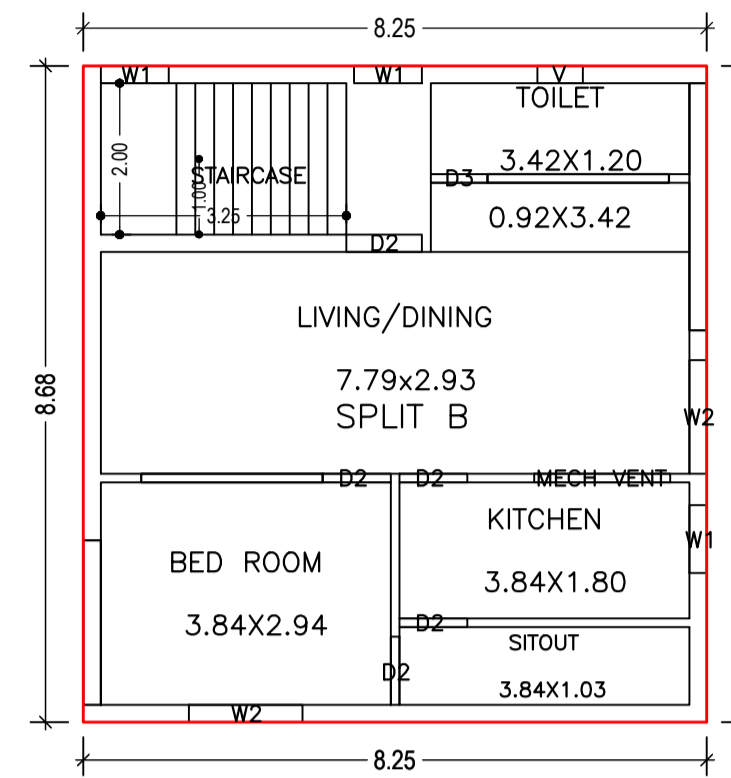

SECOND FLOOR PLAN  
(Proposed)  
(SCALE 1:100)

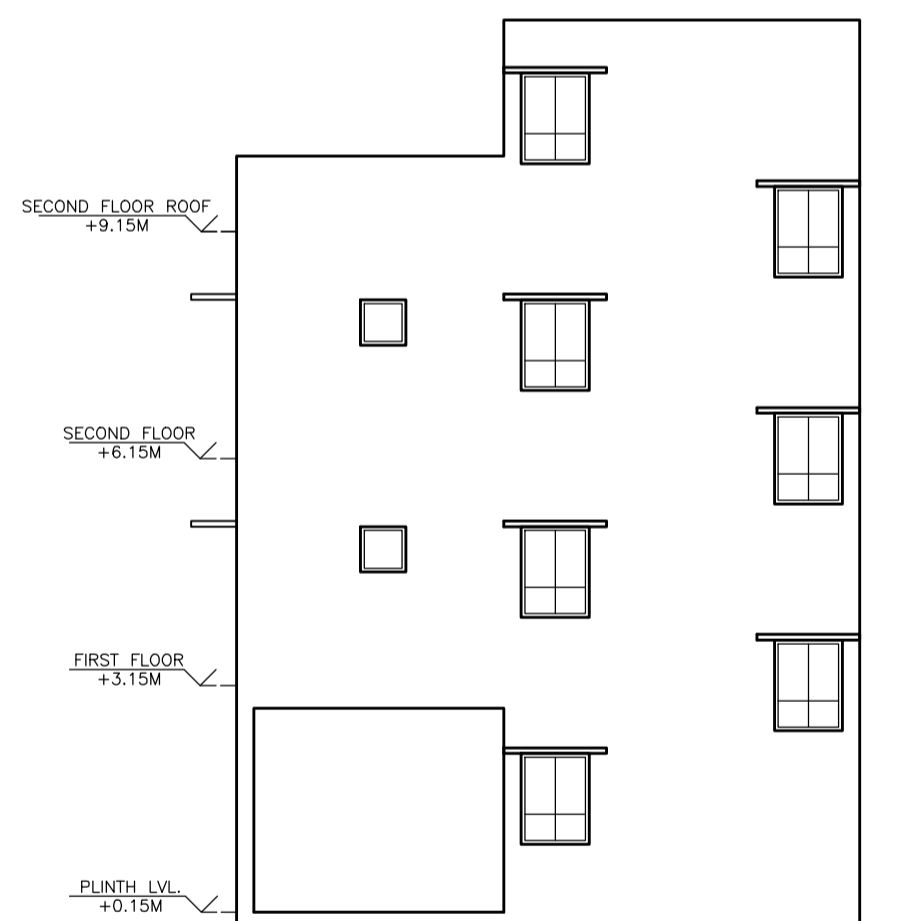
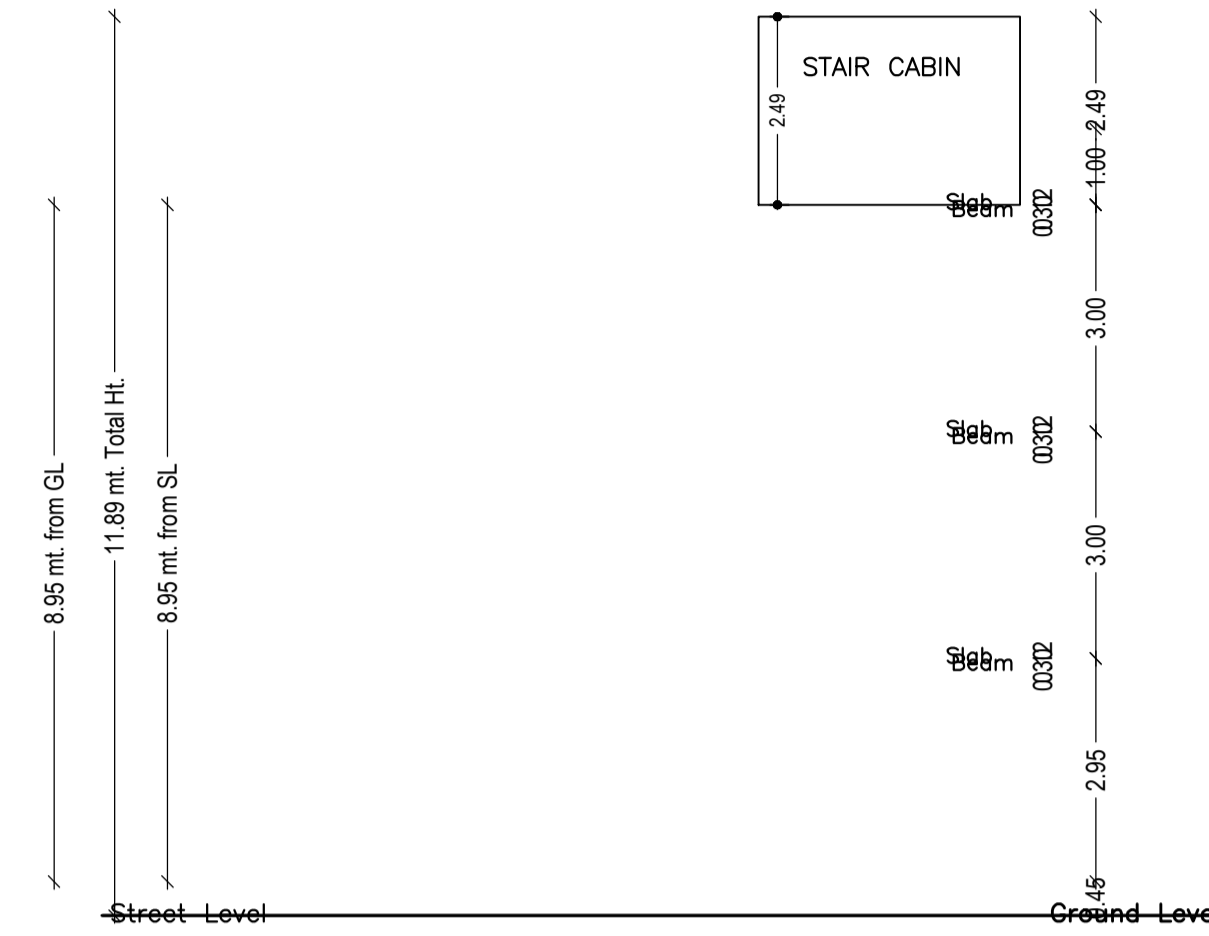

REAR ELEVATION  
SCALE- 1:75

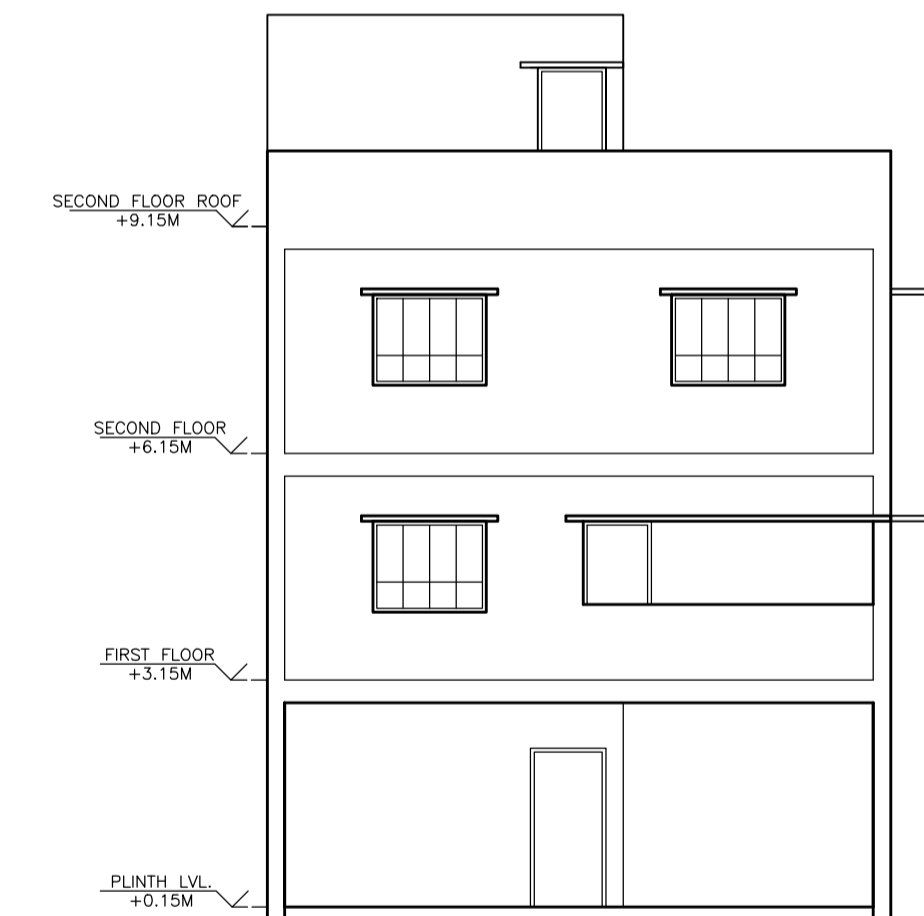
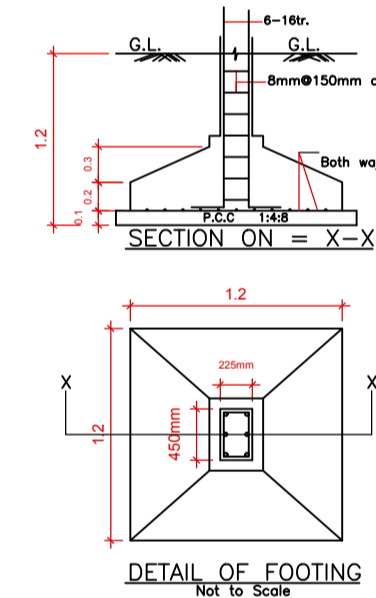
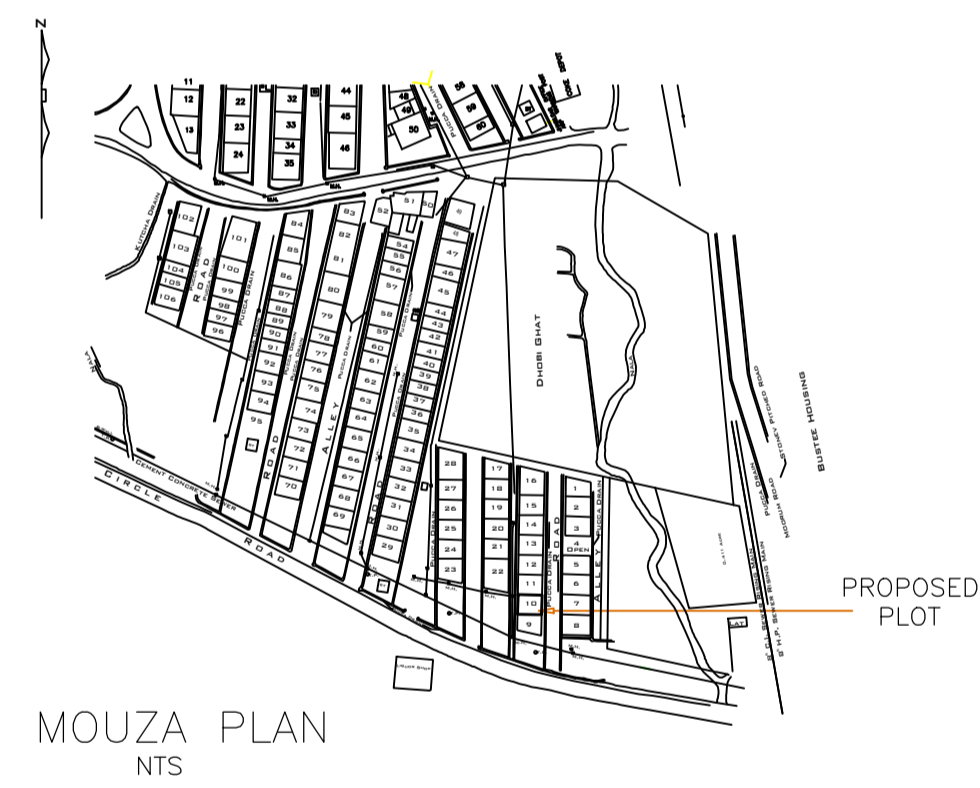

FRONT ELEVATION  
SCALE- 1:75

LTP NAME AND SIGNATURE	STRUCTURAL ENG'S NAME AND SIGNATURE	BUILDER NAME AND SIGNATURE	DIGITAL SIGNATURE
Amarjeet Balmuchu JNAC/ARC/0008/2018			