

SITE PLAN
(Scale - 1:400)

FAR & Tenement Details (Table 4c-1)

Building	No. of Same Bldg	Total Built Up Area (Sq.mt.)	Deductions (Area in Sq.mt.) Parking	Proposed FAR Area (Sq.mt.) Resi.	Add Area In FAR (Sq.mt.) Stair	Total FAR Area (Sq.mt.)	Total Consumed Additional FAR Area (Sq.mt.)	Tnmt (No.)
A (RAVI SHANKAR PRASAD)	1	269.58	74.11	179.72	15.75	195.47	195.47	01
Grand Total :	1	269.58	74.11	179.72	15.75	195.47	195.47	01

Proposal Basic Information

Proposal File No.	JNAC/BP/0066/W7/2021
Owner Name	RAVI SHANKAR PRASAD
Khata No	245
Plot No	104
Village Name	SAKCHI
Use	Residential
SubUse	Row House

AREA STATEMENT JAMSHEDPUR NAC	VERSION NO. : 1.0.60 VERSION DATE: 16/10/2020
PROJECT DETAIL:	
Region: JHARKHAND URBAN LOCAL BODIES	Plot Use: Residential
District: EAST SINGHBHUM	Plot SubUse: Row House
Authority: JAMSHEDPUR NAC	PlotNearby/ReligiousStructure: NA
Inward_No: JNAC/BP/0066/W7/2021	PlotSubPlotNo: 104
Application Type: General Proposal	North: Plot No. - 105
Project Type: Building Permission	South: Plot No. - 103
Nature of Development: New	East: Road Width - 7.2 M
Location of Development Area: Old Area	West: Road Width - 6.0 M
AREA DETAILS:	
AREA OF PLOT (Minimum)	(A) 148.11
NET AREA OF PLOT(Gross Plot Area - Deduction from Gross Plot area)	(A-Deductions) 148.11
Deduction for Balance Plot Area(from Gross Plot Area)	
Common Plot	25.62
Total	25.62
BALANCE AREA OF PLOT(Net Plot Area - Recreational/Amenity space)	(A-Deductions) 122.49
PLOT AREA FOR COVERAGE(Net Plot Area)	(A-Deductions) 148.11
Plot Area for FAR (Net Plot Area + RoadWidening Area)	(A-Deductions) 148.11
COVERAGE CHECK	
Permissible Coverage area (70.00 %)	103.68
Proposed Coverage Area (60.67 %)	89.86
Total Prop. Coverage Area (60.67 %)	89.86
Balance coverage area (9.33 %)	13.82
FAR CHECK	
Perm. FAR Area (1.50)	222.17
Total Perm. FAR area	222.17
Residential FAR	179.73
Proposed FAR Area	195.48
Total Proposed FAR Area	195.48
Consumed FAR (Factor)	1.32
Balance FAR Area	26.69
BUILT UP AREA CHECK	
Total Proposed BuiltUp Area	269.58
ARCHITECT (Regd)	Ajit Kumar Dhar
ENGINEER (Regd)	
SUPERVISOR (Regd)	
OWNER (Regd)	RAVI SHANKAR PRASAD
DEVELOPMENT AUTHORITY	LOCAL BODY

COLOR INDEX	
PLOT BOUNDARY	Black
ABUTTING ROAD	Green
PROPOSED CONSTRUCTION	Red
COMMON PLOT	Yellow
ROAD WIDENING AREA	Orange
EXISTING (To be retained)	Blue
EXISTING (To be demolished)	Light Blue

Buildingwise Floor FAR Details

Floor Name	Building Name A (RAVI SHANKAR PRASAD)		Total	
	Proposed Built Up Area (Sq.mt.)	Proposed FAR Area (Sq.mt.)	Total Proposed Built Up Area (Sq.mt.)	Total FAR Area (Sq.mt.)
Parking Floor	89.86	15.75	89.86	15.75
First Floor	89.86	89.86	89.86	89.86
Second Floor	89.86	89.86	89.86	89.86
Terrace Floor	0.00	0.00	0.00	0.00
Total :	269.58	195.47	269.58	195.47

Building USE/SUBUSE Details

Building Name	Building Use	Building SubUse	Building Structure
A (RAVI SHANKAR PRASAD)	Residential	Row House	Non-Highrise

LTP NAME AND SIGNATURE	STRUCTURAL ENG'S NAME AND SIGNATURE	BUILDER NAME AND SIGNATURE	DIGITAL SIGNATURE
Ajit Kumar Dhar JNAC/DFTMN/0009/2017			

Proposal Basic Information	
Proposal File No.	JNAC/BP/0066/W7/2021
Owner Name	RAVI SHANKAR PRASAD
Khata No	245
Plot No	104
Village Name	SAKCHI
Use	Residential
SubUse	Row House

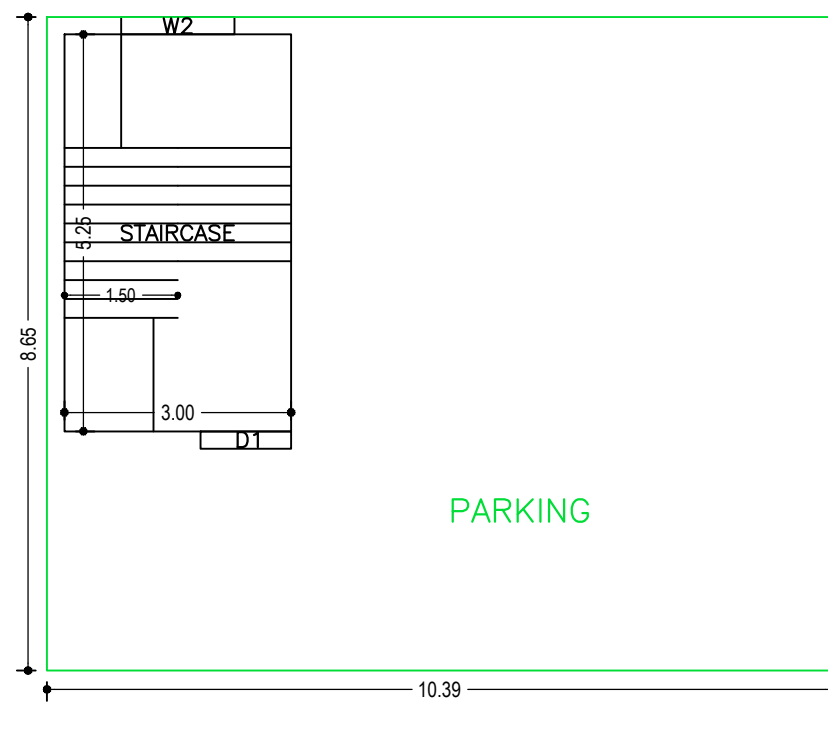

PARKING FLOOR PLAN (SCALE 1:100)

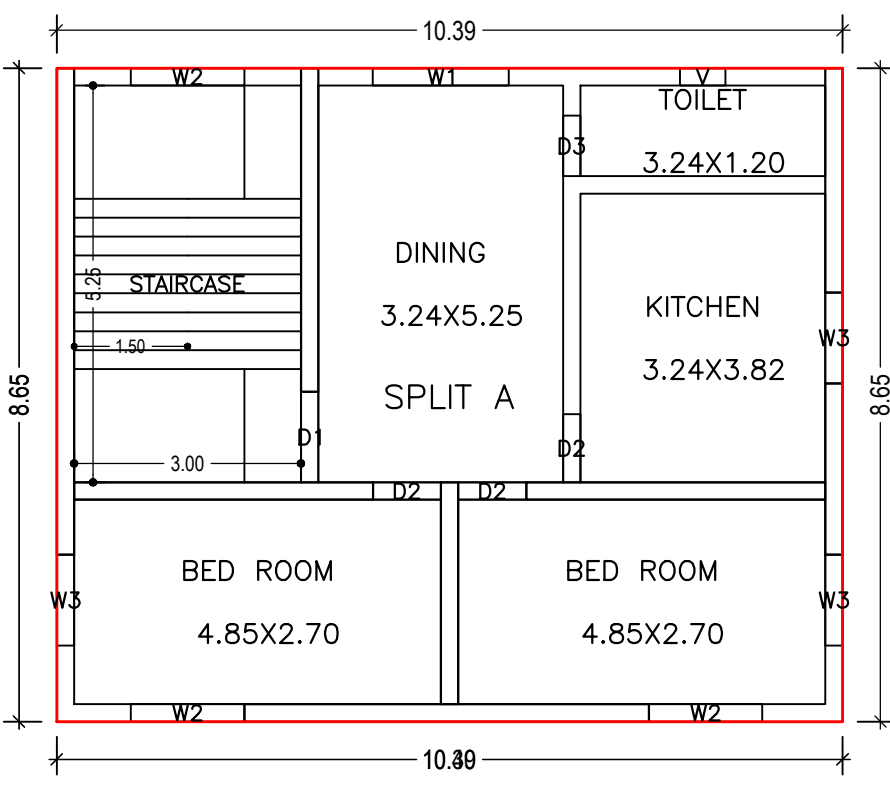

SECOND FLOOR PLAN (Proposed) (SCALE 1:100)

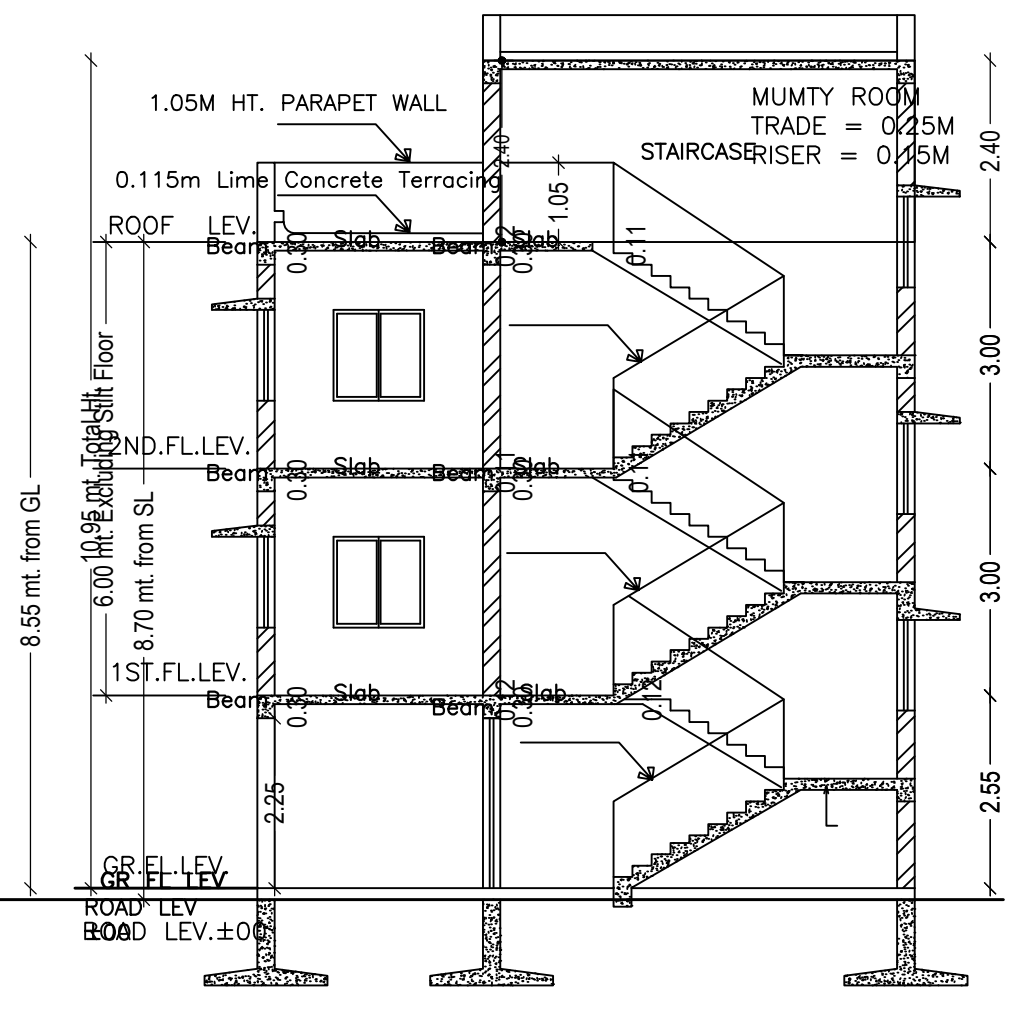

SECTION - A-A (SCALE 1:100)

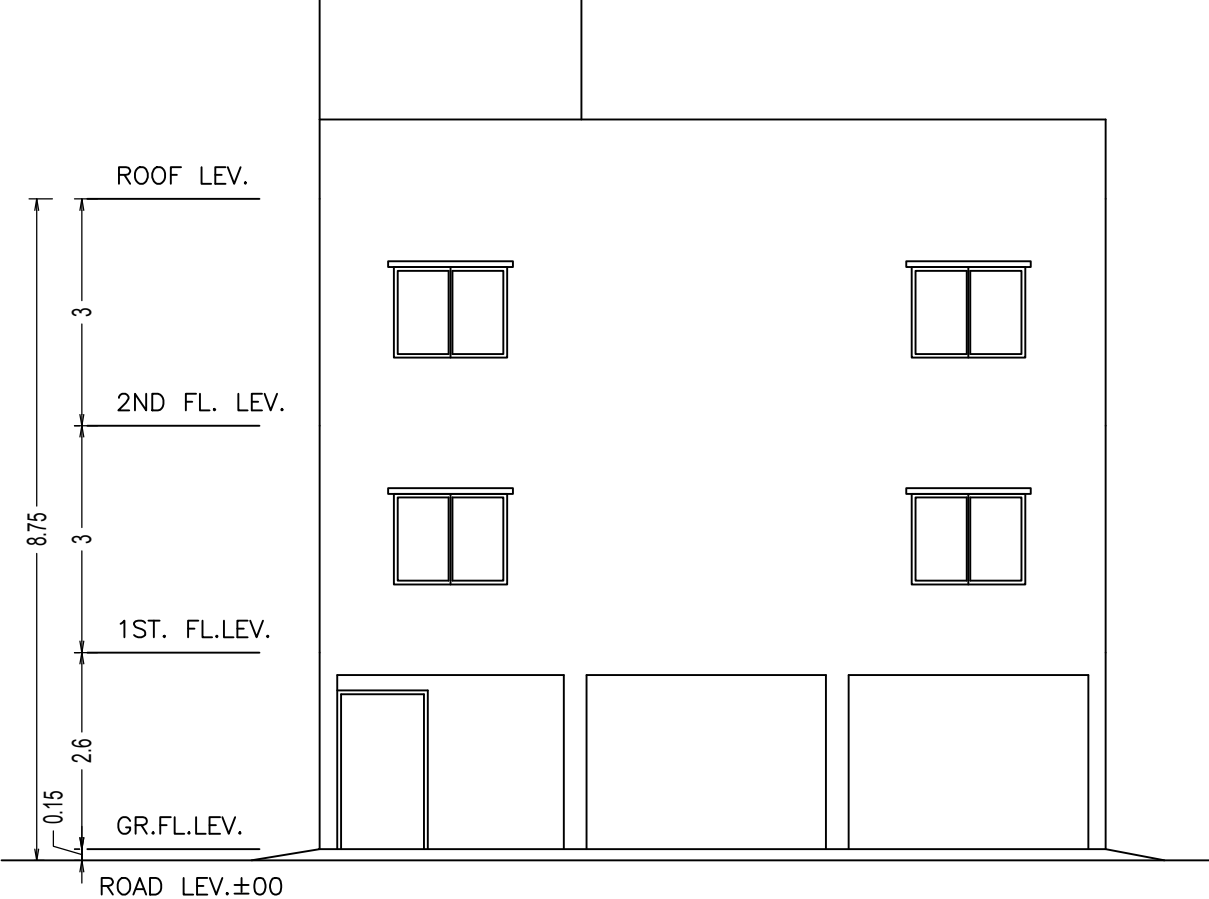

FRONT ELEVATION (SCALE 1:100)

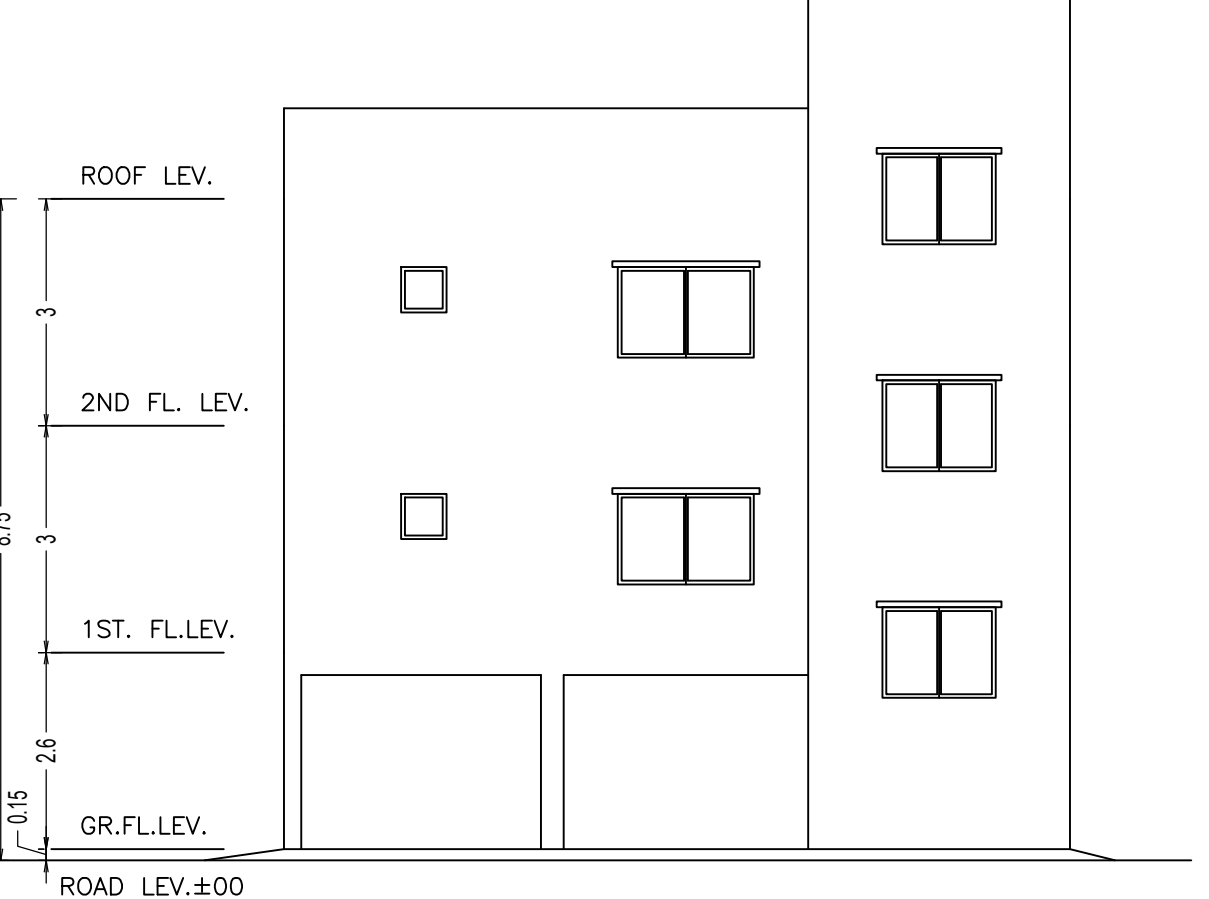

REAR ELEVATION (SCALE 1:100)

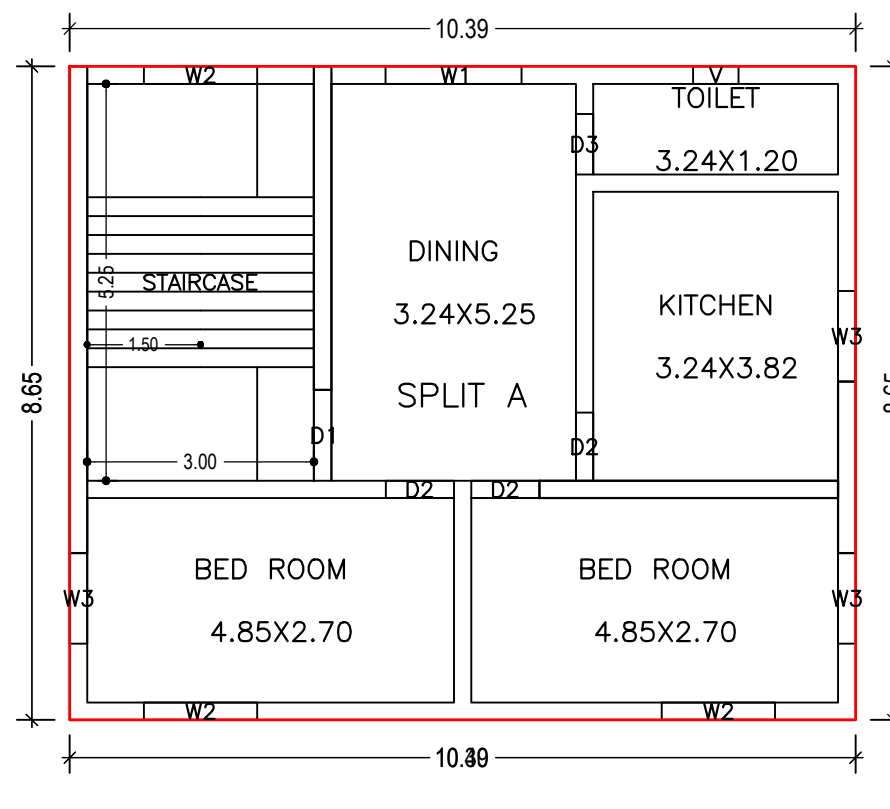

FIRST FLOOR PLAN (Proposed) (SCALE 1:100)

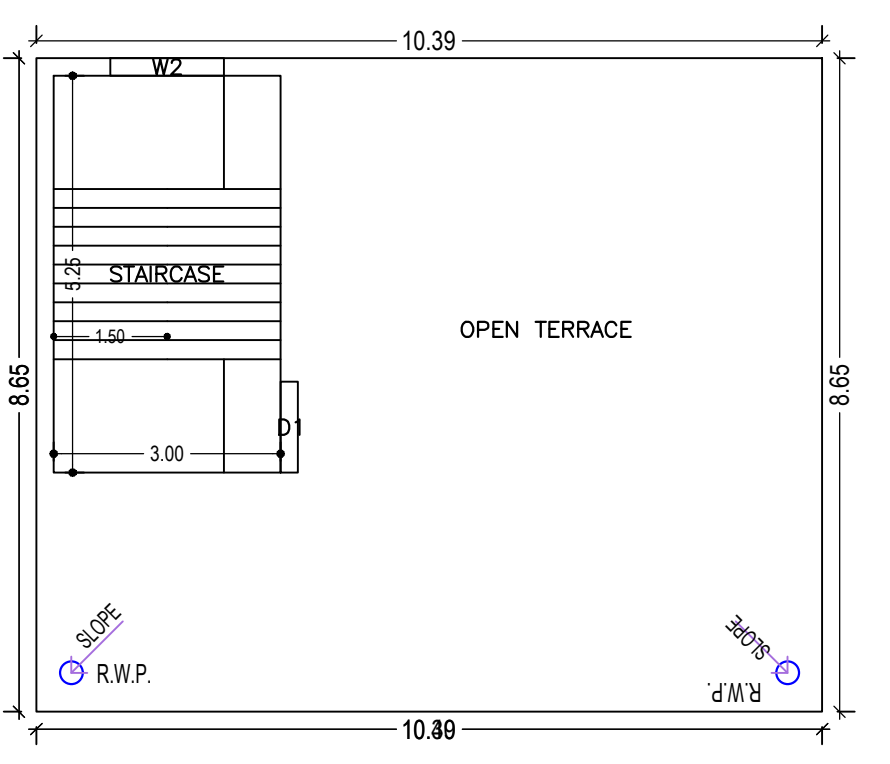

TERRACE FLOOR PLAN (SCALE 1:100)

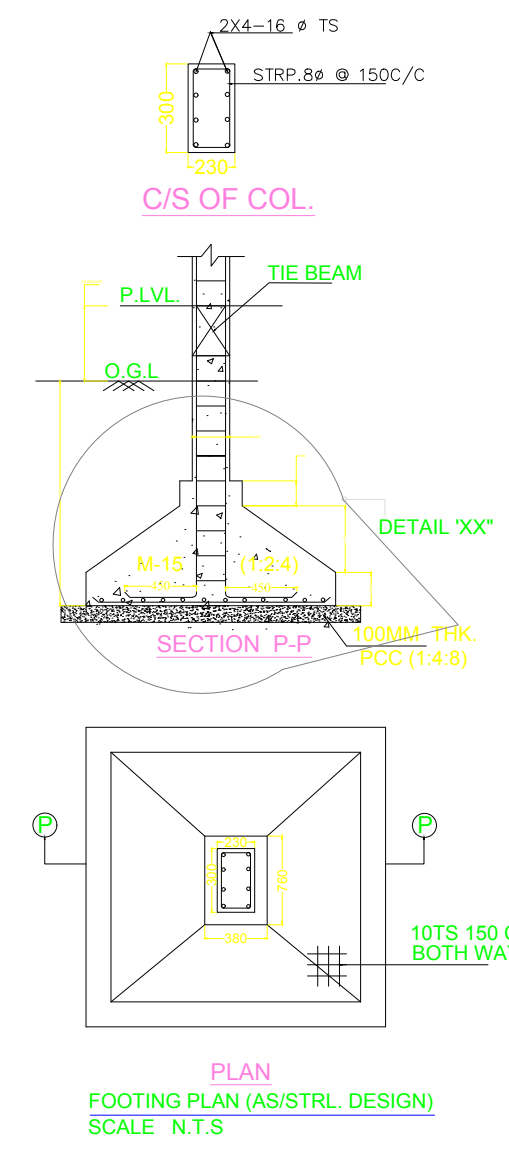

PLAN FOOTING PLAN (AS/STR.L. DESIGN) (SCALE N.T.S.)

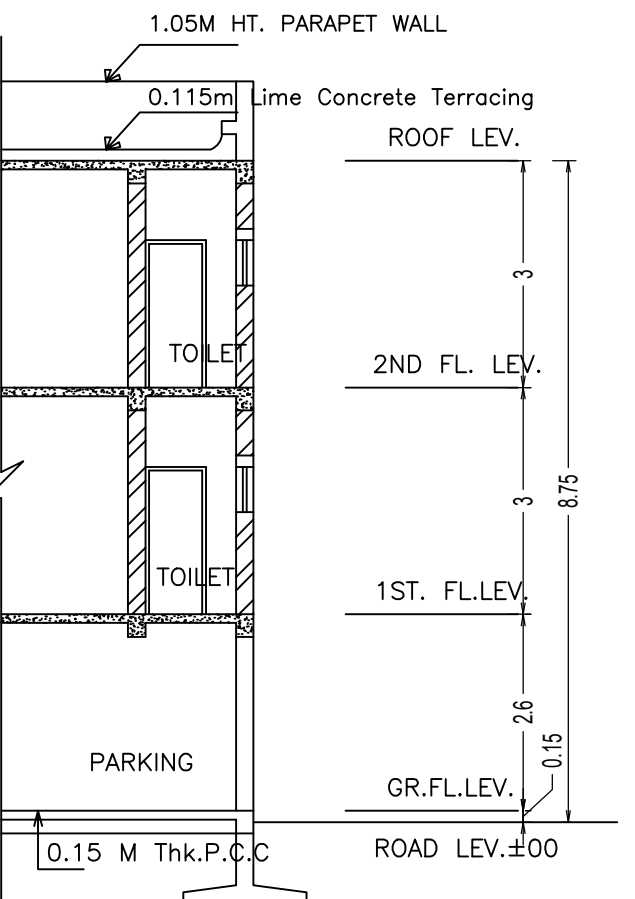

SECTION - B - B (SCALE 1:100)

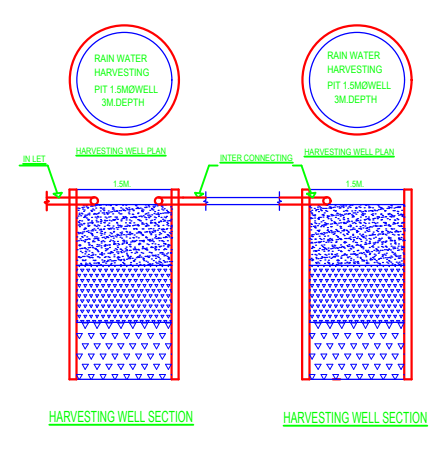

Building :A (RAVI SHANKAR PRASAD)

Floor Name	Total Built Up Area (Sq.mt.)	Deductions (Area in Sq.mt.)	Proposed FAR Area (Sq.mt.)			Total FAR Area (Sq.mt.)	Total Consumed Additional FAR Area (Sq.mt.)	Trmt (No.)
			Parking	Resi.	Stair			
Parking Floor	89.86	74.11	0.00	15.75	15.75	15.75	00	
First Floor	89.86	0.00	89.86	0.00	89.86	89.86	01	
Second Floor	89.86	0.00	89.86	0.00	89.86	89.86	00	
Terrace Floor	0.00	0.00	0.00	0.00	0.00	0.00	00	
Total :	269.58	74.11	179.72	15.75	195.47	195.47	01	
Total Number of Same Buildings	1							
Total :	269.58	74.11	179.72	15.75	195.47	195.47	01	

SCHEDULE OF DOOR:

BUILDING NAME	NAME	LENGTH	HEIGHT	NOS
A (RAVI SHANKAR PRASAD)	D3	0.80	2.10	02
A (RAVI SHANKAR PRASAD)	D2	0.90	2.10	06
A (RAVI SHANKAR PRASAD)	D1	1.20	2.10	02

SCHEDULE OF WINDOW/VENTILATION:

BUILDING NAME	NAME	LENGTH	HEIGHT	NOS
A (RAVI SHANKAR PRASAD)	V	0.60	0.60	02
A (RAVI SHANKAR PRASAD)	W3	1.20	1.20	06
A (RAVI SHANKAR PRASAD)	W2	1.50	1.20	08
A (RAVI SHANKAR PRASAD)	W1	1.80	1.20	02

UnitBUA Table for Building :A (RAVI SHANKAR PRASAD)

FLOOR	Name	UnitBUA Type	UnitBUA Area	Carpet Area	No. of Rooms	No. of Tenement
FIRST FLOOR	SPLIT A	FLAT	179.73	168.44	5	1
SECOND FLOOR	SPLIT A	FLAT	0.00	0.00	5	0
Total:	-	-	179.73	168.44	10	1

LTP NAME AND SIGNATURE	STRUCTURAL ENG'S NAME AND SIGNATURE	BUILDER NAME AND SIGNATURE	DIGITAL SIGNATURE
Ajit Kumar Dhar JNAC/DFTMN/0009/2017			

Proposal Basic Information	
Proposal File No.	JNAC/BP/0066/W7/2021
Owner Name	RAVI SHANKAR PRASAD
Khata No	245
Plot No	104
Village Name	SAKCHI
Use	Residential
SubUse	Row House

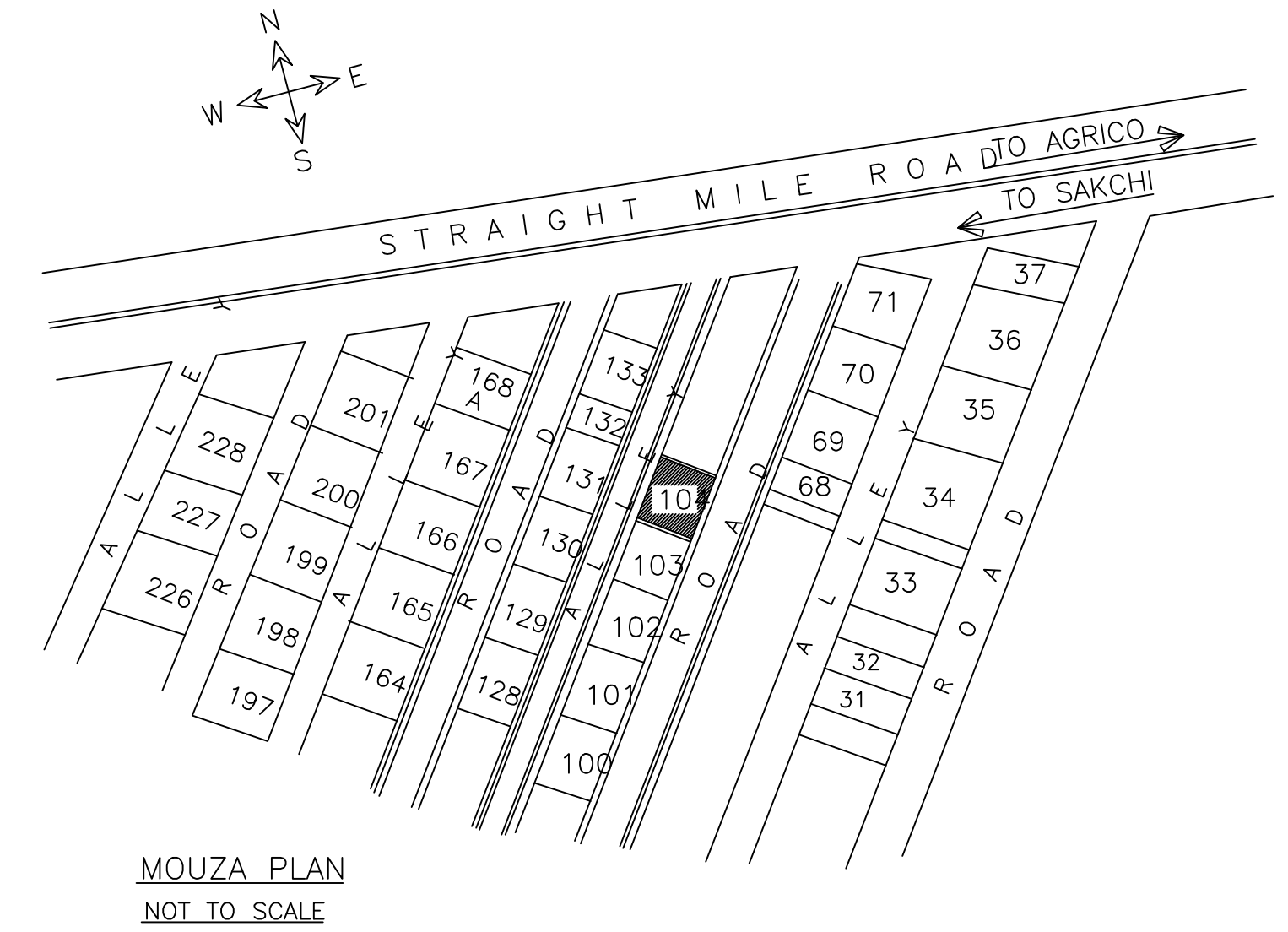

LTP NAME AND SIGNATURE	STRUCTURAL ENG'S NAME AND SIGNATURE	BUILDER NAME AND SIGNATURE	DIGITAL SIGNATURE
Ajit Kumar Dhar JNAC/DFTMN/0009/2017			