

FAR & Tenement Details (Table 4c-1)

Building	No. of Same Bldg	Total Built Up Area (Sq.mt.)	Deductions (Area in Sq.mt.)		Proposed FAR Area (Sq.mt.)	Total FAR Area (Sq.mt.)	Total Consumed Additional FAR Area (Sq.mt.)	Trmnt (No.)
			Parking	Resi.				
PROPOSED (BUILDING)	1	214.48	59.91	-	154.57	154.57	154.57	02
Grand Total :	1	214.48	59.91	-	154.57	154.57	154.57	02

Proposal Basic Information

Proposal File No.	JNAC/BP/0042/W11/2021
Owner Name	sambhu nath biswas sabita joarder shyama shree biswas swadesh kumar biswas
Khata No	52
Plot No	1005
Village Name	Sitaramdera
Use	Residential
SubUse	Bungalow/ Dwelling / Non Apartment

Required Parking (Table 7a)

Building Name	Type	SubUse	Area (Sq.mt.)	Units		Car		Visitors Car			
				Reqd.	Prop.	Reqd./Unit	Reqd.	Prop.	Reqd./Unit	Reqd.	Prop.
PROPOSED (BUILDING)	Residential	Bungalow/ Dwelling / Non Apartment	>0	1	2.00	1.00	2	-	-	-	
				1	2.00	-	-	1	1	-	
Total :				-	-	-	2	2	-	1	1

Parking Check (Table 7b)

Vehicle Type	Reqd.		Prop.	
	No.	Area	No.	Area
Car	-	-	2	25.00
Total Car	2	25.00	2	25.00
Visitor's Car Parking	-	-	1	12.50
Total Visitor Parking	1	12.50	1	12.50
Other Parking	-	-	-	22.41
Total		37.50		59.91

AREA STATEMENT JAMSHEDPUR NAC	VERSION NO.: 1.0.57	
PROJECT DETAIL:	VERSION DATE: 16/10/2020	
Region: JHARKHAND URBAN LOCAL BODIES	Plot Use: Residential	
District: EAST SINGHBHUM	Plot SubUse: Bungalow/ Dwelling / Non Apartment	
Authority: JAMSHEDPUR NAC	Plot/Nearby/Religious Structure: NA	
Inward_No.: JNAC/BP/0042/W11/2021	Plot/SubPlot No: 1005	
Application Type: General Proposal	North: Road Width - 9.0	
Project Type: Building Permission	South: Plot No. - Alley	
Nature of Development: New	East: Plot No. - 330	
Location of Development Area: Old Area	West: Plot No. - 338	
AREA DETAILS:		SQ.MT.
AREA OF PLOT (Minimum)	(A)	111.40
NET AREA OF PLOT (Gross Plot Area - Deduction from Gross Plot area)	(A-Deductions)	111.40
Deduction for Balance Plot Area (from Gross Plot Area)		
Common Plot		8.00
Total		8.00
BALANCE AREA OF PLOT (Net Plot Area - Recreational/Amenity space)	(A-Deductions)	103.40
PLOT AREA FOR COVERAGE (Net Plot Area)	(A-Deductions)	111.40
Plot Area for FAR (Net Plot Area + Road Widening Area)	(A-Deductions)	111.40
COVERAGE CHECK		
Permissible Coverage area (70.00 %)		77.98
Proposed Coverage Area (64.18 %)		71.49
Total Prop. Coverage Area (64.18 %)		71.49
Balance coverage area (5.83 %)		6.49
FAR CHECK		
Perm. FAR Area (2.50)		278.50
Total Perm. FAR area		278.50
Residential FAR		154.57
Proposed FAR Area		154.57
Total Proposed FAR Area		154.57
Consumed FAR (Factor)		1.39
Balance FAR Area		123.93
BUILT UP AREA CHECK		
Total Proposed BuiltUp Area		214.48
ARCHITECT (Regd)	Amarjeet Balmuchu	
ENGINEER (Regd)		
SUPERVISOR (Regd)		
OWNER (Regd)	sambhu nath biswas sabita joarder shyama shree biswas swadesh kumar biswas	
DEVELOPMENT AUTHORITY	LOCAL BODY	

COLOR INDEX	
PLOT BOUNDARY	[Red Line]
ABUTTING ROAD	[Green Line]
PROPOSED CONSTRUCTION	[Blue Line]
COMMON PLOT	[Yellow Line]
ROAD WIDENING AREA	[Orange Line]
EXISTING (To be retained)	[Purple Line]
EXISTING (To be demolished)	[Light Blue Line]

Buildingwise Floor FAR Details

Floor Name	Building Name		Total	
	PROPOSED (BUILDING) Proposed Built Up Area (Sq.mt.)	PROPOSED FAR Area (Sq.mt.)	Total Proposed Built Up Area (Sq.mt.)	Total FAR Area (Sq.mt.)
Ground Floor	71.50	11.59	71.50	11.59
First Floor	71.49	71.49	71.49	71.49
Second Floor	71.49	71.49	71.49	71.49
Terrace Floor	0.00	0.00	0.00	0.00
Total :	214.48	154.57	214.48	154.57

Building USE/SUBUSE Details

Building Name	Building Use	Building SubUse	Building Structure
PROPOSED (BUILDING)	Residential	Bungalow/ Dwelling / Non Apartment	Non-Highrise

LTP NAME AND SIGNATURE	STRUCTURAL ENG'S NAME AND SIGNATURE	BUILDER NAME AND SIGNATURE	DIGITAL SIGNATURE
Amarjeet Balmuchu JNAC/ARC/0008/2018			

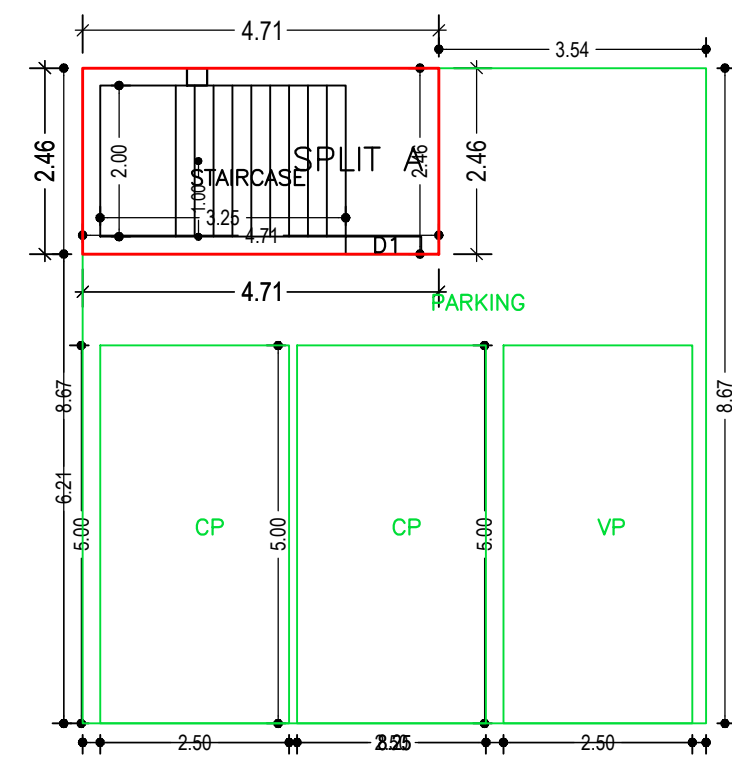

GROUND FLOOR PLAN (Proposed) (SCALE 1:100)

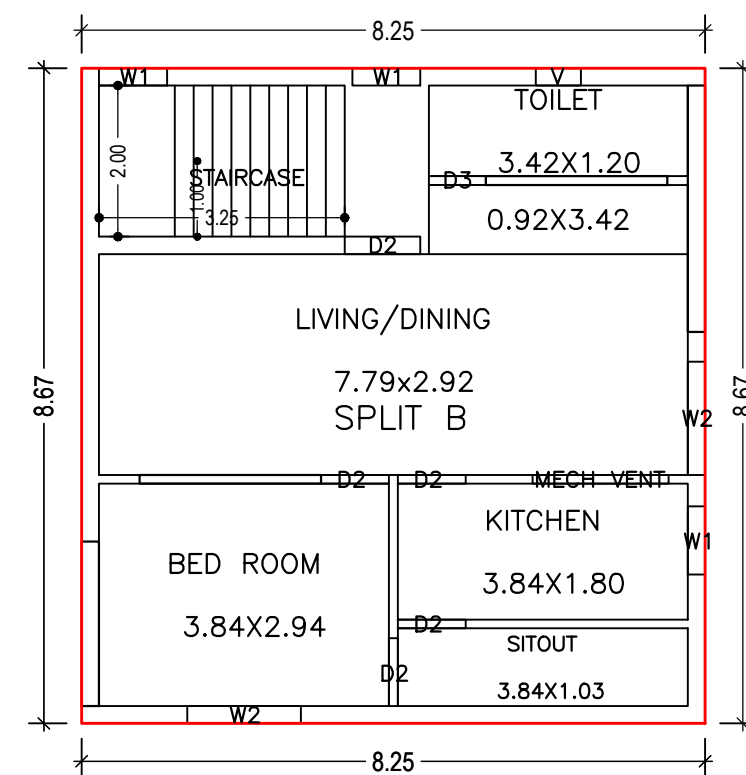

SECOND FLOOR PLAN (Proposed) (SCALE 1:100)

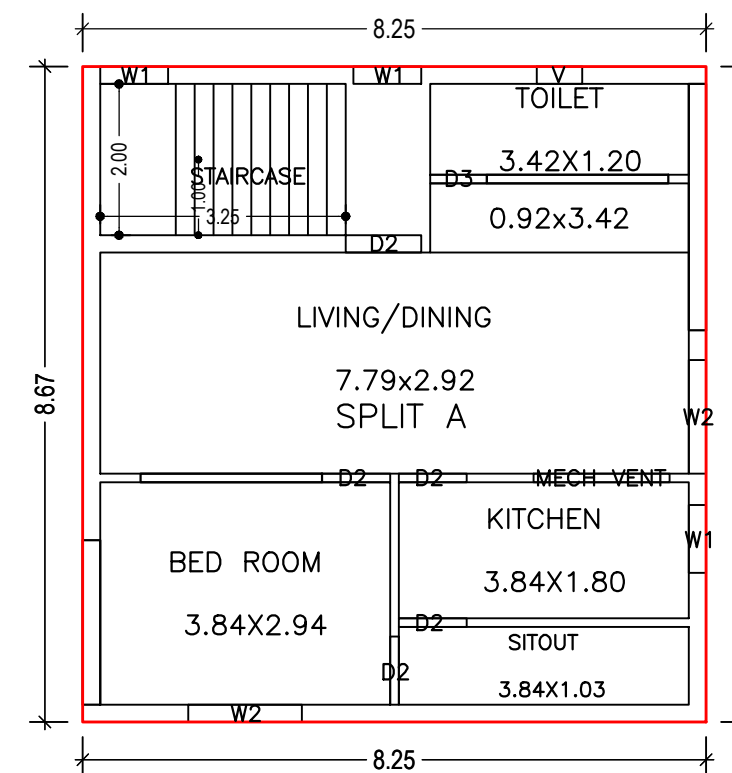

FIRST FLOOR PLAN (Proposed) (SCALE 1:100)

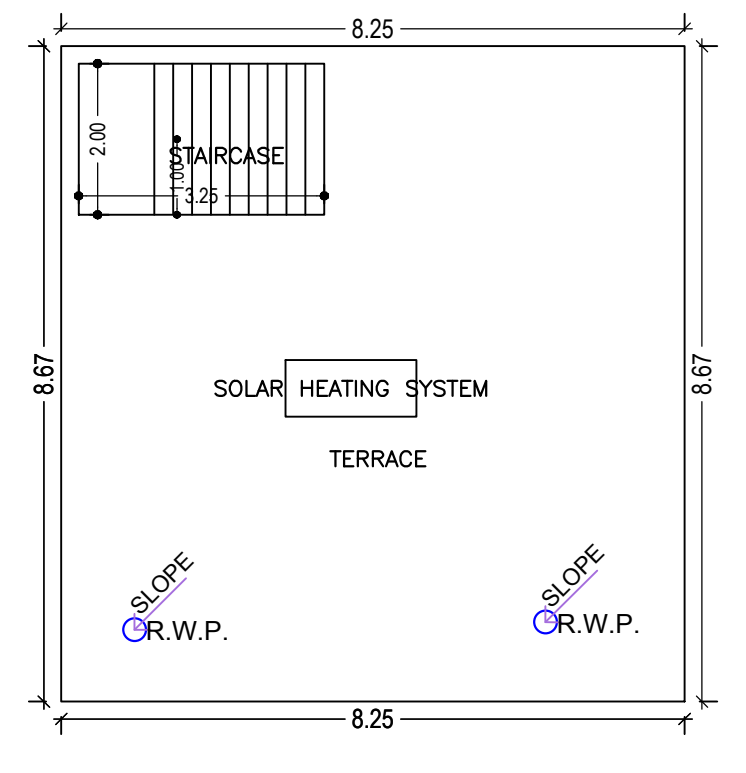

TERRACE FLOOR PLAN (SCALE 1:100)

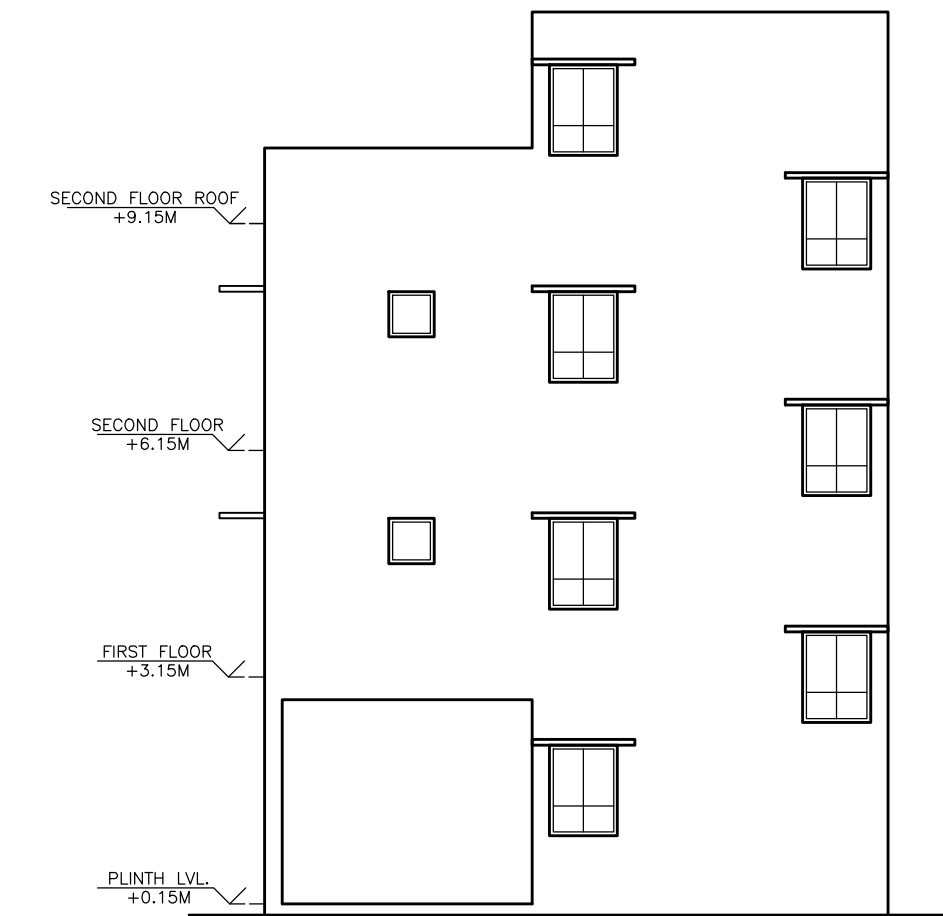
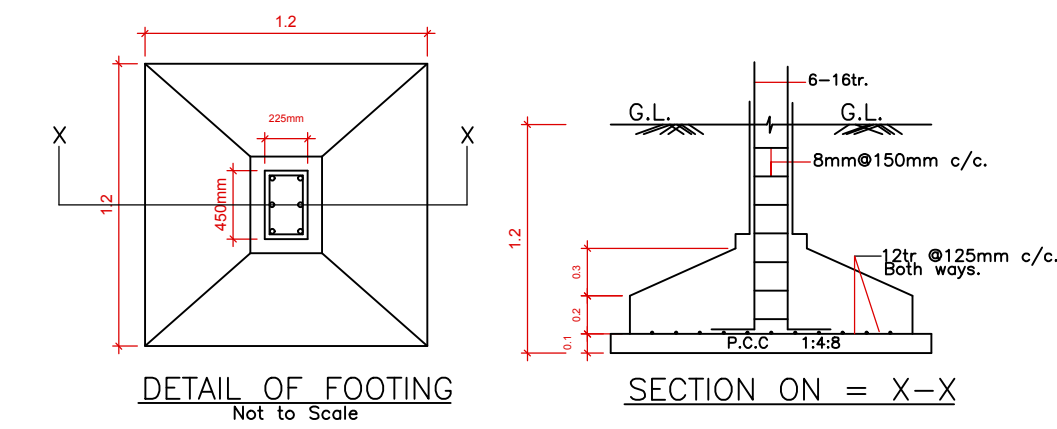
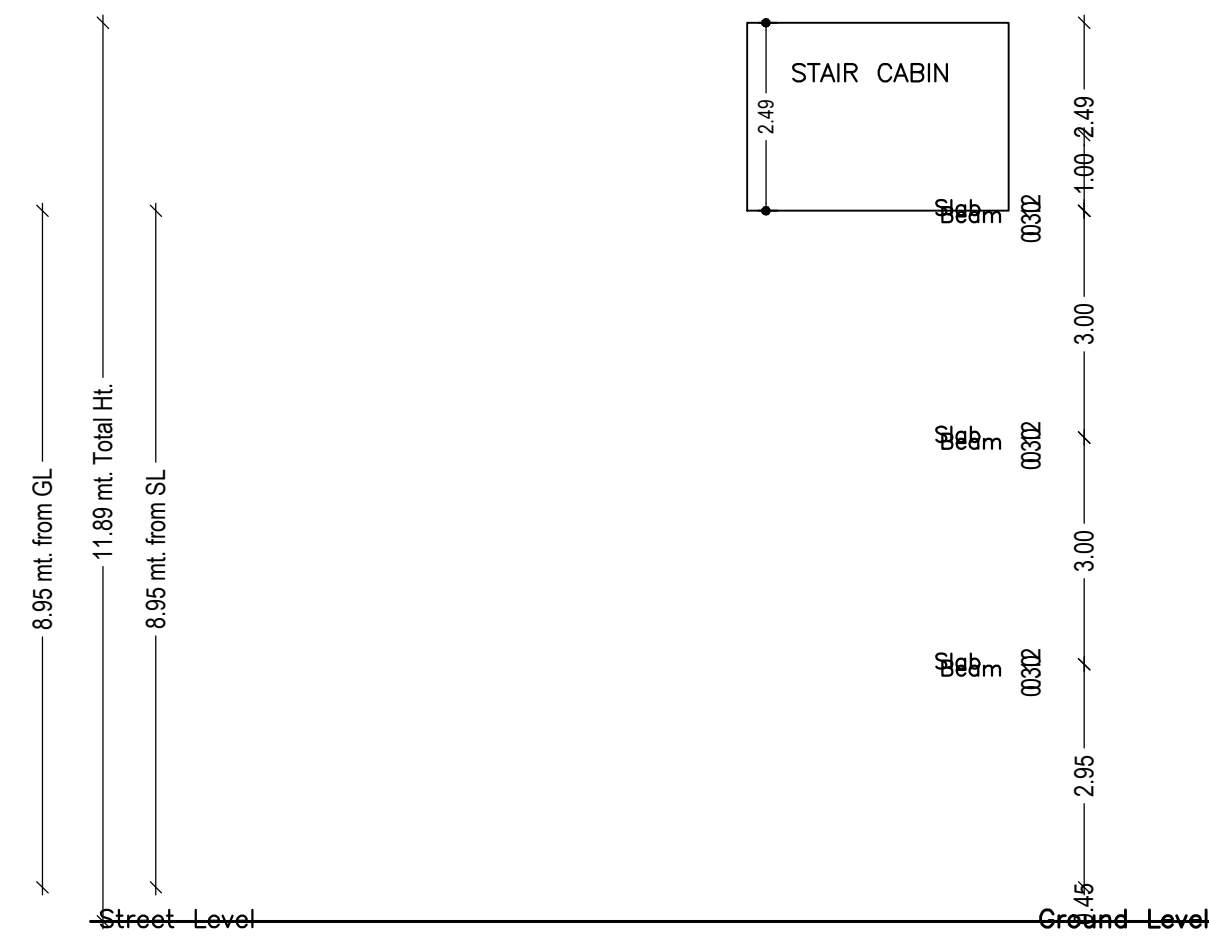

REAR ELEVATION SCALE- 1:75

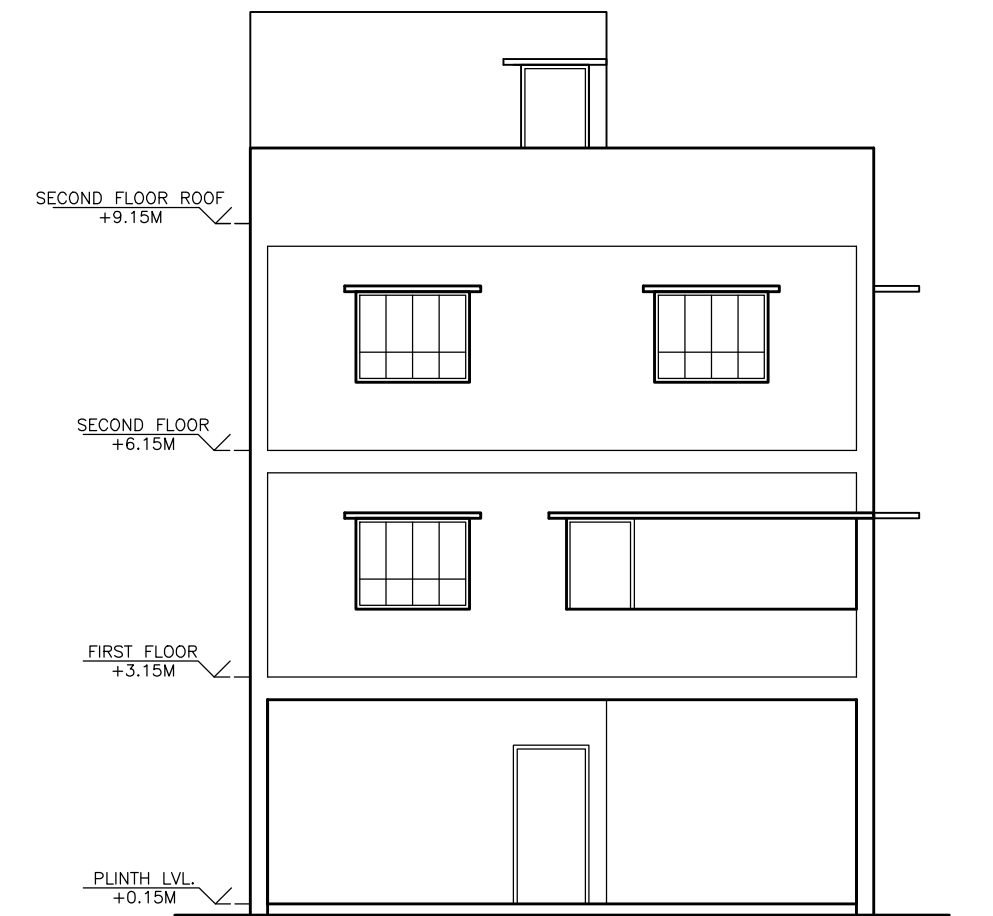

FRONT ELEVATION SCALE- 1:75

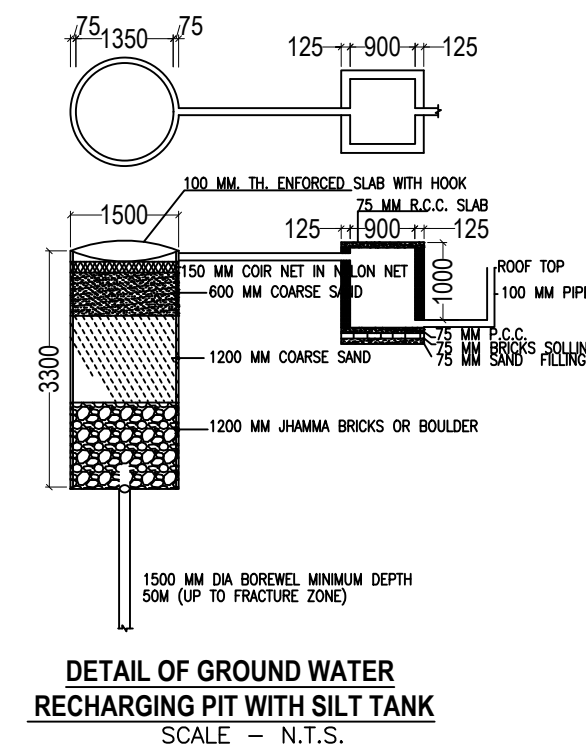

DETAIL OF GROUND WATER RECHARGING PIT WITH SILT TANK SCALE - N.T.S.

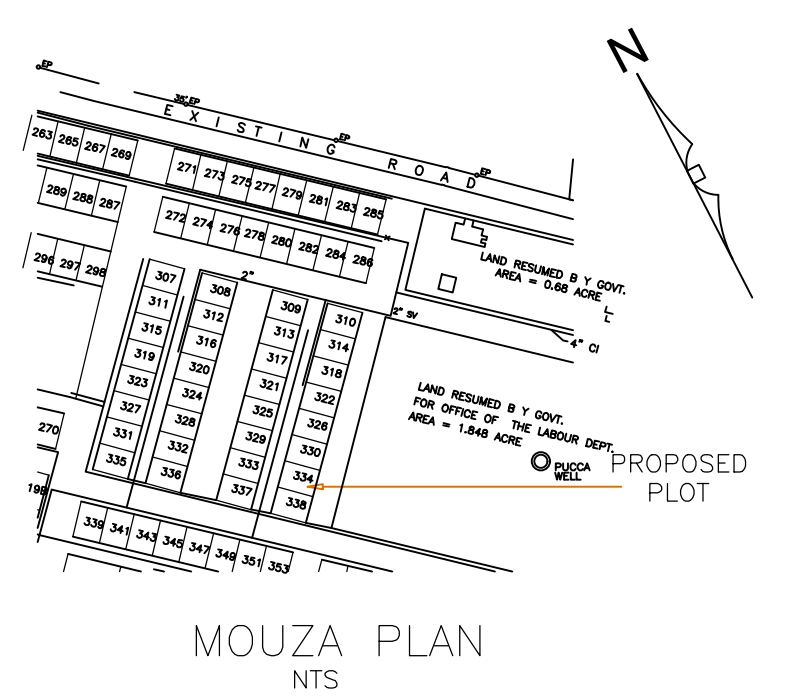

MOUZA PLAN N.T.S.

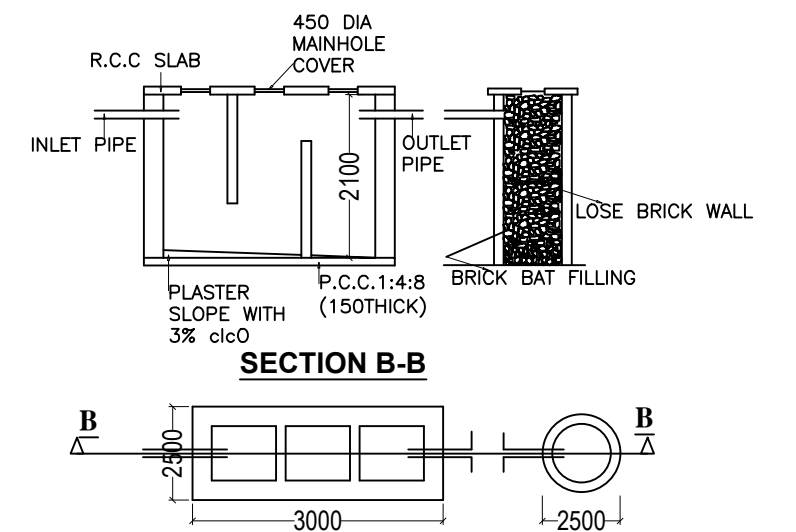

DETAIL OF SEPTIC TANK & SOAKPIT. SCALE - 1:50

SCHEDULE OF DOOR:

BUILDING NAME	NAME	LENGTH	HEIGHT	NOS
PROPOSED (BUILDING)	D3	0.75	2.10	02
PROPOSED (BUILDING)	D2	0.90	2.10	08
PROPOSED (BUILDING)	D2	1.00	2.10	02

SCHEDULE OF WINDOW/VENTILATION:

BUILDING NAME	NAME	LENGTH	HEIGHT	NOS
PROPOSED (BUILDING)	V	0.60	1.20	02
PROPOSED (BUILDING)	W1	0.90	1.20	04
PROPOSED (BUILDING)	W2	1.50	1.20	04
PROPOSED (BUILDING)	MECH VENT	1.80	1.20	02

UnitBUA Table for Building :PROPOSED (BUILDING)

FLOOR	Name	UnitBUA Type	UnitBUA Area	Carpet Area	No. of Rooms	No. of Tenement
GROUND FLOOR PLAN	SPLIT A	FLAT	74.94	74.33	0	1
FIRST FLOOR PLAN	SPLIT A	FLAT	0.00	0.00	5	0
SECOND FLOOR PLAN	SPLIT B	FLAT	63.92	63.37	5	1
Total:	-	-	138.86	137.70	10	2

Building :PROPOSED (BUILDING)

Floor Name	Total Built Up Area (Sq.mt.)	Deductions (Area in Sq.mt.)	Proposed FAR Area (Sq.mt.)	Total FAR Area (Sq.mt.)	Total Consumed Additional FAR Area (Sq.mt.)	Trmt (No.)
Ground Floor	71.50	59.91	11.59	11.59	11.59	01
First Floor	71.49	0.00	71.49	71.49	71.49	00
Second Floor	71.49	0.00	71.49	71.49	71.49	01
Terrace Floor	0.00	0.00	0.00	0.00	0.00	00
Total :	214.48	59.91	154.57	154.57	154.57	02
Total Number of Same Buildings	1					
Total :	214.48	59.91	154.57	154.57	154.57	02

LTP NAME AND SIGNATURE	STRUCTURAL ENG'S NAME AND SIGNATURE	BUILDER NAME AND SIGNATURE	DIGITAL SIGNATURE
Amarjeet Balmuchu JNAC/ARC/0008/2018			