

SITE

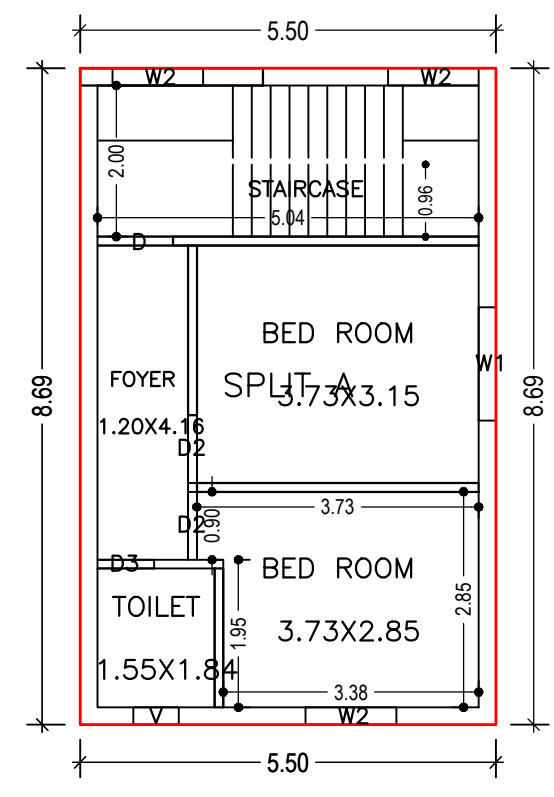

SECOND FLOOR PLAN (Proposed) (SCALE 1:100)

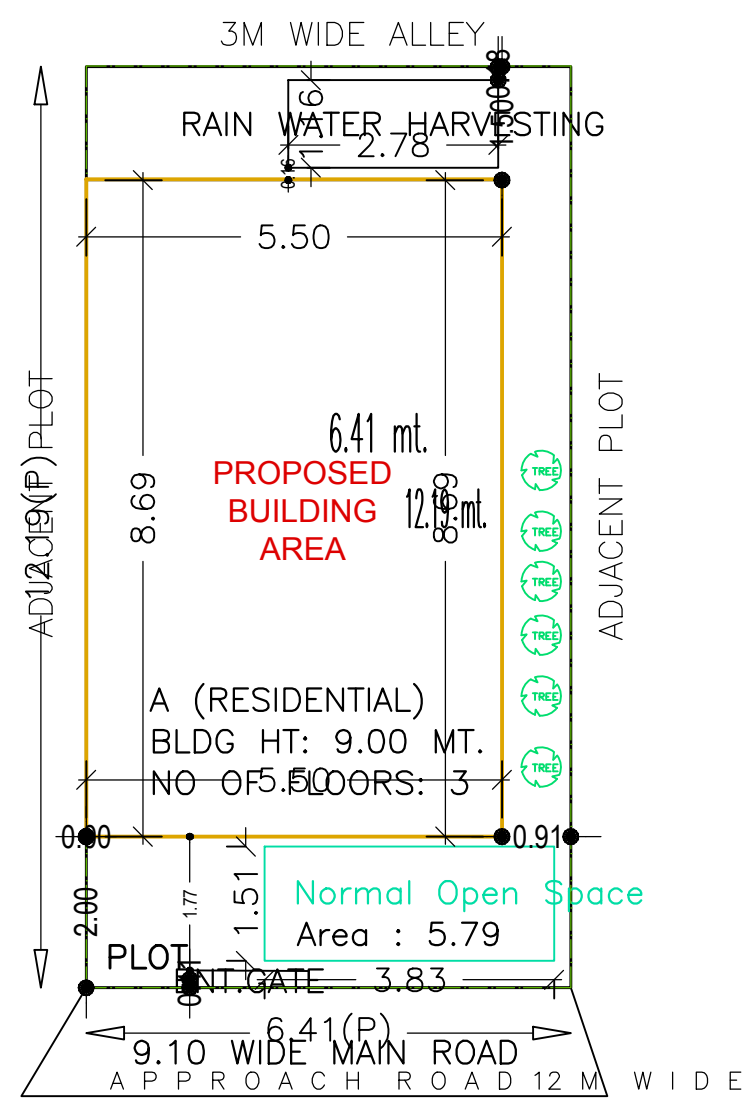
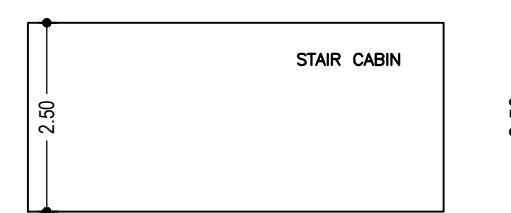

9.00 mt. from SL

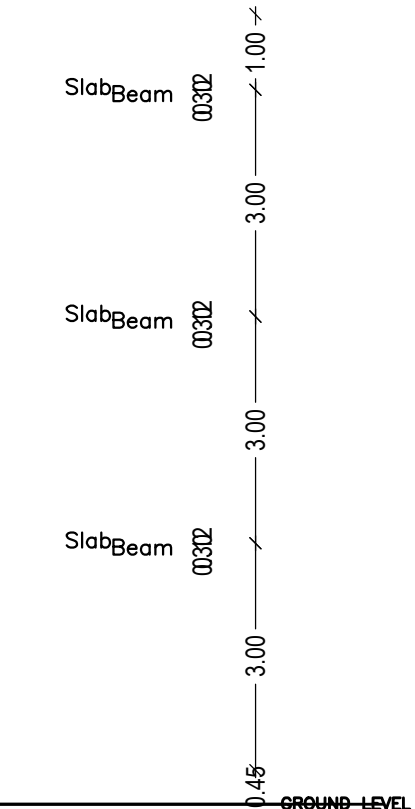

FAR & Tenement Details (Table 4c-1)

Building	No. of Same Bldg	Total Built Up Area (Sq.mt.)	Deductions (Area in Sq.mt.)	Proposed FAR Area (Sq.mt.)	Total FAR Area (Sq.mt.)	Total Consumed Additional FAR Area (Sq.mt.)	Tnmt (No.)
A (RESIDENTIAL)	1	143.31	34.24	109.07	109.07	109.07	01
Grand Total :	1	143.31	34.24	109.07	109.07	109.07	01

Proposal Basic Information

Proposal File No.	JNAC/BP/0043/W12/2021
Owner Name	MD SHAHID
Khata No	61
Plot No	2707
Village Name	SAKCHI
Use	Residential
SubUse	Bungalow/ Dwelling / Non Apartment

AREA STATEMENT JAMSHEDPUR NAC

VERSION NO :- 1.0.55
VERSION DATE: 16/10/2020

PROJECT DETAIL:
Region: JHARKHAND URBAN LOCAL BODIES
District: EAST SINGHBHUM
Authority: JAMSHEDPUR NAC
Inward_No: JNAC/BP/0043/W12/2021
Application Type: General Proposal
Project Type: Building Permission
Nature of Development: New
Location of Development Area: Old Area

Plot Use: Residential
Plot SubUse: Bungalow/ Dwelling / Non Apartment
PlotNearby/ReligiousStructure: NA
PlotSubPlot No: 2707
North: Plot No. - Alley
South: Road Width - 9.1
East: Plot No. - 303
West: Road Width - 301

AREA DETAILS:		SQ.MT.
AREA OF PLOT (Minimum)	(A)	78.11
NET AREA OF PLOT(Gross Plot Area - Deduction from Gross Plot area)	(A-Deductions)	78.11
Deduction for Balance Plot Area(from Gross Plot Area)		
Common Plot		5.79
Total		5.79
BALANCE AREA OF PLOT(Net Plot Area - Recreational/Amenity space)	(A-Deductions)	72.32
PLOT AREA FOR COVERAGE(Net Plot Area)	(A-Deductions)	78.11
Plot Area for FAR (Net Plot Area + Road Widening Area)	(A-Deductions)	78.11
COVERAGE CHECK		
Permissible Coverage area (70.00 %)		54.68
Proposed Coverage Area (61.16 %)		47.77
Total Prop. Coverage Area (61.16 %)		47.77
Balance coverage area (8.85 %)		6.91
FAR CHECK		
Perm. FAR Area (2.50)		195.27
Total Perm. FAR area		195.27
Residential FAR		109.07
Proposed FAR Area		109.07
Total Proposed FAR Area		109.07
Consumed FAR (Factor)		1.40
Balance FAR Area		86.20
BUILT UP AREA CHECK		
Total Proposed BuiltUp Area		143.31
ARCHITECT (Regd)		Amarjeet Balmuchu
ENGINEER (Regd)		
SUPERVISOR (Regd)		
OWNER (Regd)		MD SHAHID
DEVELOPMENT AUTHORITY		LOCAL BODY

SITE PLAN SCALE: 1:150

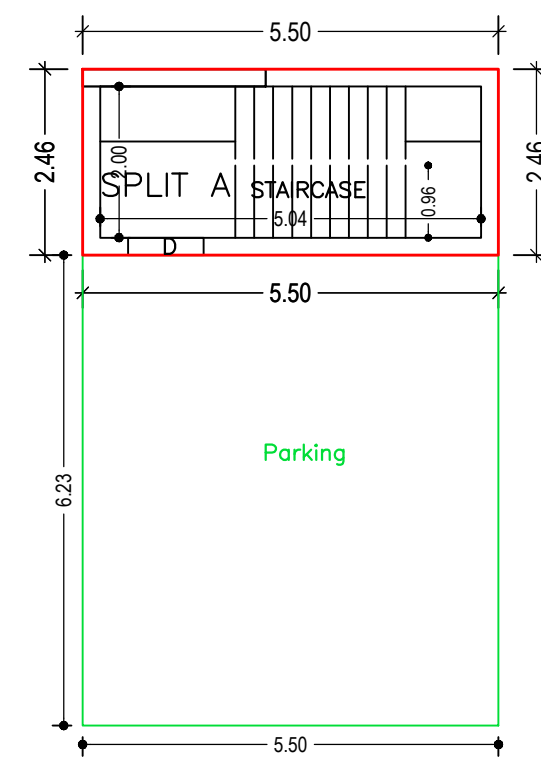

GROUND FLOOR PLAN (Proposed) (SCALE 1:100)

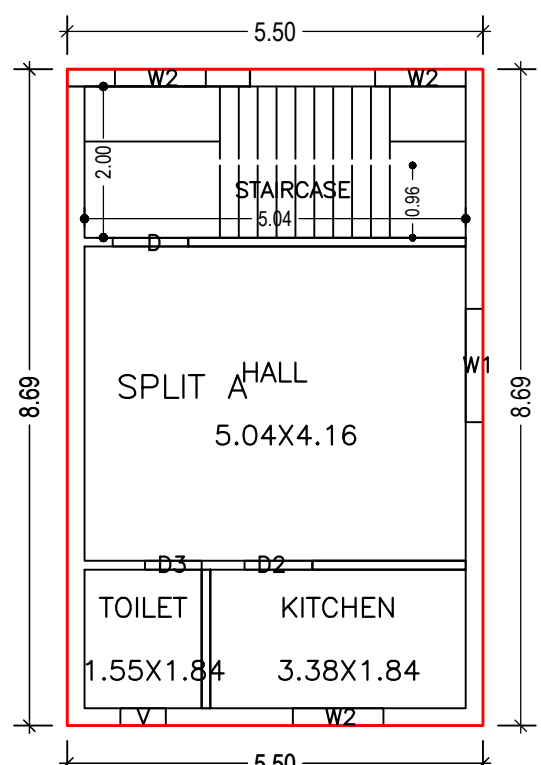

FIRST FLOOR PLAN (Proposed) (SCALE 1:100)

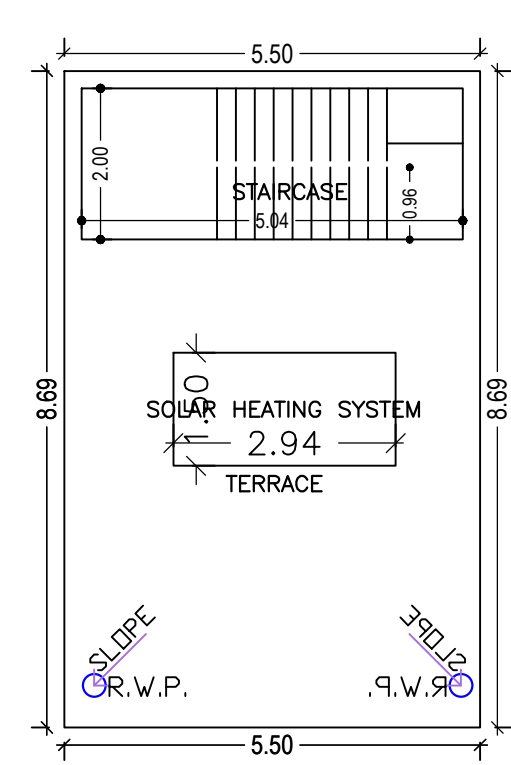

TERRACE FLOOR PLAN (Proposed) (SCALE 1:100)



MOUZA PLAN NTS

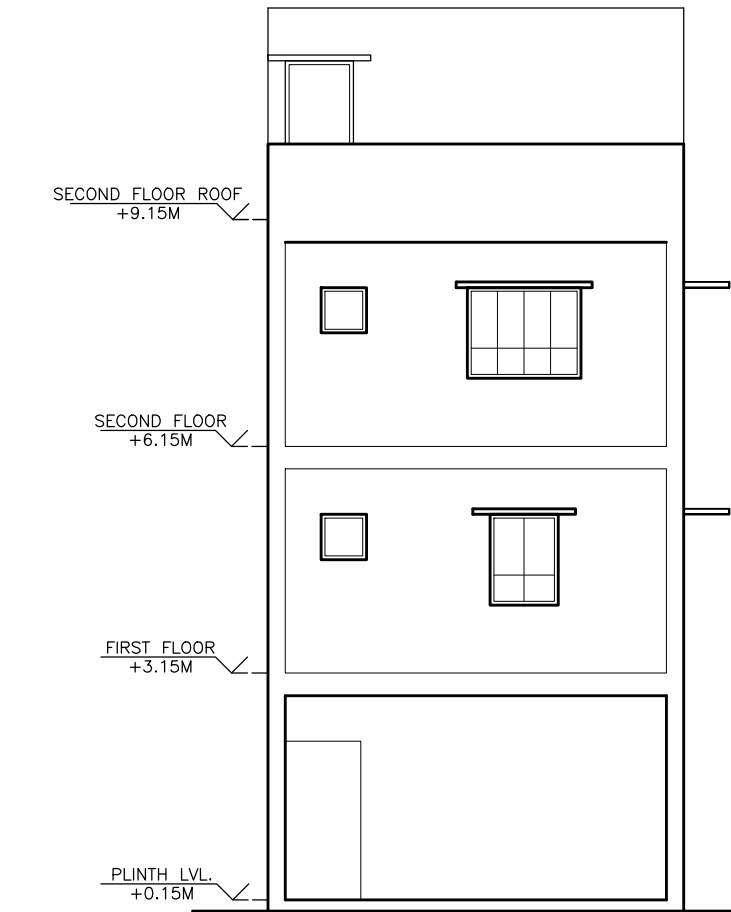

FRONT ELEVATION SCALE- 1:75

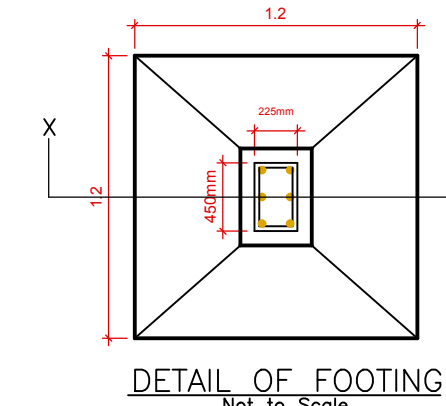

DETAIL OF FOOTING Not to Scale

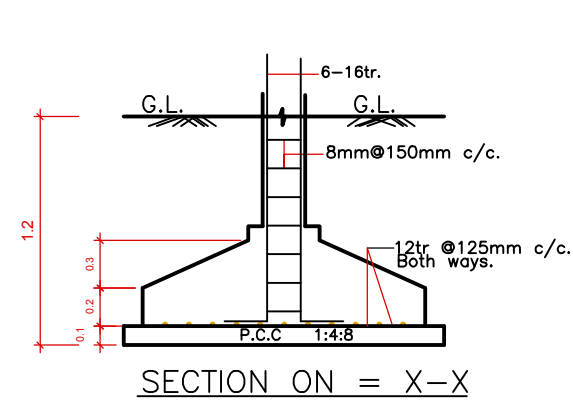

SECTION ON = X-X

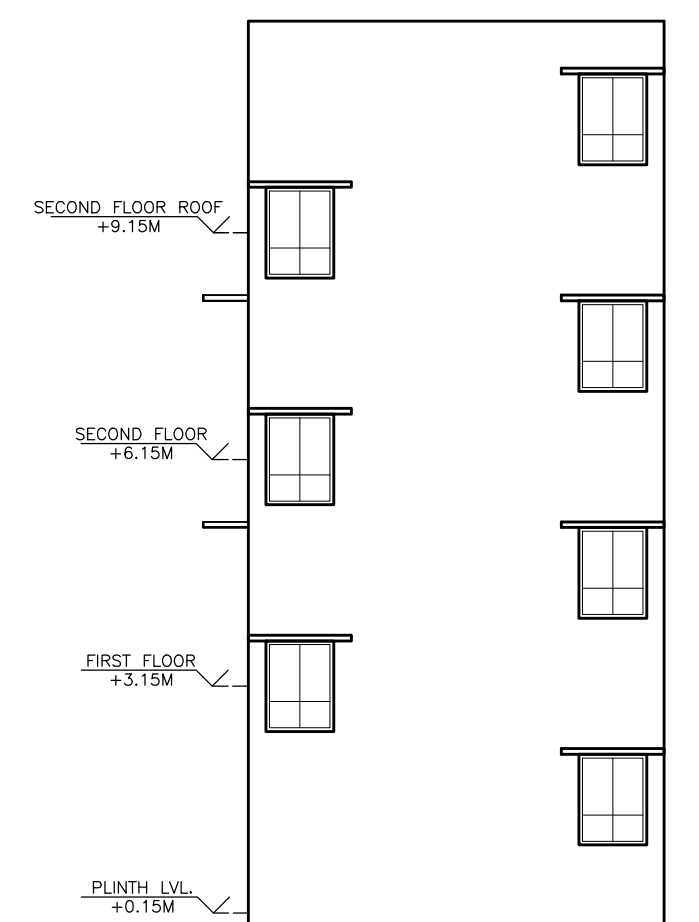

REAR ELEVATION SCALE- 1:75

COLOR INDEX

PLOT BOUNDARY	Black
ABUTTING ROAD	Green
PROPOSED CONSTRUCTION	Red
COMMON PLOT	Yellow
ROAD WIDENING AREA	Blue
EXISTING (To be retained)	Light Blue
EXISTING (To be demolished)	Light Yellow

Buildingwise Floor FAR Details

Floor Name	Building Name A (RESIDENTIAL)		Total	
	Proposed Built Up Area (Sq.mt.)	Proposed FAR Area (Sq.mt.)	Total Proposed Built Up Area (Sq.mt.)	Total FAR Area (Sq.mt.)
Ground Floor	47.77	13.53	47.77	13.53
First Floor	47.77	47.77	47.77	47.77
Second Floor	47.77	47.77	47.77	47.77
Terrace Floor	0.00	0.00	0.00	0.00
Total :	143.31	109.07	143.31	109.07

Building USE/SUBUSE Details

Building Name	Building Use	Building SubUse	Building Structure
A (RESIDENTIAL)	Residential	Bungalow/ Dwelling / Non Apartment	Non-Highrise

Building :A (RESIDENTIAL)

Floor Name	Total Built Up Area (Sq.mt.)	Deductions (Area in Sq.mt.)		Proposed FAR Area (Sq.mt.)	Total FAR Area (Sq.mt.)	Total Consumed Additional FAR Area (Sq.mt.)	Tnmt (No.)
		Parking	Resi.				
Ground Floor	47.77	34.24	13.53	13.53	13.53	13.53	01
First Floor	47.77	0.00	47.77	47.77	47.77	47.77	00
Second Floor	47.77	0.00	47.77	47.77	47.77	47.77	00
Terrace Floor	0.00	0.00	0.00	0.00	0.00	0.00	00
Total :	143.31	34.24	109.07	109.07	109.07	109.07	01
Total Number of Same Buildings	1						
Total :	143.31	34.24	109.07	109.07	109.07	109.07	01

SCHEDULE OF DOOR:

BUILDING NAME	NAME	LENGTH	HEIGHT	NOS
A (RESIDENTIAL)	D3	0.75	2.10	02
A (RESIDENTIAL)	D2	0.90	2.10	03
A (RESIDENTIAL)	D	1.00	2.10	02

SCHEDULE OF WINDOW/VENTILATION:

BUILDING NAME	NAME	LENGTH	HEIGHT	NOS
A (RESIDENTIAL)	V	0.60	1.20	02
A (RESIDENTIAL)	W2	1.20	1.20	06
A (RESIDENTIAL)	W1	1.50	1.20	02

UnitBUA Table for Building :A (RESIDENTIAL)

FLOOR	Name	UnitBUA Type	UnitBUA Area	Carpet Area	No. of Rooms	No. of Tenement
GROUND FLOOR PLAN	SPLIT A	FLAT	96.49	93.70	0	1
FIRST FLOOR PLAN	SPLIT A	FLAT	0.00	0.00	3	0
SECOND FLOOR PLAN	SPLIT A	FLAT	0.00	0.00	4	0
Total:	-	-	96.49	93.70	7	1

LTP NAME AND SIGNATURE	STRUCTURAL ENG'S NAME AND SIGNATURE	BUILDER NAME AND SIGNATURE	DIGITAL SIGNATURE
Amarjeet Balmuchu JNAC/ARC/0008/2018			