

Proposal Basic Information	
Proposal File No.	JNAC/BP/0024/W12/2021
Owner Name	(1) SRI PARDIP KUMAR LAL (2) SRI NARENDRA KUMAR AND SRI INDER KUMAR
Khata No	61
Plot No	3647
Village Name	Sitaramdera
Use	Residential
SubUse	Bungalow/ Dwelling / Non Apartment

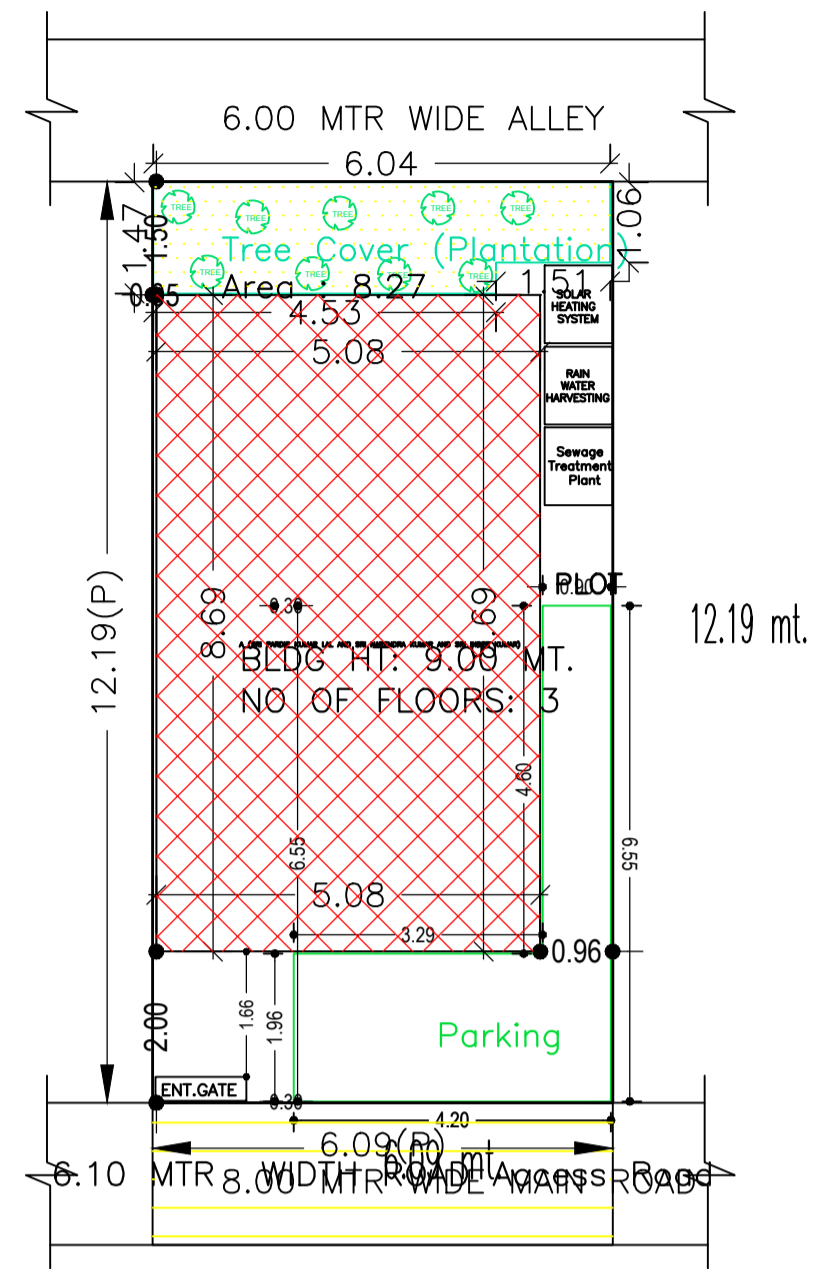

SITE PLAN

AREA STATEMENT		VERSION NO.: 1.0.61
JAMSHEDPUR NAC		VERSION DATE: 16/10/2020
PROJECT DETAIL:		
Region: JHARKHAND URBAN	Plot Use: Residential	
LOCAL BODIES	Plot SubUse: Bungalow/ Dwelling / Non Apartment	
District: EAST SINGHBHUM	PlotNearbyReligiousStructure: NA	
Authority: JAMSHEDPUR NAC	Plot/SubPlot No: 3647	
Inward_No: JNAC/BP/0024/W12/2021	North: Road Width - 6.0 MTR WIDE ALLEY	
Application Type: General Proposal	South: Road Width - 8.0 MTR WIDE MAIN ROAD	
Project Type: Building Permission	East: -	
Nature of Development: New	West: -	
Location of Development Area: Old Area		
AREA DETAILS:		
AREA OF PLOT (Minimum)	(A)	74.17
NET AREA OF PLOT(Gross Plot Area - Deduction from Gross Plot area)	(A-Deductions)	74.17
Deduction for Balance Plot Area(from Gross Plot Area)		
Common Plot		8.27
Total	(A-Deductions)	8.27
	(A-Deductions)	65.90
PLOT AREA FOR COVERAGE(Net Plot Area)	(A-Deductions)	74.17
Plot Area for FAR (Net Plot Area + RoadWidening Area)	(A-Deductions)	74.17
COVERAGE CHECK		
Proposed Coverage Area ( 59.48 % )		44.12
Total Prop. Coverage Area ( 59.48 % )		44.12
Balance coverage area ( 10.52 % )		7.80
FAR CHECK		
Perm. FAR Area ( 2.50 )		185.42
		185.42
Residential FAR		88.24
Proposed FAR Area		97.37
Total Proposed FAR Area		97.37
Consumed FAR (Factor)		1.31
Balance FAR Area		88.05
BUILT UP AREA CHECK		
Total Proposed BuiltUp Area		132.36
ARCHITECT (Regd)	Ajit Kumar Dhar	
ENGINEER (Regd)		
SUPERVISOR (Regd)		
OWNER (Regd)	(1) SRI PARDIP KUMAR LAL (2) SRI NARENDRA KUMAR (3) SRI INDER KUMAR	
DEVELOPMENT AUTHORITY		LOCAL BODY

FAR & Tenement Details (Table 4c-1)

Building	No. of Same Bldg	Total Built Up Area (Sq.mt.)	Deductions (Area in Sq.mt.)			Total FAR Area (Sq.mt.)	Total Consumed Additional FAR Area (Sq.mt.)	Trmt (No.)
			Parking	Resi.	Stair			
A (SRI PARDIP KUMAR LAL AND SRI NARENDRA KUMAR AND SRI INDER KUMAR)	1	132.36	34.98	88.24	9.14	97.38	97.38	01
Grand Total :	1	132.36	34.98	88.24	9.14	97.38	97.38	01

COLOR INDEX	
PLOT BOUNDARY	Black
ABUTTING ROAD	Green
PROPOSED CONSTRUCTION	Red
COMMON PLOT	Yellow
ROAD WIDENING AREA	Orange
EXISTING (To be retained)	Blue
EXISTING (To be demolished)	Light Blue

Buildingwise Floor FAR Details

Floor Name	Building Name		Total	
	A (SRI PARDIP KUMAR LAL AND SRI NARENDRA KUMAR AND SRI INDER KUMAR)	Proposed FAR Area (Sq.mt.)	Total Proposed Built Up Area (Sq.mt.)	Total FAR Area (Sq.mt.)
Ground Floor	44.12	9.14	44.12	9.14
First Floor	44.12	44.12	44.12	44.12
Second Floor	44.12	44.12	44.12	44.12
Terrace Floor	0.00	0.00	0.00	0.00
Total :	132.36	97.38	132.36	97.38

Building USE/SUBUSE Details

Building Name	Building Use	Building SubUse	Building Structure
A (SRI PARDIP KUMAR LAL AND SRI NARENDRA KUMAR AND SRI INDER KUMAR)	Residential	Residential Bldg/Apartment	Non-Highrise

LTP NAME AND SIGNATURE	STRUCTURAL ENG'S NAME AND SIGNATURE	BUILDER NAME AND SIGNATURE	DIGITAL SIGNATURE
Ajit Kumar Dhar JNAC/DFTMN/0009/2017			

Proposal Basic Information	
Proposal File No.	JNAC/BP/0024/W12/2021
Owner Name	(1) SRI PARDIP KUMAR LAL (2) SRI NARENDRA KUMAR AND SRI INDER KUMAR
Khata No	61
Plot No	3647
Village Name	Sitaramdera
Use	Residential
SubUse	Bungalow/ Dwelling / Non Apartment

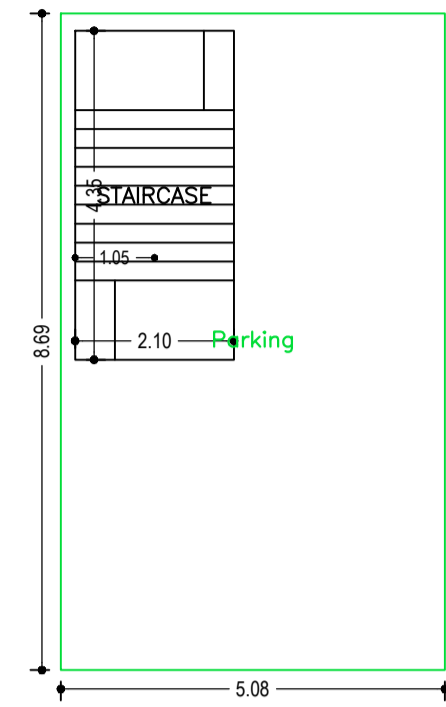

GROUND FLOOR PLAN  
(SCALE 1:100)

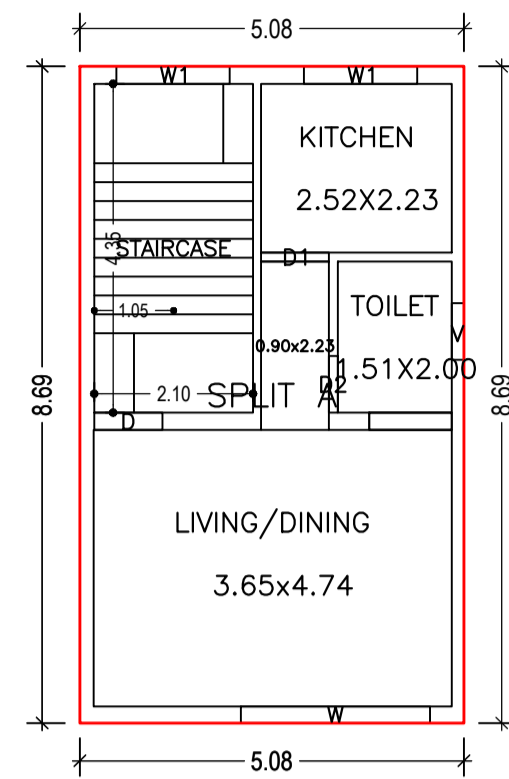

FIRST FLOOR PLAN  
(Proposed)  
(SCALE 1:100)

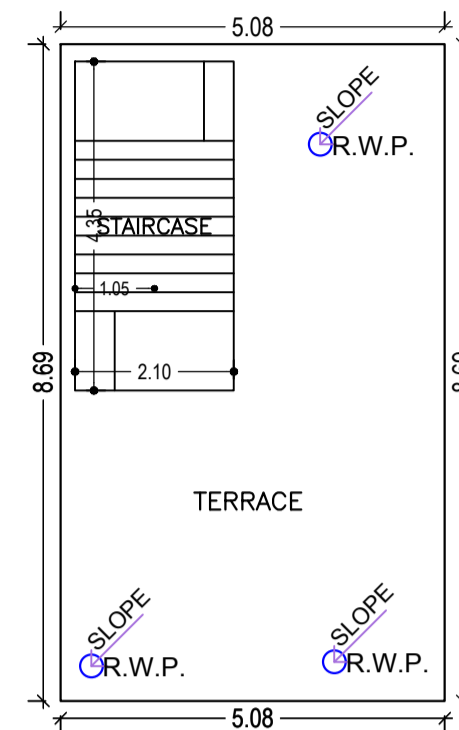

TERRACE FLOOR PLAN  
(SCALE 1:100)

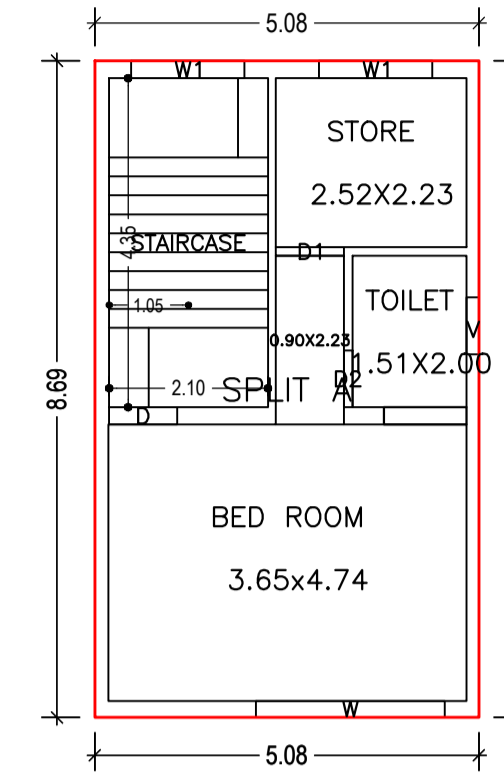

SECOND FLOOR PLAN  
(Proposed)  
(SCALE 1:100)

Building :A (SRI PARDIP KUMAR LAL AND SRI NARENDRA KUMAR AND SRI INDER KUMAR)

Floor Name	Total Built Up Area (Sq.mt.)	Deductions (Area in Sq.mt.)		Proposed FAR Area (Sq.mt.)			Total Consumed Additional FAR Area (Sq.mt.)	Trmt (No.)
		Parking	Resi.	Stair	Total FAR Area (Sq.mt.)	Total Consumed Additional FAR Area (Sq.mt.)		
Ground Floor	44.12	34.98	0.00	9.14	9.14	9.14	00	
First Floor	44.12	0.00	44.12	0.00	44.12	44.12	01	
Second Floor	44.12	0.00	44.12	0.00	44.12	44.12	00	
Terrace Floor	0.00	0.00	0.00	0.00	0.00	0.00	00	
Total :	132.36	34.98	88.24	9.14	97.38	97.38	01	
Total Number of Same Buildings :	1							
Total :	132.36	34.98	88.24	9.14	97.38	97.38	01	

LTP NAME AND SIGNATURE	STRUCTURAL ENG'S NAME AND SIGNATURE	BUILDER NAME AND SIGNATURE	DIGITAL SIGNATURE
Ajit Kumar Dhar JNAC/DFTMN/0009/2017			

Proposal Basic Information	
Proposal File No.	JNAC/BP/0024/W12/2021
Owner Name	(1) SRI PARDIP KUMAR LAL (2) SRI NARENDRA KUMAR AND SRI INDER KUMAR
Khata No	61
Plot No	3647
Village Name	Sitaramdera
Use	Residential
SubUse	Bungalow/ Dwelling / Non Apartment

SCHEDULE OF DOOR:

BUILDING NAME	NAME	LENGTH	HEIGHT	NOS
A (SRI PARDIP KUMAR LAL AND SRI NARENDRA KUMAR AND SRI INDER KUMAR)	D2	0.75	2.13	02
A (SRI PARDIP KUMAR LAL AND SRI NARENDRA KUMAR AND SRI INDER KUMAR)	D1	0.90	2.13	02
A (SRI PARDIP KUMAR LAL AND SRI NARENDRA KUMAR AND SRI INDER KUMAR)	D	0.90	2.13	02

SCHEDULE OF WINDOW/VENTILATION:

BUILDING NAME	NAME	LENGTH	HEIGHT	NOS
A (SRI PARDIP KUMAR LAL AND SRI NARENDRA KUMAR AND SRI INDER KUMAR)	V	0.75	2.70	02
A (SRI PARDIP KUMAR LAL AND SRI NARENDRA KUMAR AND SRI INDER KUMAR)	W1	1.50	2.70	04
A (SRI PARDIP KUMAR LAL AND SRI NARENDRA KUMAR AND SRI INDER KUMAR)	W	2.50	2.70	02

UnitBUA Table for Building :A (SRI PARDIP KUMAR LAL AND SRI NARENDRA KUMAR AND SRI INDER KUMAR)

FLOOR	Name	UnitBUA Type	UnitBUA Area	Carpet Area	No. of Rooms	No. of Tenement
FIRST FLOOR PLAN	SPLIT A	FLAT	57.73	57.23	3	1
SECOND FLOOR PLAN	SPLIT A	FLAT	0.00	0.00	3	0
Total:	-	-	57.73	57.23	6	1

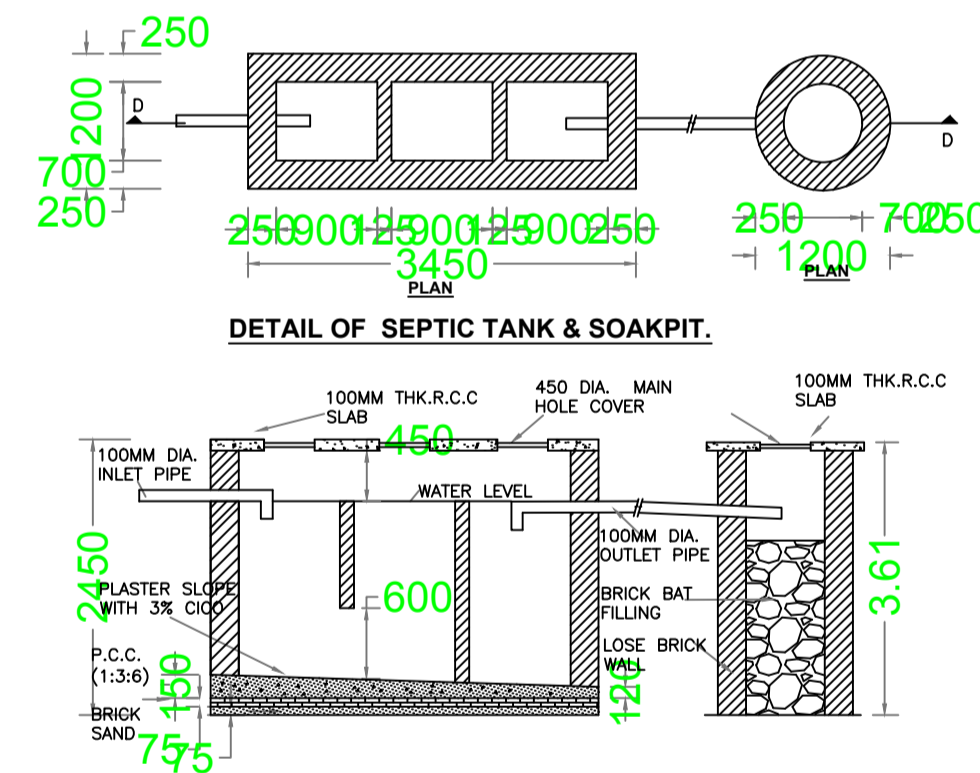
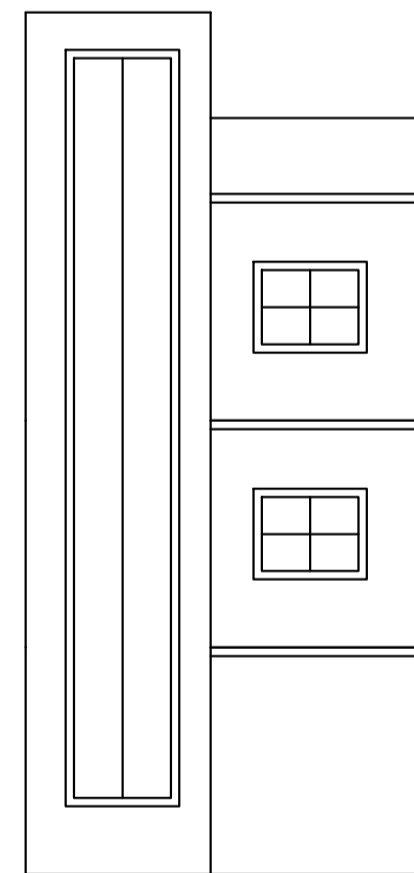
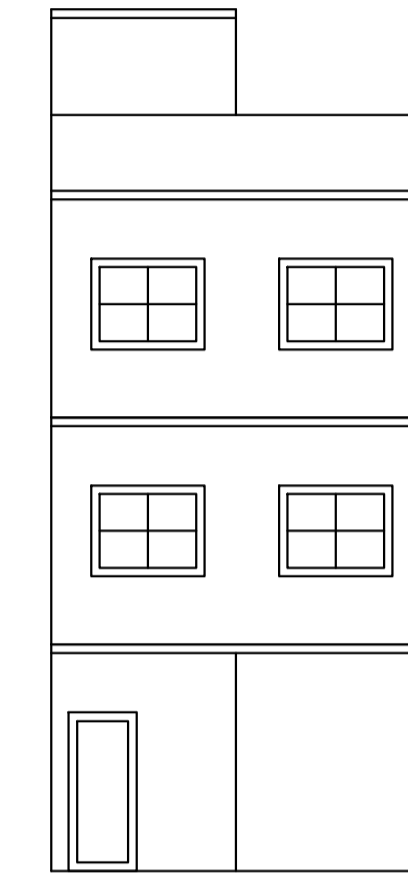
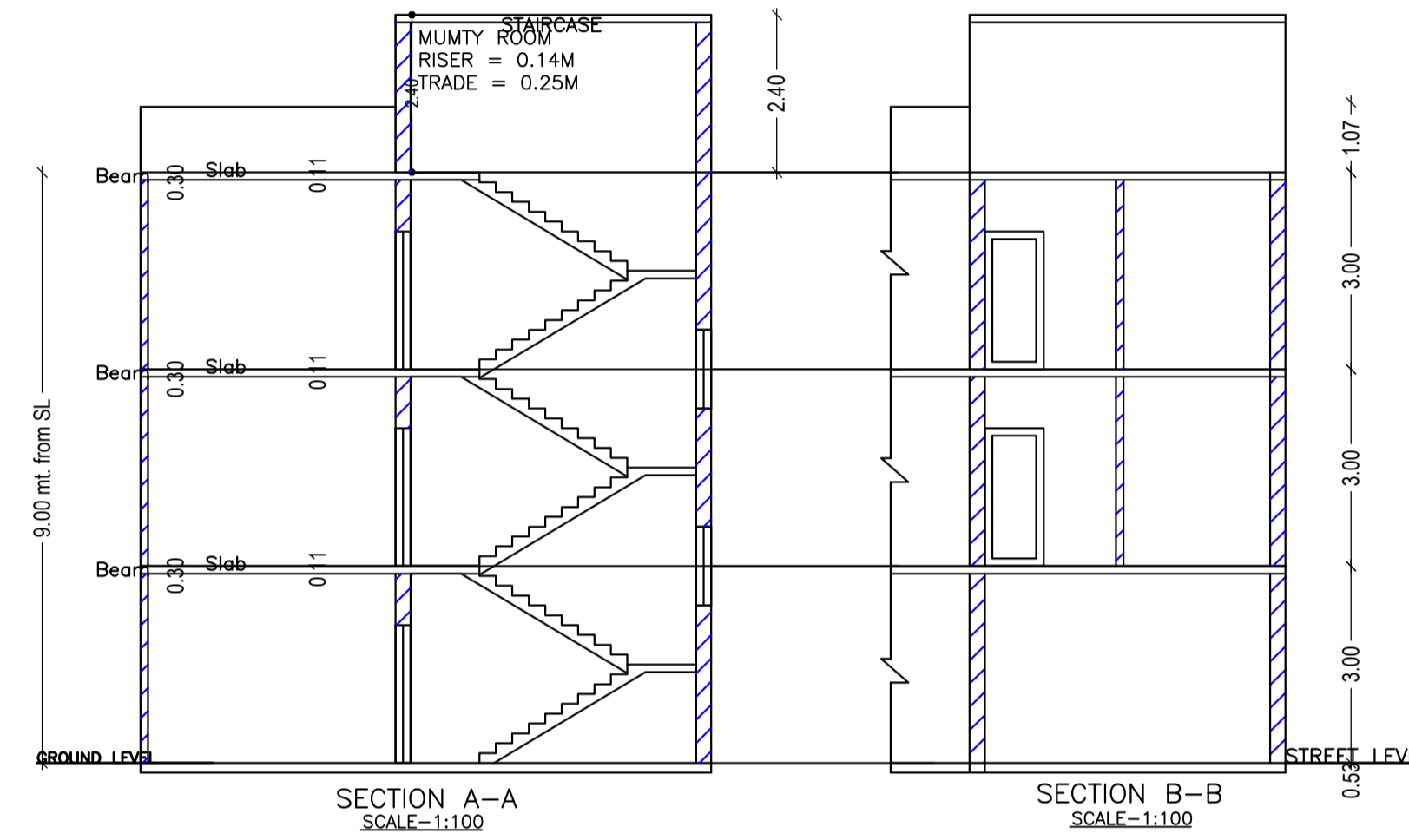

LTP NAME AND SIGNATURE	STRUCTURAL ENG'S NAME AND SIGNATURE	BUILDER NAME AND SIGNATURE	DIGITAL SIGNATURE
Ajit Kumar Dhar JNAC/DFTMN/0009/2017			

Proposal Basic Information	
Proposal File No.	JNAC/BP/0024/W12/2021
Owner Name	(1) SRI PARDIP KUMAR LAL (2) SRI NARENDRA KUMAR (3) SRI INDER KUMAR
Khata No	61
Plot No	3647
Village Name	Sitaramdera
Use	Residential
SubUse	Bungalow/ Dwelling / Non Apartment

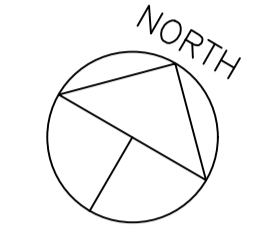
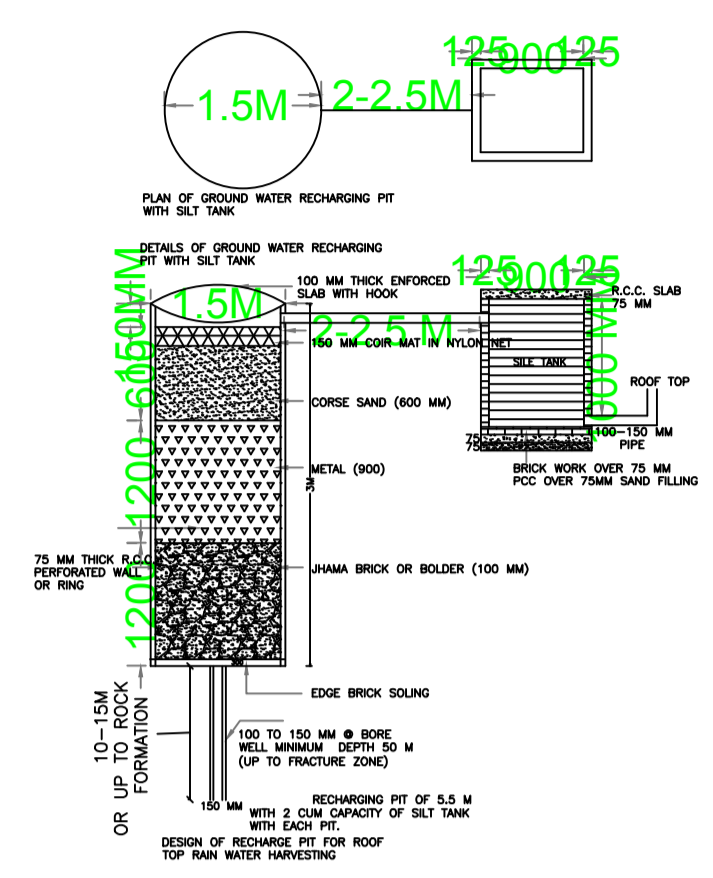
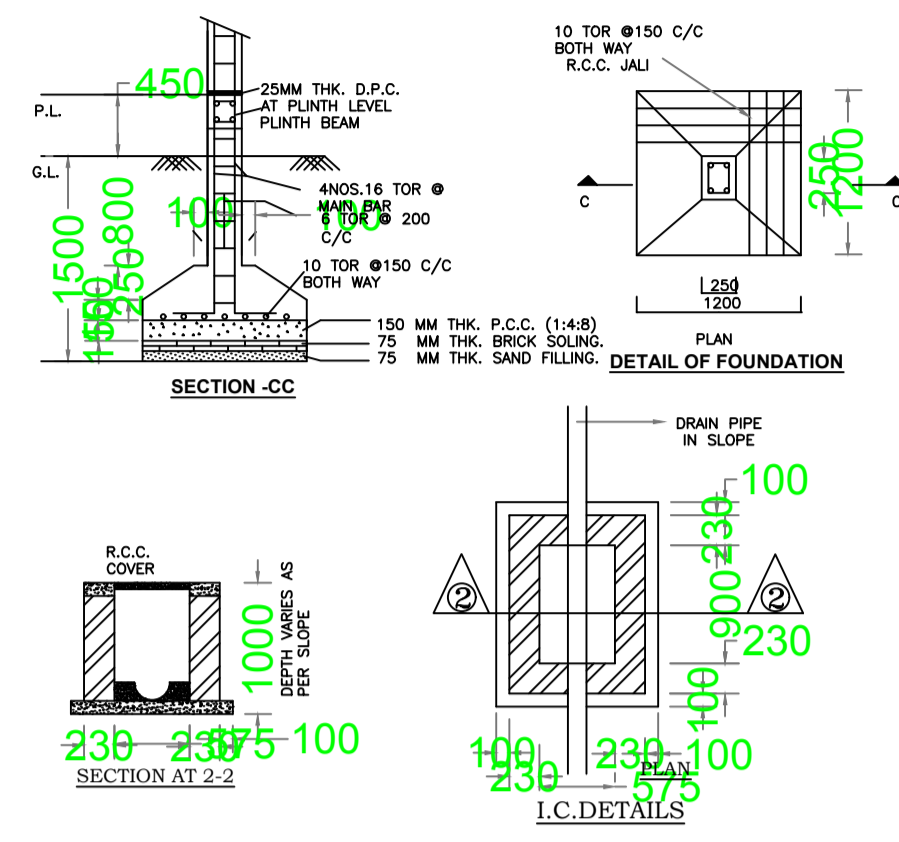
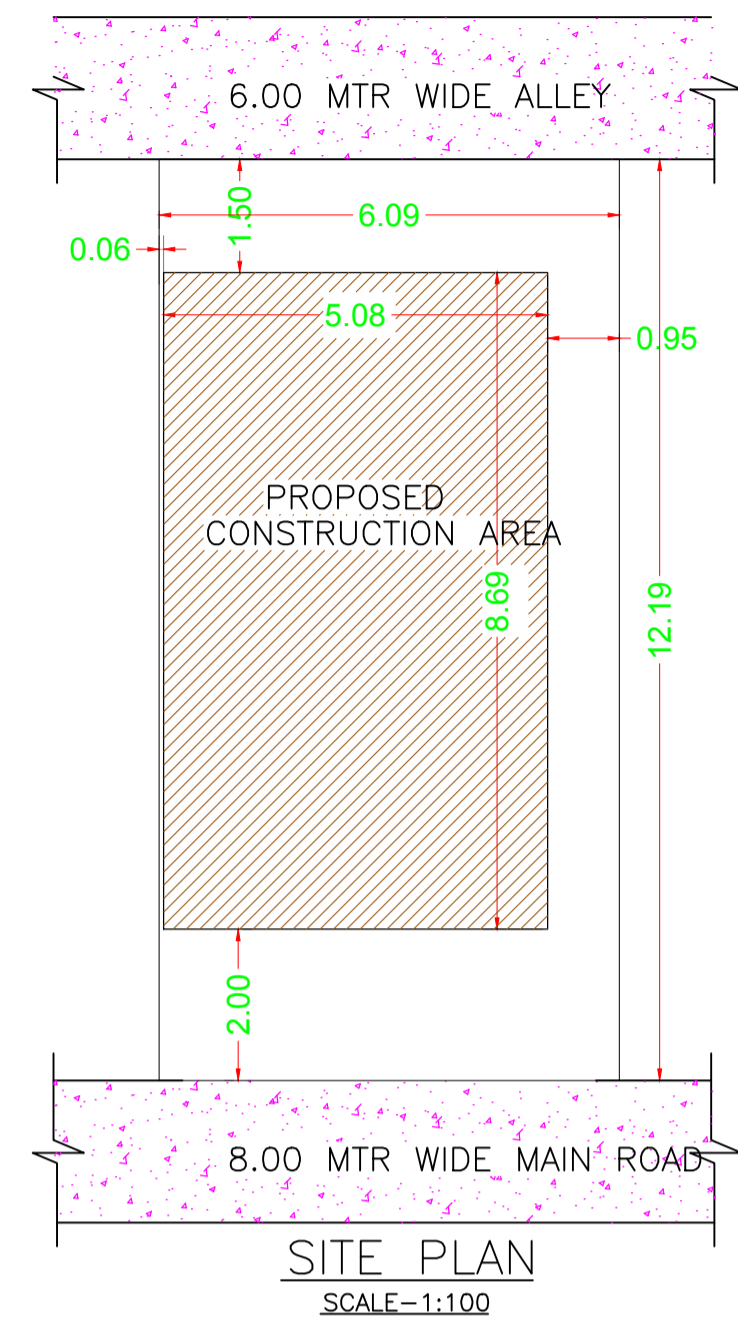

MOUZA PLAN  
SCALE- NTS

LTP NAME AND SIGNATURE	STRUCTURAL ENG'S NAME AND SIGNATURE	BUILDER NAME AND SIGNATURE	DIGITAL SIGNATURE
Ajit Kumar Dhar JNAC/DFTMN/0009/2017			