

Project Title : TUHINA BANERJEE AND PROVAS MUKHERJEE

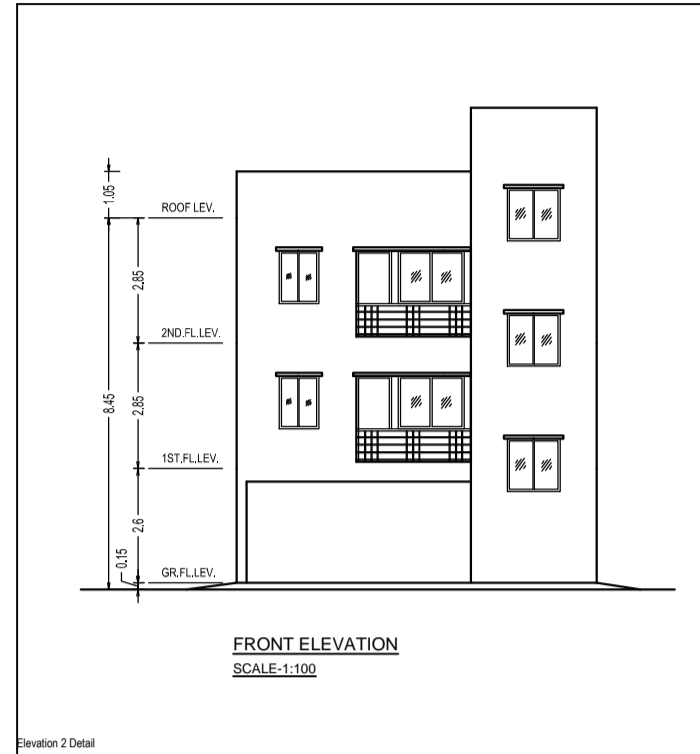
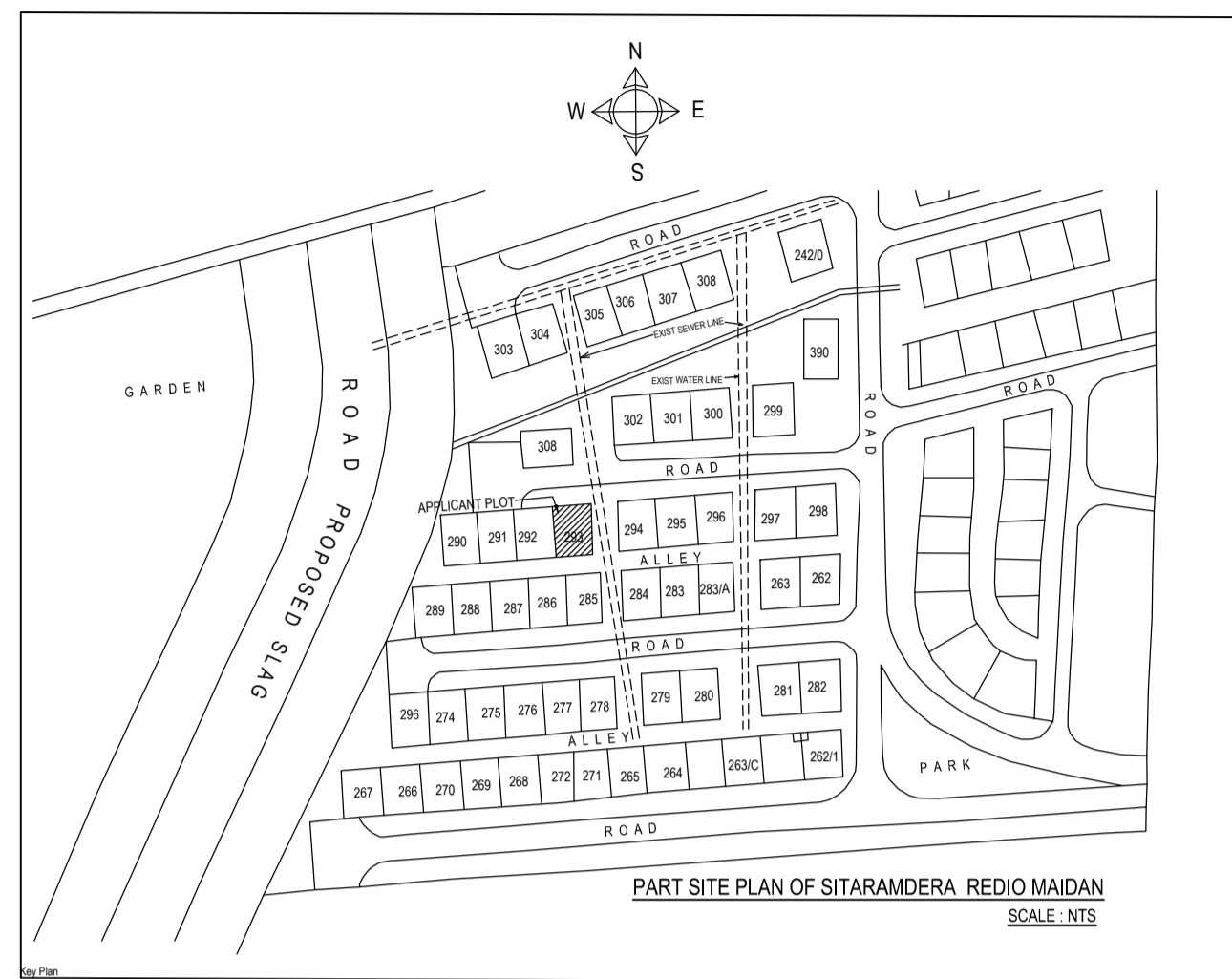

NOTE
 1. FOUNDATION & R.C.C. AS PER STRUCTURAL ENGS. SPECIFICATION
 2. ALL DIMENSIONS IN Mts.
 3. DRAWING NOT TO BE SCALED

OFFICE USE

PROJECT DETAIL:		VERSION NO. 1.01	VERSION DATE: 16/10/2020
Project No.:	Residential		
Region:	JAMSHEDPUR LOCAL BODIES	Plot Size:	Bungalow / Dwelling / Non-Apartment
Project Type:	RESIDENTIAL	Location Zone:	Residential Zone - R4
Application Type:	General Proposal	Abutting Road Width:	15.00
Project Name:	Banerjee & Mukherjee	Plot No.:	250
Nature of Development:	New	Revised Survey No./Survey No.:	-
Location:	Old Area	Town No.:	-
Sub Location:	Old	Plotting No.:	-
Wing/Block Name:	-	Khata No.:	-
Well No.:	-	North:	-
Road/Street:	-	South:	-
		East:	-
		West:	-

AREA DETAILS:		UNIT	VALUE
Area of Plot (Minimum)	30	Sq.Mt	111.36
Net Plot Area (Less Plot Area Deduction from Gross Plot Area)	(A-Deductions)	(A-Deductions)	111.36
G.P. Area			111.36
Plot Area			111.36
Balance Plot Area (Net Plot Area - Proposed Area)	(A-Deductions)	(A-Deductions)	97.85
Plot Area to Coverage (Net Plot Area - Deductions)	(A-Deductions)	(A-Deductions)	111.36
Plot Area for FSI (Net Plot Area - Deductions)	(A-Deductions)	(A-Deductions)	111.36
COVERED AREA CHECK			
Proposed Coverage Area (65.14 %)			72.57
Total Coverage Area (65.14 %)			72.57
FAR CHECK			
Proposed Area of FAR			155.95
Total Area of FAR			155.95
SOIL TEST AREA CHECK			
Total Proposed Built Up Area			210.93
HEIGHT LIMITS (As per Section 46)			
Development Authority			LOCAL BODY

COLOR INDEX	
PROPOSED WORK (COVERAGE AREA)	[Symbol]
EXISTING (To be retained)	[Symbol]
EXISTING (To be demolished)	[Symbol]

PARKING CALCULATION:		
Car Parking	Prop. No.	Prop. Area
	2	25.00
Other Parking	1	25.98
Total Area	3	50.98

MARGIN DETAIL:					
Building/ Wing	Road Name	Front Margin	Rear Margin	Side Margin	Setback Margin
A/TUHINA BANERJEE AND PROVAS MUKHERJEE	H.R.D.A.	2.05	1.54	0.95	0.00

FAR & Tenement Details (Table 4c-1)							
Building	No. of Same Bldg	Total Built Up Area (Sq.Mt)	Deductions (Area in Sq.Mt)	Proposed FAR Area (Sq.Mt)	Area in FAR (Sq.Mt)	Total FAR Area (Sq.Mt)	Tenement (No.)
Grand Total	1	210.93	3.00	51.98	148.62	153.93	01

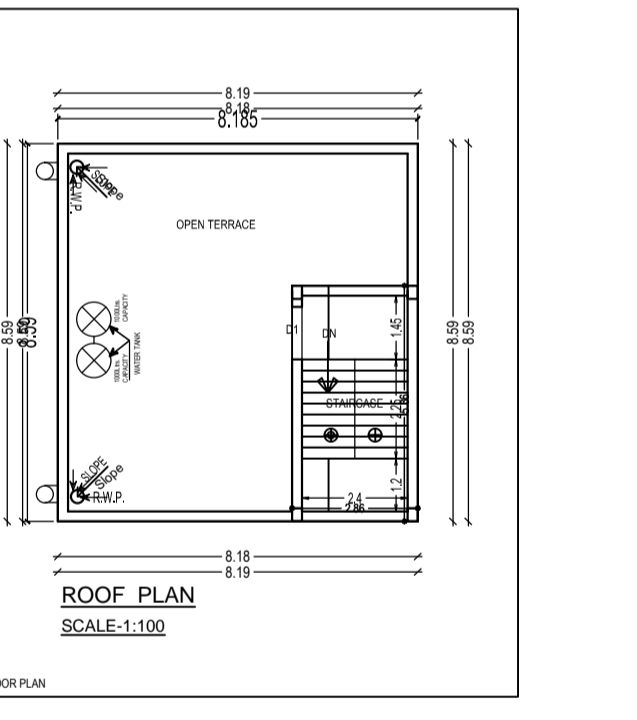
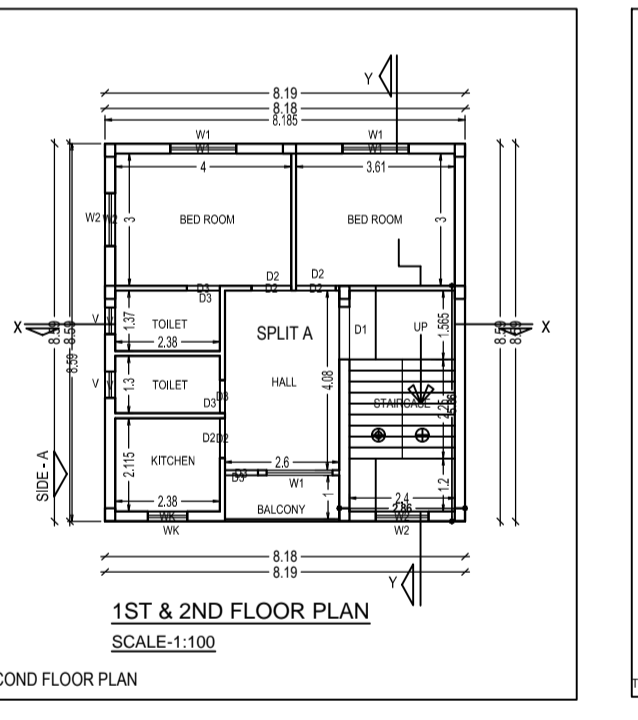
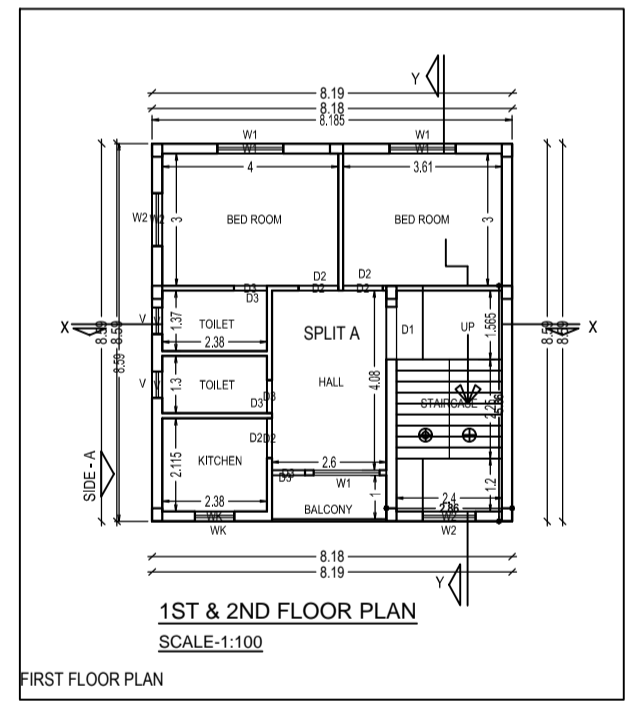
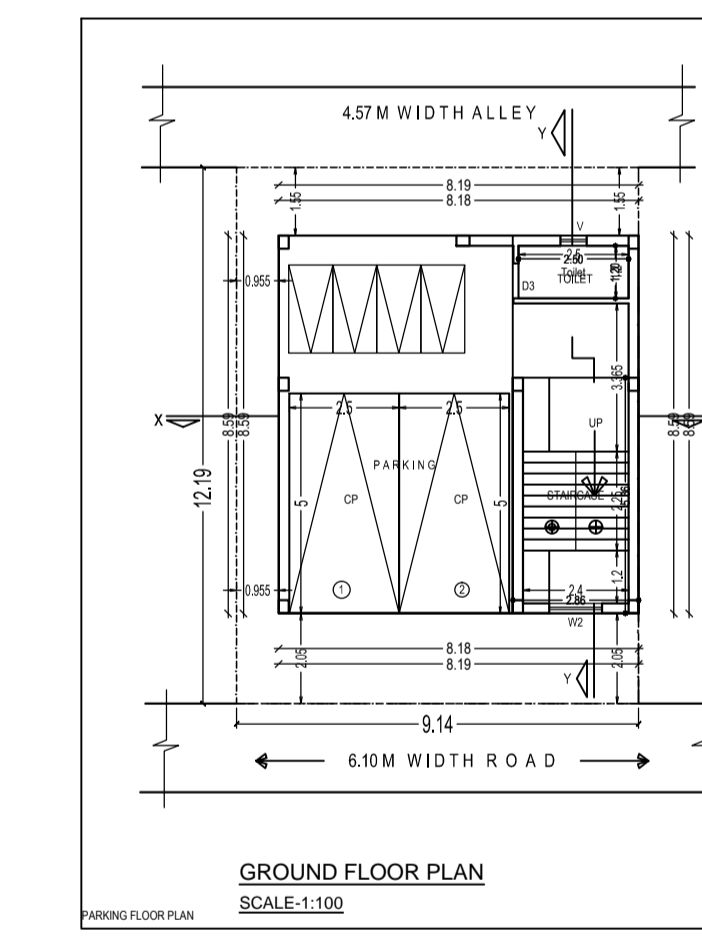
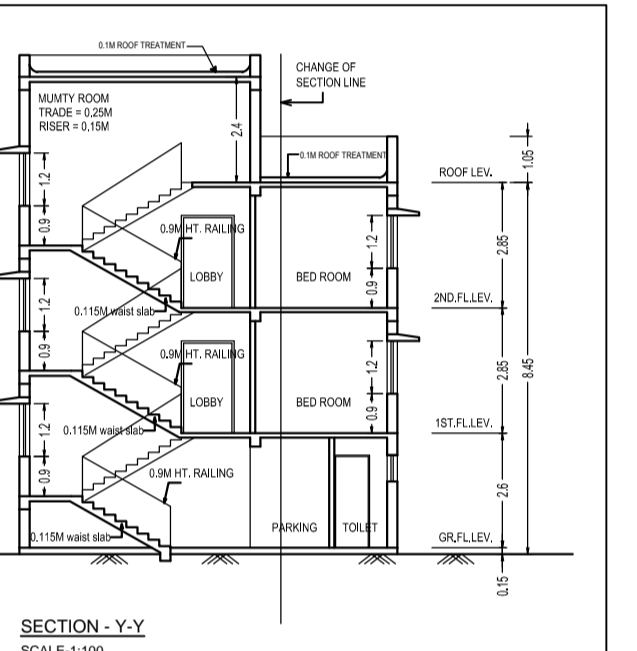
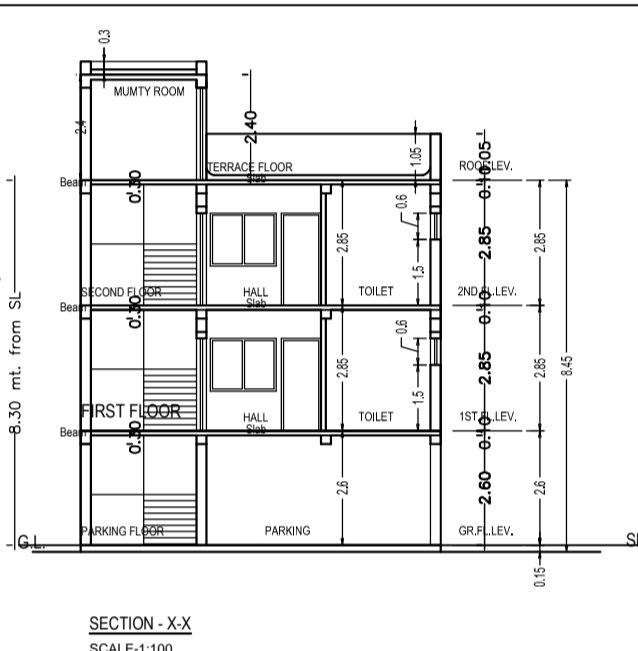
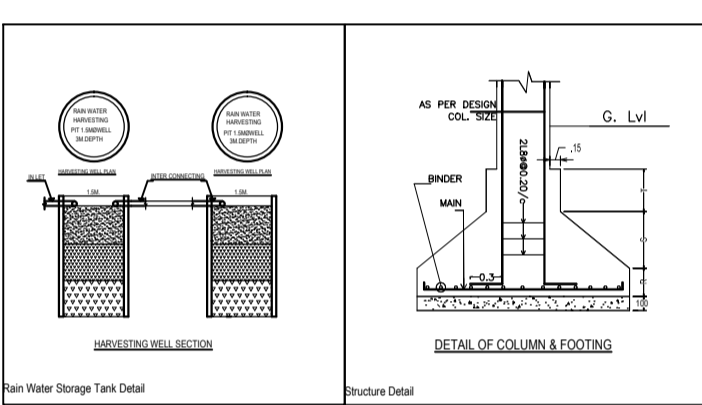

APPROVED:-

SPL OFFICER, J.N.A.C., JAMSHEDPUR
 OWNER / POAH

Signature of Applicant:-

GENERAL SPECIFICATION
 FOUNDATION: PLAIN CEMENT CONCRETE AS PER DESIGN
 R.C.C. COLUMN FOOTING & COLUMN AS PER STRUCTURAL DESIGN
 R.C.C. COLUMN & BEAMS AS PER STR. DESIGN
 SUPER STRUCTURE: R.C.C. WALL & 6.5 CM THK. PARTITION WALL IN CEMENT MORTAR
 R.C.C. ROOF SLAB AS PER STRUCTURAL DESIGN
 FLOOR: MOSAIC/GI/TILE/GRANITE/TILES/DIAG IN TOILET
 INTERNAL FINISH: CEMENT PLASTER WITH P.O.P & O.G.
 SANITARY: VITROUS CHINA CLAY SANITARY WARE G.I PIPE WATER SUPPLY
 P.V.C PIPE FOR SEWAGE DISPOSAL
 DOORS & WINDOW: AS PER SCHEDULE
 ELECTRICAL: COPPER WIRE WITH P.V.C. CONDUIT.

PROPOSED RESIDENTIAL BUILDING PLAN OF

L.K. SUMAN
 SHEET No- 01 / 01
 L.K. SUMAN
 Office - 1, Second Floor
 Basant Talika Complex,
 Sakchi, Jamshedpur
 Reg. No.- JNAC/001(T)/2016

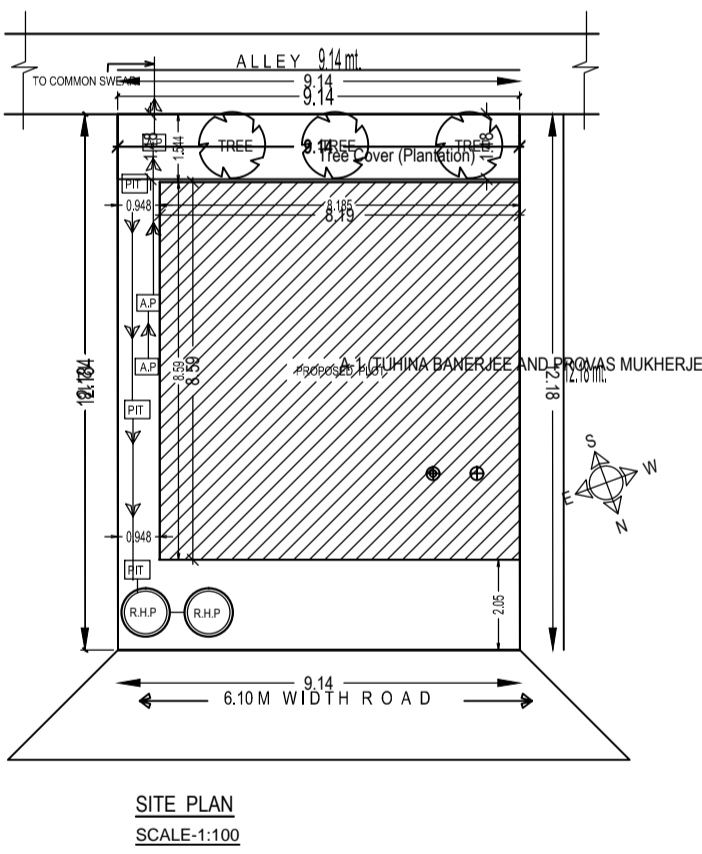

Building - A (TUHINA BANERJEE AND PROVAS MUKHERJEE)							
Part	Total Built Up Area (Sq.Mt)	Deductions (Area in Sq.Mt)	Proposed FAR Area (Sq.Mt)	Area in FAR (Sq.Mt)	Total FAR Area (Sq.Mt)	Tenement (No.)	Remarks
Parking	70.31	3.00	51.98	0.00	153.93	00	
First Floor	70.31	0.00	70.31	0.00	70.31	01	
Second Floor	70.31	0.00	70.31	0.00	70.31	00	
Roof	0.00	0.00	0.00	0.00	0.00	00	
Total	210.93	3.00	148.62	153.93	153.93	01	
Total	210.93	3.00	148.62	153.93	153.93	01	

SCHEDULE OF JOINERY:				
ITEM NO.	ITEM NAME	LENGTH	HEIGHT	NO. OF
01	W1	1.50	2.10	06
02	W2	0.90	2.10	06
03	W3	0.90	2.10	12

SCHEDULE OF JOINERY:				
ITEM NO.	ITEM NAME	LENGTH	HEIGHT	NO. OF
04	W4	1.20	1.20	04
05	W5	1.50	1.20	04
06	W6	1.50	1.20	04

UINBUA Table for Building - A (TUHINA BANERJEE AND PROVAS MUKHERJEE)					
FLOOR	Name	UINBUA Type	UINBUA Area	Carpet Area	No. of Tenement
FIRST FLOOR	SPLIT A	FLAT	148.62	126.99	7
TOTAL	-	-	148.62	126.99	14