

SITE PLAN  
SCALE:1:100  
(Scale - 1:200)

FAR & Tenement Details (Table 4c-1)

Building	No. of Same Bldg	Total Built Up Area (Sq.mt.)	Deductions (Area in Sq.mt.)	Proposed FAR Area (Sq.mt.)	Add Area In FAR (Sq.mt.)	Total FAR Area (Sq.mt.)	Total Consumed Additional FAR Area (Sq.mt.)	Tnmt (No.)
			Accessory Use Parking	Resi.	Stair			
A (TUHINA BANERJEE AND PROVAS MUKHERJEE)	1	210.93	3.00 53.82	140.62	13.49	154.11	154.11	01
Grand Total	1	210.93	3.00 53.82	140.62	13.49	154.11	154.11	01

Proposal Basic Information

Proposal File No.	JNAC/BP/0047/W11/2021
Owner Name	TUHINA BANERJEE & PROVAS MUKHERJEE
Khata No	Nil
Plot No	H. No.-293 Sitaramdera Radio Maidan
Village Name	Sitaramdera
Use	Residential
SubUse	Bungalow/ Dwelling / Non Apartment

AREA STATEMENT JAMSHEDPUR NAC	VERSION NO. 1.0.57 VERSION DATE: 16/10/2020	
PROJECT DETAIL:		
Region: JHARKHAND URBAN LOCAL BODIES	Plot Use: Residential	
District: EAST SINGHBHUM	Plot SubUse: Bungalow/ Dwelling / Non Apartment	
Authority: JAMSHEDPUR NAC	PlotNearby/ReligiousStructure: NA	
Inward_No: JNAC/BP/0047/W11/2021	Plot/SubPlot No: H. No.-293 Sitaramdera Radio Maidan	
Application Type: General Proposal	North: Road Width - 6.20	
Project Type: Building Permission	South: Survey No. - ALLEY	
Nature of Development: New	East: Survey No. - Open Space	
Location of Development Area: Old Area	West: Plot No. - 292	
AREA DETAILS:		
AREA OF PLOT (Minimum)	(A)	SQ.MT. 111.15
NET AREA OF PLOT(Gross Plot Area - Deduction from Gross Plot area)	(A-Deductions)	111.15
Deduction for Balance Plot Area(from Gross Plot Area)		
Common Plot Total		13.29
BALANCE AREA OF PLOT(Net Plot Area - Recreational/Amenity space)	(A-Deductions)	97.86
PLOT AREA FOR COVERAGE(Net Plot Area)	(A-Deductions)	111.15
Plot Area for FAR (Net Plot Area + RoadWidening Area)	(A-Deductions)	111.15
COVERAGE CHECK		
Permissible Coverage area ( 70.00 % )		77.81
Proposed Coverage Area ( 63.26 % )		70.31
Total Prop. Coverage Area ( 63.26 % )		70.31
Balance coverage area ( 6.75 % )		7.50
FAR CHECK		
Perm. FAR Area ( 2.50 )		277.88
Total Perm. FAR area		277.88
Residential FAR		140.62
Proposed FAR Area		154.11
Total Proposed FAR Area		154.11
Consumed FAR (Factor)		1.39
Balance FAR Area		123.77
BUILT UP AREA CHECK		
Total Proposed BuiltUp Area		210.93
ARCHITECT (Regd)	L K Suman	
ENGINEER (Regd)		
SUPERVISOR (Regd)		
OWNER (Regd)	TUHINA BANERJEE & PROVAS MUKHERJEE	
DEVELOPMENT AUTHORITY		LOCAL BODY

COLOR INDEX	
PLOT BOUNDARY	Black
ABUTTING ROAD	Green
PROPOSED CONSTRUCTION	Red
COMMON PLOT	Yellow
ROAD WIDENING AREA	Blue
EXISTING (To be retained)	Light Blue
EXISTING (To be demolished)	Light Yellow

Buildingwise Floor FAR Details

Floor Name	Building Name A (TUHINA BANERJEE AND PROVAS MUKHERJEE)		Total	
	Proposed Built Up Area (Sq.mt.)	Proposed FAR Area (Sq.mt.)	Total Proposed Built Up Area (Sq.mt.)	Total FAR Area (Sq.mt.)
Parking Floor	70.31	13.49	70.31	13.49
First Floor	70.31	70.31	70.31	70.31
Second Floor	70.31	70.31	70.31	70.31
Terrace Floor	0.00	0.00	0.00	0.00
Total	210.93	154.11	210.93	154.11

Building USE/SUBUSE Details

Building Name	Building Use	Building SubUse	Building Structure
A (TUHINA BANERJEE AND PROVAS MUKHERJEE)	Residential	Bungalow/ Dwelling / Non Apartment	Non-Highrise

LTP NAME AND SIGNATURE	STRUCTURAL ENG'S NAME AND SIGNATURE	BUILDER NAME AND SIGNATURE	DIGITAL SIGNATURE
L K Suman JNAC/ENG/0006/2016			

Proposal Basic Information	
Proposal File No.	JNAC/BP/0047/W11/2021
Owner Name	TUHINA BANERJEE & PROVAS MUKHERJEE
Khata No	Nil
Plot No	H. No.-293 Sitaramdera Radio Maidan
Village Name	Sitaramdera
Use	Residential
SubUse	Bungalow/ Dwelling / Non Apartment

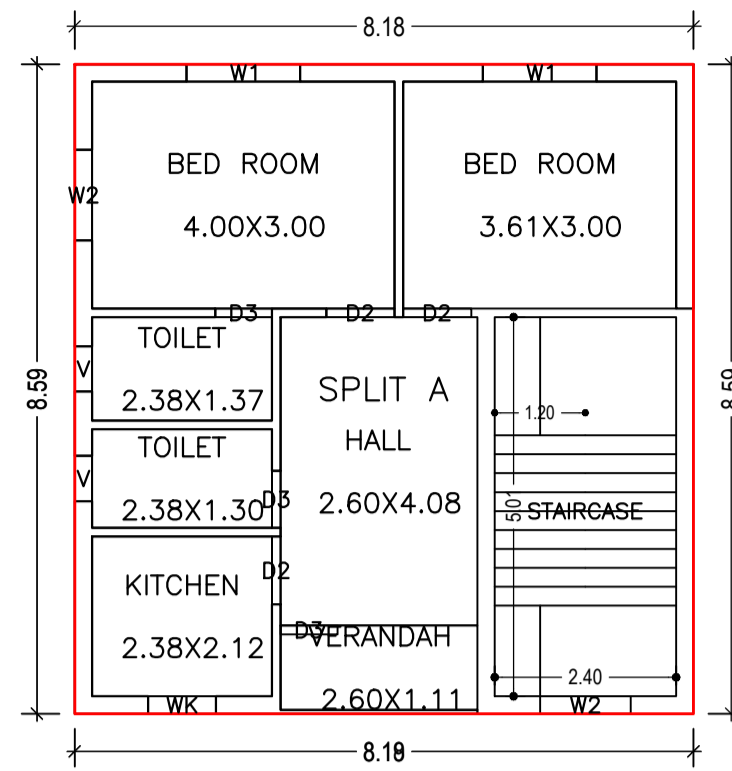
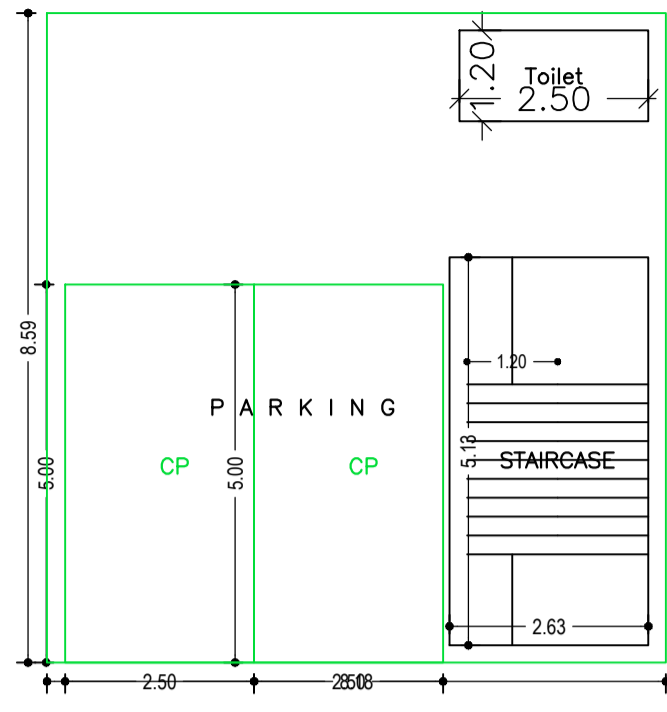

SECOND FLOOR PLAN (Proposed) (SCALE 1:100)

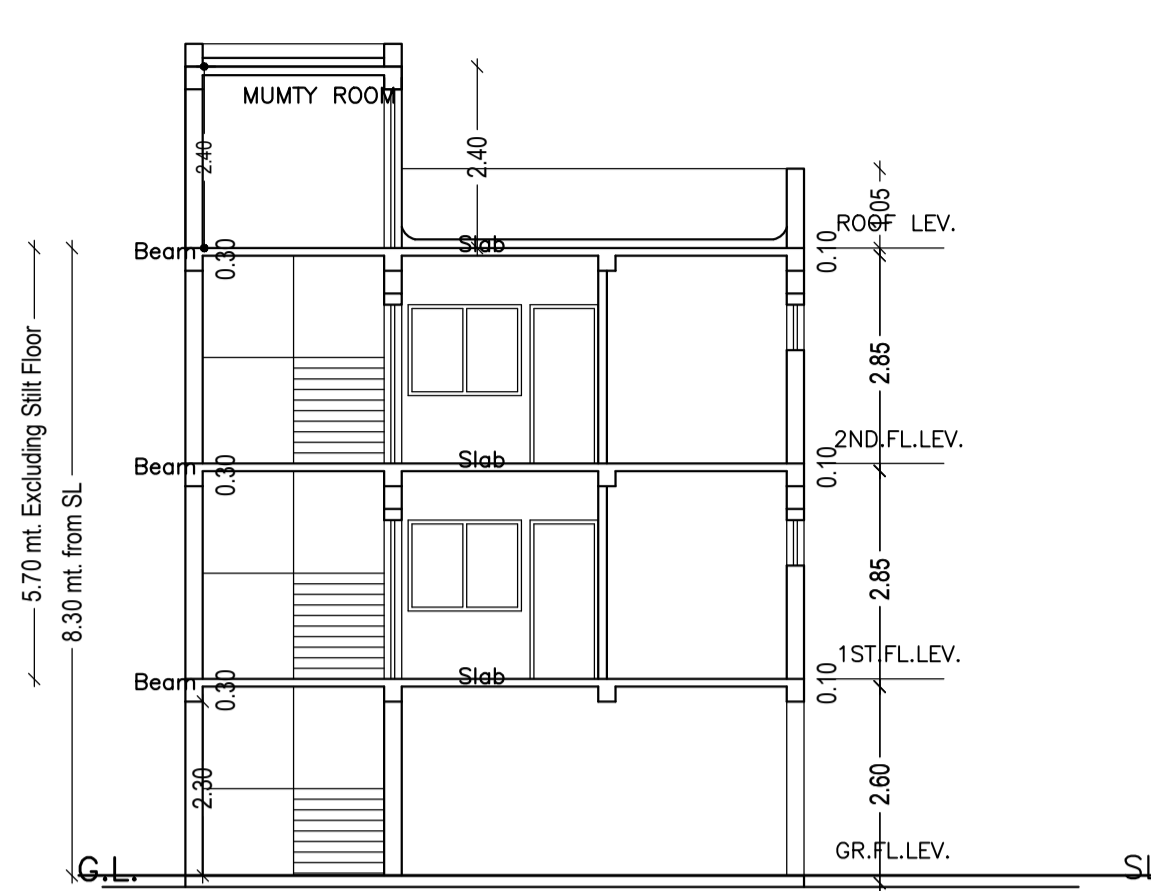

SCALE=1:100

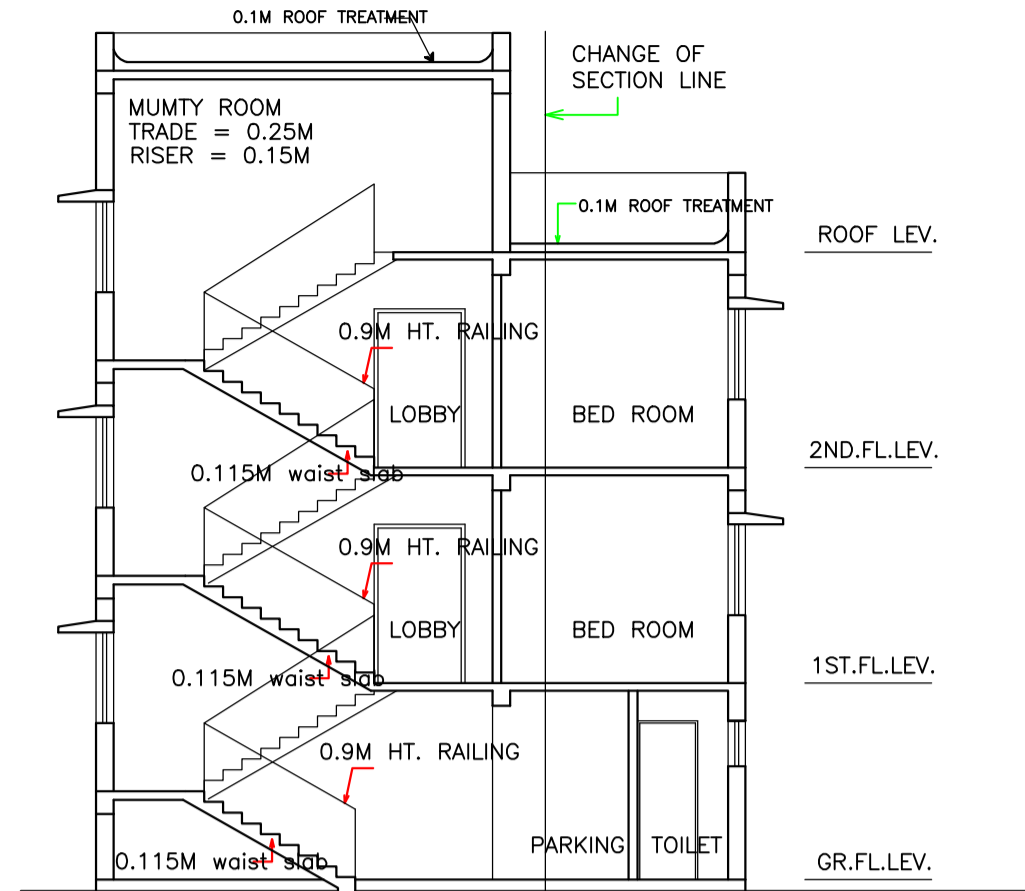

SECTION - Y-Y (SCALE 1:100)

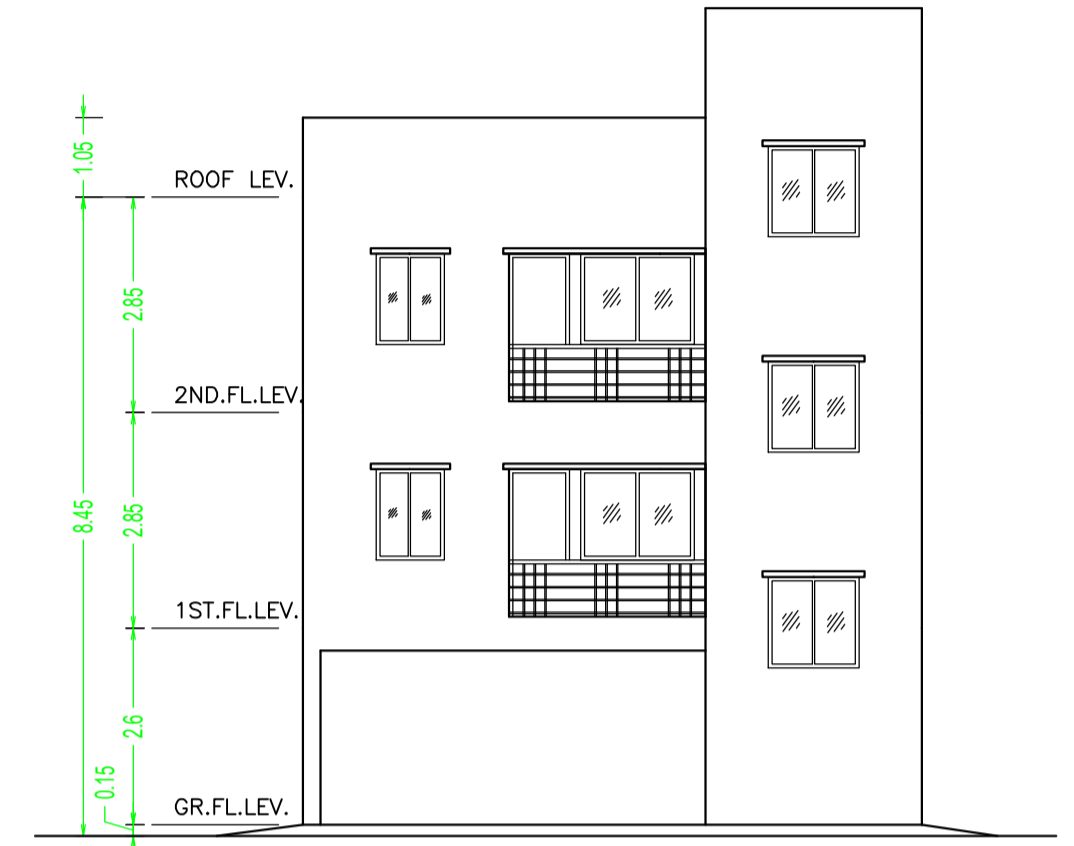

FRONT ELEVATION (SCALE 1:100)

PARKING FLOOR PLAN (SCALE 1:100)

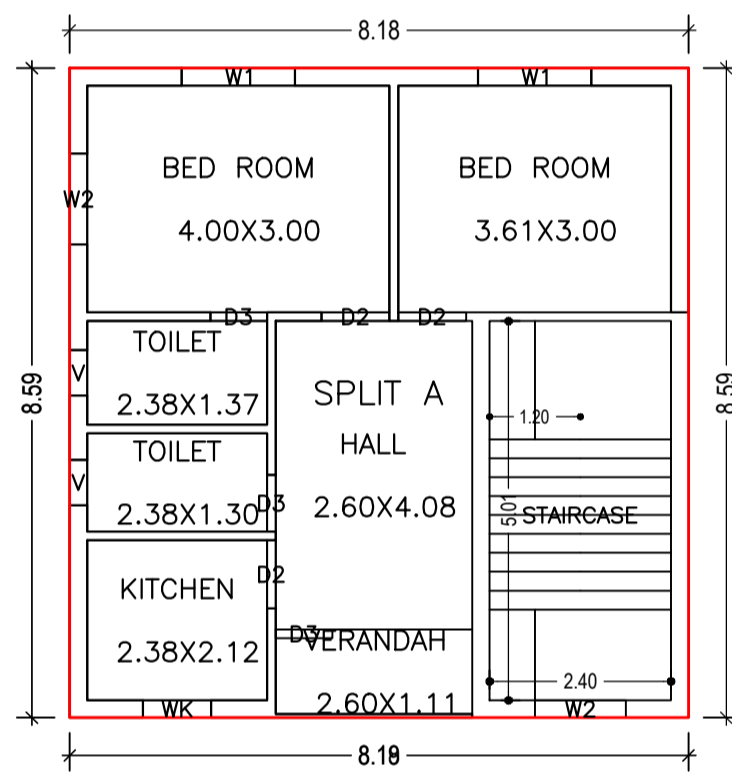

FIRST FLOOR PLAN (Proposed) (SCALE 1:100)

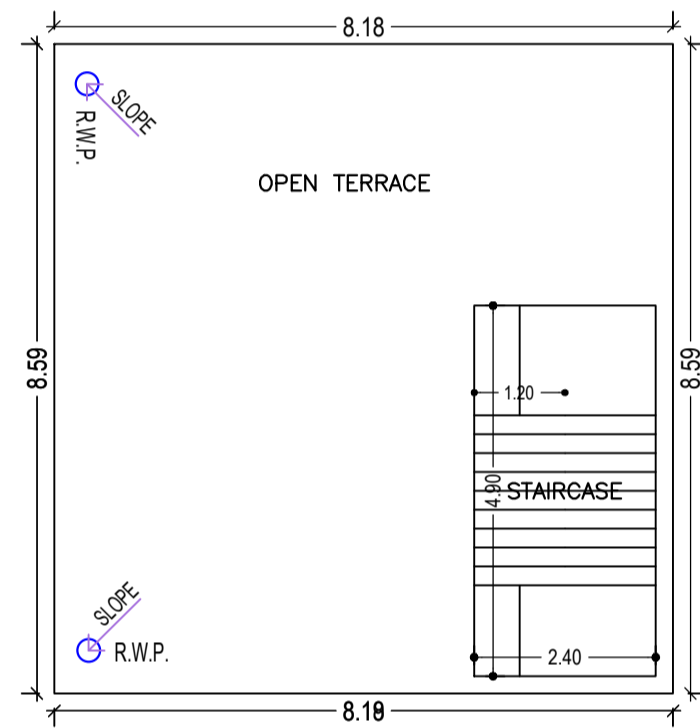

TERRACE FLOOR PLAN (SCALE 1:100)

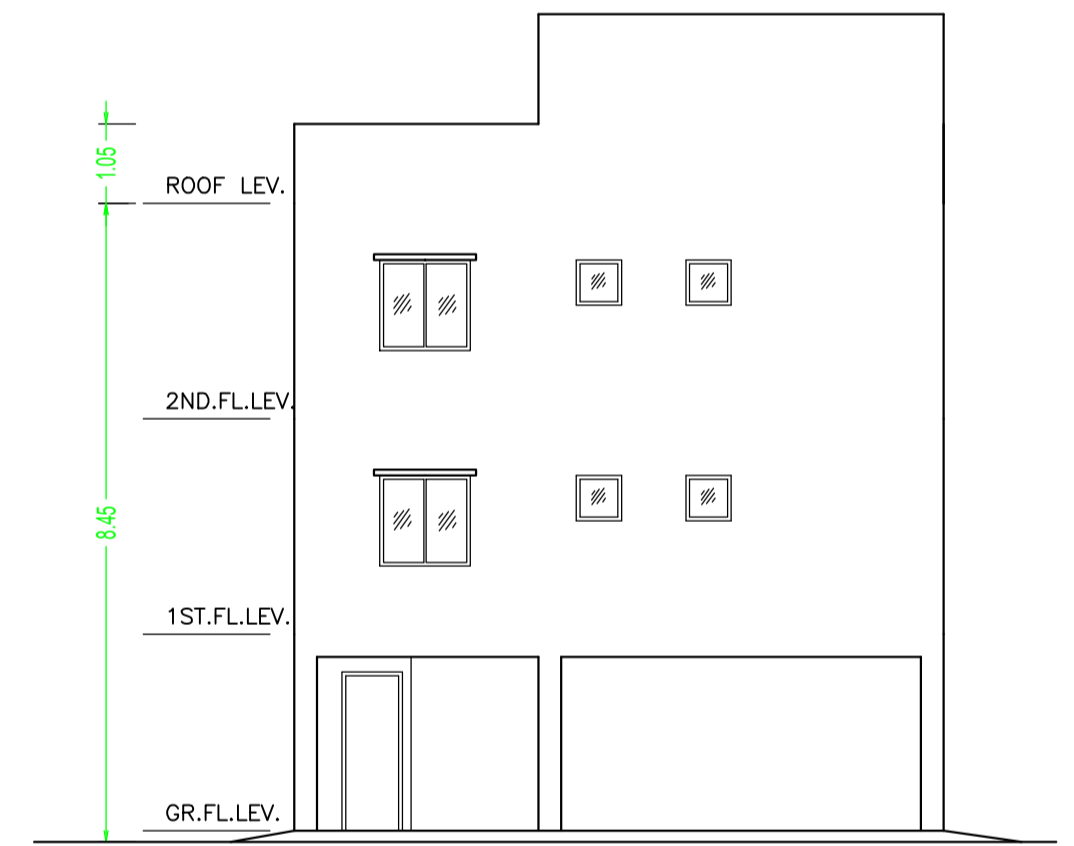

SIDE - A ELEVATION (SCALE 1:100)



SCALE : NTS

SCHEDULE OF DOOR:

BUILDING NAME	NAME	LENGTH	HEIGHT	NOS
A (TUHINA BANERJEE AND PROVAS MUKHERJEE)	D3	0.75	2.10	06
A (TUHINA BANERJEE AND PROVAS MUKHERJEE)	D2	0.90	2.10	06

SCHEDULE OF WINDOW/VENTILATION:

BUILDING NAME	NAME	LENGTH	HEIGHT	NOS
A (TUHINA BANERJEE AND PROVAS MUKHERJEE)	V	0.60	0.60	04
A (TUHINA BANERJEE AND PROVAS MUKHERJEE)	WK	0.90	1.20	02
A (TUHINA BANERJEE AND PROVAS MUKHERJEE)	W2	1.20	1.20	04
A (TUHINA BANERJEE AND PROVAS MUKHERJEE)	W1	1.50	1.20	04

UnitBUA Table for Building :A (TUHINA BANERJEE AND PROVAS MUKHERJEE)

FLOOR	Name	UnitBUA Type	UnitBUA Area	Carpet Area	No. of Rooms	No. of Tenement
FIRST FLOOR PLAN	SPLIT A	FLAT	140.62	129.99	7	1
SECOND FLOOR PLAN	SPLIT A	FLAT	0.00	0.00	7	0
Total:	-	-	140.62	129.99	14	1

Building :A (TUHINA BANERJEE AND PROVAS MUKHERJEE)

Floor Name	Total Built Up Area (Sq.mt.)	Deductions (Area in Sq.mt.)		Proposed FAR Area (Sq.mt.)	Add Area In FAR (Sq.mt.)	Total FAR Area (Sq.mt.)	Total Consumed Additional FAR Area (Sq.mt.)	Trmt (No.)
		Accessory Use	Parking					
Parking Floor	70.31	3.00	53.82	0.00	13.49	13.49	13.49	00
First Floor	70.31	0.00	0.00	70.31	0.00	70.31	70.31	01
Second Floor	70.31	0.00	0.00	70.31	0.00	70.31	70.31	00
Terrace Floor	0.00	0.00	0.00	0.00	0.00	0.00	0.00	00
Total :	210.93	3.00	53.82	140.62	13.49	154.11	154.11	01
Total Number of Same Buildings	1							
Total :	210.93	3.00	53.82	140.62	13.49	154.11	154.11	01

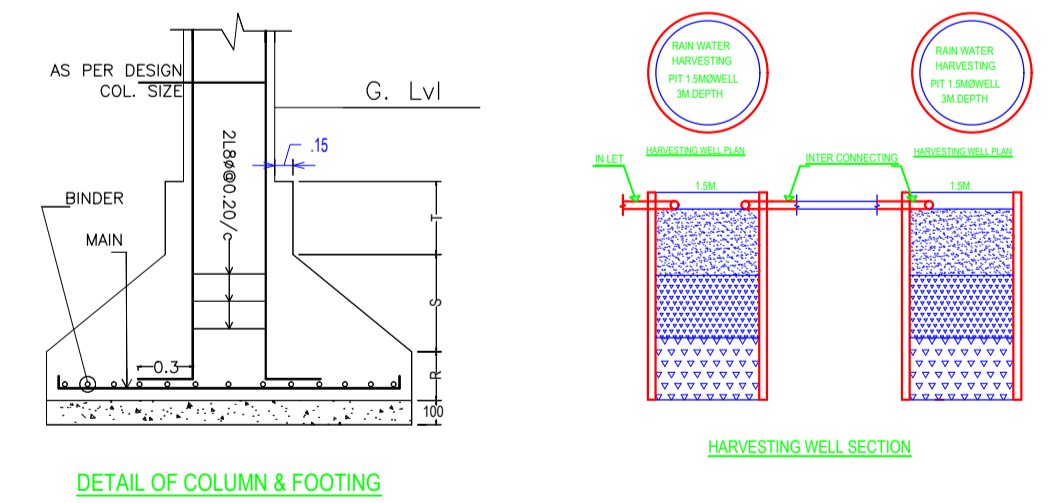

DETAIL OF COLUMN & FOOTING

HARVESTING WELL SECTION

LTP NAME AND SIGNATURE	STRUCTURAL ENG'S NAME AND SIGNATURE	BUILDER NAME AND SIGNATURE	DIGITAL SIGNATURE
L K Suman JNAC/ENG/0006/2016			