

SITE PLAN
SCALE=1:100
SITE PLAN

FAR & Tenement Details (Table 4c-1)

Building	No. of Same Bldg	Total Built Up Area (Sq.mt.)	Proposed FAR Area (Sq.mt.)		Total FAR Area (Sq.mt.)	Total Consumed Additional FAR Area (Sq.mt.)	Tenmt (No.)
			Resi.	Stair			
A (N R NARAYAN)	1	154.38	143.22	11.16	154.38	154.38	01
Grand Total :	1	154.38	143.22	11.16	154.38	154.38	01

Proposal Basic Information

Proposal File No.	JNAC/BP/0115/W2/2021
Owner Name	N.R NARAYAN
Khata No	NIL
Plot No	E/164
Village Name	SONARI
Use	Residential
SubUse	Row House

AREA STATEMENT JAMSHEDPUR NAC	VERSION NO.: 1.0.62 VERSION DATE: 16/10/2020	
PROJECT DETAIL:		
Region: JHARKHAND URBAN LOCAL BODIES	Plot Use: Residential	
District: EAST SINGHBHUM	Plot SubUse: Row House	
Authority: JAMSHEDPUR NAC	PlotNearby/ReligiousStructure: NA	
Inward_No: JNAC/BP/0115/W2/2021	PlotSubPlot No: E/164	
Application Type: General Proposal	North: Plot No. - E/163	
Project Type: Building Permission	South: Plot No. - VACCANT LAND	
Nature of Development: New	East: Road Width - 6.10 M	
Location of Development Area: Old Area	West: Road Width - 4.5 M	
AREA DETAILS:		
AREA OF PLOT (Minimum)	(A)	SQ.MT. 111.42
NET AREA OF PLOT(Gross Plot Area - Deduction from Gross Plot area)	(A-Deductions)	111.42
Deduction for Balance Plot Area(from Gross Plot Area)		
Common Plot		9.91
Total		9.91
BALANCE AREA OF PLOT(Net Plot Area - Recreational/Amenity space)	(A-Deductions)	101.50
PLOT AREA FOR COVERAGE(Net Plot Area)	(A-Deductions)	111.42
Plot Area for FAR (Net Plot Area + RoadWidening Area)	(A-Deductions)	111.42
COVERAGE CHECK		
Permissible Coverage area (70.00 %)		77.99
Proposed Coverage Area (64.27 %)		71.61
Total Prop. Coverage Area (64.27 %)		71.61
Balance coverage area (5.73 %)		6.38
FAR CHECK		
Perm. FAR Area (2.50)		278.55
Total Perm. FAR area		278.55
Residential FAR		143.21
Proposed FAR Area		154.37
Total Proposed FAR Area		154.37
Consumed FAR (Factor)		1.39
Balance FAR Area		124.18
BUILT UP AREA CHECK		
Total Proposed BuiltUp Area		154.38
ARCHITECT (Regd)	SHREYASHI PAUL	
ENGINEER (Regd)		
SUPERVISOR (Regd)		
OWNER (Regd)	N.R NARAYAN	
DEVELOPMENT AUTHORITY	LOCAL BODY	

COLOR INDEX	
PLOT BOUNDARY	Black
ABUTTING ROAD	Green
PROPOSED CONSTRUCTION	Red
COMMON PLOT	Yellow
ROAD WIDENING AREA	Blue
EXISTING (To be retained)	Blue
EXISTING (To be demolished)	Yellow

Buildingwise Floor FAR Details

Floor Name	Building Name A (N R NARAYAN)		Total	
	Proposed Built Up Area (Sq.mt.)	Proposed FAR Area (Sq.mt.)	Total Proposed Built Up Area (Sq.mt.)	Total FAR Area (Sq.mt.)
Parking Floor	11.16	11.16	11.16	11.16
First Floor	71.61	71.61	71.61	71.61
Second Floor	71.61	71.61	71.61	71.61
Terrace Floor	0.00	0.00	0.00	0.00
Total :	154.38	154.38	154.38	154.38

Building USE/SUBUSE Details

Building Name	Building Use	Building SubUse	Building Structure
A (N R NARAYAN)	Residential	Semidetached	Non-Highrise

LTP NAME AND SIGNATURE	STRUCTURAL ENG'S NAME AND SIGNATURE	BUILDER NAME AND SIGNATURE	DIGITAL SIGNATURE
SHREYASHI PAUL JNAC/DFTMN/0009/2016			

Proposal Basic Information	
Proposal File No.	JNAC/BP/0115/W2/2021
Owner Name	N.R NARAYAN
Khata No	NIL
Plot No	E/164
Village Name	SONARI
Use	Residential
SubUse	Row House

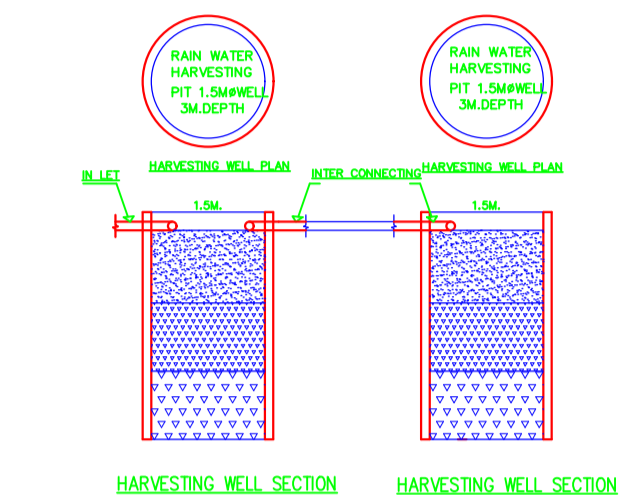
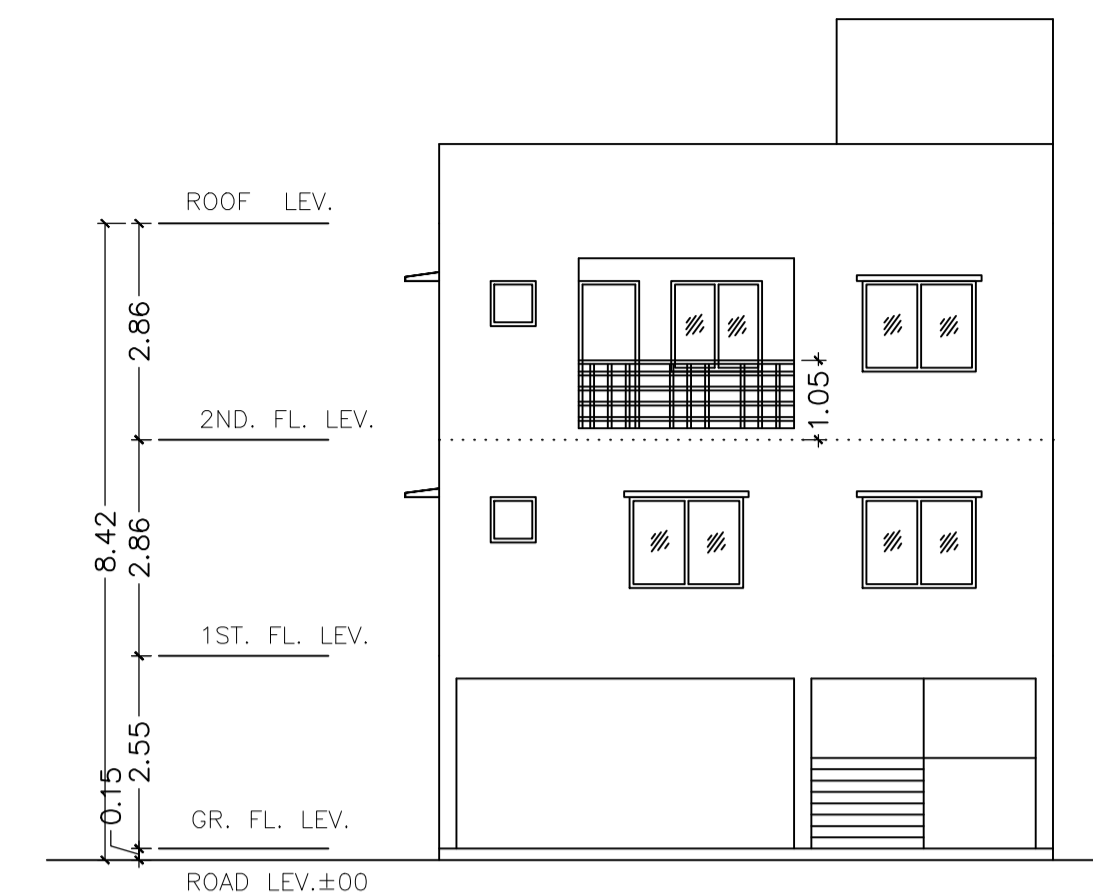
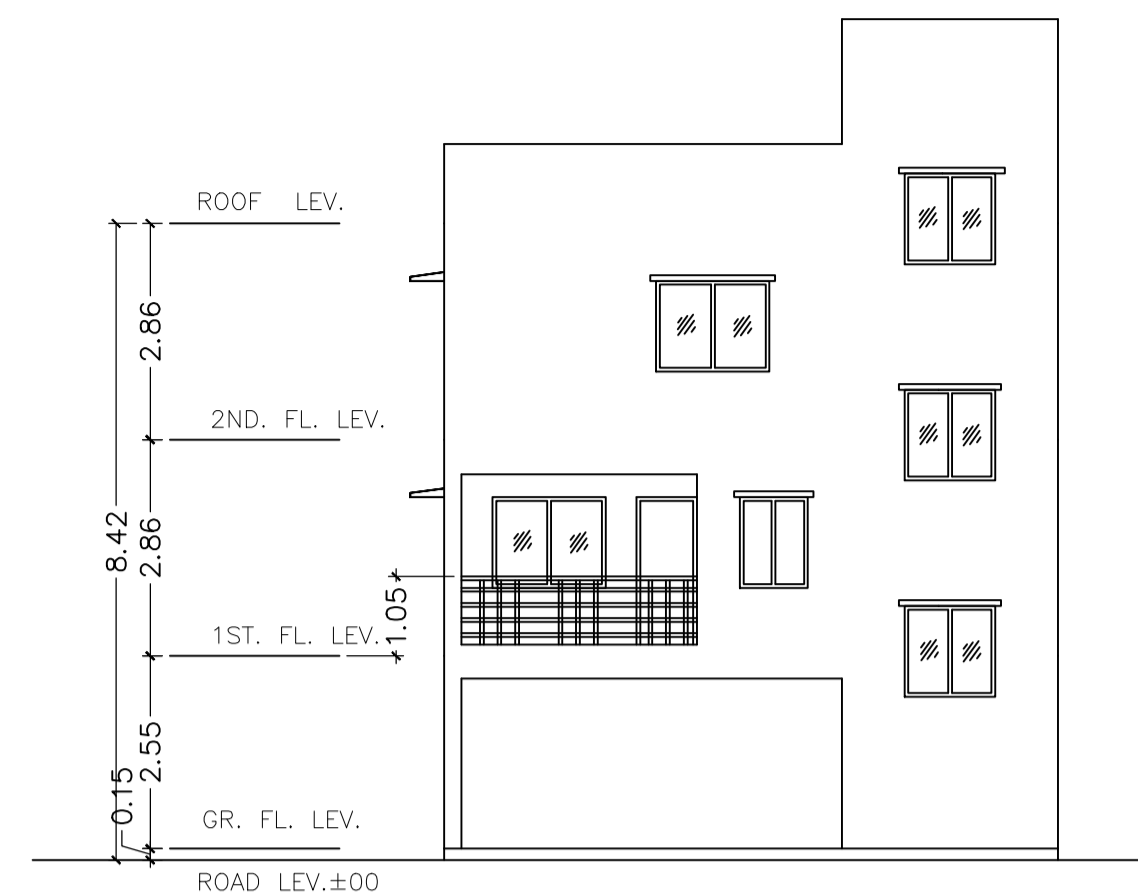
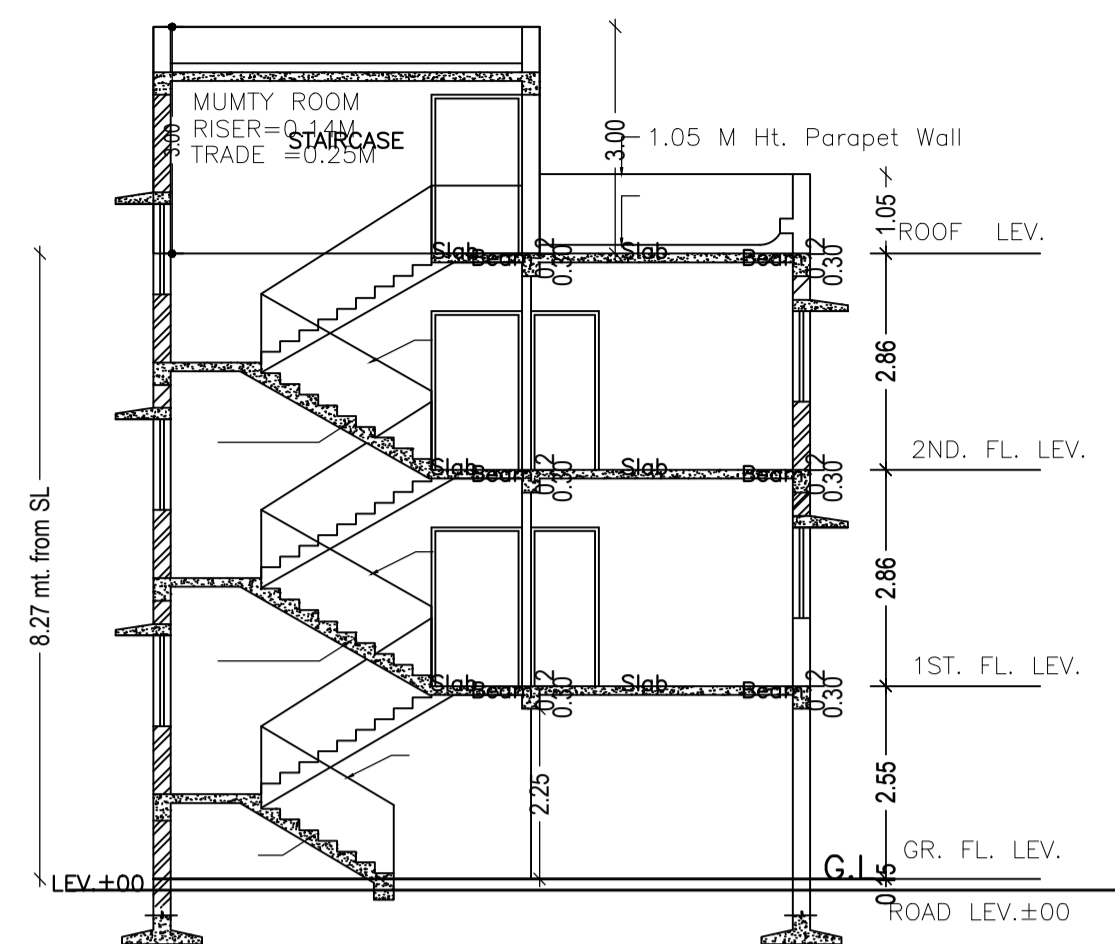
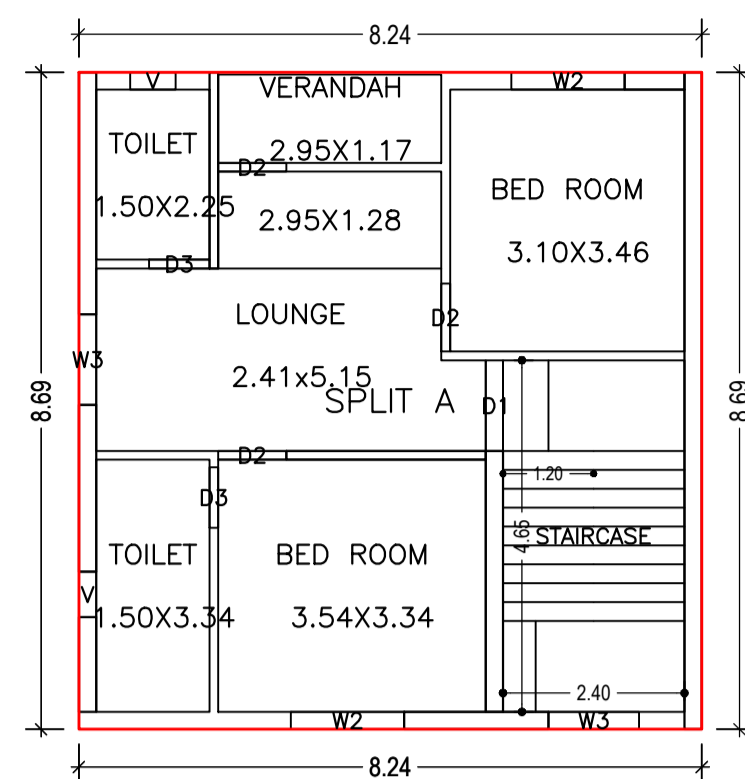
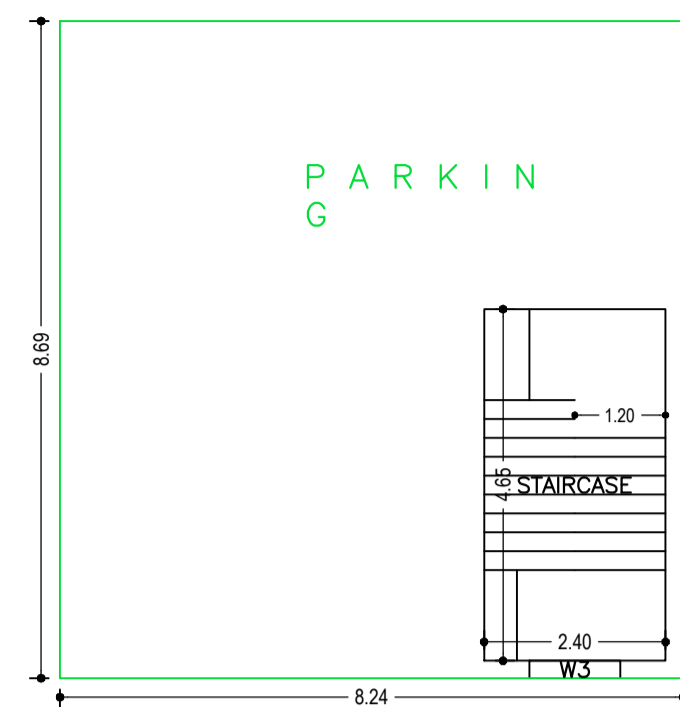

PARKING FLOOR PLAN (SCALE 1:100)

SECOND FLOOR PLAN (Proposed) (SCALE 1:100)

SECTION - Y-Y (SCALE=1:100)

FRONT ELEVATION (SCALE=1:100)

RARE SIDE ELEVATION (SCALE=1:100)

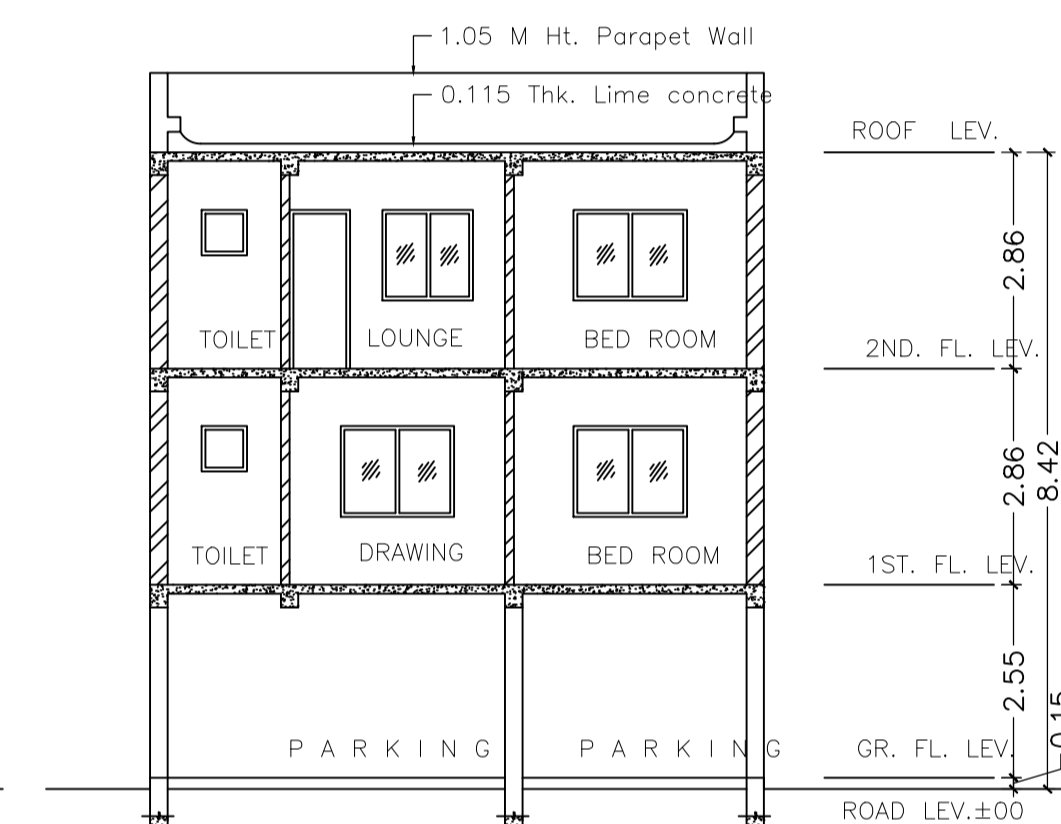
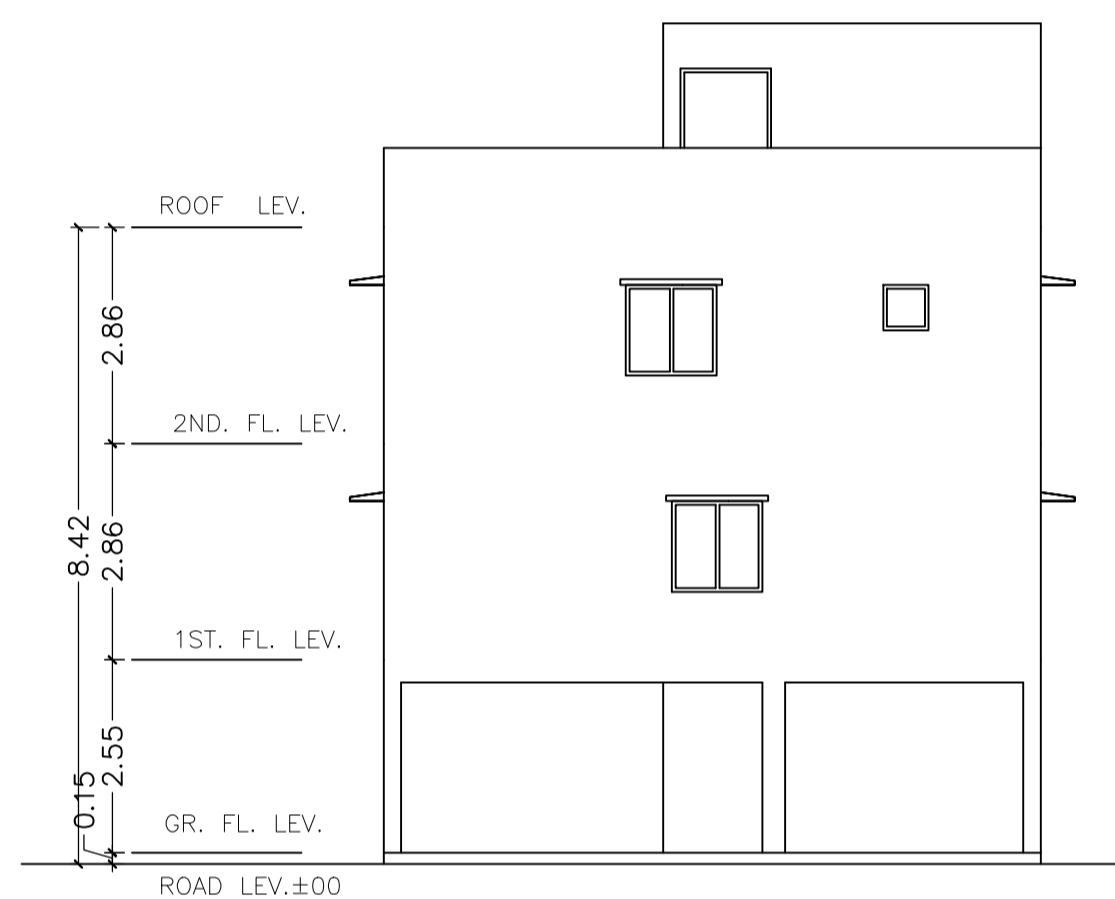
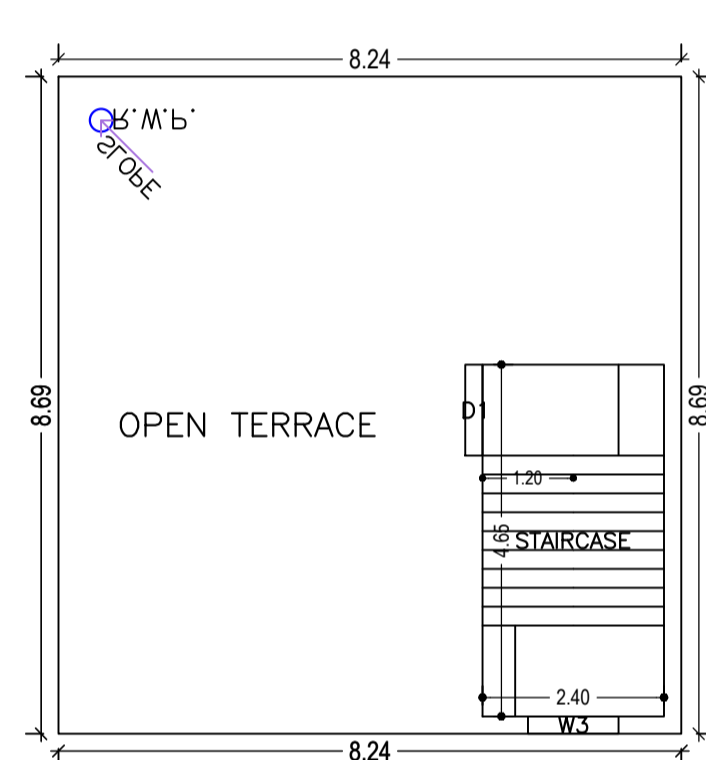
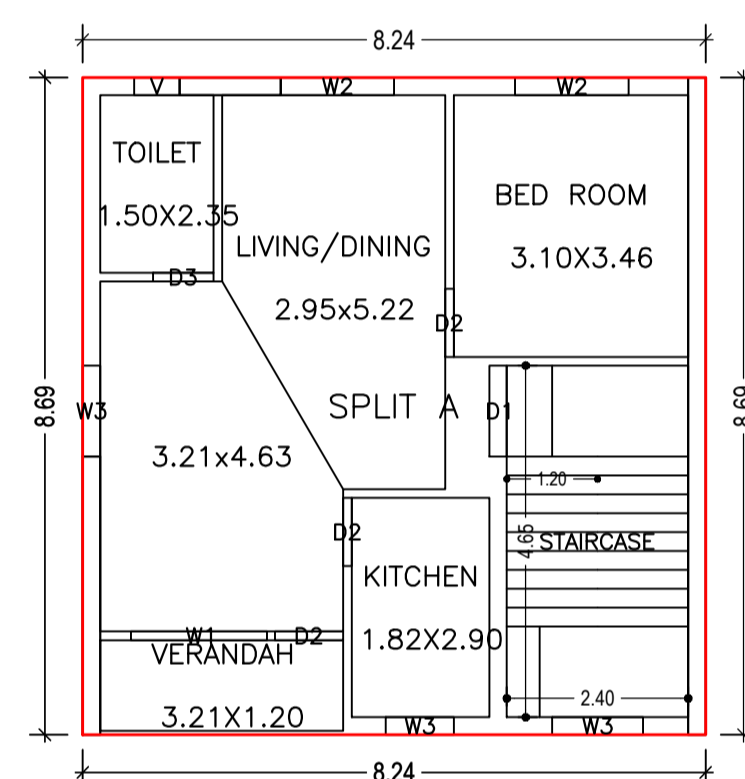

SIDE - A ELEVATION (SCALE=1:100)

SECTION - X-X (SCALE=1:100)

FIRST FLOOR PLAN (Proposed) (SCALE 1:100)

TERRACE FLOOR PLAN (Proposed) (SCALE 1:100)

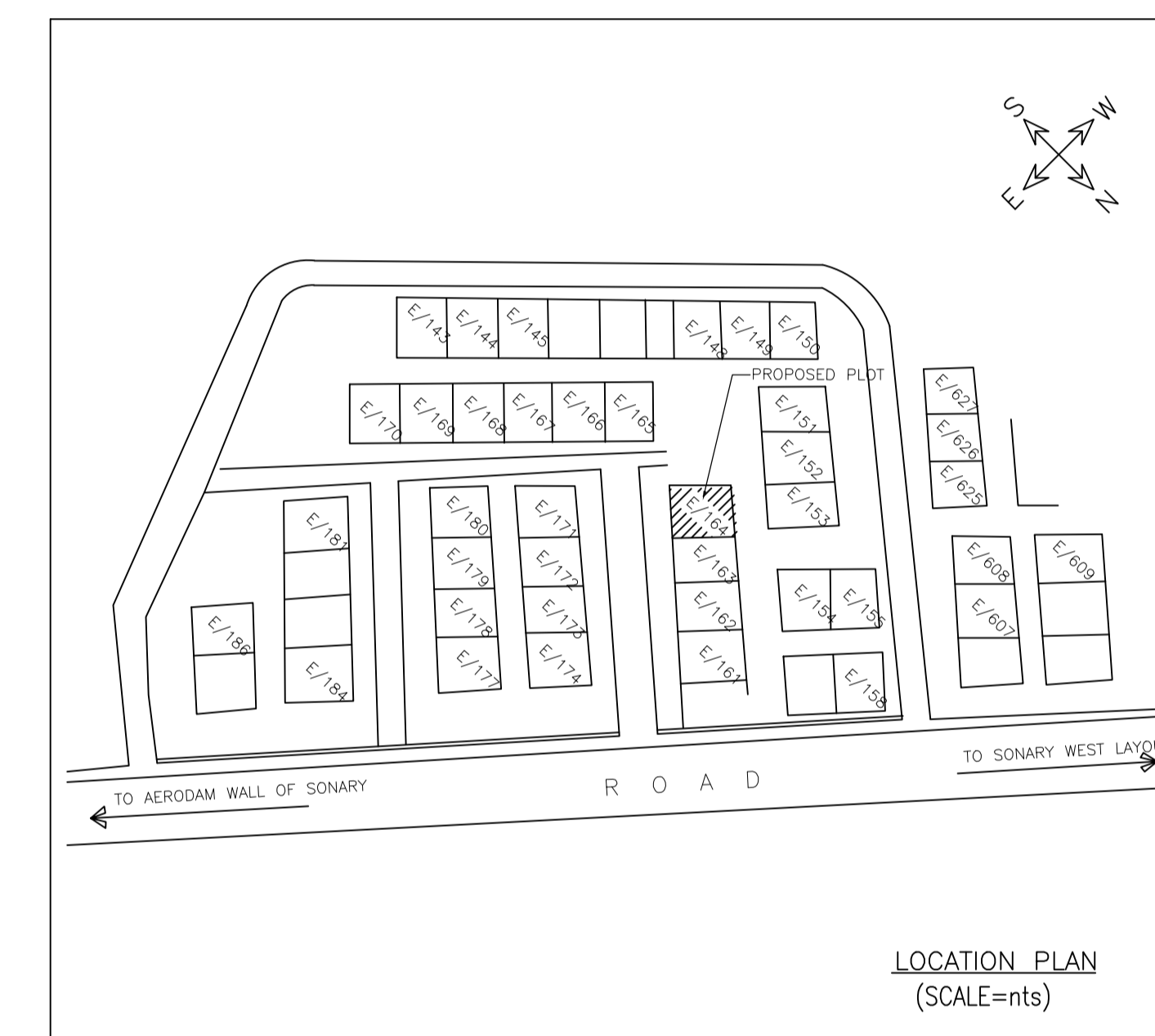

LOCATION PLAN (SCALE=nts)

Building :A (N R NARAYAN)

Floor Name	Total Built Up Area (Sq.mt.)	Proposed FAR Area (Sq.mt.)	Add Area in FAR (Sq.mt.)	Total FAR Area (Sq.mt.)	Total Consumed Additional FAR Area (Sq.mt.)	Tnmt (No.)
Parking Floor	11.16	0.00	11.16	11.16	11.16	00
First Floor	71.61	71.61	0.00	71.61	71.61	01
Second Floor	71.61	71.61	0.00	71.61	71.61	00
Terrace Floor	0.00	0.00	0.00	0.00	0.00	00
Total :	154.38	143.22	11.16	154.38	154.38	01
Total Number of Same Buildings	1					
Total :	154.38	143.22	11.16	154.38	154.38	01

SCHEDULE OF DOOR:

BUILDING NAME	NAME	LENGTH	HEIGHT	NOS
A (N R NARAYAN)	D3	0.80	2.10	03
A (N R NARAYAN)	D2	0.90	2.10	06
A (N R NARAYAN)	D1	1.20	2.10	01

SCHEDULE OF WINDOW/VENTILATION:

BUILDING NAME	NAME	LENGTH	HEIGHT	NOS
A (N R NARAYAN)	V	0.60	0.60	03
A (N R NARAYAN)	W3	0.90	1.20	01
A (N R NARAYAN)	W3	1.20	1.20	06
A (N R NARAYAN)	W2	1.50	1.20	04
A (N R NARAYAN)	W1	1.80	1.20	01

UnitBUA Table for Building :A (N R NARAYAN)

FLOOR	Name	UnitBUA Type	UnitBUA Area	Carpet Area	No. of Rooms	No. of Tenement
FIRST FLOOR PLAN	SPLIT A	FLAT	143.21	134.51	5	1
SECOND FLOOR PLAN	SPLIT A	FLAT	0.00	0.00	6	0
Total:	-	-	143.21	134.51	11	1

LTP NAME AND SIGNATURE	STRUCTURAL ENG'S NAME AND SIGNATURE	BUILDER NAME AND SIGNATURE	DIGITAL SIGNATURE
SHREYASHI PAUL JNAC/DFTMN/0009/2016			

Proposal Basic Information	
Proposal File No.	JNAC/BP/0115/W2/2021
Owner Name	N.R NARAYAN
Khata No	NIL
Plot No	E/164
Village Name	SONARI
Use	Residential
SubUse	Row House

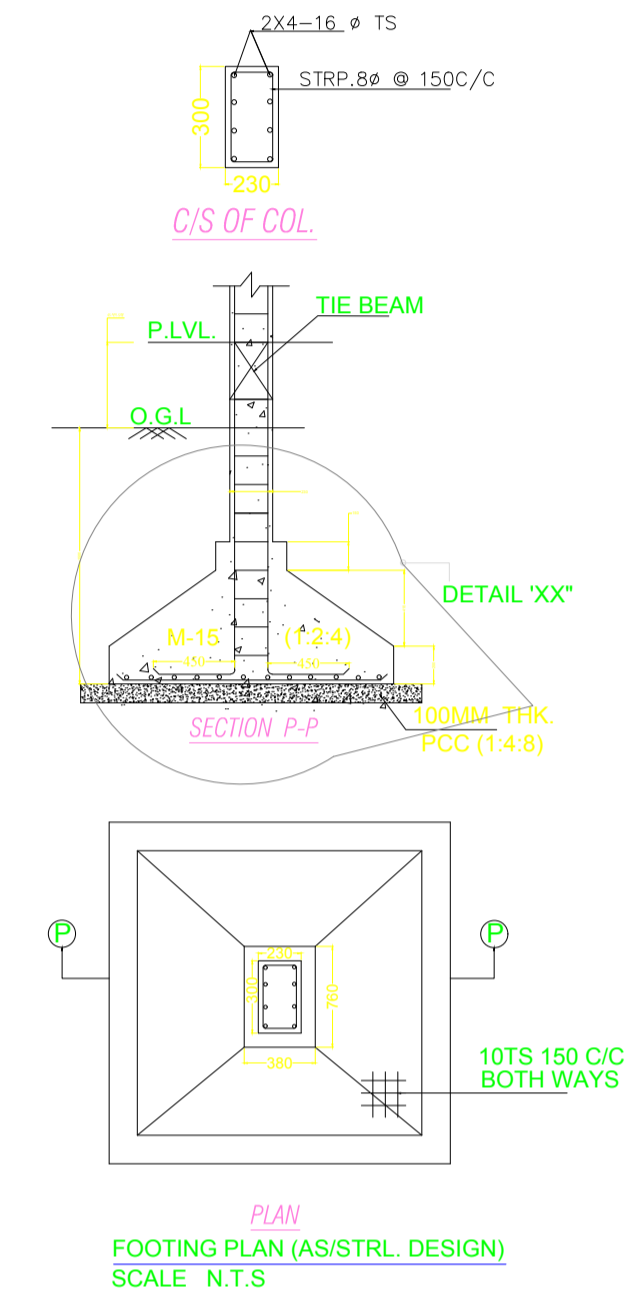

LTP NAME AND SIGNATURE	STRUCTURAL ENG'S NAME AND SIGNATURE	BUILDER NAME AND SIGNATURE	DIGITAL SIGNATURE
SHREYASHI PAUL JNAC/DFTMN/0009/2016			