

SITE PLAN

FAR & Tenement Details (Table 4c-1)

Building	No. of Same Bldg	Total Built Up Area (Sq.mt.)	Deductions (Area in Sq.mt.)		Proposed FAR Area (Sq.mt.)	Add Area In FAR (Sq.mt.)	Total FAR Area (Sq.mt.)	Total Consumed Additional FAR Area (Sq.mt.)	Tnmt (No.)
			Parking	Resi.					
A (KAILASH AGARWAL AND OTHERS)	1	214.50	62.46	143.00	9.04	152.04	152.04	01	
Grand Total :	1	214.50	62.46	143.00	9.04	152.04	152.04	01	

Proposal Basic Information

Proposal File No.	JNAC/PI/0088/W7/2021
Owner Name	KAILASH AGARWAL AND OTHERS
Khata No	190 TATA LEASE
Plot No	190 TATA LEASE
Village Name	Sitaramdera
Use	Residential
SubUse	Bungalow/ Dwelling / Non Apartment

AREA STATEMENT JAMSHEDPUR NAC	VERSION NO.: 1.0.61	VERSION DATE: 16/10/2020
PROJECT DETAIL:		
Region: JHARKHAND URBAN LOCAL BODIES	Plot Use: Residential	
District: EAST SINGHBHUM	Plot SubUse: Bungalow/ Dwelling / Non Apartment	
Authority: JAMSHEDPUR NAC	PlotNearby/ReligiousStructure: NA	
Inward_No.: JNAC/PI/0088/W7/2021	Plot/SubPlot No.: 190 TATA LEASE	
Application Type: General Proposal	North: Plot No. -	
Project Type: Building Permission	South: Road Width - 6.50	
Nature of Development: New	East: Plot No. -	
Location of Development Area: Old Area	West: Plot No. -	
AREA DETAILS:		
AREA OF PLOT (Minimum)	(A)	111.39
NET AREA OF PLOT (Gross Plot Area - Deduction from Gross Plot area)	(A-Deductions)	111.39
Deduction for Balance Plot Area(from Gross Plot Area)		
Common Plot		12.64
BALANCE AREA OF PLOT (Net Plot Area - Recreational/Amenity space)	(A-Deductions)	98.75
PLOT AREA FOR COVERAGE (Net Plot Area)	(A-Deductions)	111.39
Plot Area for FAR (Net Plot Area + Road Widening Area)	(A-Deductions)	111.39
COVERAGE CHECK		
Permissible Coverage area ( 70.00 % )		77.97
Proposed Coverage Area ( 64.19 % )		71.50
Total Prop. Coverage Area ( 64.19 % )		71.50
Balance coverage area ( 5.81 % )		6.47
FAR CHECK		
Perm. FAR Area ( 2.50 )		278.48
Total Perm. FAR area		278.48
Residential FAR		143.00
Proposed FAR Area		152.03
Total Proposed FAR Area		152.03
Consumed FAR (Factor)		
Balance FAR Area		126.45
BUILT UP AREA CHECK		
Total Proposed BuiltUp Area		214.50
ARCHITECT (Regd)	NIKHIL SHUKLA	
ENGINEER (Regd)		
SUPERVISOR (Regd)		
OWNER (Regd)	KAILASH AGARWAL AND OTHERS	
DEVELOPMENT AUTHORITY		LOCAL BODY

COLOR INDEX	
PLOT BOUNDARY	Black
ABUTTING ROAD	Green
PROPOSED CONSTRUCTION	Red
COMMON PLOT	Yellow
ROAD WIDENING AREA	Blue
EXISTING (To be retained)	Light Blue
EXISTING (To be demolished)	Light Yellow

Buildingwise Floor FAR Details

Floor Name	Building Name		Total	
	Proposed Built Up Area (Sq.mt.)	Proposed FAR Area (Sq.mt.)	Total Proposed Built Up Area (Sq.mt.)	Total FAR Area (Sq.mt.)
Parking Floor	71.50	9.04	71.50	9.04
First Floor	71.50	71.50	71.50	71.50
Second Floor	71.50	71.50	71.50	71.50
Terrace Floor			0.00	0.00
Total :	214.50	152.04	214.50	152.04

Building USE/SUBUSE Details

Building Name	Building Use	Building SubUse	Building Structure
A (KAILASH AGARWAL AND OTHERS)	Residential	Bungalow/ Dwelling / Non Apartment	Non-Highrise

LTP NAME AND SIGNATURE	STRUCTURAL ENG'S NAME AND SIGNATURE	BUILDER NAME AND SIGNATURE	DIGITAL SIGNATURE
NIKHIL SHUKLA JNAC/ARC/0015/2019			

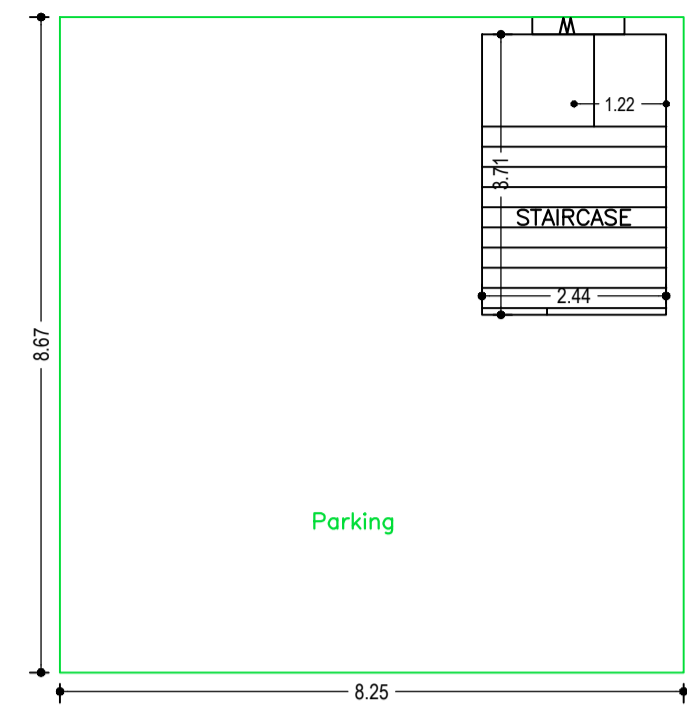

PARKING FLOOR PLAN (SCALE 1:100)

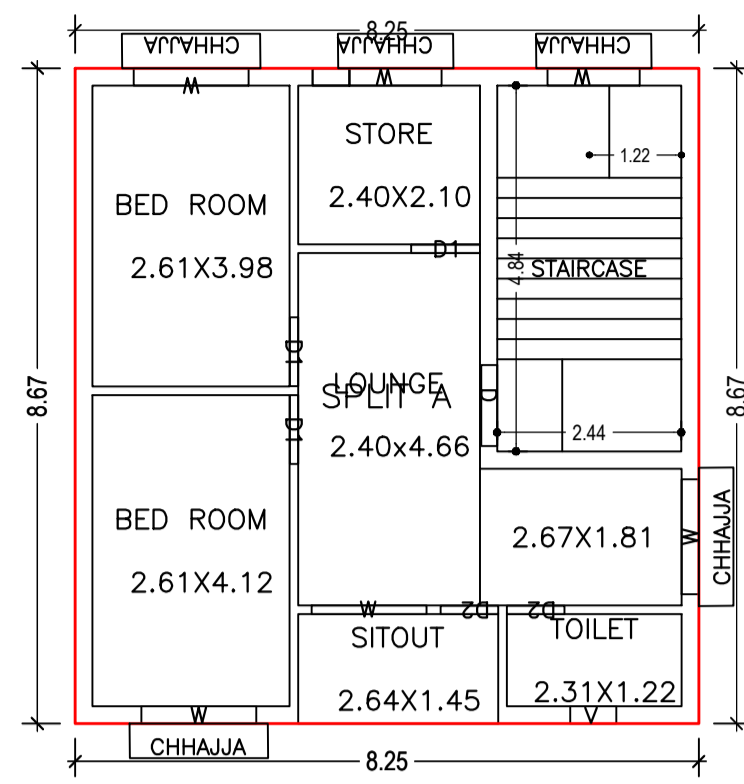

SECOND FLOOR PLAN (Proposed) (SCALE 1:100)

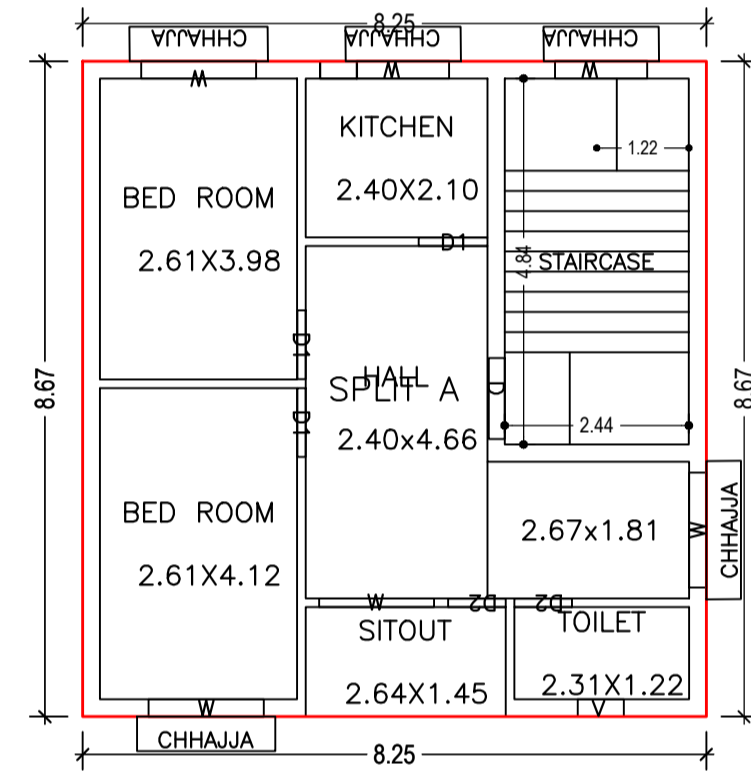

FIRST FLOOR PLAN (Proposed) (SCALE 1:100)

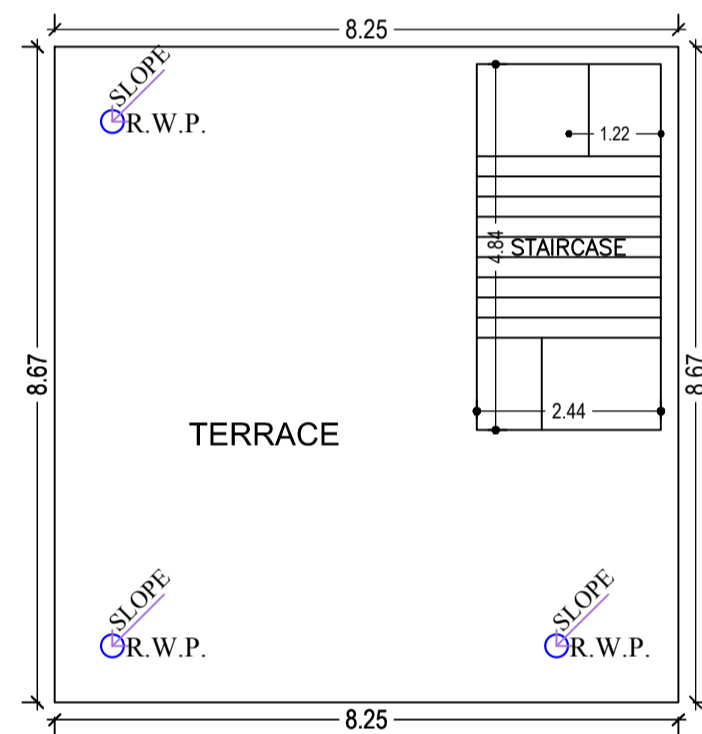

TERRACE FLOOR PLAN (SCALE 1:100)

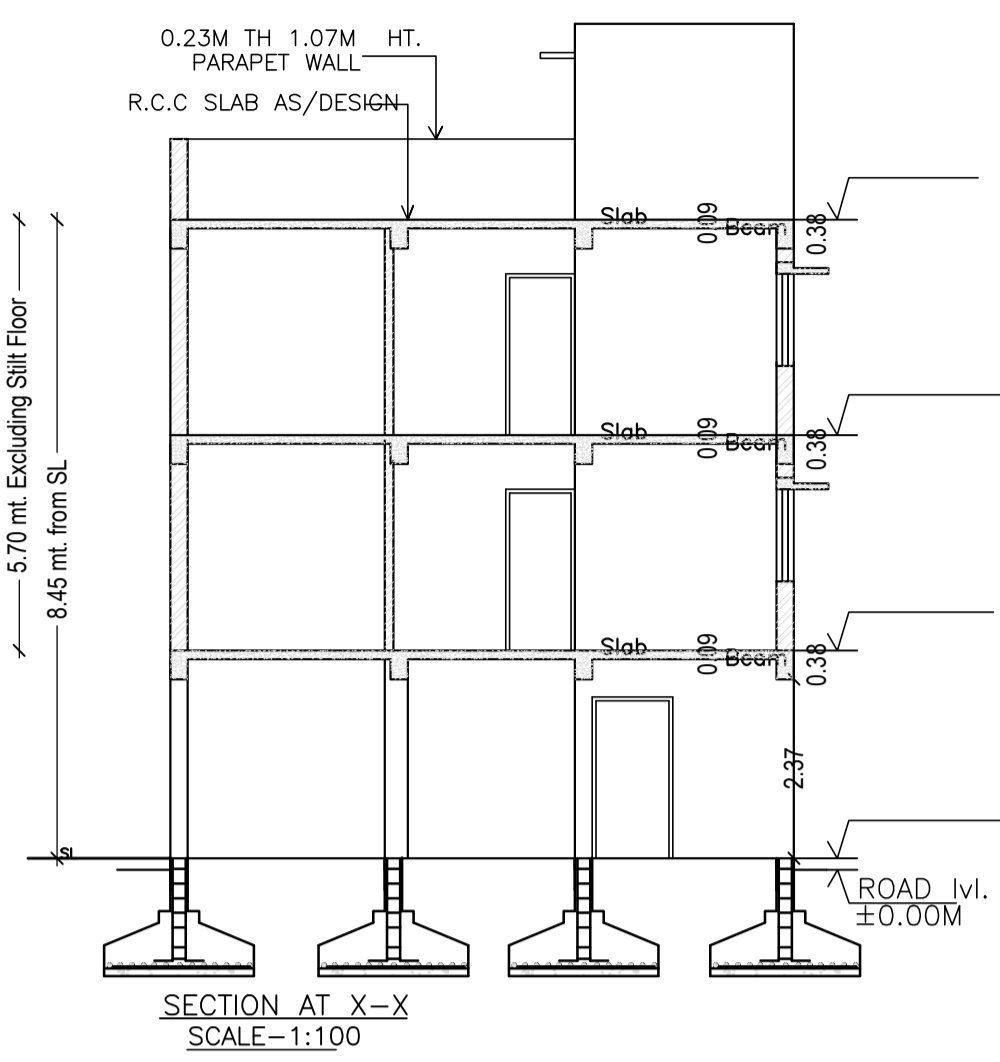

SECTION AT X-X (SCALE-1:100)

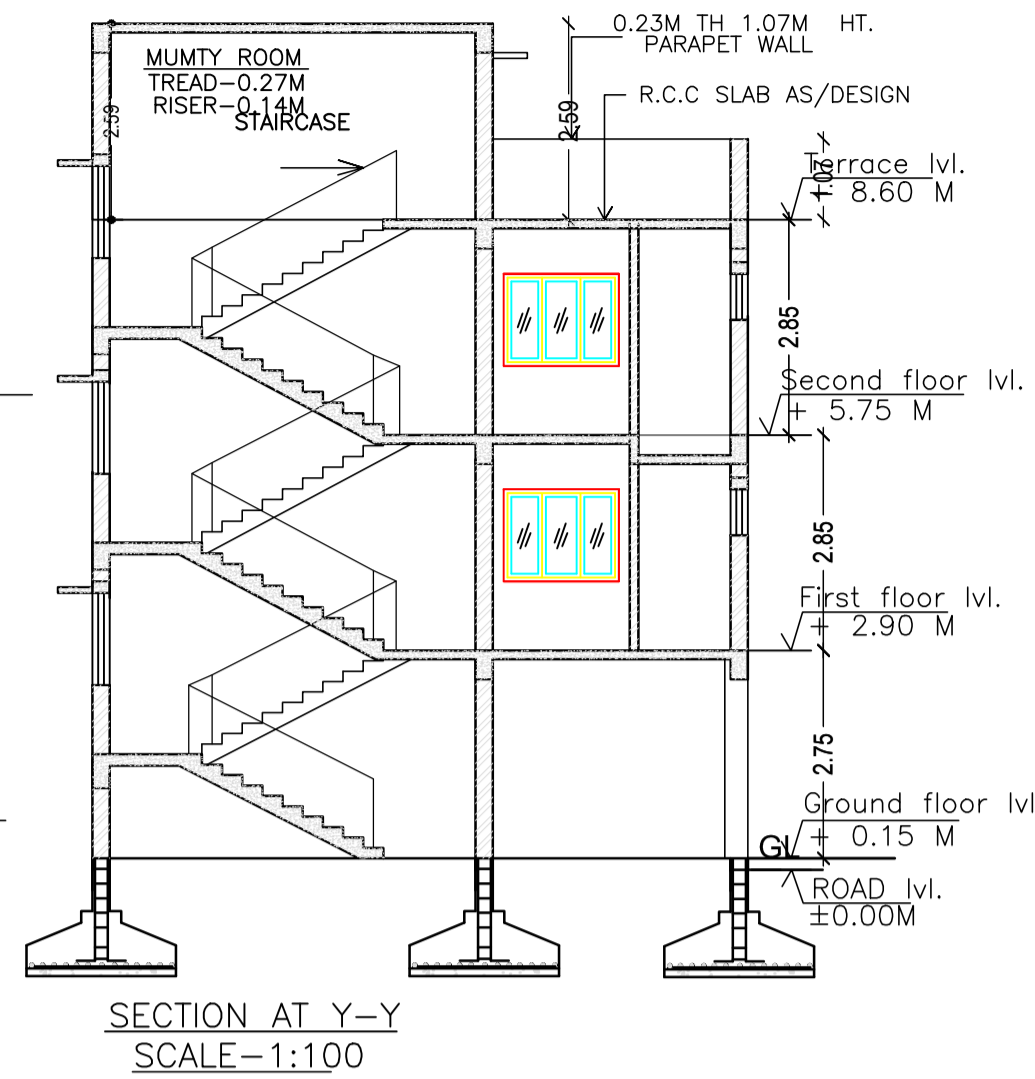

SECTION AT Y-Y (SCALE-1:100)

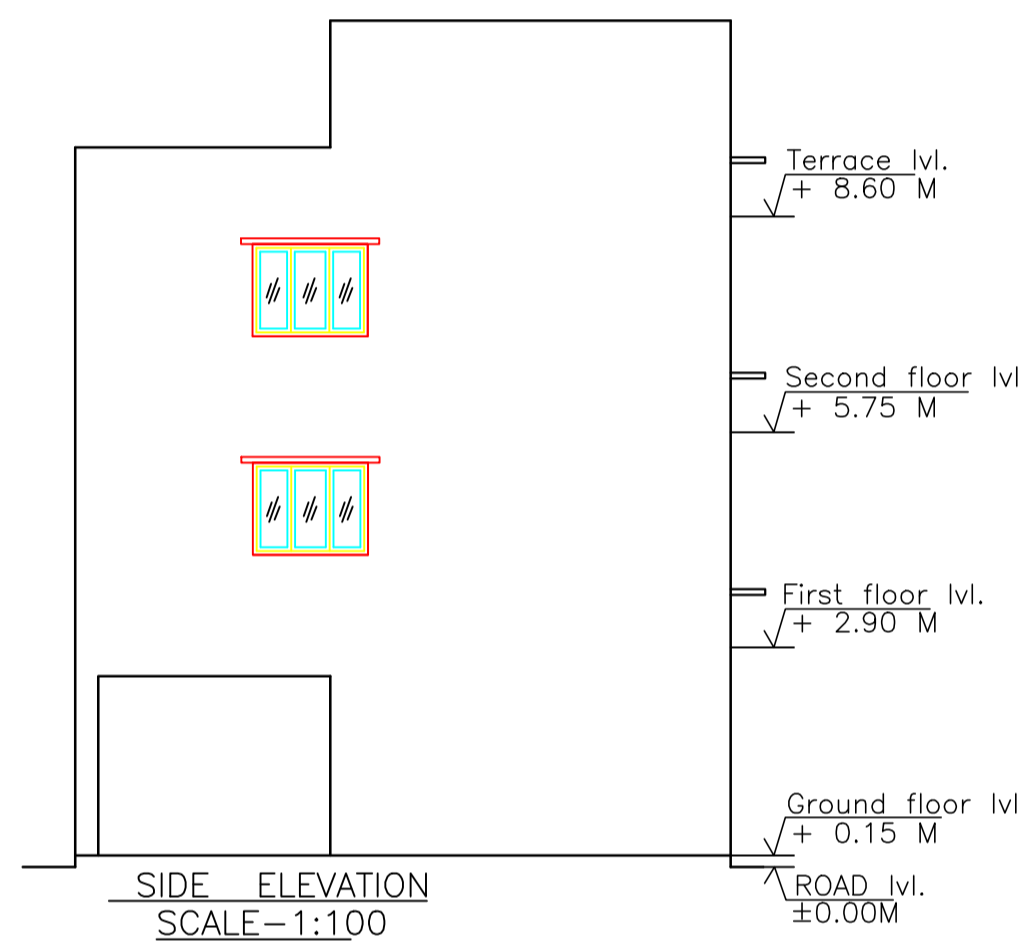

SIDE ELEVATION (SCALE-1:100)

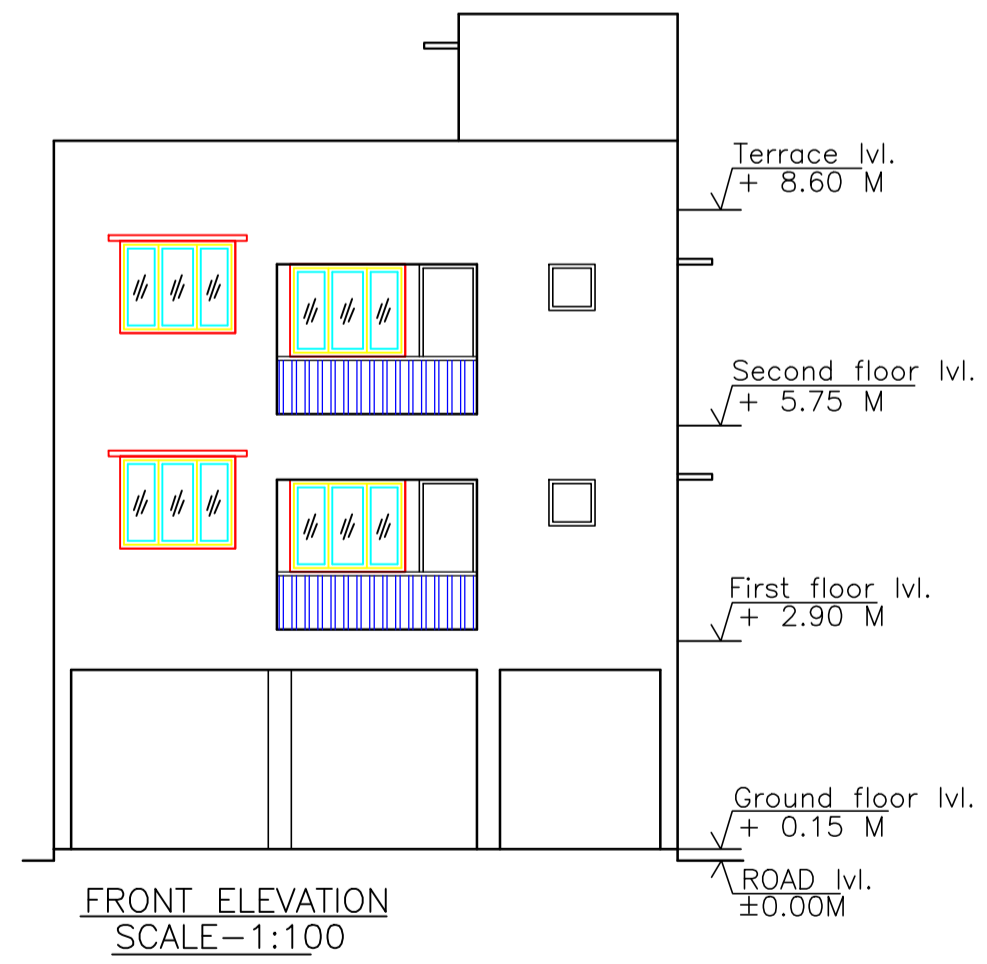

FRONT ELEVATION (SCALE-1:100)

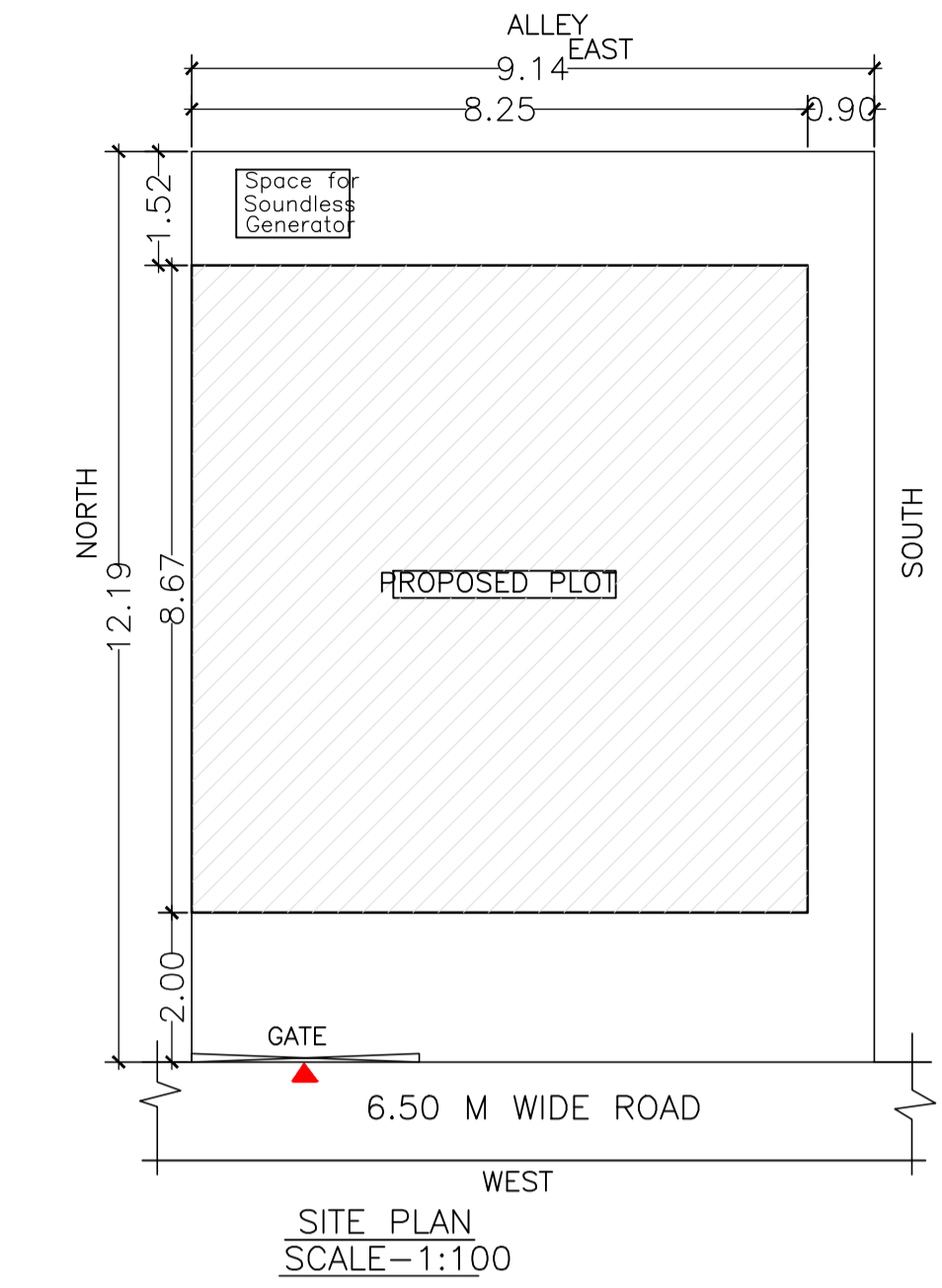

SITE PLAN (SCALE-1:100)

Proposal Basic Information

Proposal File No.	JNAC/P/0088/W7/2021
Owner Name	KAILASH AGARWAL AND OTHERS
Khata No	190 TATA LEASE
Plot No	190 TATA LEASE
Village Name	Sitaramera
Use	Residential
SubUse	Bungalow/ Dwelling / Non Apartment

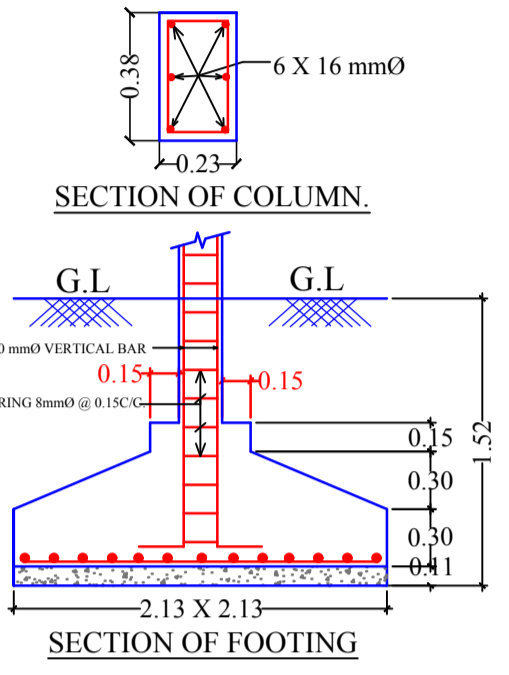

SECTION OF COLUMN

SECTION OF FOOTING

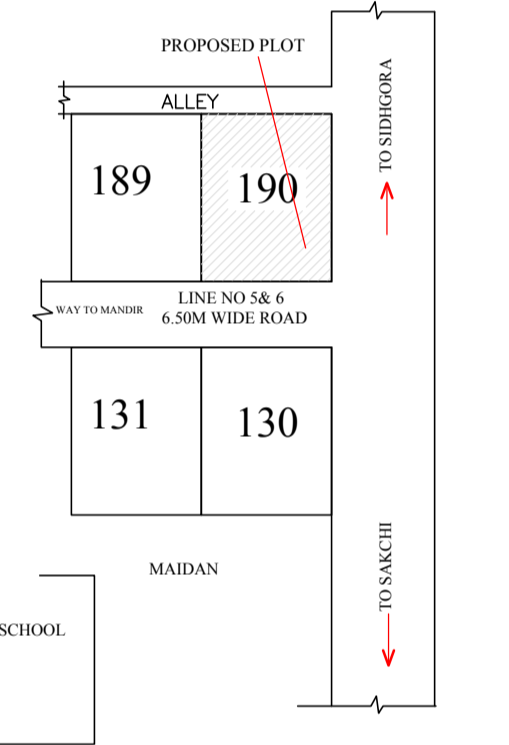

LOCATION PLAN

SCHEDULE OF DOOR:

BUILDING NAME	NAME	LENGTH	HEIGHT	NOS
A (KAILASH AGARWAL AND OTHERS)	D2	0.76	2.10	04
A (KAILASH AGARWAL AND OTHERS)	D1	0.91	2.10	06
A (KAILASH AGARWAL AND OTHERS)	D	1.07	2.10	02

SCHEDULE OF WINDOW/VENTILATION:

BUILDING NAME	NAME	LENGTH	HEIGHT	NOS
A (KAILASH AGARWAL AND OTHERS)	V	0.61	0.61	02
A (KAILASH AGARWAL AND OTHERS)	W	1.22	1.22	05
A (KAILASH AGARWAL AND OTHERS)	W	1.52	1.22	08

UnitBUA Table for Building :A (KAILASH AGARWAL AND OTHERS)

FLOOR	Name	UnitBUA Type	UnitBUA Area	Carpet Area	No. of Rooms	No. of Tenement
FIRST FLOOR PLAN	SPLIT A	FLAT	143.00	142.77	6	1
SECOND FLOOR PLAN	SPLIT A	FLAT	0.00	0.00	6	0
Total:	-	-	143.00	142.77	12	1

Building :A (KAILASH AGARWAL AND OTHERS)

Floor Name	Total Built Up Area (Sq.mt.)	Deductions (Area in Sq.mt.)	Proposed FAR Area (Sq.mt.)	Add Area In FAR (Sq.mt.)	Total FAR Area (Sq.mt.)	Total Consumed Additional FAR Area (Sq.mt.)	Trmt (No.)
Parking Floor	71.50	62.46	0.00	9.04	9.04	9.04	00
First Floor	71.50	0.00	71.50	0.00	71.50	71.50	01
Second Floor	71.50	0.00	71.50	0.00	71.50	71.50	00
Terrace Floor	0.00	0.00	0.00	0.00	0.00	0.00	00
Total :	214.50	62.46	143.00	9.04	152.04	152.04	01
Total Number of Same Buildings	1						
Total :	214.50	62.46	143.00	9.04	152.04	152.04	01

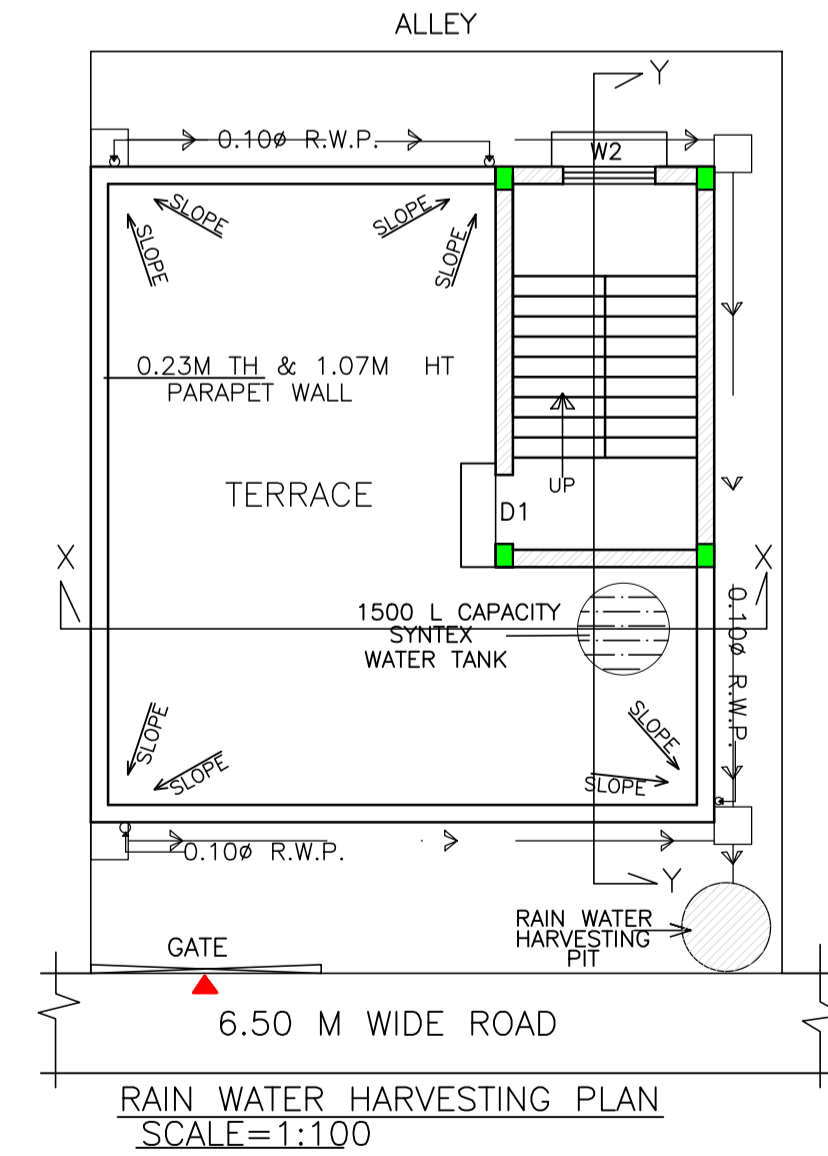

RAIN WATER HARVESTING PLAN (SCALE=1:100)

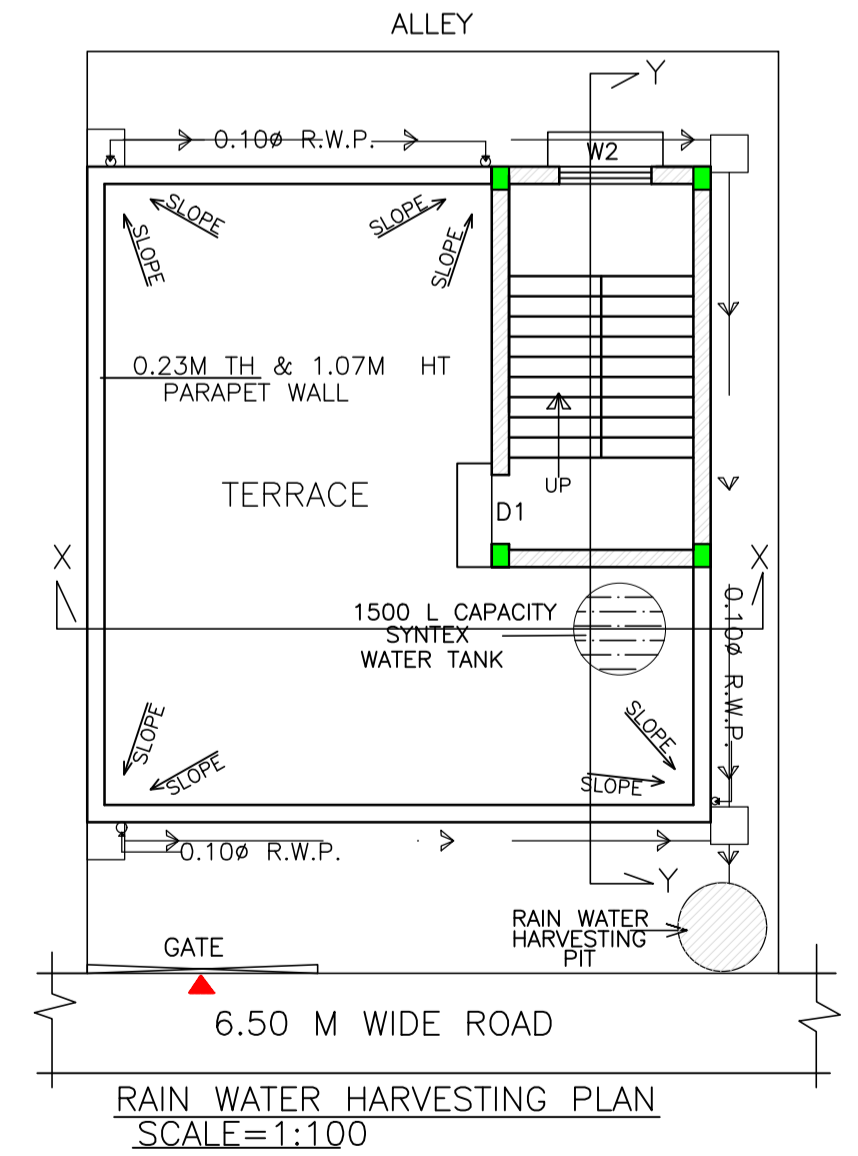

RAIN WATER HARVESTING PLAN (SCALE=1:100)

LTP NAME AND SIGNATURE	STRUCTURAL ENG'S NAME AND SIGNATURE	BUILDER NAME AND SIGNATURE	DIGITAL SIGNATURE
NIKHIL SHUKLA JNAC/ARC/0015/2019			