

Proposal Basic Information	
Proposal File No.	JNAC/BP/0097/W12/2021
Owner Name	GEORGE LUCAS
Khata No	Nil
Plot No	16
Village Name	Sitaramdera
Use	Residential
SubUse	Bungalow/ Dwelling / Non Apartment

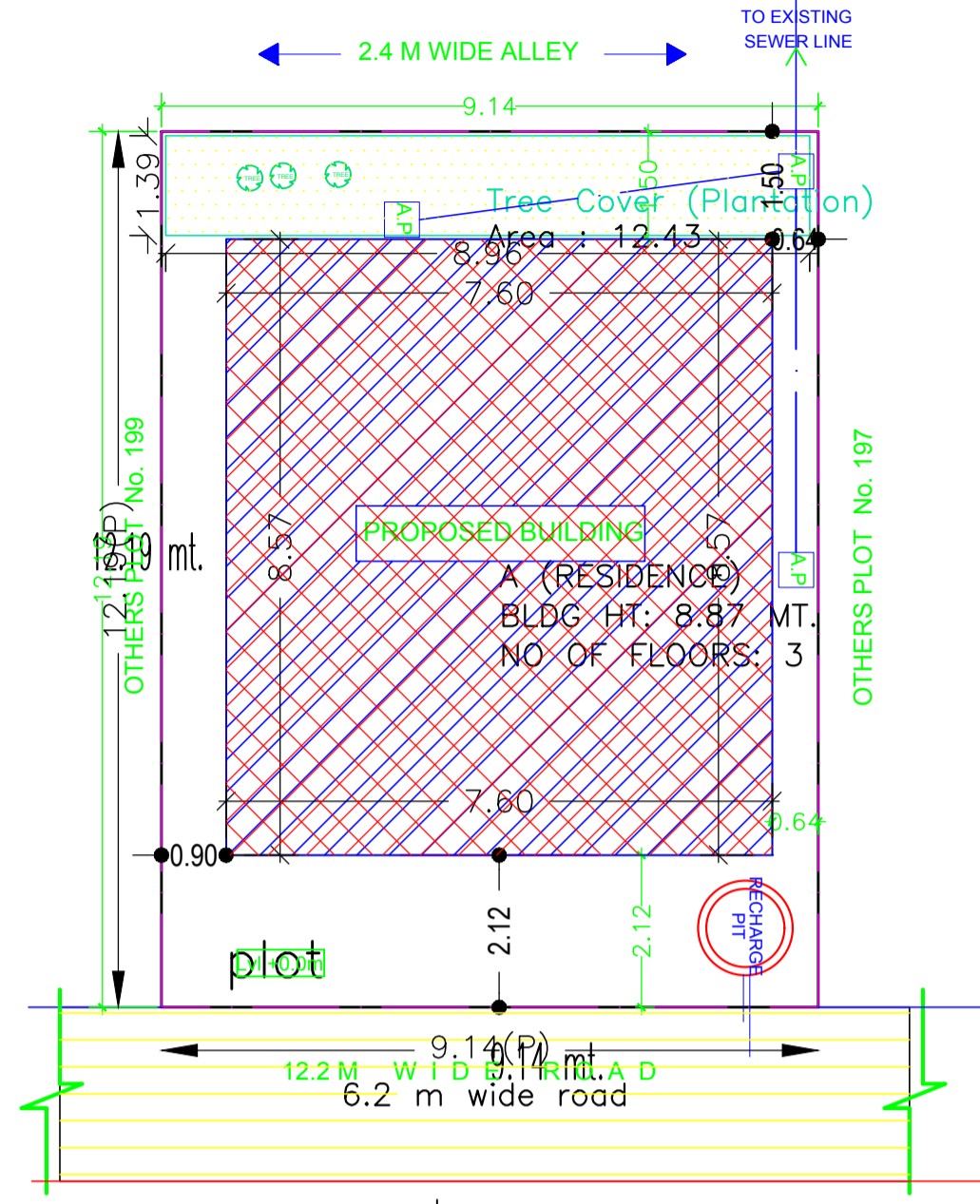

KEY PLAN  
SCALE-1:100  
site

AREA STATEMENT	VERSION NO.: 1.0.62		
JAMSHEDPUR NAC	VERSION DATE: 16/10/2020		
PROJECT DETAIL:			
Region: JHARKHAND URBAN LOCAL BODIES	Plot Use: Residential		
District: EAST SINGHBHUM	Plot SubUse: Bungalow/ Dwelling / Non Apartment		
Authority: JAMSHEDPUR NAC	Plot/Nearby/Religious Structure: NA		
Inward No: JNAC/BP/0097/W12/2021	Plot/SubPlot No: 16		
Application Type: General Proposal	North: Road Width - 6.5		
Project Type: Building Permission	South: Road Width - 2.4		
Nature of Development: New	East: Plot No. - 17		
Location of Development Area: New Area	West: Plot No. - 15		
AREA DETAILS:			
AREA OF PLOT (Minimum)	(A)	SQ.MT.	111.42
NET AREA OF PLOT(Gross Plot Area - Deduction from Gross Plot area)	(A-Deductions)		111.42
Deduction for Balance Plot Area(from Gross Plot Area)			
Common Plot			12.43
Total			12.43
BALANCE AREA OF PLOT(Net Plot Area - Recreational/Amenity space)	(A-Deductions)		98.99
PLOT AREA FOR COVERAGE(Net Plot Area)	(A-Deductions)		111.42
Plot Area for FAR (Net Plot Area + Road Widening Area)	(A-Deductions)		111.42
COVERAGE CHECK			
Permissible Coverage area ( 70.00 % )			77.99
Proposed Coverage Area ( 58.47 % )			65.15
Total Prop. Coverage Area ( 58.47 % )			65.15
Balance coverage area ( 11.52 % )			12.84
FAR CHECK			
Perm. FAR Area ( 2.00 )			222.84
Total Perm. FAR area			222.84
Residential FAR			130.29
Proposed FAR Area			139.01
Total Proposed FAR Area			139.01
Consumed FAR (Factor)			1.25
Balance FAR Area			83.83
BUILT UP AREA CHECK			
Total Proposed BuiltUp Area			195.44
ARCHITECT (Regd)		SUMANA BASACK	
ENGINEER (Regd)			
SUPERVISOR (Regd)			
OWNER (Regd)		GEORGE LUCAS	
DEVELOPMENT AUTHORITY		LOCAL BODY	

COLOR INDEX	
PLOT BOUNDARY	Black
ABUTTING ROAD	Green
PROPOSED CONSTRUCTION	Red
COMMON PLOT	Blue
ROAD WIDENING AREA	Yellow
EXISTING (To be retained)	Orange
EXISTING (To be demolished)	Purple

Buildingwise Floor FAR Details

Floor Name	Building Name		Total	
	Proposed Built Up Area (Sq.mt.)	Proposed FAR Area (Sq.mt.)	Total Proposed Built Up Area (Sq.mt.)	Total FAR Area (Sq.mt.)
Ground Floor	65.14	8.71	65.14	8.71
First Floor	65.15	65.15	65.15	65.15
Second Floor	65.15	65.15	65.15	65.15
Terrace Floor	0.00	0.00	0.00	0.00
Total :	195.44	139.01	195.44	139.01

Building USE/SUBUSE Details

Building Name	Building Use	Building SubUse	Building Structure
A (RESIDENCE)	Residential	Residential Bldg/Apartment	Non-Highrise

Required Parking(Table 7a)

Building Name	SubUse	Area (Sq.mt.)	Units		Car		Visitors Car		Reqd./Unit	Reqd.	Prop.		
			Prop.	Reqd./Unit	Prop.	Reqd.	Prop.	Reqd./Unit					
A (RESIDENCE)	Residential	Residential Bldg/Apartment	> 0	1	2.00	1.00	2	-	-	-	-	-	
			> 0	1	2.00	-	-	-	-	-	1	2	-
			> 0	1	2.00	-	-	-	1	1	-	-	-
Total :			-	-	-	2	2	-	1	1	-	2	3

Parking Check (Table 7b)

Vehicle Type	Reqd.		Prop.	
	No.	Area	No.	Area
Car	-	25.00	2	25.00
		25.00	2	25.00
		-	1	12.50
Total Visitor Parking	1	-	1	12.50
		-		
Total TwoWheeler				6.00
Other Parking				12.93
Total		41.50		62.43

FAR & Tenement Details (Table 4c-1)

Building	No. of Same Bldg	Total Built Up Area (Sq.mt.)	Deductions (Area in Sq.mt.)		Proposed FAR Area (Sq.mt.)	Add Area In FAR (Sq.mt.)	Total FAR Area (Sq.mt.)	Total Consumed Additional FAR Area (Sq.mt.)	Tnmt (No.)
			Parking	Resi.					
A (RESIDENCE)	1	195.44	56.43	130.30	8.71	139.01	139.01	02	
Grand Total :	1	195.44	56.43	130.30	8.71	139.01	139.01	02	

LTP NAME AND SIGNATURE	STRUCTURAL ENG'S NAME AND SIGNATURE	BUILDER NAME AND SIGNATURE	DIGITAL SIGNATURE
SUMANA BASACK JNAC/ARC/0011/2017			

Proposal Basic Information

Proposal File No.	JNAC/BP/0097/W12/2021
Owner Name	GEORGE LUCAS
Khata No	Nil
Plot No	16
Village Name	Sitaramdera
Use	Residential
SubUse	Bungalow/ Dwelling / Non Apartment

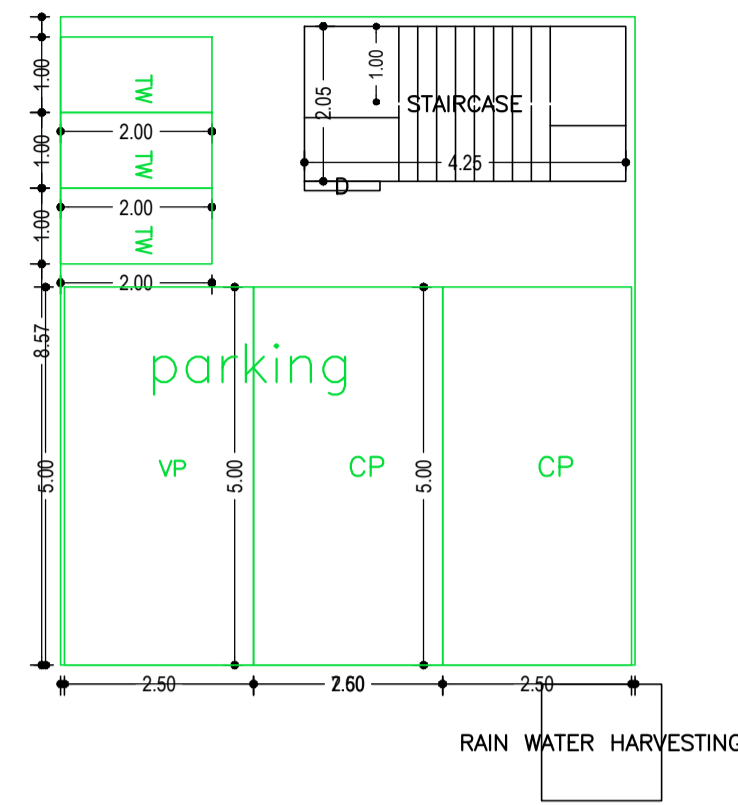

GROUND FLOOR PLAN (SCALE 1:100)

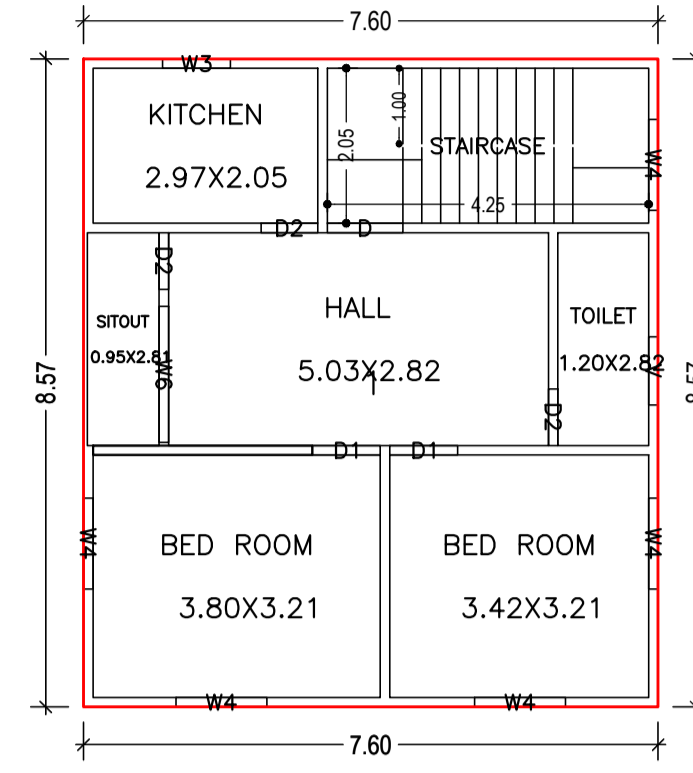

FIRST FLOOR PLAN (Proposed) (SCALE 1:100)

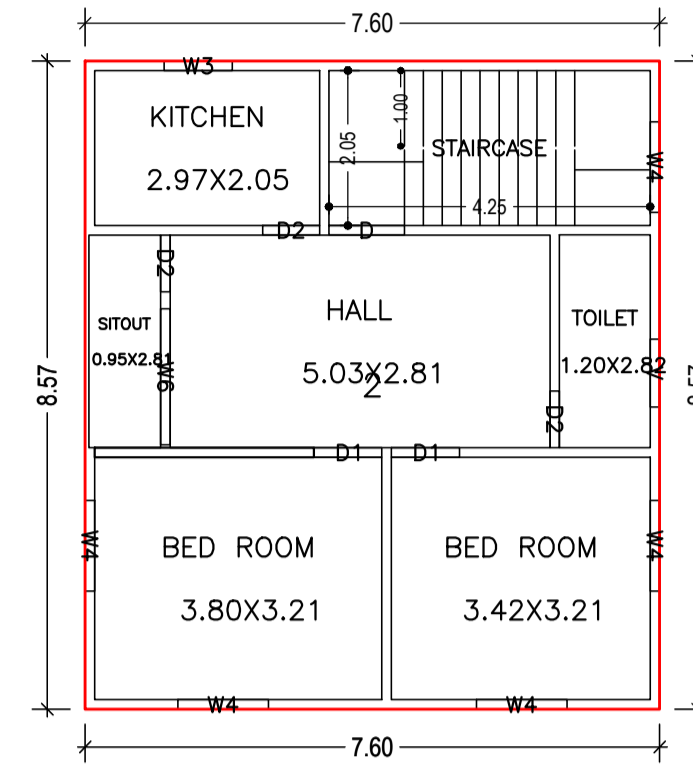

SECOND FLOOR PLAN (Proposed) (SCALE 1:100)

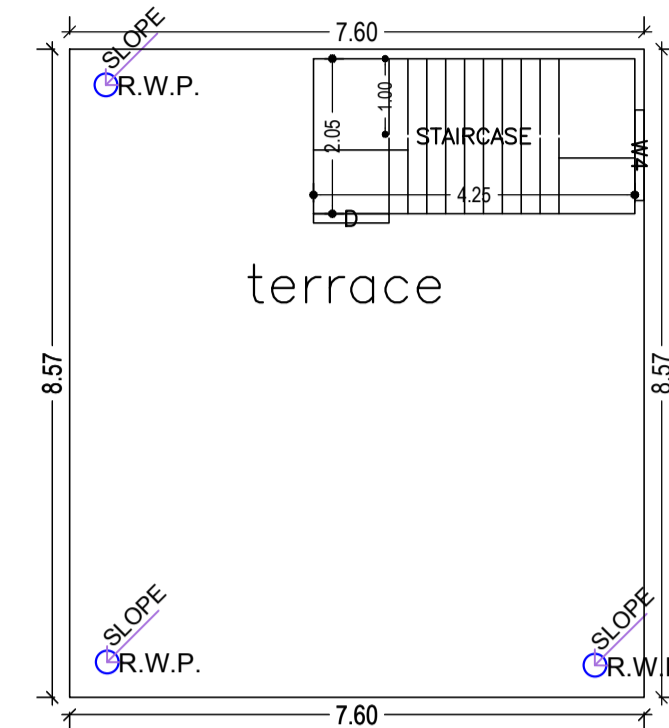

TERRACE FLOOR PLAN (SCALE 1:100)

Building :A (RESIDENCE)

Floor Name	Total Built Up Area (Sq.mt.)	Deductions (Area in Sq.mt.)		Proposed FAR Area (Sq.mt.)	Add Area In FAR (Sq.mt.)	Total FAR Area (Sq.mt.)	Total Consumed Additional FAR Area (Sq.mt.)	Tnmt (No.)
		Parking	Resi.					
Ground Floor	65.14	56.43	0.00	8.71	8.71	8.71	0.00	
First Floor	65.15	0.00	65.15	0.00	65.15	65.15	0.00	
Second Floor	65.15	0.00	65.15	0.00	65.15	65.15	0.00	
Terrace Floor	0.00	0.00	0.00	0.00	0.00	0.00	0.00	
Total :	195.44	56.43	130.30	8.71	139.01	139.01	0.00	
Total Number of Same Buildings :	1							
Total :	195.44	56.43	130.30	8.71	139.01	139.01	0.00	

SCHEDULE OF DOOR:

BUILDING NAME	NAME	LENGTH	HEIGHT	NOS
A (RESIDENCE)	D2	0.75	2.10	06
A (RESIDENCE)	D1	0.90	2.10	04
A (RESIDENCE)	D	1.00	2.10	02

SCHEDULE OF WINDOW/VENTILATION:

BUILDING NAME	NAME	LENGTH	HEIGHT	NOS
A (RESIDENCE)	V	0.90	0.60	02
A (RESIDENCE)	W3	0.90	1.20	02
A (RESIDENCE)	W4	1.20	1.20	11
A (RESIDENCE)	W6	1.80	1.20	02

UnitBUA Table for Building :A (RESIDENCE)

FLOOR	Name	UnitBUA Type	UnitBUA Area	Carpet Area	No. of Rooms	No. of Tenement
FIRST FLOOR PLAN	1	FLAT	65.15	64.78	6	1
SECOND FLOOR PLAN	2	FLAT	65.15	64.78	6	1
Total:	-	-	130.30	129.56	12	2

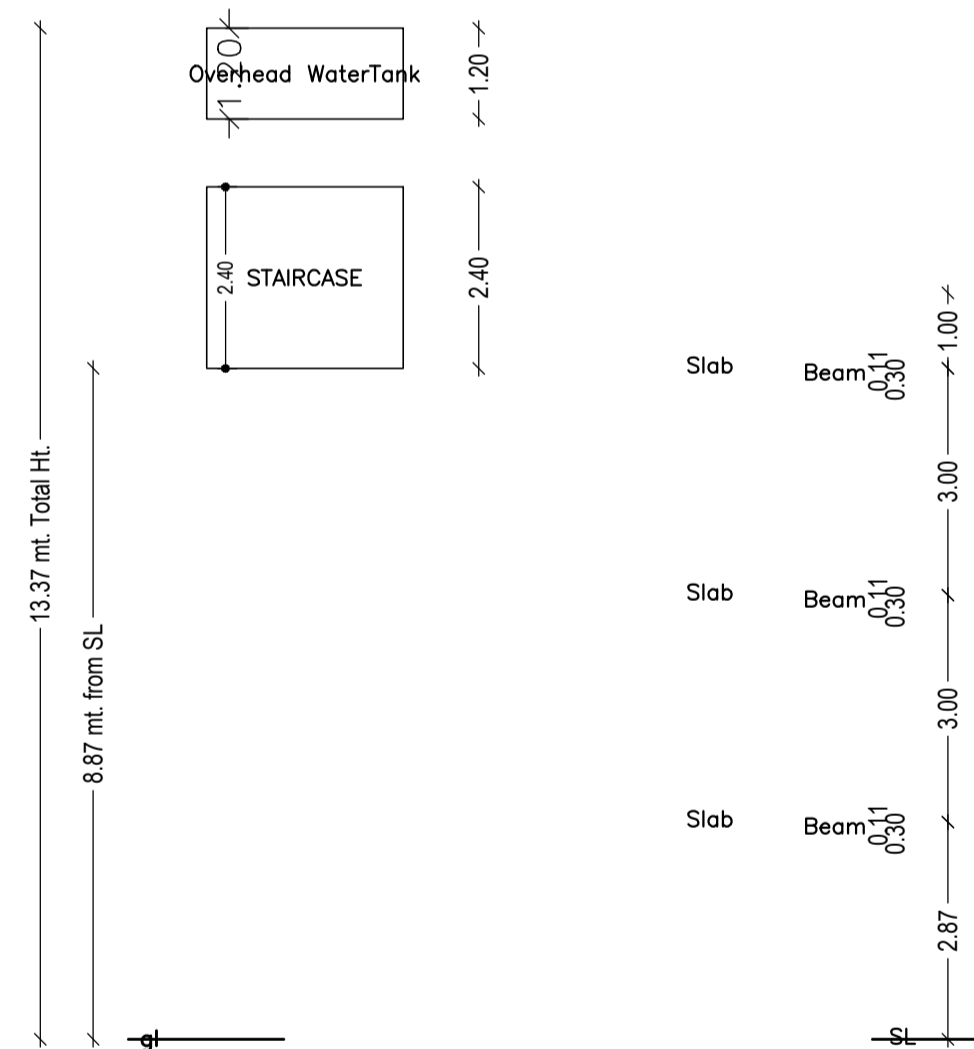
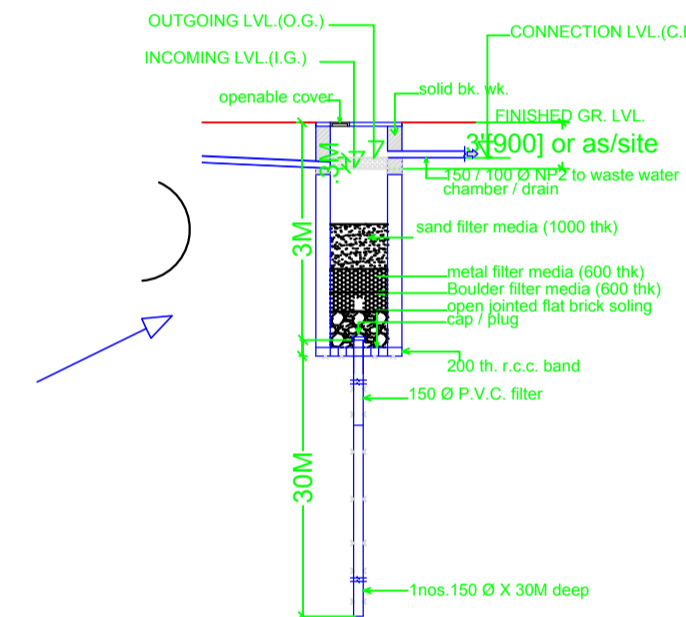

LTP NAME AND SIGNATURE	STRUCTURAL ENG'S NAME AND SIGNATURE	BUILDER NAME AND SIGNATURE	DIGITAL SIGNATURE
SUMANA BASACK JNAC/ARC/0011/2017			

Proposal Basic Information

Proposal File No.	JNAC/BP/0097/W12/2021
Owner Name	GEORGE LUCAS
Khata No	Nil
Plot No	16
Village Name	Sitaramdera
Use	Residential
SubUse	Bungalow/ Dwelling / Non Apartment

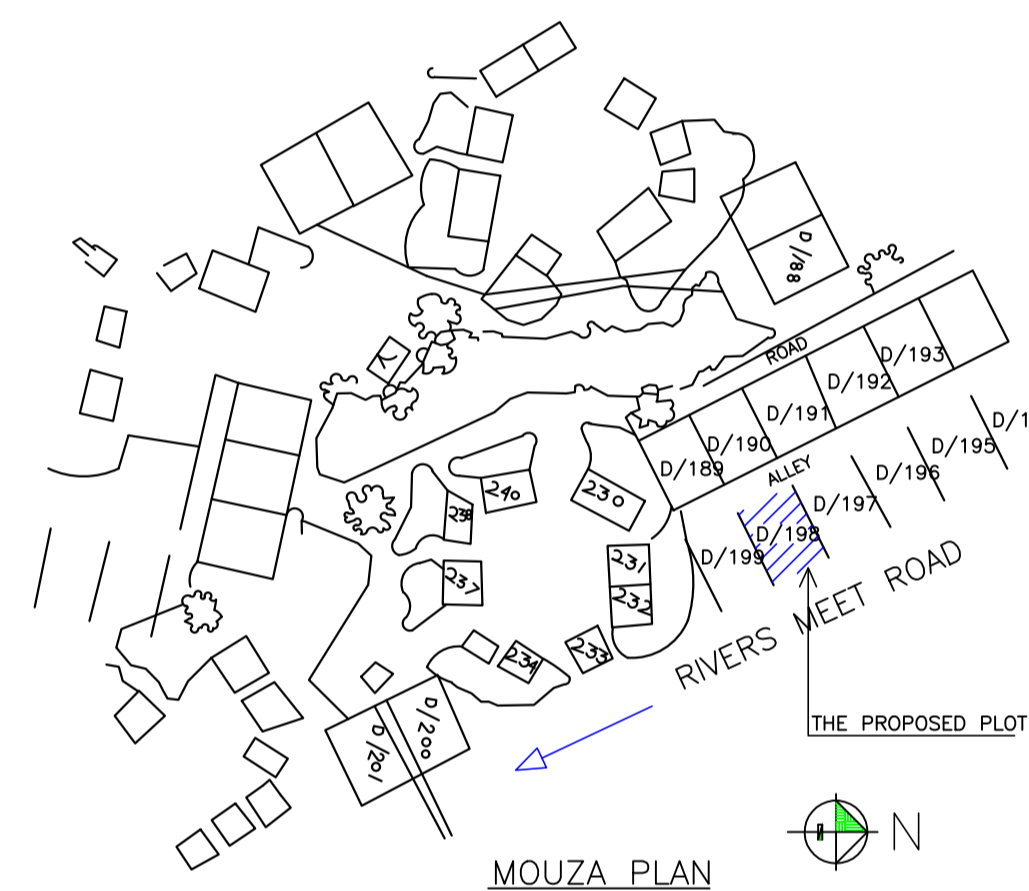
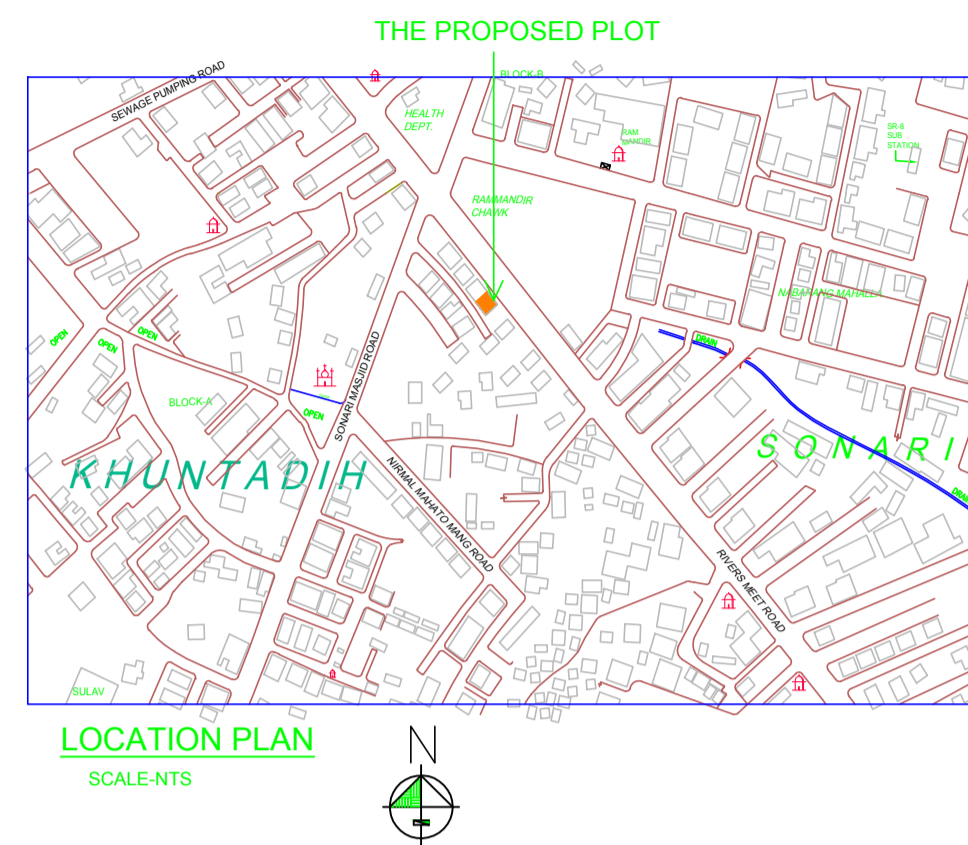
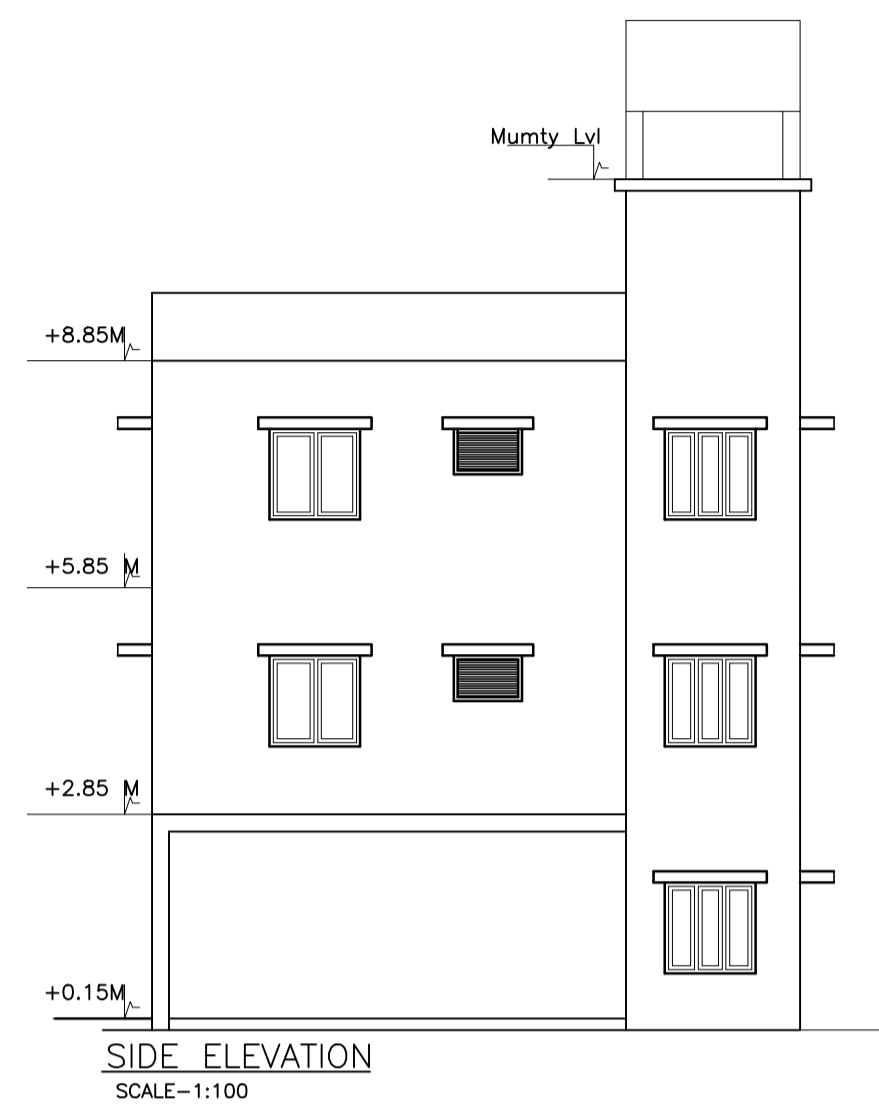
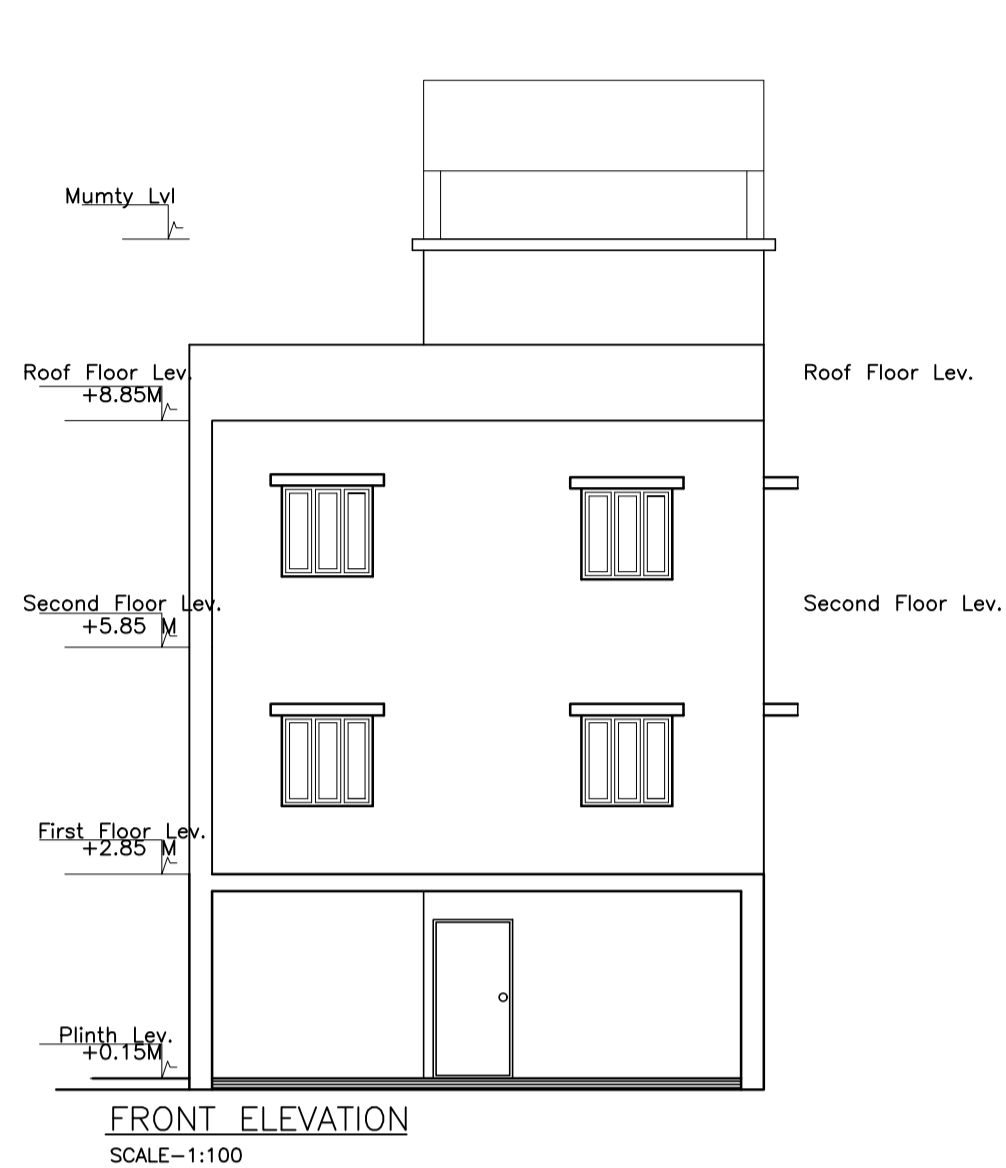

LTP NAME AND SIGNATURE	STRUCTURAL ENG'S NAME AND SIGNATURE	BUILDER NAME AND SIGNATURE	DIGITAL SIGNATURE
SUMANA BASACK JNAC/ARC/0011/2017			