

Proposal Basic Information	
Proposal File No.	JNAC/BP/0102/W9/2021
Owner Name	MD MAZHARUL HAQUE
Khata No	NIL
Plot No	347
Village Name	Sitaramdera
Use	Residential
SubUse	Row House

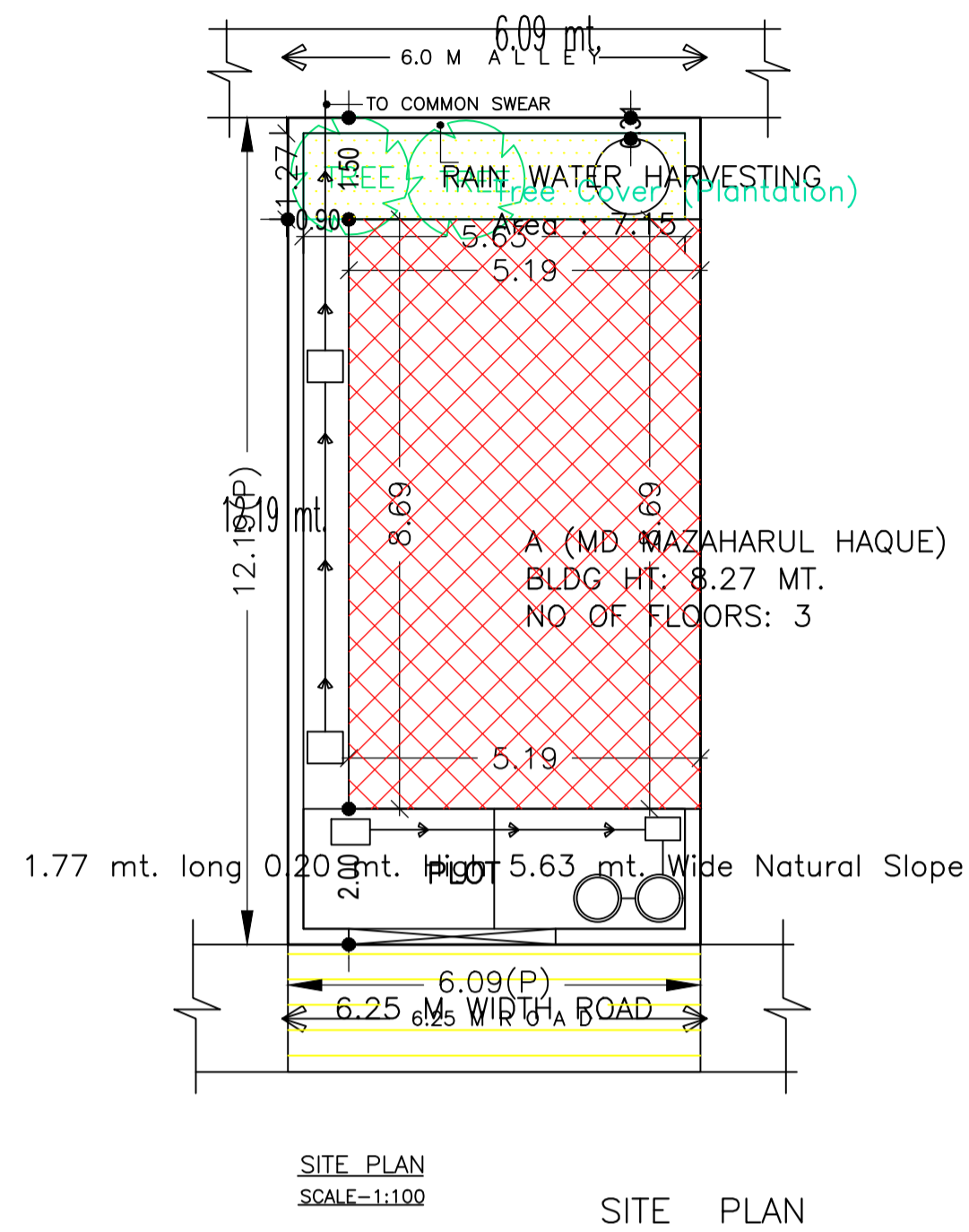

AREA STATEMENT		VERSION NO.: 1.0.61
JAMSHEDPUR NAC		VERSION DATE: 16/10/2020
PROJECT DETAIL:		
Region: JHARKHAND URBAN	Plot Use: Residential	
LOCAL BODIES	Plot SubUse: Row House	
District: EAST SINGHBHUM	Plot/Nearby/Religious/Structure: NA	
Authority: JAMSHEDPUR NAC	Plot/SubPlot No: 347	
Inward No: JNAC/BP/0102/W9/2021	North: Plot No. - 348	
Application Type: General Proposal	South: Plot No. - 346	
Project Type: Building Permission	East: Road Width - 9.0	
Nature of Development: New	West: Road Width - 4.5	
Location of Development Area: Old Area		
AREA DETAILS:		SQ.MT.
AREA OF PLOT (Minimum)	(A)	74.27
NET AREA OF PLOT(Gross Plot Area - Deduction from Gross Plot area)	(A-Deductions)	74.27
Deduction for Balance Plot Area(from Gross Plot Area)		
Common Plot		7.15
Total		7.15
BALANCE AREA OF PLOT(Net Plot Area - Recreational/Amenity space)	(A-Deductions)	67.12
PLOT AREA FOR COVERAGE(Net Plot Area)	(A-Deductions)	74.27
Plot Area for FAR (Net Plot Area + RoadWidening Area)	(A-Deductions)	74.27
COVERAGE CHECK		
Permissible Coverage area ( 70.00 % )		51.99
Proposed Coverage Area ( 60.77 % )		45.13
Total Prop. Coverage Area ( 60.77 % )		45.13
Balance coverage area ( 9.24 % )		6.86
FAR CHECK		
Perm. FAR Area ( 2.50 )		185.67
Total Perm. FAR area		185.67
Residential FAR		90.25
Proposed FAR Area		101.61
Total Proposed FAR Area		101.61
Consumed FAR (Factor)		1.37
Balance FAR Area		84.06
BUILT UP AREA CHECK		
Total Proposed BuiltUp Area		135.39
ARCHITECT (Regd)	SHREYASHI PAUL	
ENGINEER (Regd)		
SUPERVISOR (Regd)		
OWNER (Regd)	MD MAZHARUL HAQUE	
DEVELOPMENT AUTHORITY		LOCAL BODY

FAR & Tenement Details (Table 4c-1)

Building	No. of Same Bldg	Total Built Up Area (Sq.mt.)	Deductions (Area in Sq.mt.)		Add Area In FAR (Sq.mt.)	Total FAR Area (Sq.mt.)	Total Consumed Additional FAR Area (Sq.mt.)	Trnmt (No.)
			Parking	Resi.				
A (MD MAZHARUL HAQUE)	1	135.39	33.78	90.26	11.35	101.61	101.61	01
Grand Total :	1	135.39	33.78	90.26	11.35	101.61	101.61	01

COLOR INDEX	
PLOT BOUNDARY	
ABUTTING ROAD	
PROPOSED CONSTRUCTION	
COMMON PLOT	
ROAD WIDENING AREA	
EXISTING (To be retained)	
EXISTING (To be demolished)	

Buildingwise Floor FAR Details

Floor Name	Building Name		Total	
	Proposed Built Up Area (Sq.mt.)	Proposed FAR Area (Sq.mt.)	Total Proposed Built Up Area (Sq.mt.)	Total FAR Area (Sq.mt.)
Parking Floor	45.13	11.35	45.13	11.35
First Floor	45.13	45.13	45.13	45.13
Second Floor	45.13	45.13	45.13	45.13
Terrace Floor	0.00	0.00	0.00	0.00
Total :	135.39	101.61	135.39	101.61

Building USE/SUBUSE Details

Building Name	Building Use	Building SubUse	Building Structure
A (MD MAZHARUL HAQUE)	Residential	Row House	Non-Highrise

LTP NAME AND SIGNATURE	STRUCTURAL ENG'S NAME AND SIGNATURE	BUILDER NAME AND SIGNATURE	DIGITAL SIGNATURE
SHREYASHI PAUL JNAC/DFTMN/0009/2016			

Proposal Basic Information

Proposal File No.	JNAC/BP/0102/W9/2021
Owner Name	MD MAZHARUL HAQUE
Khata No	NIL
Plot No	347
Village Name	Sitaramdera
Use	Residential
SubUse	Row House

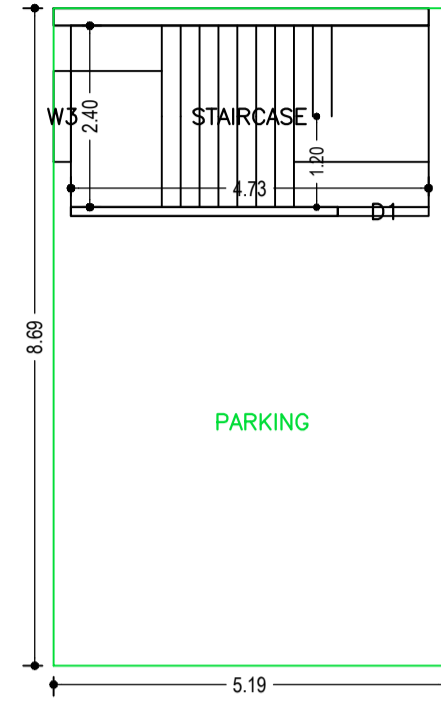

PARKING FLOOR PLAN  
(SCALE 1:100)

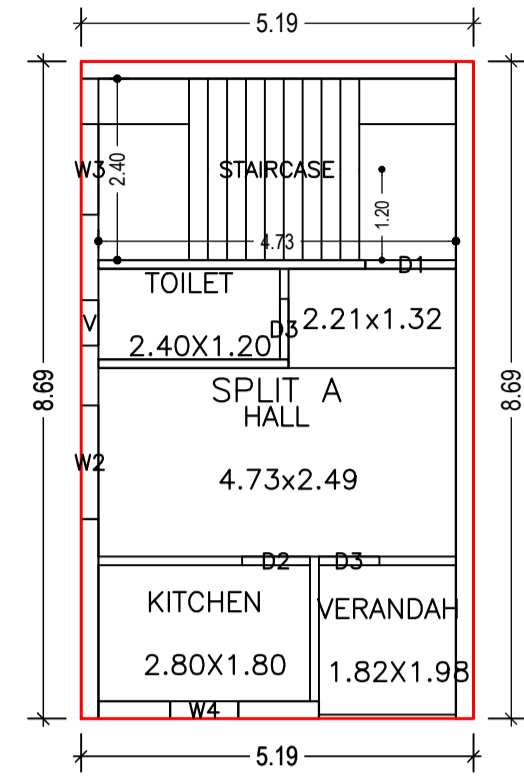

FIRST FLOOR PLAN  
(Proposed)  
(SCALE 1:100)

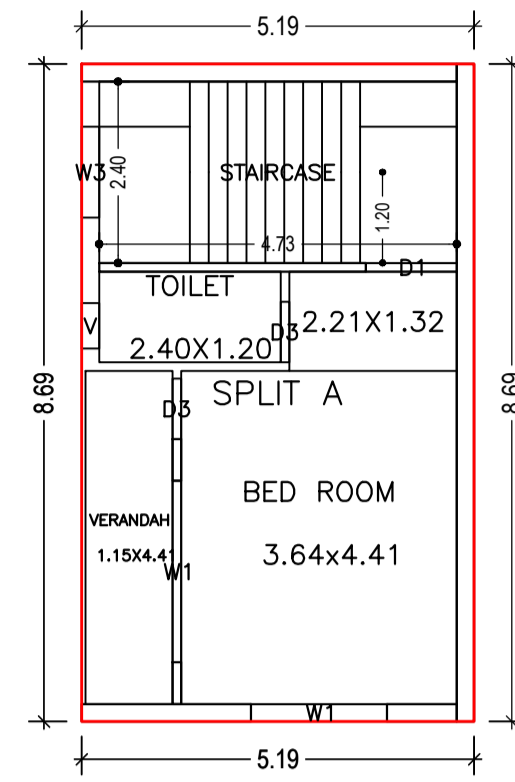

SECOND FLOOR PLAN  
(Proposed)  
(SCALE 1:100)

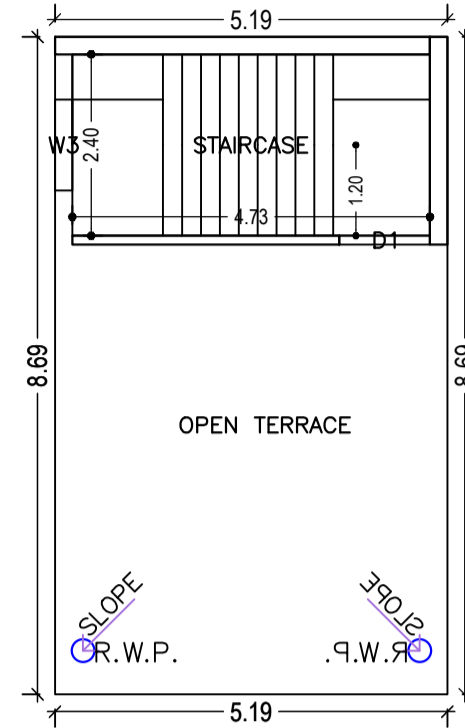

TERRACE FLOOR PLAN  
(SCALE 1:100)

Building :A (MD MAZHARUL HAQUE)

Floor Name	Total Built Up Area (Sq.mt.)	Deductions (Area in Sq.mt.)	Proposed FAR Area (Sq.mt.)	Add Area In FAR (Sq.mt.)	Total FAR Area (Sq.mt.)	Total Consumed Additional FAR Area (Sq.mt.)	Tnmt (No.)
Parking Floor	45.13	33.78	0.00	11.35	11.35	11.35	00
First Floor	45.13	0.00	45.13	0.00	45.13	45.13	01
Second Floor	45.13	0.00	45.13	0.00	45.13	45.13	00
Terrace Floor	0.00	0.00	0.00	0.00	0.00	0.00	00
Total :	135.39	33.78	90.26	11.35	101.61	101.61	01
Total Number of Same Buildings :	1						
Total :	135.39	33.78	90.26	11.35	101.61	101.61	01

SCHEDULE OF DOOR:

BUILDING NAME	NAME	LENGTH	HEIGHT	NOS
A (MD MAZHARUL HAQUE)	D3	0.80	2.10	04
A (MD MAZHARUL HAQUE)	D2	0.90	2.10	01
A (MD MAZHARUL HAQUE)	D1	1.20	2.10	02

SCHEDULE OF WINDOW/VENTILATION:

BUILDING NAME	NAME	LENGTH	HEIGHT	NOS
A (MD MAZHARUL HAQUE)	V	0.60	0.60	02
A (MD MAZHARUL HAQUE)	W4	0.90	1.20	01
A (MD MAZHARUL HAQUE)	W3	1.20	1.20	04
A (MD MAZHARUL HAQUE)	W2	1.50	1.20	01
A (MD MAZHARUL HAQUE)	W1	1.80	1.20	01
A (MD MAZHARUL HAQUE)	W1	2.40	1.20	01

UnitBUA Table for Building :A (MD MAZHARUL HAQUE)

FLOOR	Name	UnitBUA Type	UnitBUA Area	Carpet Area	No. of Rooms	No. of Tenement
FIRST FLOOR PLAN	SPLIT A	FLAT	90.25	80.95	4	1
SECOND FLOOR PLAN	SPLIT A	FLAT	0.00	0.00	3	0
Total:	-	-	90.25	80.95	7	1

LTP NAME AND SIGNATURE	STRUCTURAL ENG'S NAME AND SIGNATURE	BUILDER NAME AND SIGNATURE	DIGITAL SIGNATURE
SHREYASHI PAUL JNAC/DFTMN/0009/2016			

Proposal Basic Information

Proposal File No.	JNAC/BP/0102/W9/2021
Owner Name	MD MAZHARUL HAQUE
Khata No	NIL
Plot No	347
Village Name	Sitaramdera
Use	Residential
SubUse	Row House

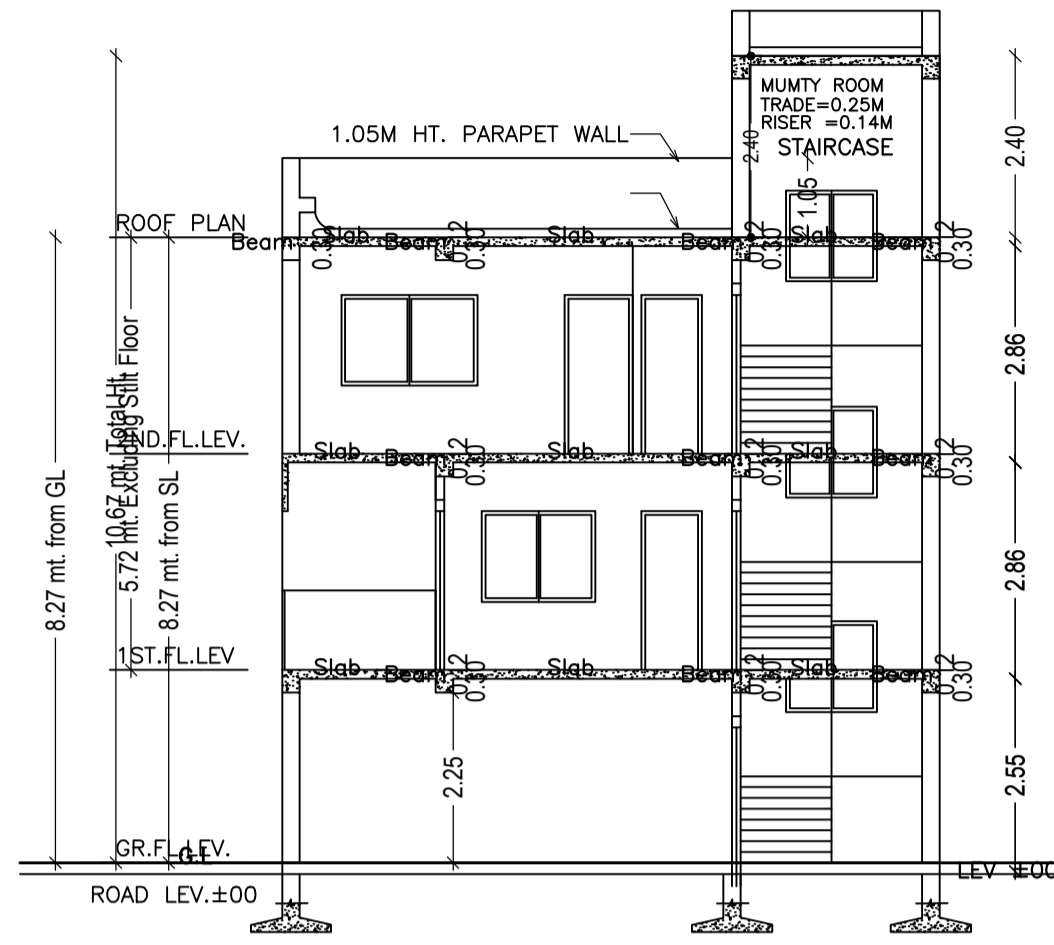

SECTION - Y-Y  
SCALE=1:100

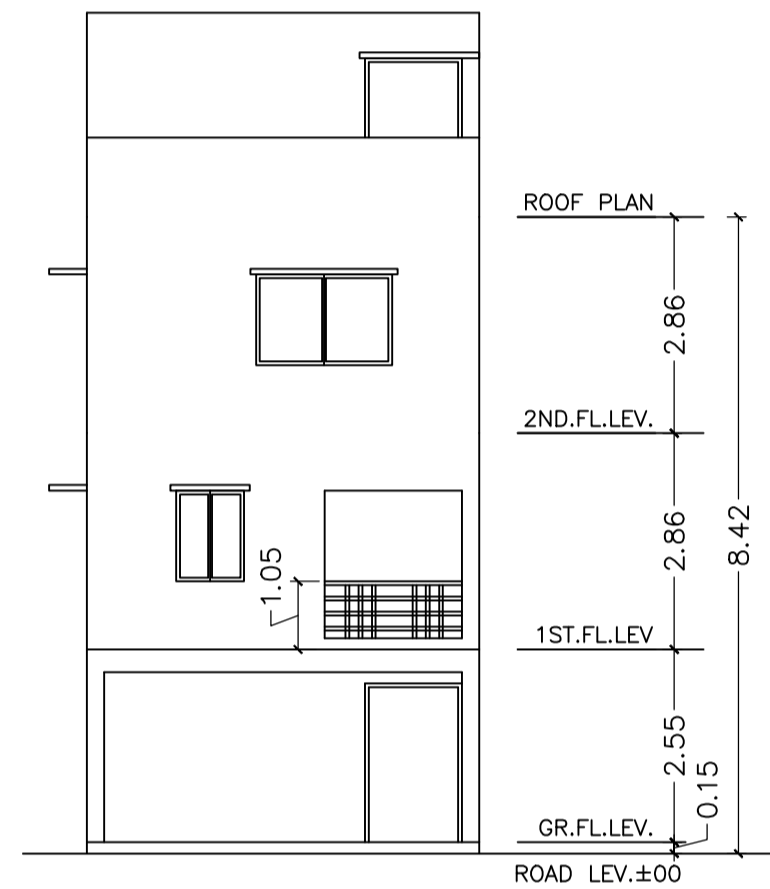

FRONT ELEVATION  
SCALE=1:100

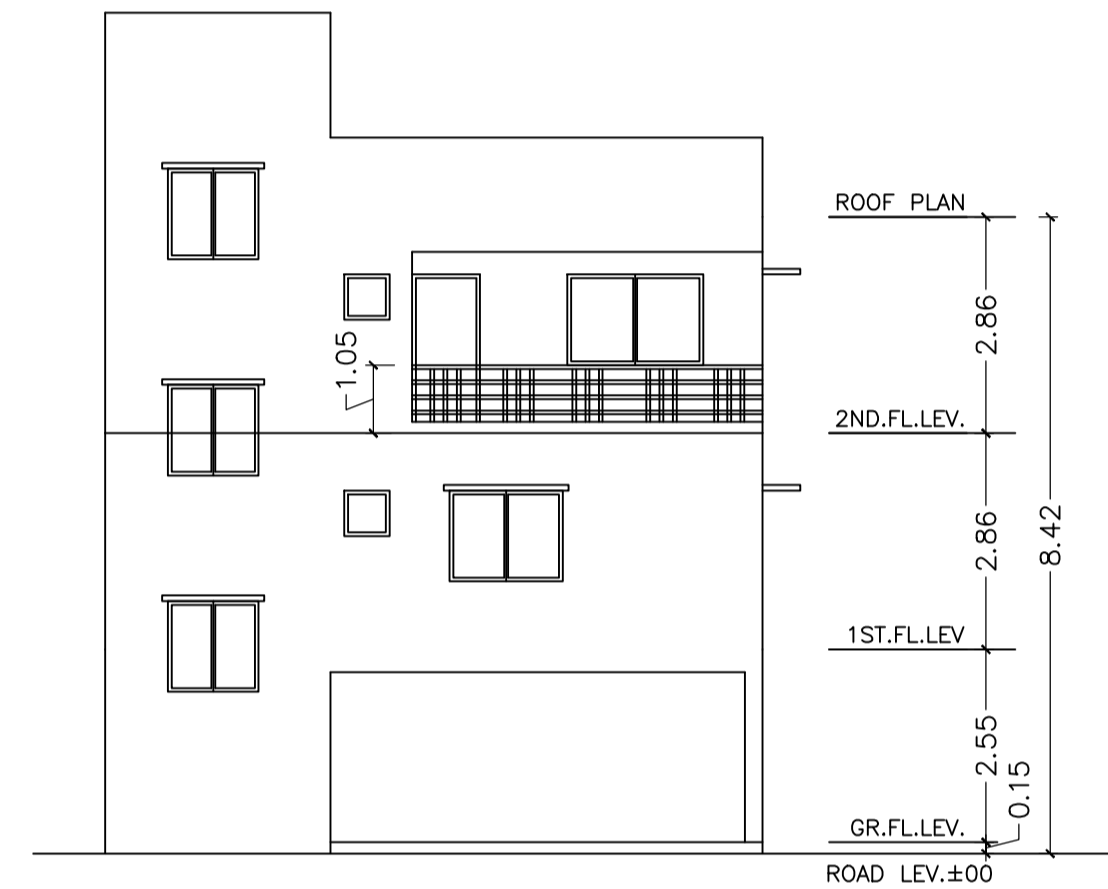

SIDE ELEVATION  
SCALE=1:100

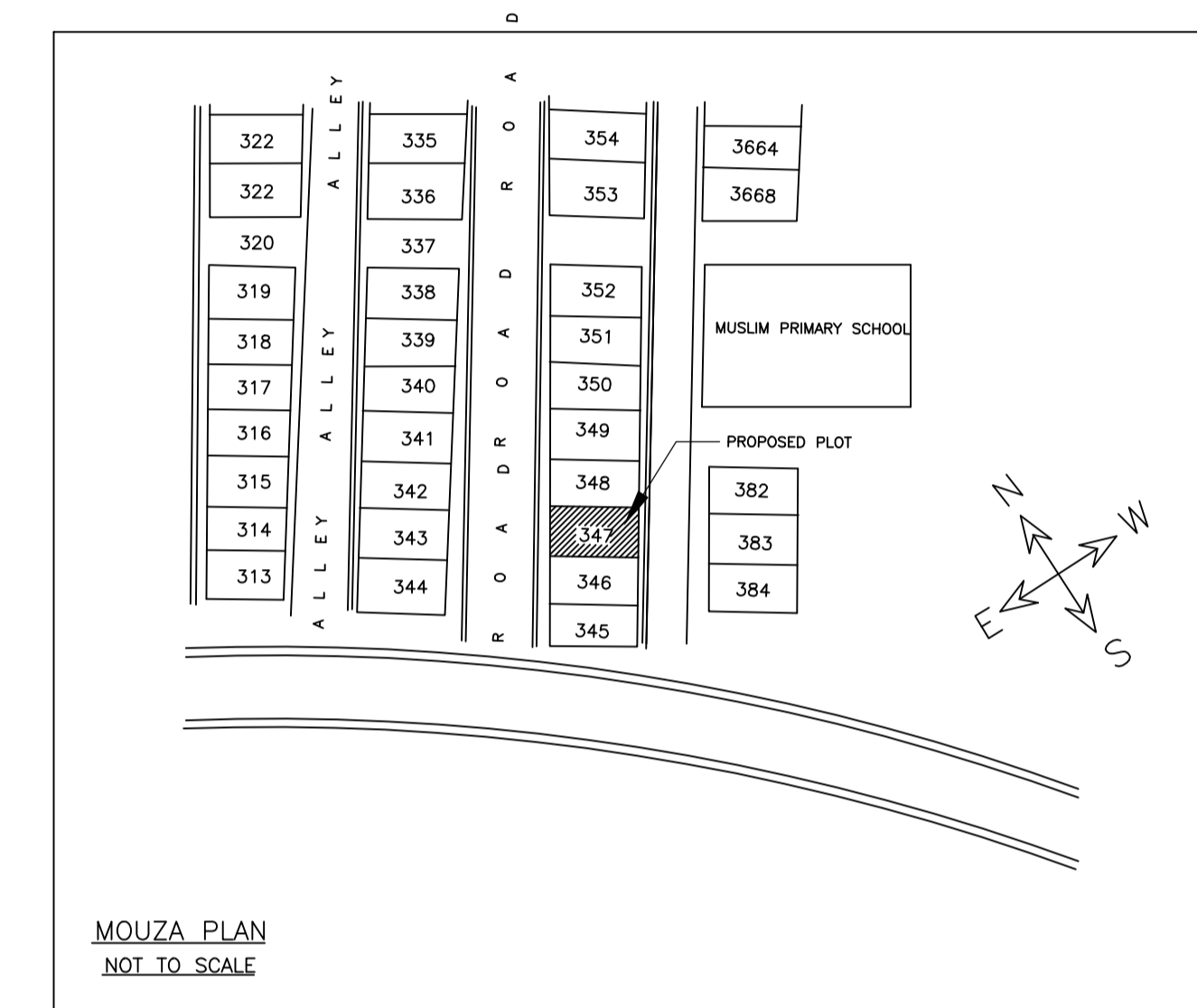

MOUZA PLAN  
NOT TO SCALE

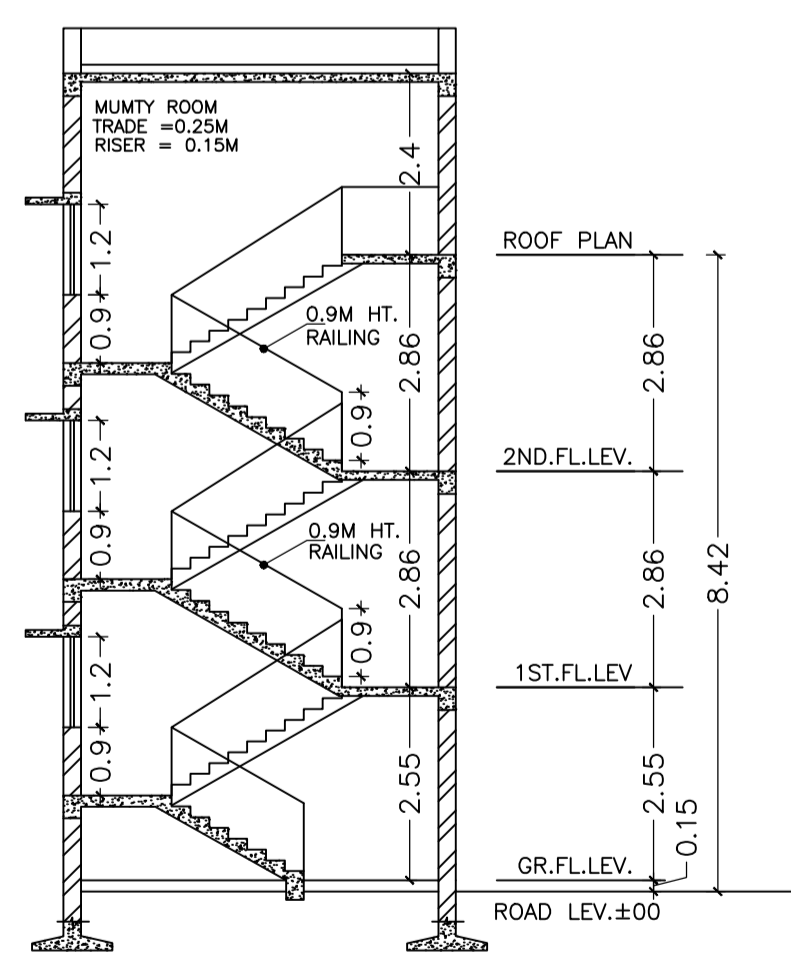

SECTION - X-X  
SCALE=1:100

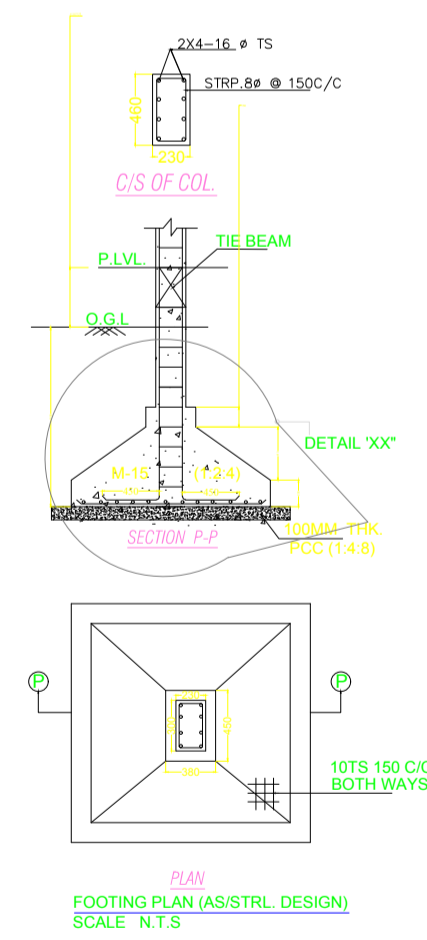

FOOTING PLAN (AS/STR.) DESIGN  
SCALE=1:15

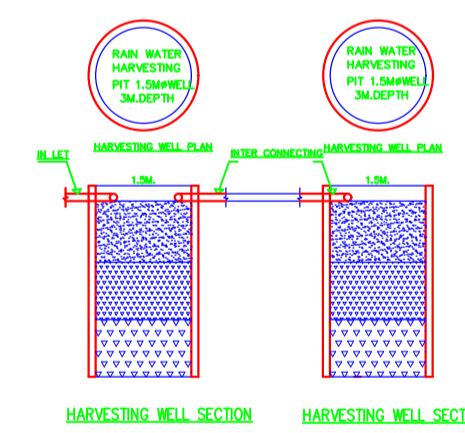

HARVESTING WELL SECTION

LTP NAME AND SIGNATURE	STRUCTURAL ENG'S NAME AND SIGNATURE	BUILDER NAME AND SIGNATURE	DIGITAL SIGNATURE
SHREYASHI PAUL JNAC/DFTMN/0009/2016			