

Proposal Basic Information

Proposal File No.	JNAC/BP/008/W12/2021
Owner Name	IBRAHIM HUSSAIN
Khata No	61
Plot No	2519
Village Name	SAKCHI
Use	Residential
SubUse	Bungalow/ Dwelling / Non Apartment

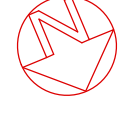
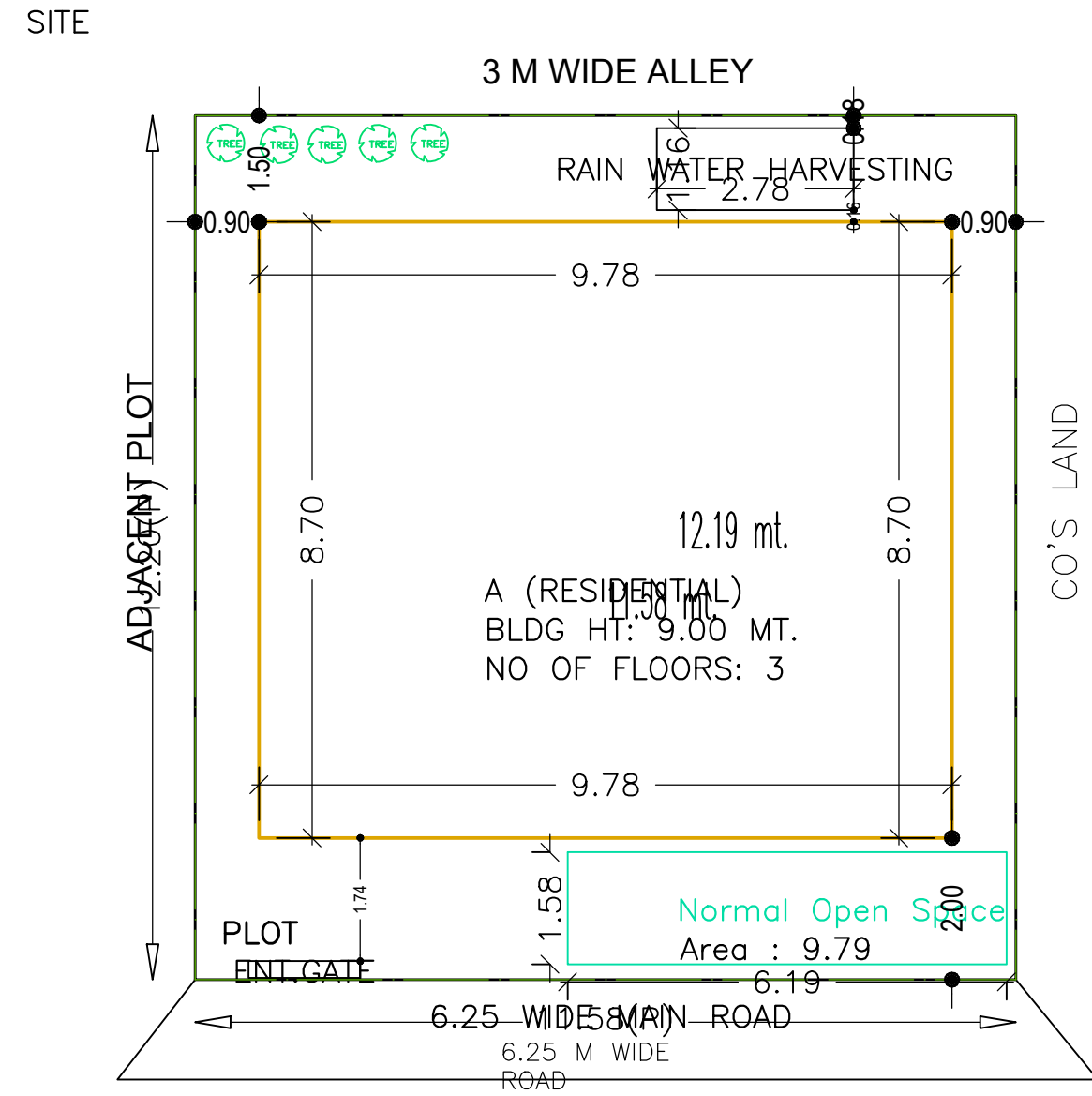

AREA STATEMENT	VERSION NO.: 1.0.61		
JAMSHEDPUR NAC	VERSION DATE: 16/10/2020		
PROJECT DETAIL:			
Region: JHARKHAND URBAN LOCAL BODIES	Plot Use: Residential		
District: EAST SINGHBHUM	Plot SubUse: Bungalow/ Dwelling / Non Apartment		
Authority: JAMSHEDPUR NAC	Plot/Nearby/Religious/Structure: NA		
Inward No: JNAC/BP/008/W12/2021	Plot/SubPlot No: 2519		
Application Type: General Proposal	North: -		
Project Type: Building Permission	South: -		
Nature of Development: New	East: -		
Location of Development Area: Old Area	West: -		
AREA DETAILS:			
AREA OF PLOT (Minimum)	(A)	SQ.MT.	141.22
NET AREA OF PLOT(Gross Plot Area - Deduction from Gross Plot area)	(A-Deductions)		141.22
Deduction for Balance Plot Area(from Gross Plot Area)			
Common Plot			9.79
Total			9.79
BALANCE AREA OF PLOT(Net Plot Area - Recreational/Amenity space)	(A-Deductions)		131.43
PLOT AREA FOR COVERAGE(Net Plot Area)	(A-Deductions)		141.22
Plot Area for FAR (Net Plot Area + Road/Widening Area)	(A-Deductions)		141.22
COVERAGE CHECK			
Permissible Coverage area ( 70.00 % )			98.85
Proposed Coverage Area ( 60.22 % )			85.04
Total Prop. Coverage Area ( 60.22 % )			85.04
Balance coverage area ( 9.78 % )			13.81
FAR CHECK			
Perm. FAR Area ( 2.50 )			353.05
Total Perm. FAR area			353.05
Residential FAR			189.87
Proposed FAR Area			189.87
Total Proposed FAR Area			189.87
Consumed FAR (Factor)			1.34
Balance FAR Area			163.18
BUILT UP AREA CHECK			
Total Proposed BuiltUp Area			255.11
ARCHITECT (Regd)		Amarjeet Balmuchu	
ENGINEER (Regd)			
SUPERVISOR (Regd)			
OWNER (Regd)		IBRAHIM HUSSAIN	
DEVELOPMENT AUTHORITY		LOCAL BODY	

COLOR INDEX	
PLOT BOUNDARY	
ABUTTING ROAD	
PROPOSED CONSTRUCTION	
COMMON PLOT	
ROAD WIDENING AREA	
EXISTING (To be retained)	
EXISTING (To be demolished)	

Buildingwise Floor FAR Details

Floor Name	Building Name A (RESIDENTIAL)		Total	
	Proposed Built Up Area (Sq.mt.)	Proposed FAR Area (Sq.mt.)	Total Proposed Built Up Area (Sq.mt.)	Total FAR Area (Sq.mt.)
Ground Floor	85.03	19.79	85.03	19.79
First Floor	85.04	85.04	85.04	85.04
Second Floor	85.04	85.04	85.04	85.04
Terrace Floor	0.00	0.00	0.00	0.00
Total :	255.11	189.87	255.11	189.87

Building USE/SUBUSE Details

Building Name	Building Use	Building SubUse	Building Structure
A (RESIDENTIAL)	Residential	Bungalow/ Dwelling / Non Apartment	Non-Highrise

FAR & Tenement Details (Table 4c-1)

Building	No. of Same Bldg	Total Built Up Area (Sq.mt.)	Deductions (Area in Sq.mt.)		Proposed FAR Area (Sq.mt.)	Total FAR Area (Sq.mt.)	Total Consumed FAR Area (Sq.mt.)	Trmt (No.)
			Parking	Resi.				
A (RESIDENTIAL)	1	255.11	65.24	189.87	189.87	189.87	01	
Grand Total :	1	255.11	65.24	189.87	189.87	189.87	01	

LTP NAME AND SIGNATURE	STRUCTURAL ENG'S NAME AND SIGNATURE	BUILDER NAME AND SIGNATURE	DIGITAL SIGNATURE
Amarjeet Balmuchu JNAC/ARC/0008/2018			

Proposal Basic Information

Proposal File No.	JNAC/BP/008/W12/2021
Owner Name	IBRAHIM HUSSAIN
Khata No	61
Plot No	2519
Village Name	SAKCHI
Use	Residential
SubUse	Bungalow/ Dwelling / Non Apartment

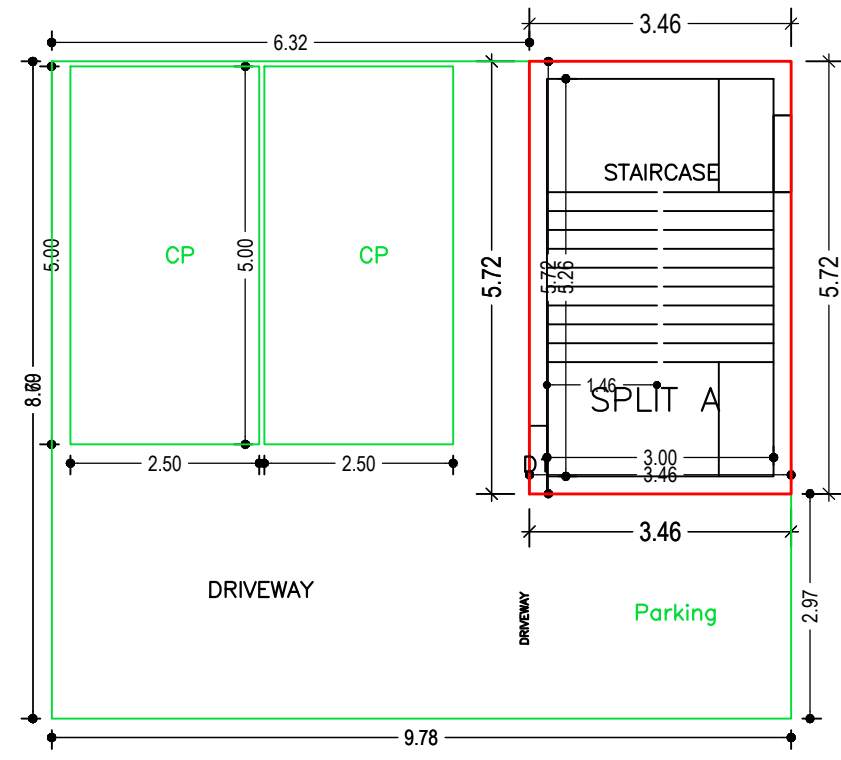

GROUND FLOOR PLAN  
(Proposed)  
(SCALE 1:100)

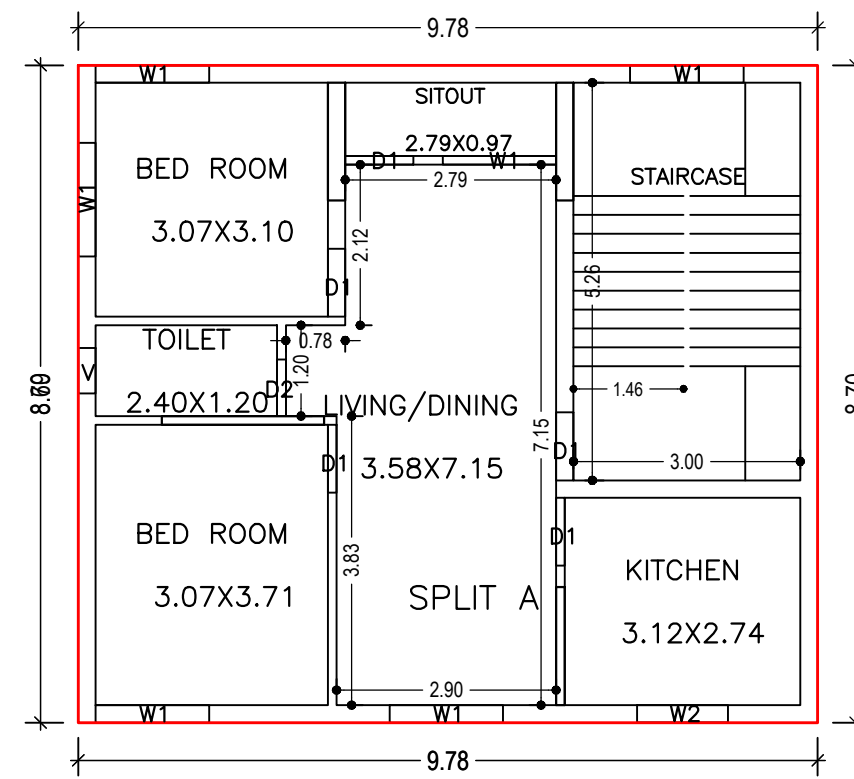

TYPICAL - 1, 2 FLOOR PLAN  
(Proposed)  
(SCALE 1:100)

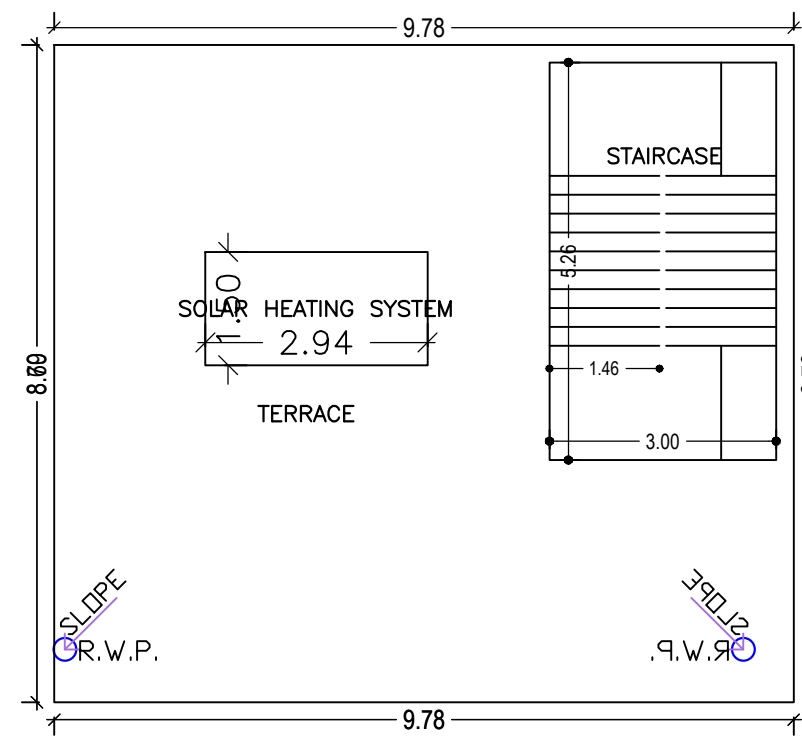

TERRACE FLOOR PLAN  
(SCALE 1:100)

Building :A (RESIDENTIAL)

Floor Name	Total Built Up Area (Sq.mt.)	Deductions (Area in Sq.mt.)	Proposed FAR Area (Sq.mt.)	Total FAR Area (Sq.mt.)	Total Consumed Additional FAR Area (Sq.mt.)	Tnmt (No.)
Ground Floor	85.03	65.24	19.79	19.79	19.79	01
First Floor	85.04	0.00	85.04	85.04	85.04	00
Second Floor	85.04	0.00	85.04	85.04	85.04	00
Terrace Floor	0.00	0.00	0.00	0.00	0.00	00
Total :	255.11	65.24	189.87	189.87	189.87	01
Total Number of Same Buildings :	1					
Total :	255.11	65.24	189.87	189.87	189.87	01

SCHEDULE OF DOOR:

BUILDING NAME	NAME	LENGTH	HEIGHT	NOS
A (RESIDENTIAL)	D2	0.75	2.10	02
A (RESIDENTIAL)	D1	0.90	2.10	10

SCHEDULE OF WINDOW/VENTILATION:

BUILDING NAME	NAME	LENGTH	HEIGHT	NOS
A (RESIDENTIAL)	V	0.60	1.20	02
A (RESIDENTIAL)	W2	1.20	1.20	02
A (RESIDENTIAL)	W1	1.50	1.20	12

UnitBUA Table for Building :A (RESIDENTIAL)

FLOOR	Name	UnitBUA Type	UnitBUA Area	Carpet Area	No. of Rooms	No. of Tenement
GROUND FLOOR PLAN	SPLIT A	FLAT	185.87	183.35	0	1
TYPICAL - 1, 2 FLOOR PLAN	SPLIT A	FLAT	0.00	0.00	6	0
Total:	-	-	185.87	183.35	12	1

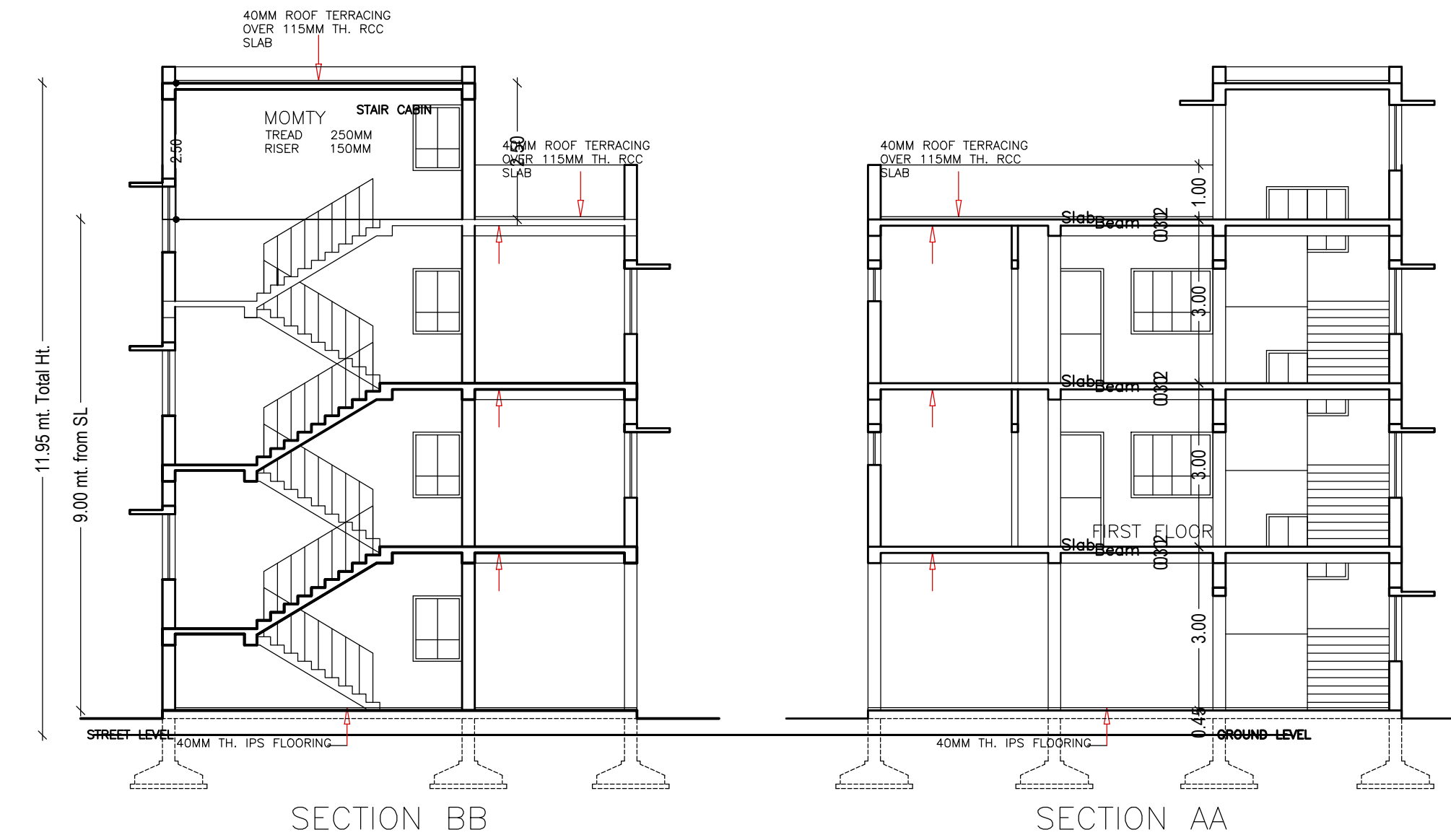

LTP NAME AND SIGNATURE	STRUCTURAL ENG'S NAME AND SIGNATURE	BUILDER NAME AND SIGNATURE	DIGITAL SIGNATURE
Amarjeet Balmuchu JNAC/ARC/0008/2018			

Proposal Basic Information

Proposal File No.	JNAC/BP/008/W12/2021
Owner Name	IBRAHIM HUSSAIN
Khata No	61
Plot No	2519
Village Name	SAKCHI
Use	Residential
SubUse	Bungalow/ Dwelling / Non Apartment

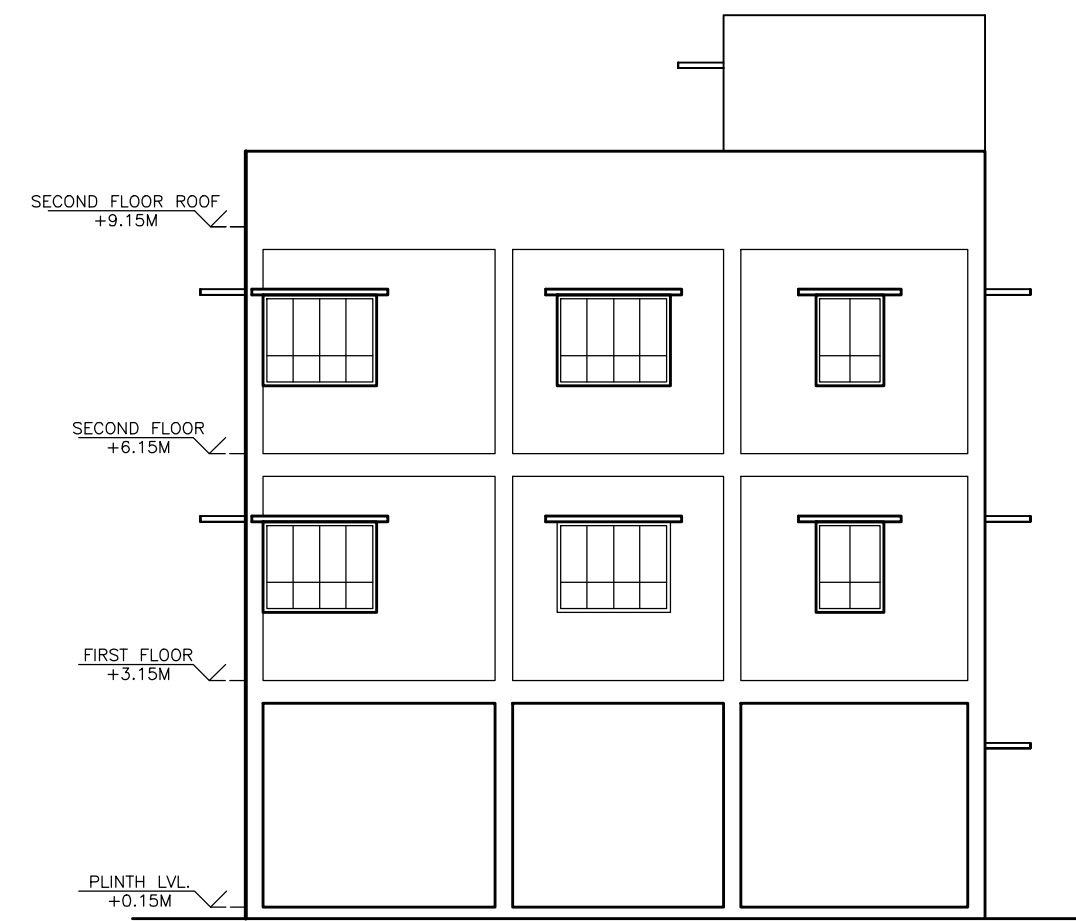
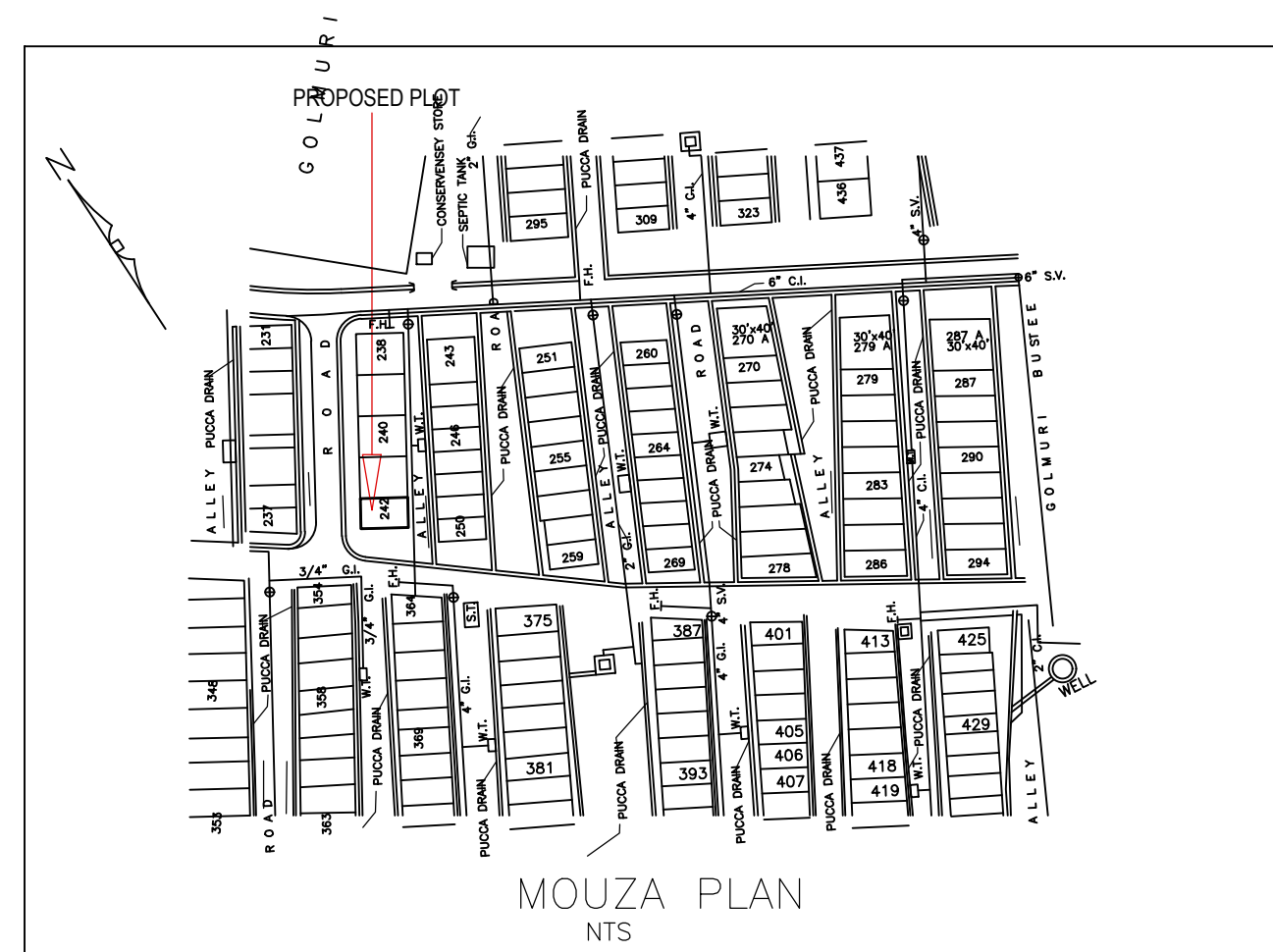

FRONT ELEVATION

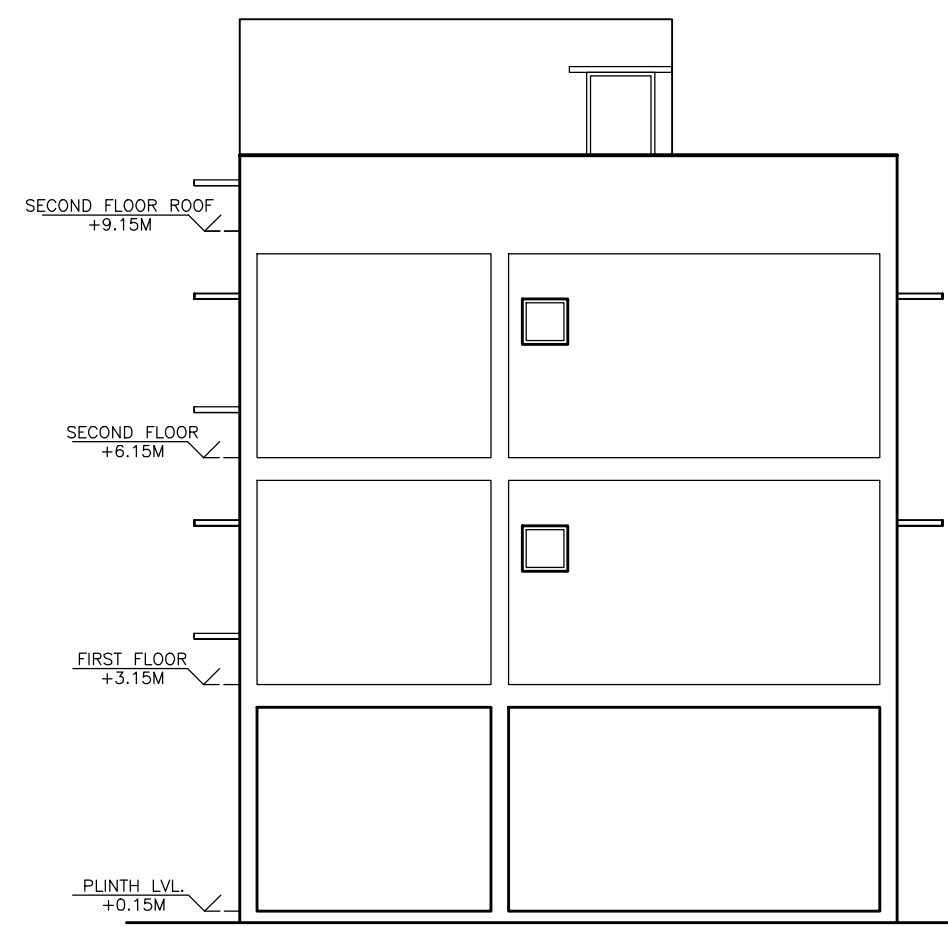

SIDE ELEVATION

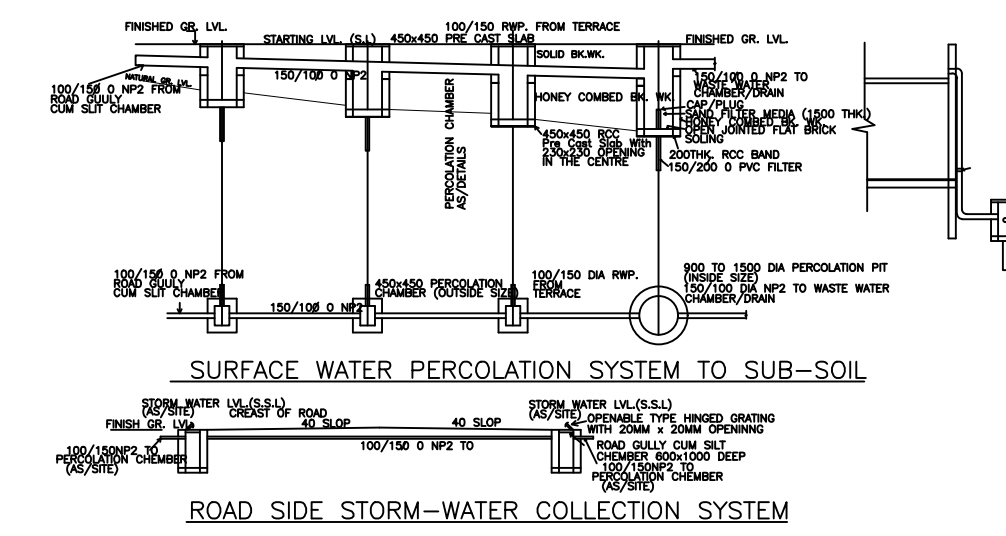
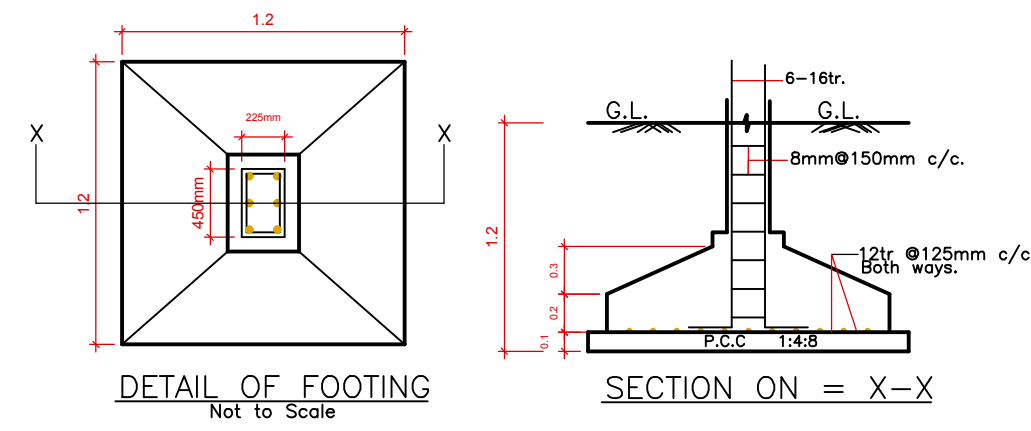

LTP NAME AND SIGNATURE	STRUCTURAL ENG'S NAME AND SIGNATURE	BUILDER NAME AND SIGNATURE	DIGITAL SIGNATURE
Amarjeet Balmuchu JNAC/ARC/008/2018			