

Proposal Basic Information	
Proposal File No.	JNAC/BP/0093/W1/2021
Owner Name	SIRIL KUJUR SAROJINI ANJLINA BARA ANJU KUJUR NISHIT KUJUR
Khata No	622
Plot No	5969
Village Name	SONARI
Use	Residential
SubUse	Bungalow/ Dwelling / Non Apartment

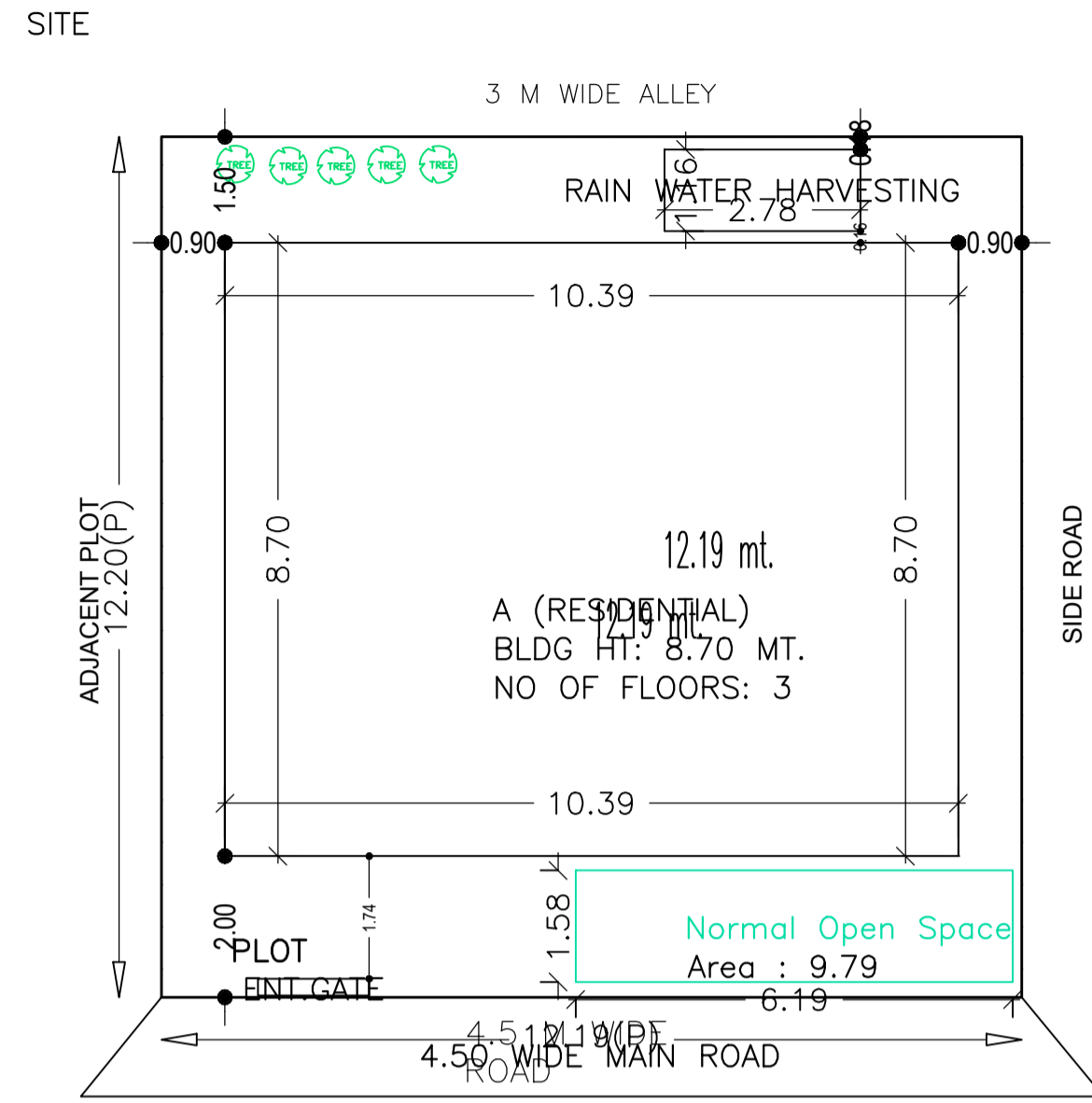

SITE PLAN  
SCALE - 1:150

COLOR INDEX	
PLOT BOUNDARY	[Red Line]
ABUTTING ROAD	[Green Line]
PROPOSED CONSTRUCTION	[Blue Line]
COMMON PLOT	[Yellow Line]
ROAD WIDENING AREA	[Orange Line]
EXISTING (To be retained)	[Purple Line]
EXISTING (To be demolished)	[Pink Line]

Floor Name	Building Name A (RESIDENTIAL)		Total	
	Proposed Built Up Area (Sq.mt.)	Proposed FAR Area (Sq.mt.)	Total Proposed Built Up Area (Sq.mt.)	Total FAR Area (Sq.mt.)
Ground Floor	90.38	19.79	90.38	19.79
First Floor	90.38	90.38	90.38	90.38
Second Floor	90.38	90.38	90.38	90.38
Terrace Floor	0.00	0.00	0.00	0.00
Total :	271.14	200.55	271.14	200.55

Building USE/SUBUSE Details			
Building Name	Building Use	Building SubUse	Building Structure
A (RESIDENTIAL)	Residential	Bungalow/ Dwelling / Non Apartment	Non-Highrise

FAR & Tenement Details (Table 4c-1)								
Building	No. of Same Bldg	Total Built Up Area (Sq.mt.)	Deductions (Area in Sq.mt.)		Proposed FAR Area (Sq.mt.)	Total FAR Area (Sq.mt.)	Total Consumed Additional FAR Area (Sq.mt.)	Tmnt (No.)
			Parking	Resi.				
A (RESIDENTIAL)	1	271.14	70.59	200.55	200.55	200.55	01	
Grand Total :	1	271.14	70.59	200.55	200.55	200.55	01	

AREA STATEMENT		VERSION NO.: 1.0.61
JAMSHEDPUR NAC		VERSION DATE: 16/10/2020
<b>PROJECT DETAIL:</b>		
Region: JHARKHAND URBAN LOCAL BODIES	Plot Use: Residential	
District: EAST SINGHBHUM	Plot SubUse: Bungalow/ Dwelling / Non Apartment	
Authority: JAMSHEDPUR NAC	PlotNearbyReligiousStructure: NA	
Inward No: JNAC/BP/0093/W1/2021	Plot/SubPlot No: 5969	
Application Type: General Proposal	North: -	
Project Type: Building Permission	South: -	
Nature of Development: New	East: -	
Location of Development Area: Old Area	West: -	
<b>AREA DETAILS:</b>		
AREA OF PLOT (Minimum)	(A)	SQ.MT. 148.72
NET AREA OF PLOT (Gross Plot Area - Deduction from Gross Plot area)	(A-Deductions)	148.72
Deduction for Balance Plot Area (from Gross Plot Area)		
Common Plot		9.79
Total		9.79
BALANCE AREA OF PLOT (Net Plot Area - Recreational/Amenity space)	(A-Deductions)	138.93
PLOT AREA FOR COVERAGE (Net Plot Area)	(A-Deductions)	148.72
Plot Area for FAR (Net Plot Area + Road Widening Area)	(A-Deductions)	148.72
<b>COVERAGE CHECK</b>		
Permissible Coverage area ( 70.00 % )		104.10
Proposed Coverage Area ( 60.77 % )		90.38
Total Prop. Coverage Area ( 60.77 % )		90.38
Balance coverage area ( 9.23 % )		13.72
<b>FAR CHECK</b>		
Perm. FAR Area ( 1.50 )		223.08
Total Perm. FAR area		223.08
Residential FAR		200.56
Proposed FAR Area		200.56
Total Proposed FAR Area		200.56
Consumed FAR (Factor)		1.35
Balance FAR Area		22.52
<b>BUILT UP AREA CHECK</b>		
Total Proposed BuiltUp Area		271.14
ARCHITECT (Regd)	Amarjeet Balmuchu	
ENGINEER (Regd)		
SUPERVISOR (Regd)		
OWNER (Regd)	SIRIL KUJUR SAROJINI ANJLINA BARA ANJU KUJUR NISHIT KUJUR	
DEVELOPMENT AUTHORITY	LOCAL BODY	

LTP NAME AND SIGNATURE	STRUCTURAL ENG'S NAME AND SIGNATURE	BUILDER NAME AND SIGNATURE	DIGITAL SIGNATURE
Amarjeet Balmuchu JNAC/ARC/0008/2018			

Proposal Basic Information	
Proposal File No.	JNAC/BP/0093/W1/2021
Owner Name	SIRIL KUJUR SAROJINI ANJLINA BARA ANJU KUJUR NI KUJUR
Khata No	622
Plot No	5969
Village Name	SONARI
Use	Residential
SubUse	Bungalow/ Dwelling / Non Apartment

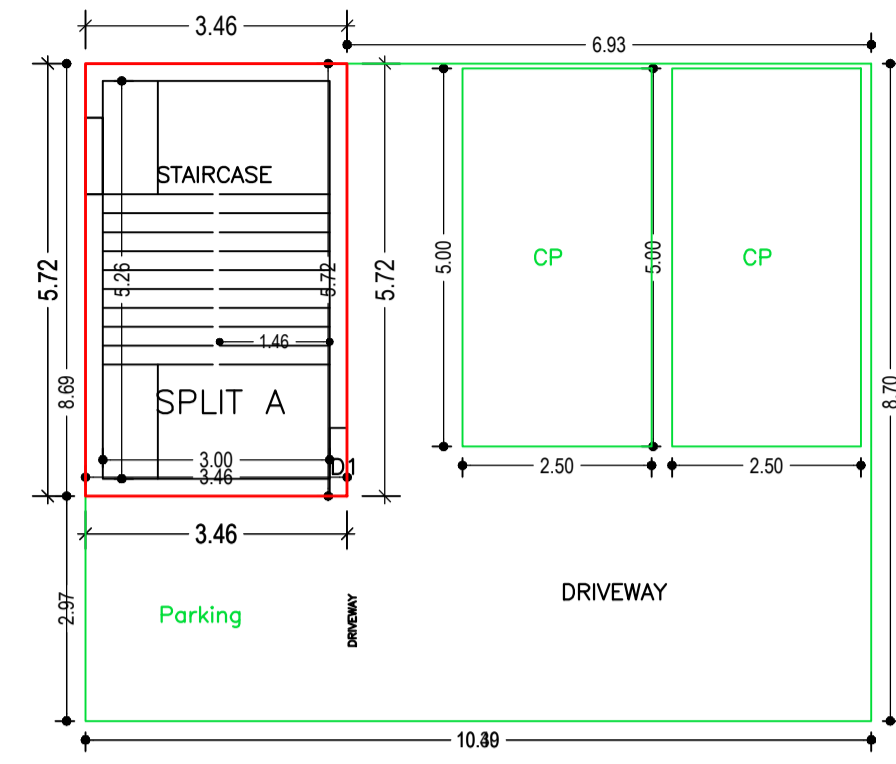

GROUND FLOOR PLAN  
(Proposed)  
(SCALE 1:100)

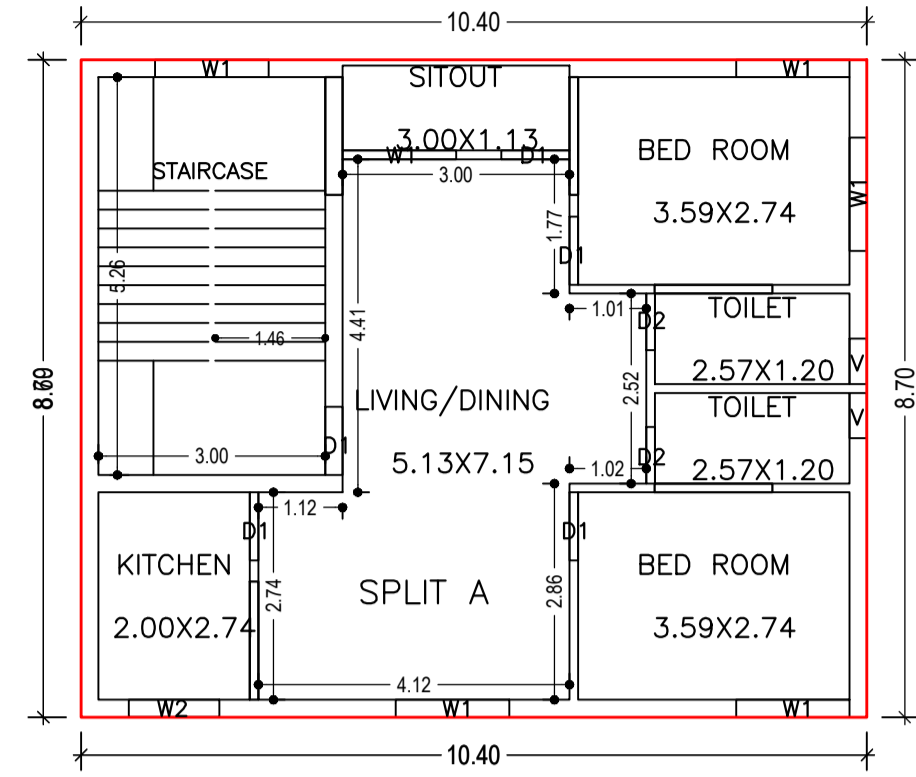

TYPICAL - 1, 2 FLOOR PLAN  
(Proposed)  
(SCALE 1:100)

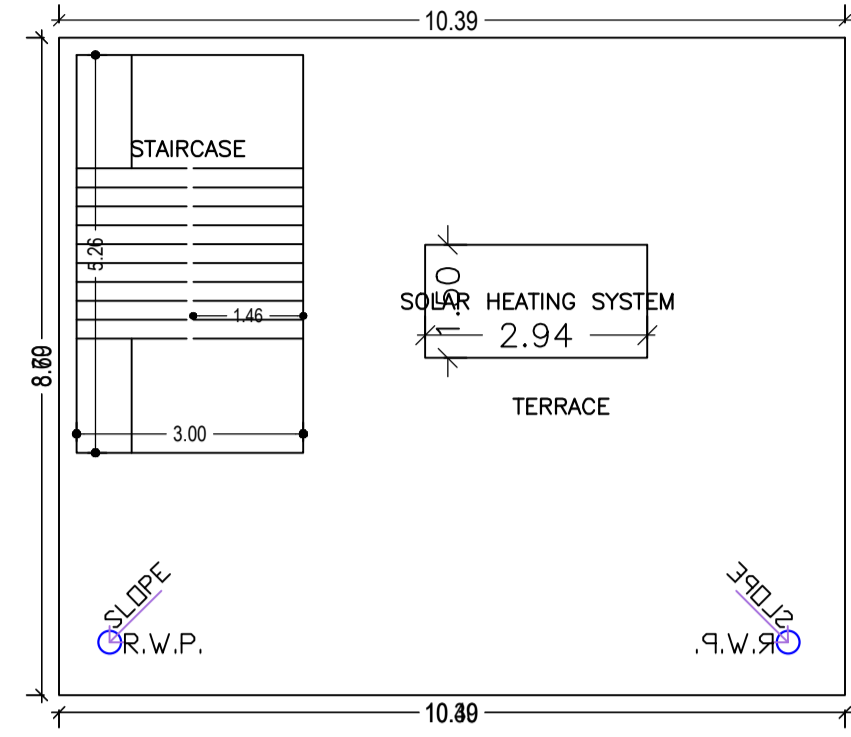

TERRACE FLOOR PLAN  
(SCALE 1:100)

Building :A (RESIDENTIAL)

Floor Name	Total Built Up Area (Sq.mt.)	Deductions (Area in Sq.mt.)		Proposed FAR Area (Sq.mt.)	Total FAR Area (Sq.mt.)	Total Consumed Additional FAR Area (Sq.mt.)	Tnmt (No.)
		Parking	Resi.				
Ground Floor	90.38	70.59	19.79	19.79	19.79	19.79	01
First Floor	90.38	0.00	90.38	90.38	90.38	90.38	00
Second Floor	90.38	0.00	90.38	90.38	90.38	90.38	00
Terrace Floor	0.00	0.00	0.00	0.00	0.00	0.00	00
Total :	271.14	70.59	200.55	200.55	200.55	200.55	01
Total Number of Same Buildings :	1						
Total :	271.14	70.59	200.55	200.55	200.55	200.55	01

SCHEDULE OF DOOR:

BUILDING NAME	NAME	LENGTH	HEIGHT	NOS
A (RESIDENTIAL)	D2	0.75	2.10	04
A (RESIDENTIAL)	D1	0.90	2.10	10

SCHEDULE OF WINDOW/VENTILATION:

BUILDING NAME	NAME	LENGTH	HEIGHT	NOS
A (RESIDENTIAL)	V	0.60	1.20	04
A (RESIDENTIAL)	W2	1.20	1.20	02
A (RESIDENTIAL)	W1	1.50	1.20	12

UnitBUA Table for Building :A (RESIDENTIAL)

FLOOR	Name	UnitBUA Type	UnitBUA Area	Carpet Area	No. of Rooms	No. of Tenement
GROUND FLOOR PLAN	SPLIT A	FLAT	196.56	194.18	0	1
TYPICAL - 1, 2 FLOOR PLAN	SPLIT A	FLAT	0.00	0.00	7	0
Total:	-	-	196.56	194.18	14	1

LTP NAME AND SIGNATURE	STRUCTURAL ENG'S NAME AND SIGNATURE	BUILDER NAME AND SIGNATURE	DIGITAL SIGNATURE
Amarjeet Balmuchu JNAC/ARC/0008/2018			



Proposal Basic Information

Proposal File No.	JNAC/BP/0093/W1/2021
Owner Name	SIRIL KUJUR SAROJINI ANJLINA BARA ANJU KUJUR NI KUJUR
Khata No	622
Plot No	5969
Village Name	SONARI
Use	Residential
SubUse	Bungalow/ Dwelling / Non Apartment

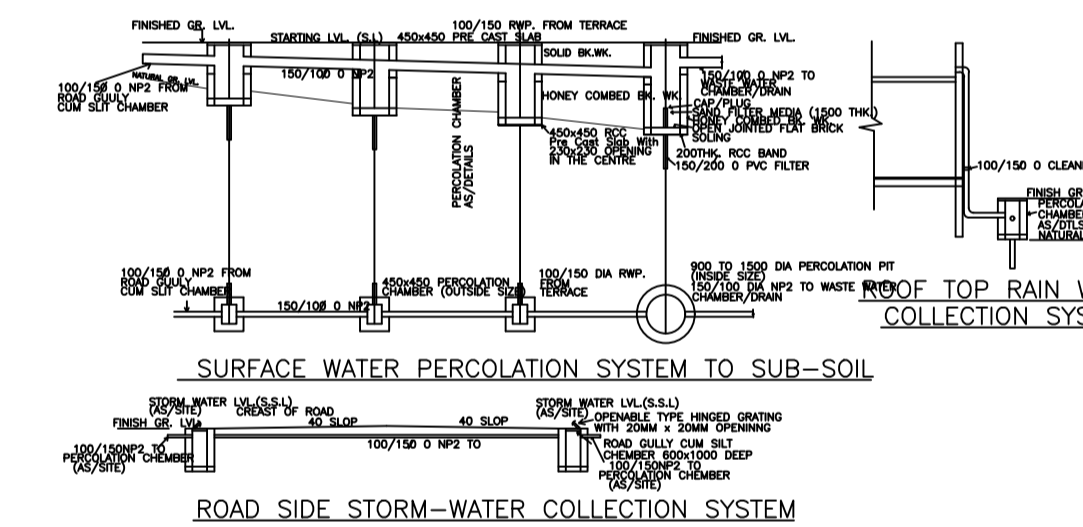
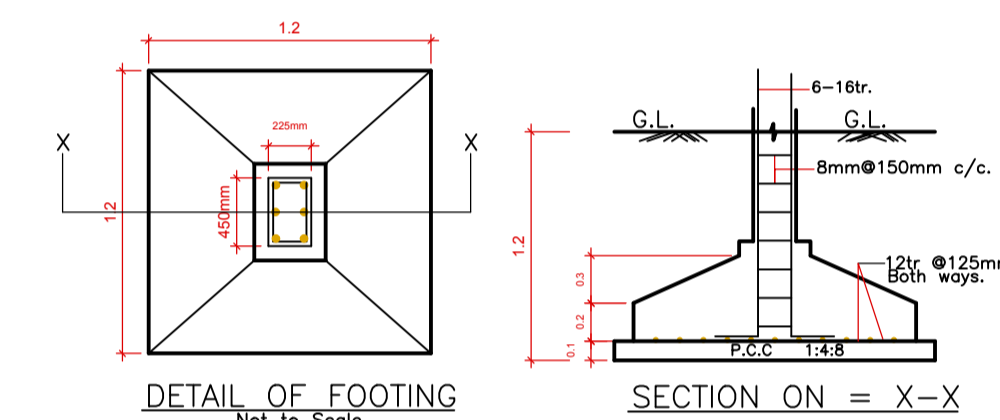
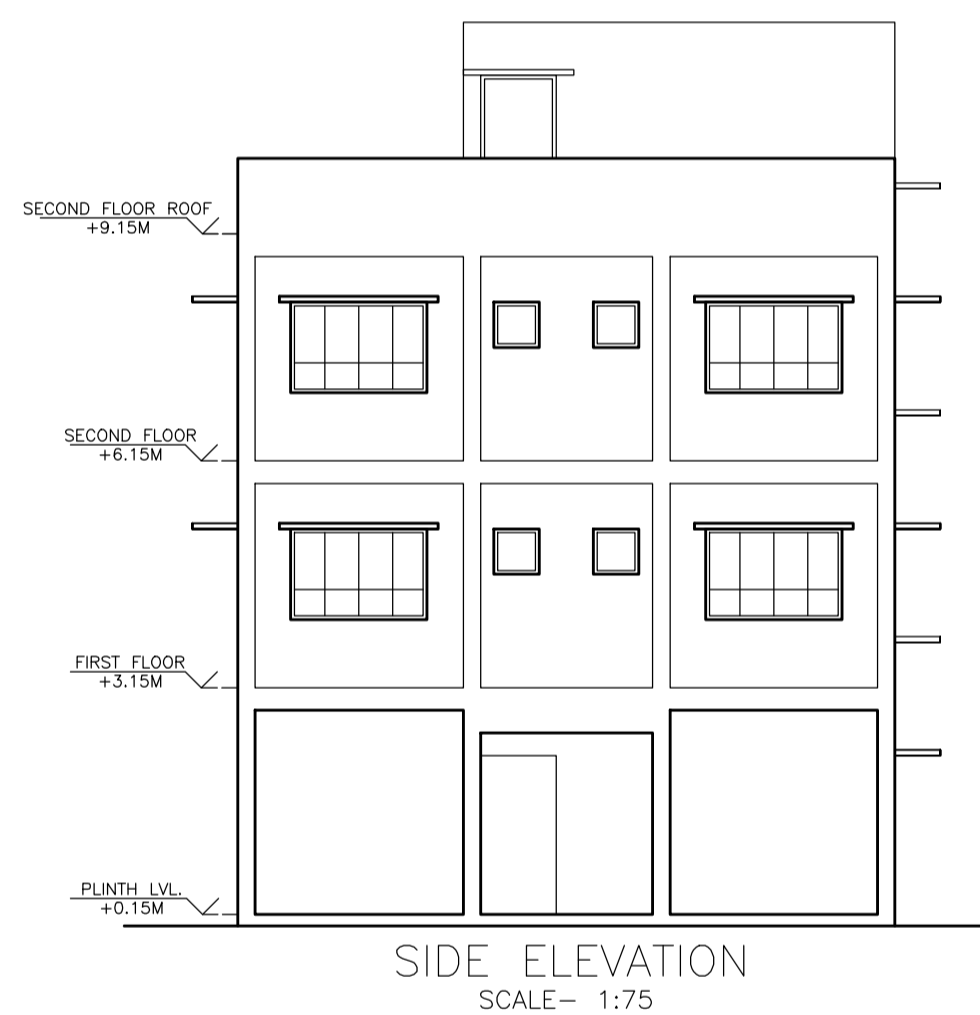
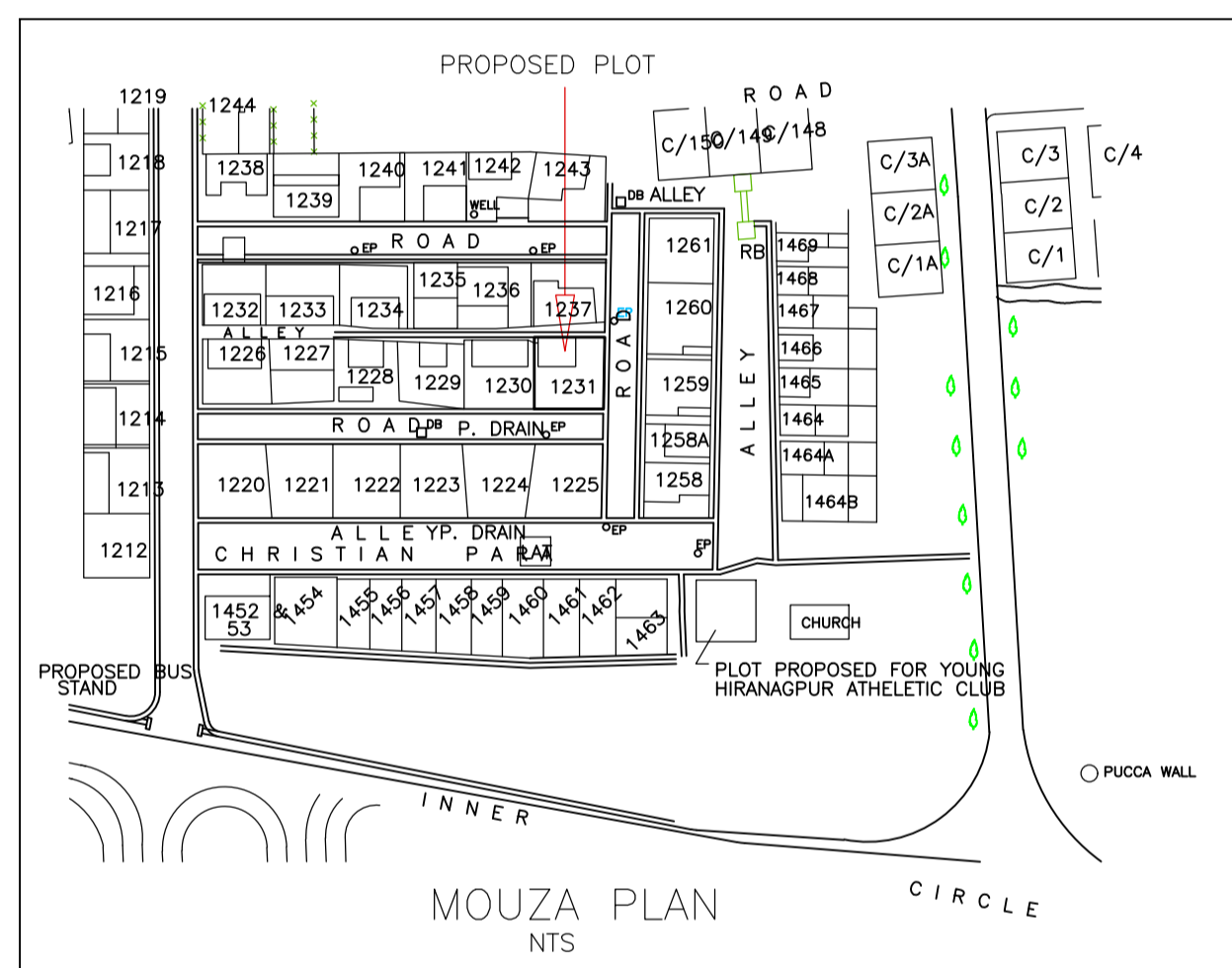
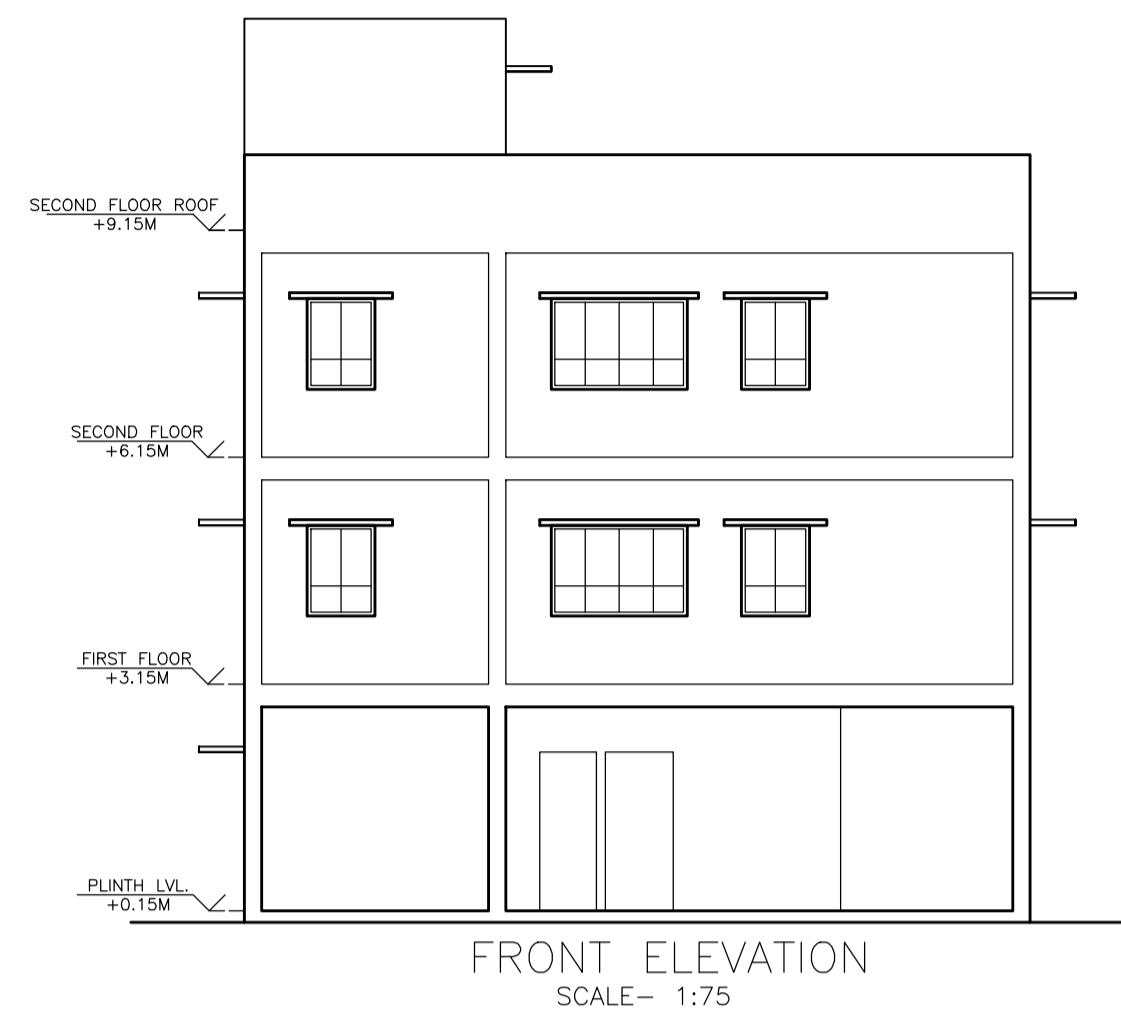
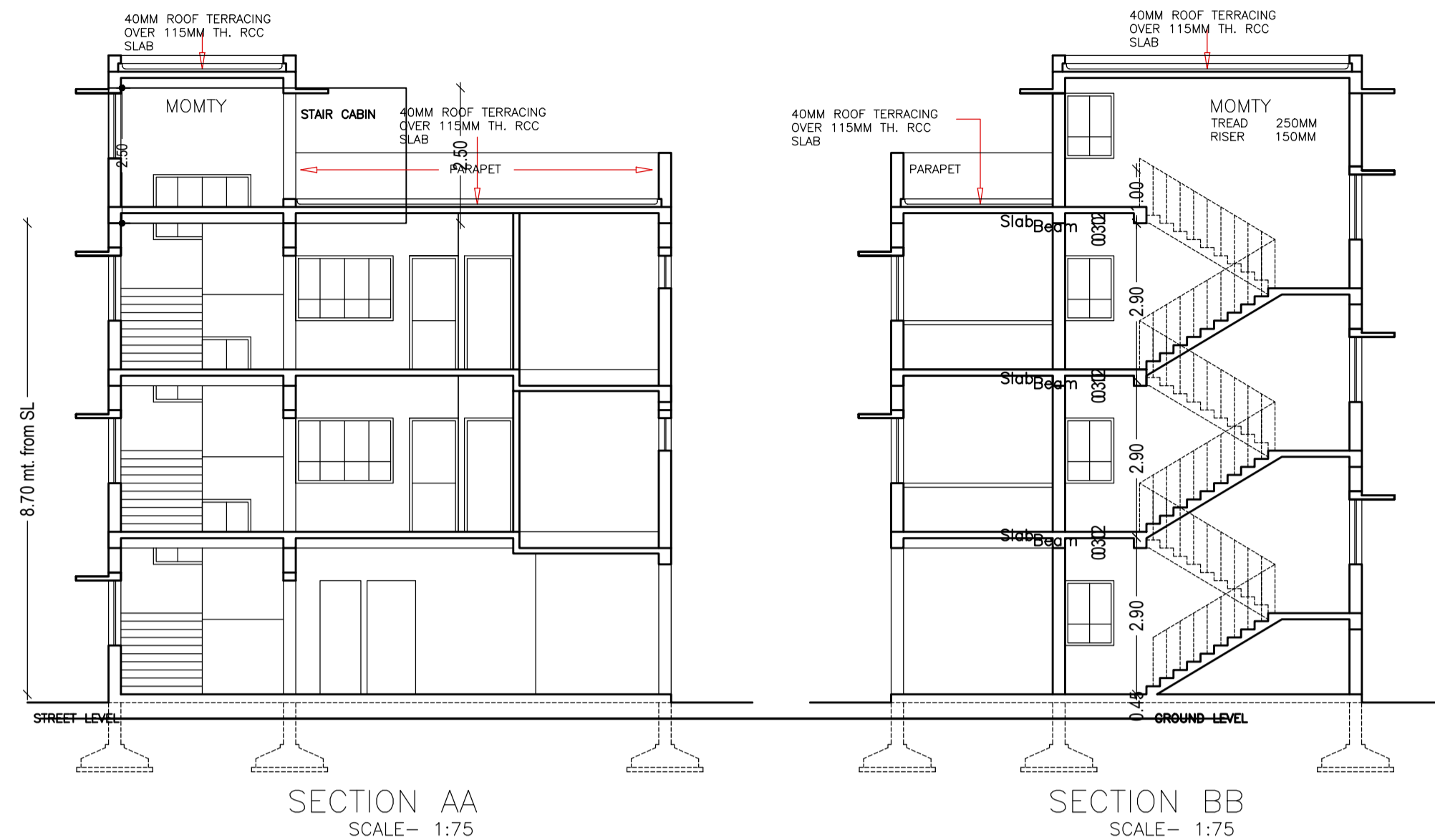

LTP NAME AND SIGNATURE	STRUCTURAL ENG'S NAME AND SIGNATURE	BUILDER NAME AND SIGNATURE	DIGITAL SIGNATURE
Amarjeet Balmuchu JNAC/ARC/0008/2018			