

STRUCTURAL DRAWINGS
RESIDENTIAL

OWNER:-

Sri BISHAKHA TIWARY

PLOT DETAILS:-

THANA NO. 1159,P.S SONARI,PARGANA
DHALBHUM, SINGHBHUM

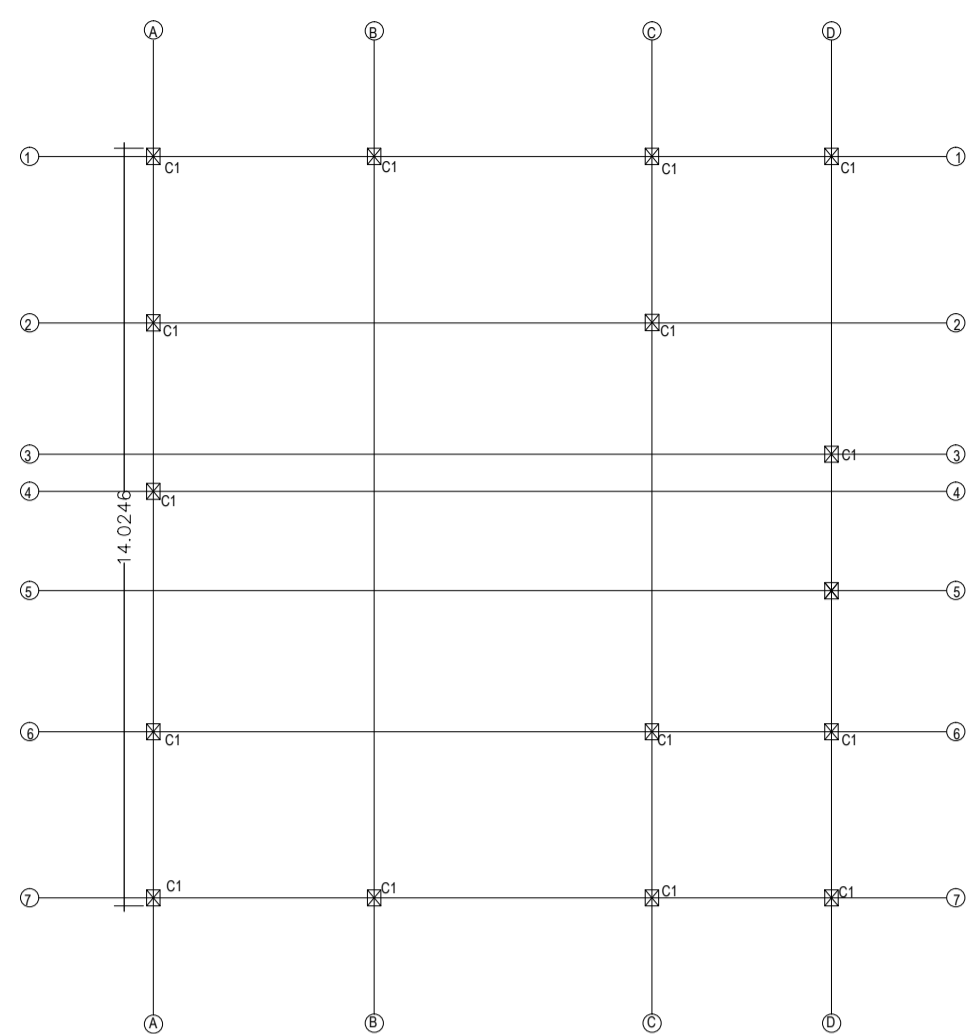

COLUMN CENTER LINE PLAN

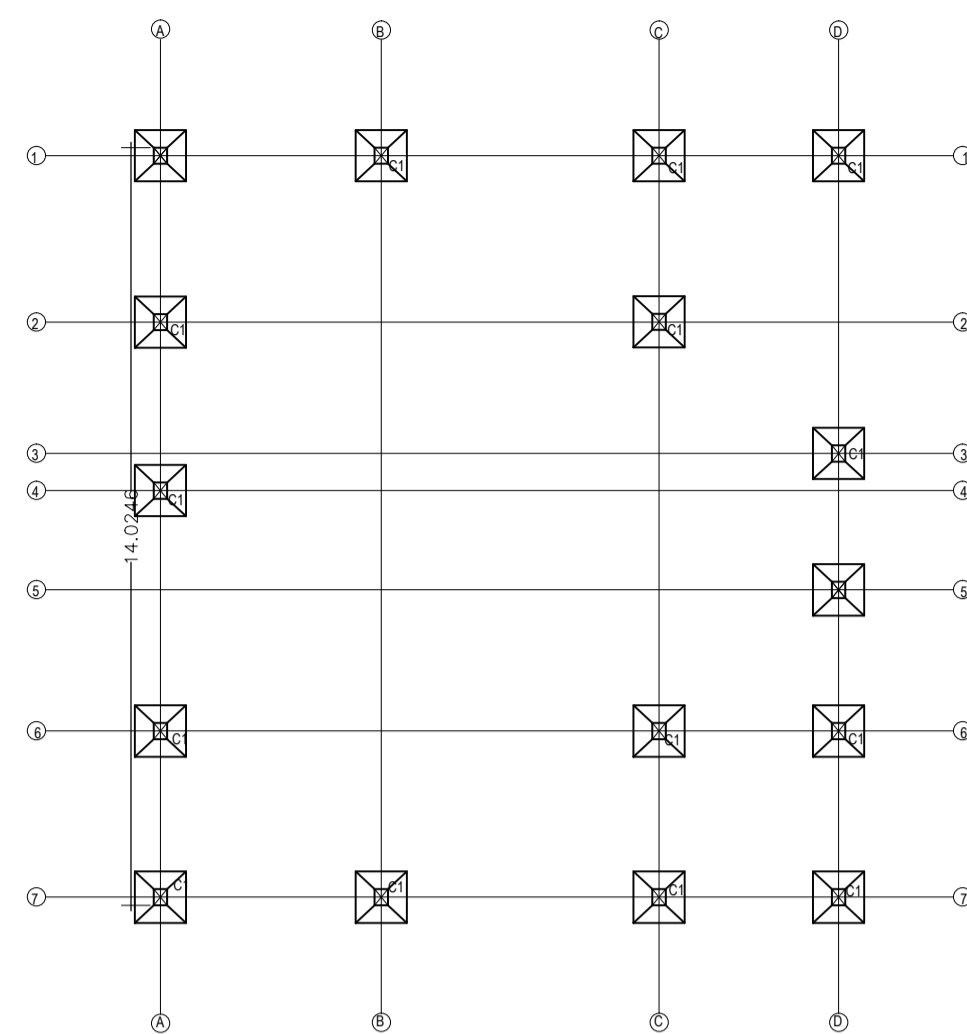

FOOTING PLAN

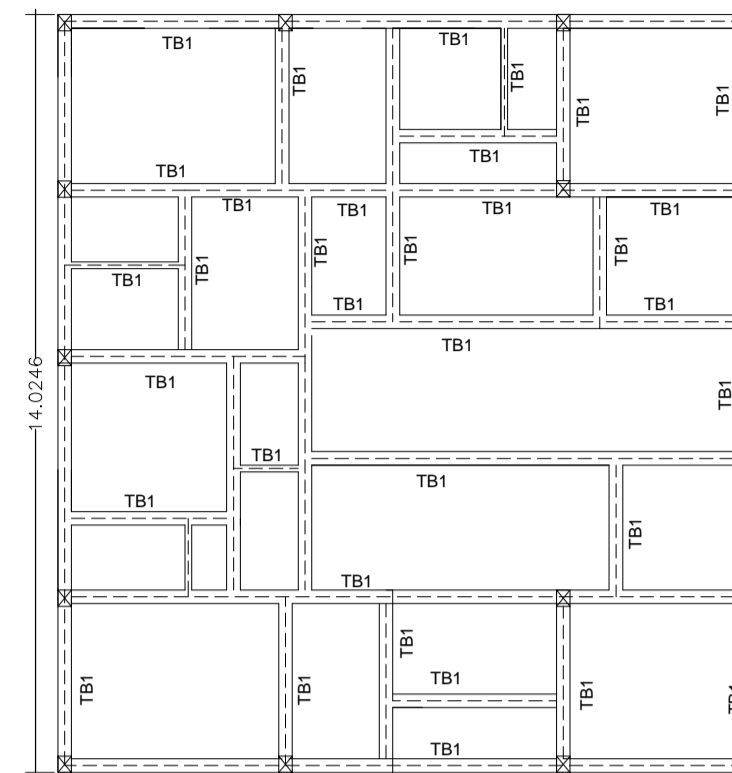

TIE BEAM LAYOUT PLAN

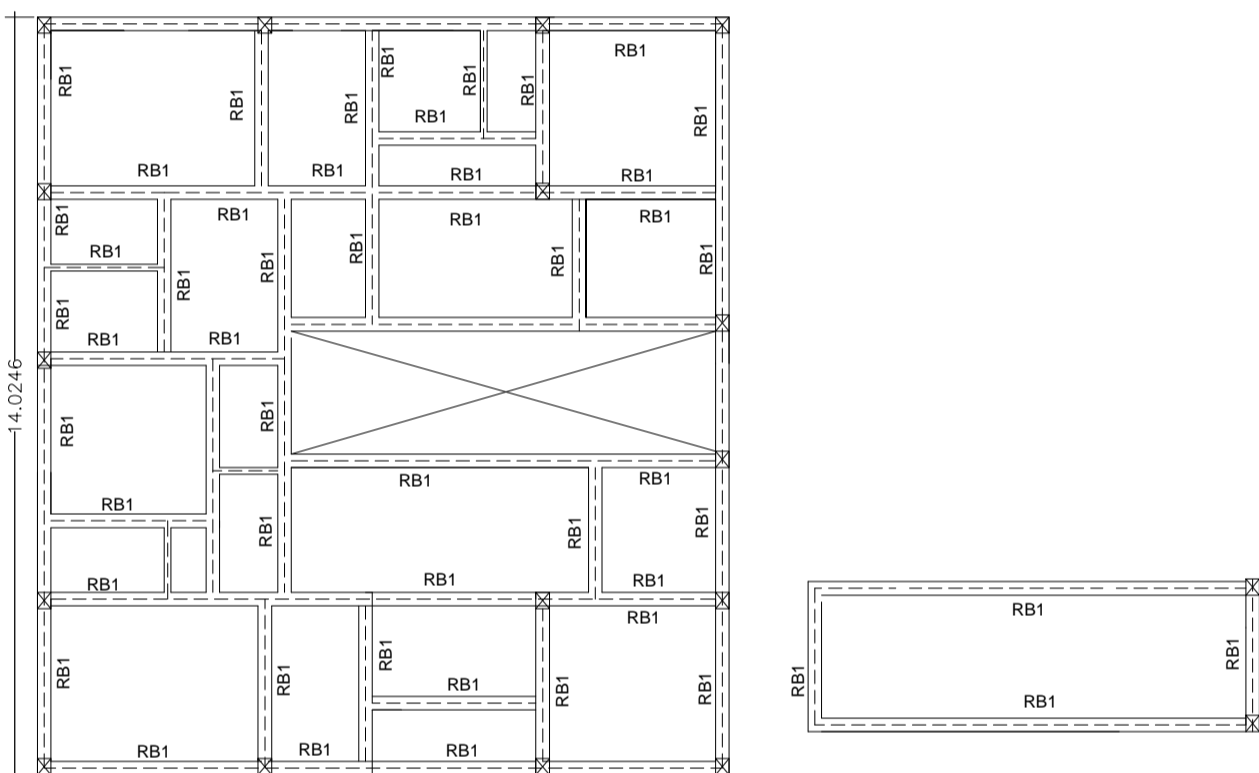

MUMTY ROOF BEAM LAYOUT PLAN

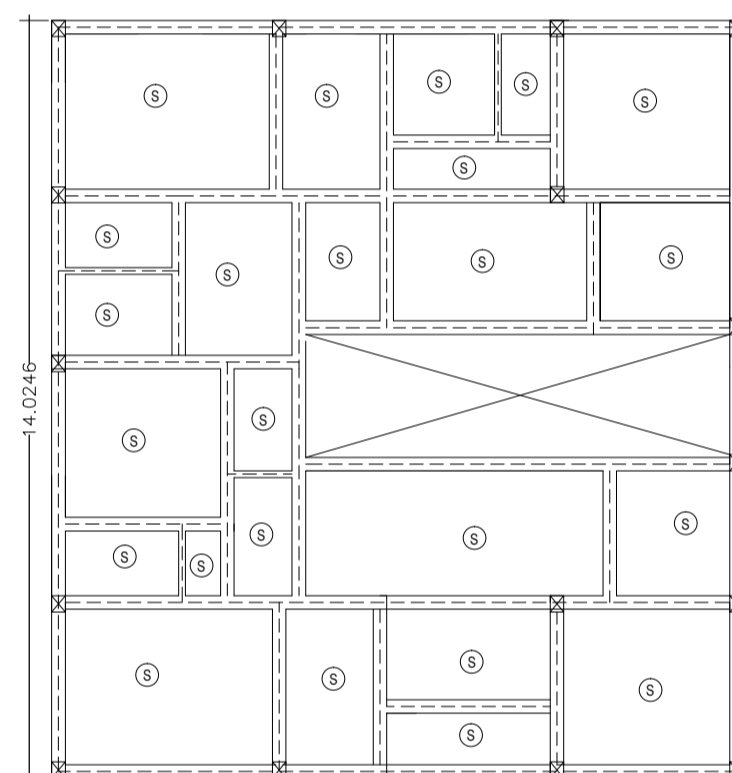

TYPICAL ROOF SLAB LAYOUT PLAN

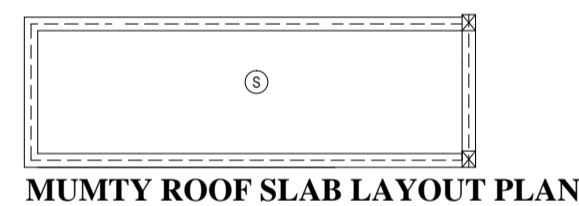

MUMTY ROOF SLAB LAYOUT PLAN

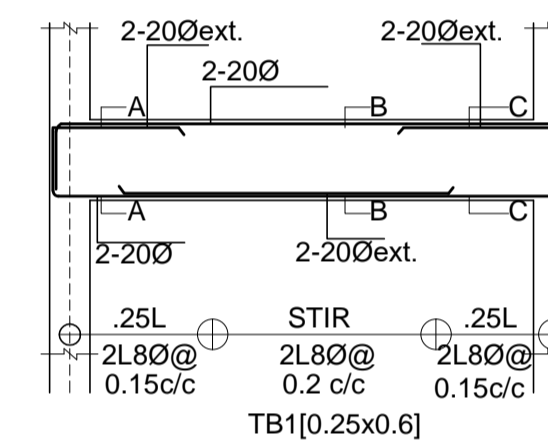
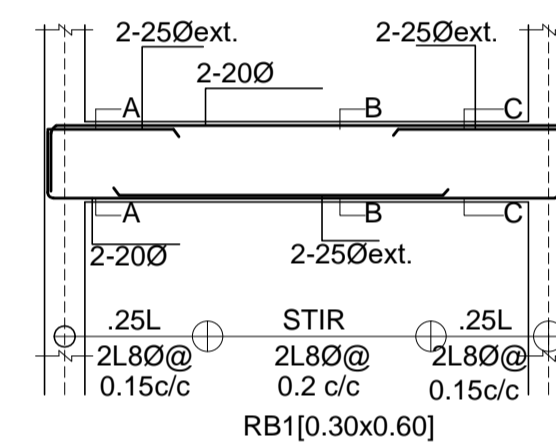

TYPICAL ROOF BEAM LAYOUT PLAN

COLUMN SCHEDULE			
COLUMN MKD.	COLUMN SIZE	REINFORCEMENT	STIRRUPS:
C1	0.25x0.6		8 Ø @0.150 C/C (2L)
C2	0.3x0.6		8 Ø @0.150 C/C (2L)

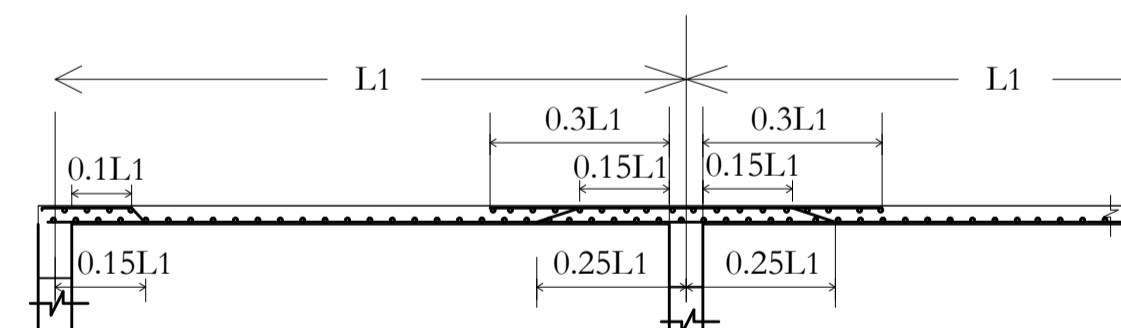

PANEL MKD & SLAB THK	REINFORCEMENT			
	AST AS SHORT	TOP AS SHORT	AST AS LONG	TOP AS LONG
S - 0.110	80@ 0.15 c/c	80@ 0.3 c/c CRND +80@ 0.3 c/c EXT	80@ 0.15 c/c	80@ 0.3 c/c CRND +80@ 0.3 c/c EXT

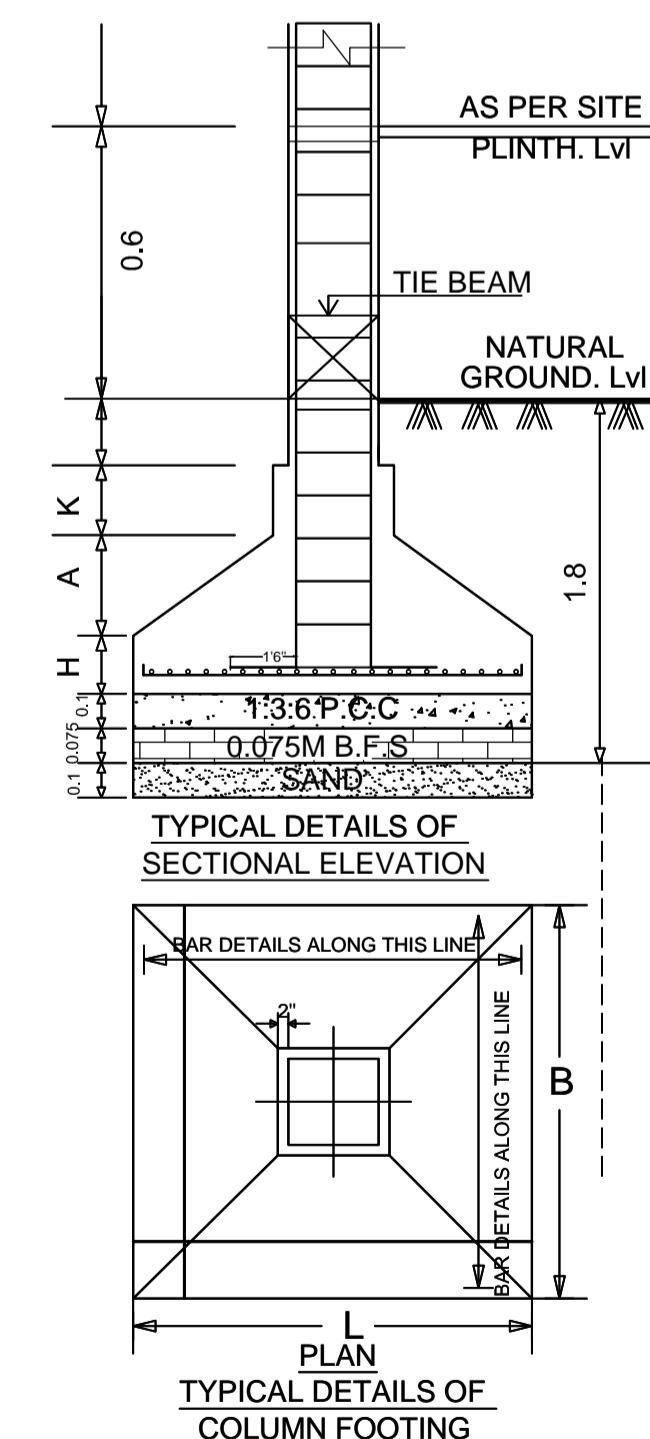
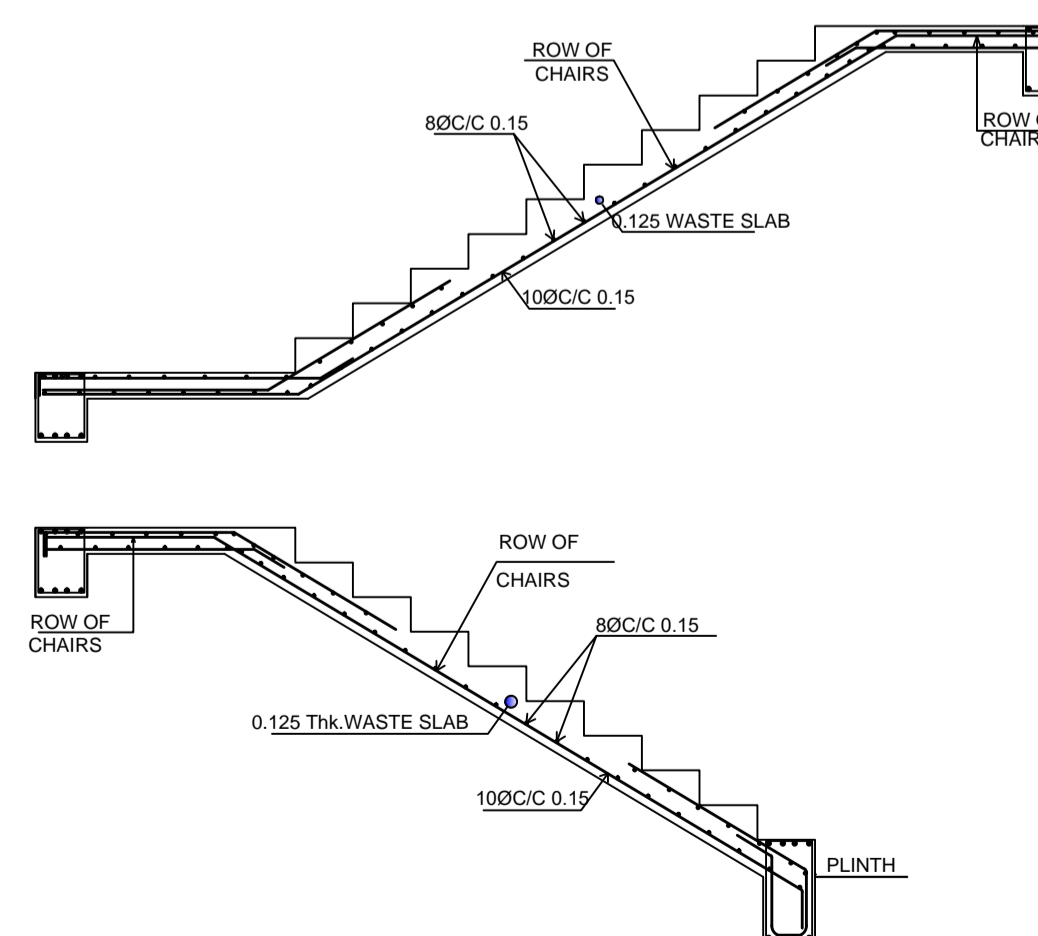

DOOR WINDOW AND VENTILATION DETAIL

No.	Symbol	Dimensions	Description
1.	D	1.06M X 2.13M	Pannelled t.w single shutter door.
2.	D1	0.91MX2.13M	Pannelled t.w single shutter door.
3.	D2	0.76MX2.13M	Pannelled t.w single shutter door.
4.	W	1.8MX1.2M	Glazed steel framed window 4. shutt.
5.	W1	0.6MX1.2M	Glazed steel framed window 3. shutt.
6.	W2	1.2MX1.2M	Glazed steel framed window 2. shutt.
7.	W3	0.91MX1.2M	Glazed steel framed window 2. shutt.
8.	V1	1.22MX0.61M	Top hung steel ventilator.
9.	V	0.61MX0.61M	Top hung steel ventilator.

Note- this detail is applicable in all floor.

GENERAL SPECIFICATIONS :-

- FOUNDATION :- P.C.C. 1:3:6 WITH BRICK WORK UP TO PLINTH LEVEL. (R.C.C. FOOTING AS/ STRL DTLS)
- D.P.C. :- 1" THK D.P.C. AT PLINTH LEVEL.
- SUPPER STRUCTURE :- BRICK WROK 0.229 & 0.114THK (1:6) LINTEL, CHAJJA, STAIR CASE AS/STRUCTURAL DETAILS.
- FLOORING :- 100mm THK CEMENT CONC. WITH 50mm THK L.P.S. FLOOR FINISH.
- ROOF :- 114mm THK. R.C.C. SLAB WITH AVERAGE 114mm THK. BRICK BATS, KHOA ON TOP.
- INNER FLOOR :- 0.152 THK. R.C.C. SLAB WITH 25mm THK. L.P.S. FLOOR, FINISH ON TOP.
- PLASTER :- 20mm THK. CEMENT PLASTER TO BE PROVIDED IN SIDE, AND OUT SIDE BUILDING.
- TOILET :- 1 LW.C SHOWERS, WASH BASINS ETC. WITH FIRST CLASS SANITARY FITTINGS & TO BE CONNECTED ROAD SEWER LINES
- DOOR :- SALWOOD FRAME WITH 1.5" THK. FLUSH OR PANNELLED SHUTTER
- WINDOW :- SALWOOD FRAME WITH FLUSH & PANNELLED & GLASSED SHUTTER MS GRIL TO BE PROVIDED AS/STRUCTURAL DETAILS

SIGNATURE OF OWNER :

Sri BALBINDER SINGH BEDI

SIGNATURE OF CONSULTANT

CHHAYA ARCHITECT & CONSULTANTS
Office : Third Floor , Taj Building, Sakchi
Jamshedpur.
M-9204013674 9234604901 223 3567

ENGINEER

OFFICER