

Proposal Basic Information

Proposal File No.	JNAC/BP/0106/W3/2022
Owner Name	MD SADIQUE HUSSIAN
Khata No	70 B BLOCK
Plot No	70 B BLOCK
Village Name	BELDIH
Use	Residential
SubUse	Bungalow/ Dwelling / Non Apartment

AREA STATEMENT	VERSION NO.: 1.0.74		
JAMSHEDPUR NAC	VERSION DATE: 16/10/2020		
PROJECT DETAIL:			
Region: JHARKHAND URBAN LOCAL BODIES	Plot Use: Residential		
District: EAST SINGHBHUM	Plot SubUse: Bungalow/ Dwelling / Non Apartment		
Authority: JAMSHEDPUR NAC	Plot/Nearby/Religious/Structure: NA		
Inward No: JNAC/BP/0106/W3/2022	Plot/SubPlot No: 70 B BLOCK		
Application Type: General Proposal	North: -		
Project Type: Building Permission	South: Road Width - 6.10		
Nature of Development: New	East: Road Width - 8.03		
Location of Development Area: Old Area	West: -		
AREA DETAILS:			
AREA OF PLOT (Minimum)	(A)	SQ.MT.	111.48
NET AREA OF PLOT (Gross Plot Area - Deduction from Gross Plot area)	(A-Deductions)		111.48
Deduction for Balance Plot Area (from Gross Plot Area)			
Common Plot			21.41
Total			21.41
BALANCE AREA OF PLOT (Net Plot Area - Recreational/Amenity space)	(A-Deductions)		90.07
PLOT AREA FOR COVERAGE (Net Plot Area)	(A-Deductions)		111.48
Plot Area for FAR (Net Plot Area + Road/Widening Area)	(A-Deductions)		111.48
COVERAGE CHECK			
Permissible Coverage area (70.00 %)			78.04
Proposed Coverage Area (64.13 %)			71.50
Total Prop. Coverage Area (64.13 %)			71.50
Balance coverage area (5.87 %)			6.54
FAR CHECK			
Perm. FAR Area (2.500)			278.70
Total Perm. FAR area			278.70
Residential FAR			143.00
Proposed FAR Area			154.79
Total Proposed FAR Area			154.79
Consumed FAR (Factor)			1.39
Balance FAR Area			123.91
BUILT UP AREA CHECK			
Total Proposed BuiltUp Area			214.50
ARCHITECT (Regd)			NIKHIL SHUKLA
ENGINEER (Regd)			
SUPERVISOR (Regd)			
OWNER (Regd)			MD SADIQUE HUSSIAN
DEVELOPMENT AUTHORITY			LOCAL BODY

COLOR INDEX	
PLOT BOUNDARY	Black
ABUTTING ROAD	Red
PROPOSED CONSTRUCTION	Green
COMMON PLOT	Yellow
ROAD WIDENING AREA	Blue
EXISTING (To be retained)	Orange
EXISTING (To be demolished)	Light Blue

Buildingwise Floor FAR Details				
Floor Name	Building Name		Total	
	Proposed Built Up Area (Sq.mt.)	Proposed FAR Area (Sq.mt.)	Total Proposed Built Up Area (Sq.mt.)	Total FAR Area (Sq.mt.)
Parking Floor	71.50	11.80	71.50	11.80
First Floor	71.50	71.50	71.50	71.50
Second Floor	71.50	71.50	71.50	71.50
Terrace Floor	0.00	0.00	0.00	0.00
Total :	214.50	154.80	214.50	154.80

Building USE/SUBUSE Details									
Building Name	Building Use	Building SubUse	Building Structure	Floor Name	Floor Use	Floor SubUse	FAR Name	FAR Use	FAR SubUse
H NO 70 B (BUILDING)	Residential	Bungalow/ Dwelling / Non Apartment	Non-Highrise	PARKING FLOOR PLAN	Residential	Bungalow/ Dwelling / Non Apartment	-	-	-
				FIRST FLOOR PLAN	Residential	Bungalow/ Dwelling / Non Apartment	Residential FAR	Residential	Bungalow/ Dwelling / Non Apartment
				SECOND FLOOR PLAN	Residential	Bungalow/ Dwelling / Non Apartment	Residential FAR	Residential	Bungalow/ Dwelling / Non Apartment
				TERRACE FLOOR PLAN	Residential	Bungalow/ Dwelling / Non Apartment	-	-	-

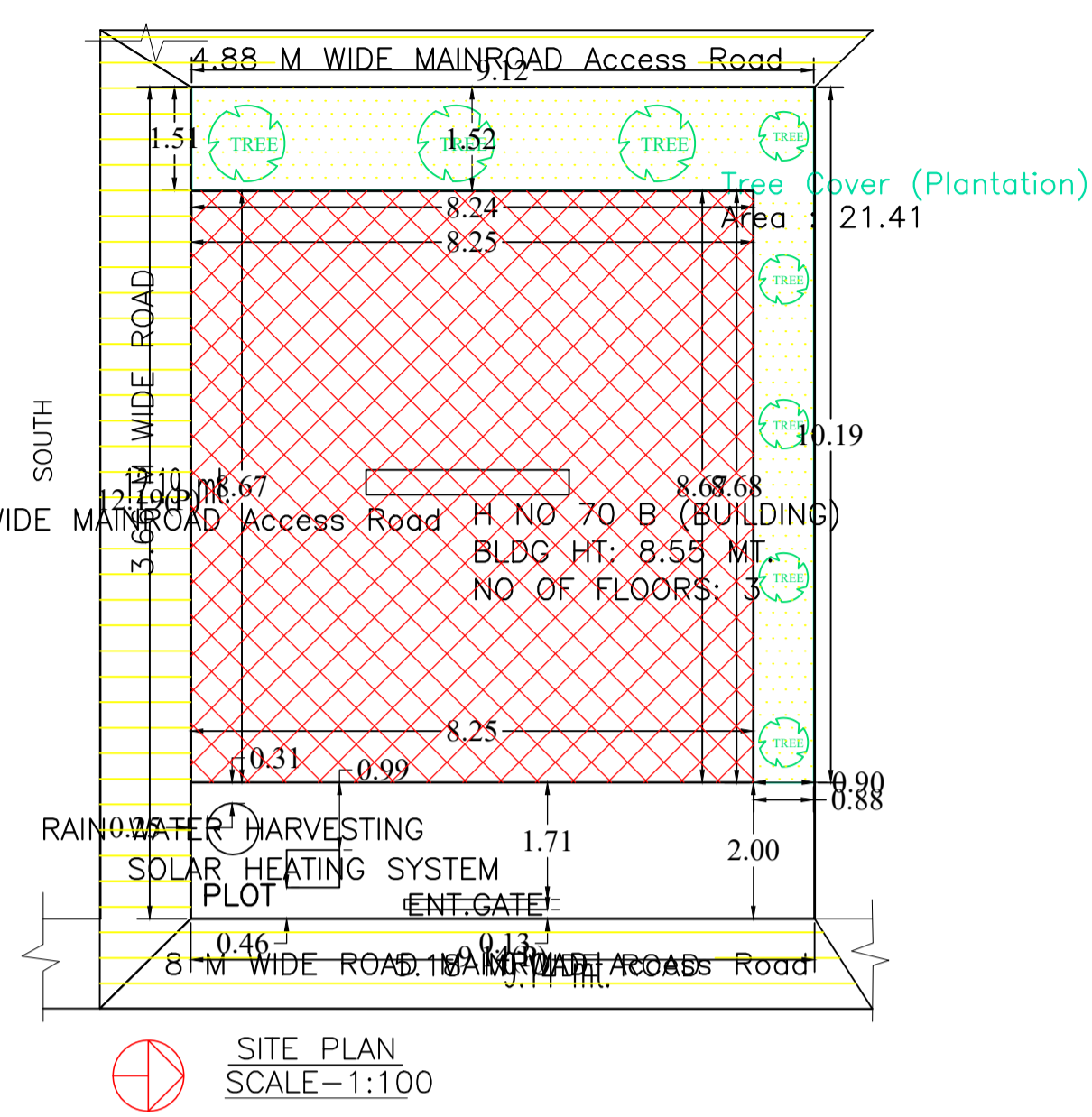

SITE PLAN SCALE: 1:100

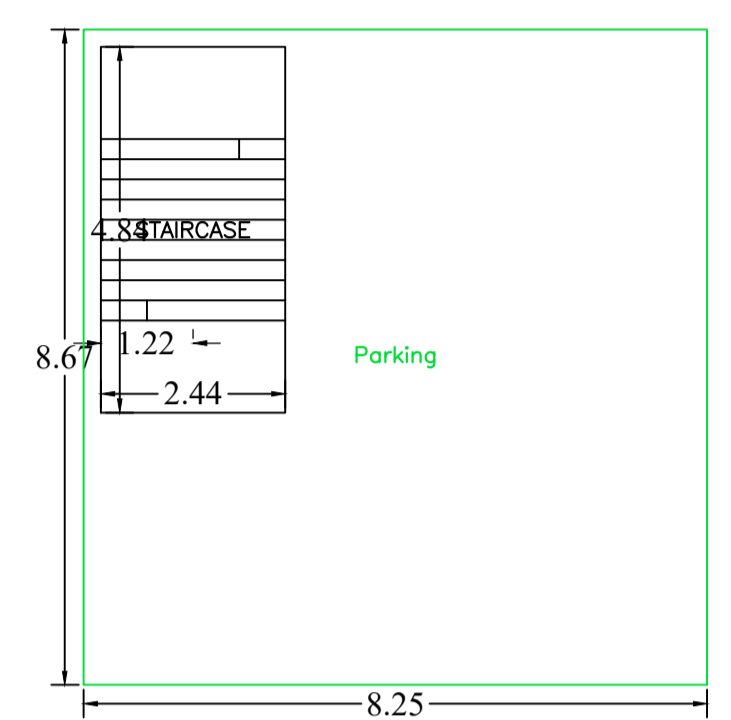

PARKING FLOOR PLAN (SCALE 1:100)

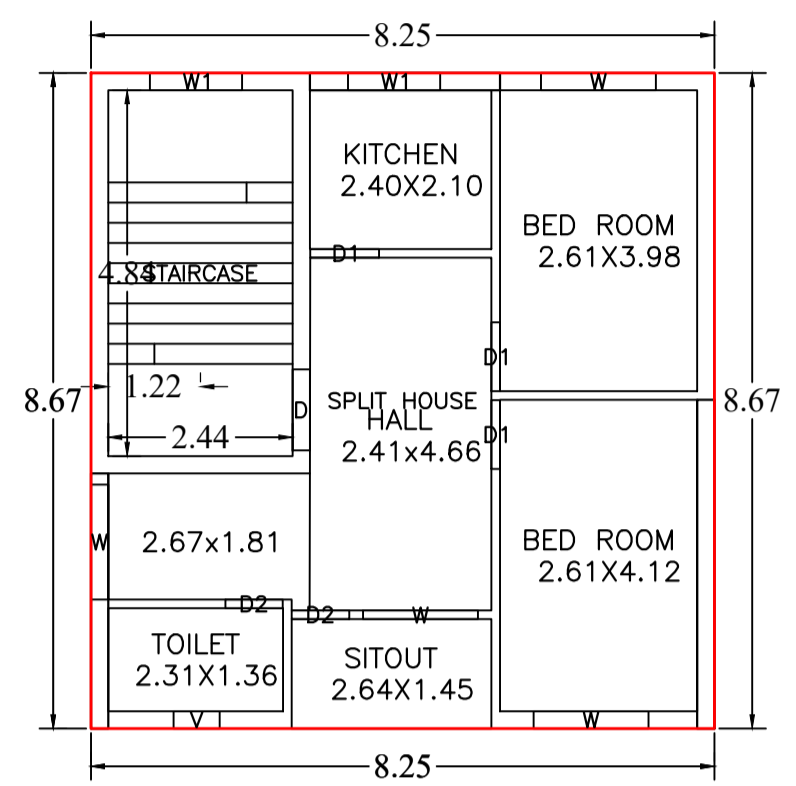

FIRST FLOOR PLAN (Proposed) (SCALE 1:100)

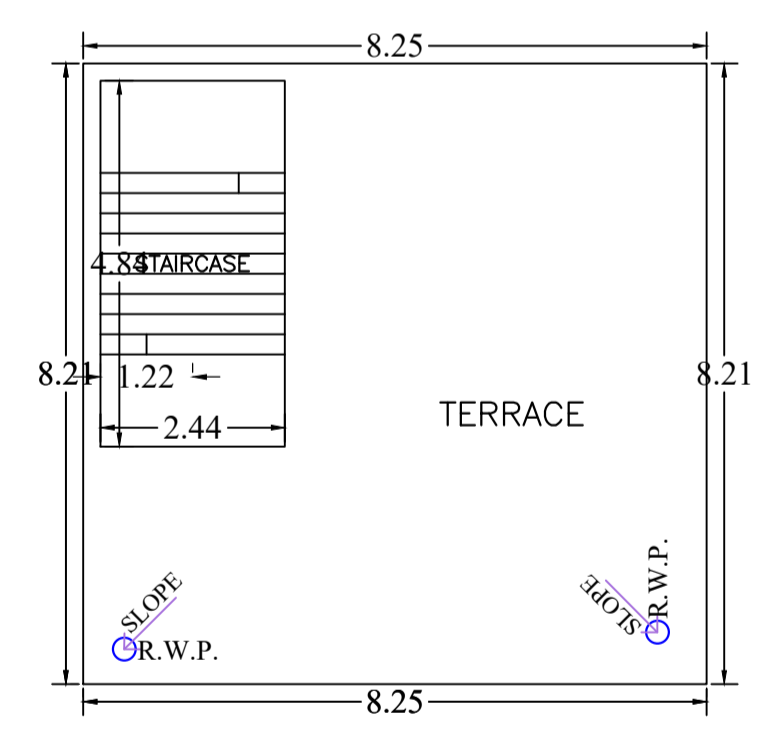

TERRACE FLOOR PLAN (SCALE 1:100)

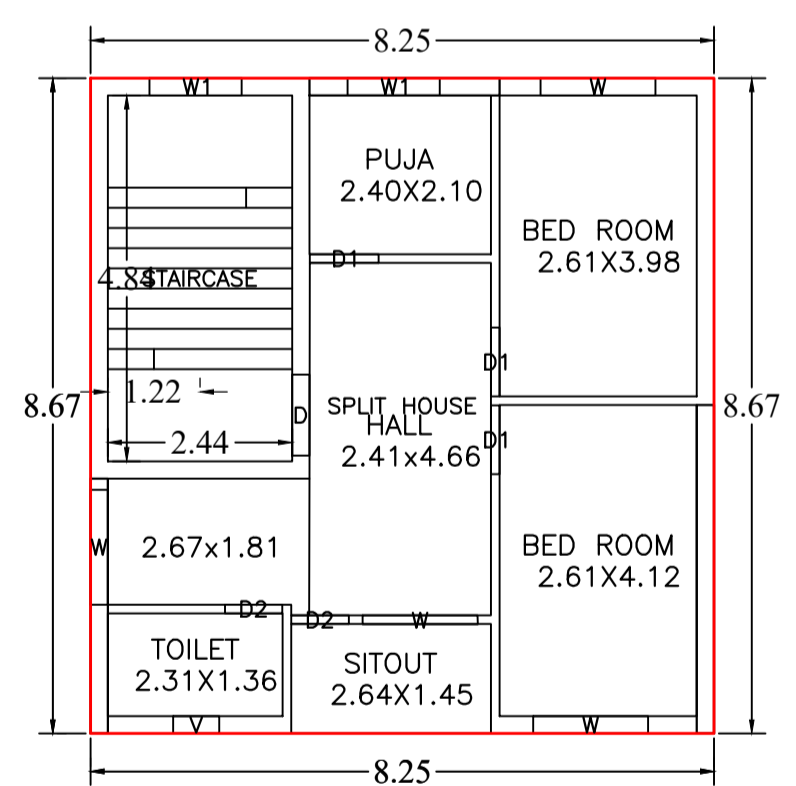

SECOND FLOOR PLAN (Proposed) (SCALE 1:100)

FAR & Tenement Details

Building	No. of Same Bldg	Total Built Up Area (Sq.mt.)	Deductions (Area in Sq.mt.)		Proposed FAR Area (Sq.mt.)	Add Area In FAR (Sq.mt.)	Total FAR Area (Sq.mt.)	Total Consumed Additional FAR Area (Sq.mt.)	Tnmt (No.)
			Parking	Resi.					
H NO 70 B (BUILDING)	1	214.50	59.70	143.00	143.00	11.80	154.80	154.80	01
Grand Total :	1	214.50	59.70	143.00	143.00	11.80	154.80	154.80	01

Building : H NO 70 B (BUILDING)

Floor Name	Total Built Up Area (Sq.mt.)	Deductions (Area in Sq.mt.)		Proposed FAR Area (Sq.mt.)	Add Area In FAR (Sq.mt.)	Total FAR Area (Sq.mt.)	Total Consumed Additional FAR Area (Sq.mt.)	Tnmt (No.)
		Parking	Resi.					
Parking Floor	71.50	59.70	0.00	11.80	0.00	11.80	11.80	00
First Floor	71.50	0.00	71.50	71.50	0.00	71.50	71.50	01
Second Floor	71.50	0.00	71.50	71.50	0.00	71.50	71.50	00
Terrace Floor	0.00	0.00	0.00	0.00	0.00	0.00	0.00	00
Total :	214.50	59.70	143.00	143.00	11.80	154.80	154.80	01
Total Number of Same Buildings	1							
Total :	214.50	59.70	143.00	143.00	11.80	154.80	154.80	01

SCHEDULE OF DOOR:

BUILDING NAME	NAME	LENGTH	HEIGHT	NOS
H NO 70 B (BUILDING)	D2	0.76	2.13	04
H NO 70 B (BUILDING)	D1	0.91	2.13	06
H NO 70 B (BUILDING)	D	1.07	2.13	02

SCHEDULE OF WINDOW/VENTILATION:

BUILDING NAME	NAME	LENGTH	HEIGHT	NOS
H NO 70 B (BUILDING)	V	0.61	0.61	02
H NO 70 B (BUILDING)	W1	1.22	1.22	04
H NO 70 B (BUILDING)	W	1.52	1.22	08

UnitBUA Table for Building : H NO 70 B (BUILDING)

FLOOR	Name	UnitBUA Type	UnitBUA Area	Carpet Area	No. of Rooms	No. of Tenement
FIRST FLOOR PLAN	SPLIT HOUSE	FLAT	143.00	138.32	6	1
SECOND FLOOR PLAN	SPLIT HOUSE	FLAT	0.00	0.00	6	0
Total:	-	-	143.00	138.32	12	1

LTP NAME AND SIGNATURE	STRUCTURAL ENG'S NAME AND SIGNATURE	BUILDER NAME AND SIGNATURE	DIGITAL SIGNATURE
NIKHIL SHUKLA JNAC/ARC/0015/2019			

Proposal Basic Information	
Proposal File No.	JNAC/BP/0106/W3/2024
Owner Name	MD SADIQUE HUSSIAN
Khata No	70 B BLOCK
Plot No	70 B BLOCK
Village Name	BELDIH
Use	Residential
SubUse	Bungalow/ Dwelling / Non Apartment

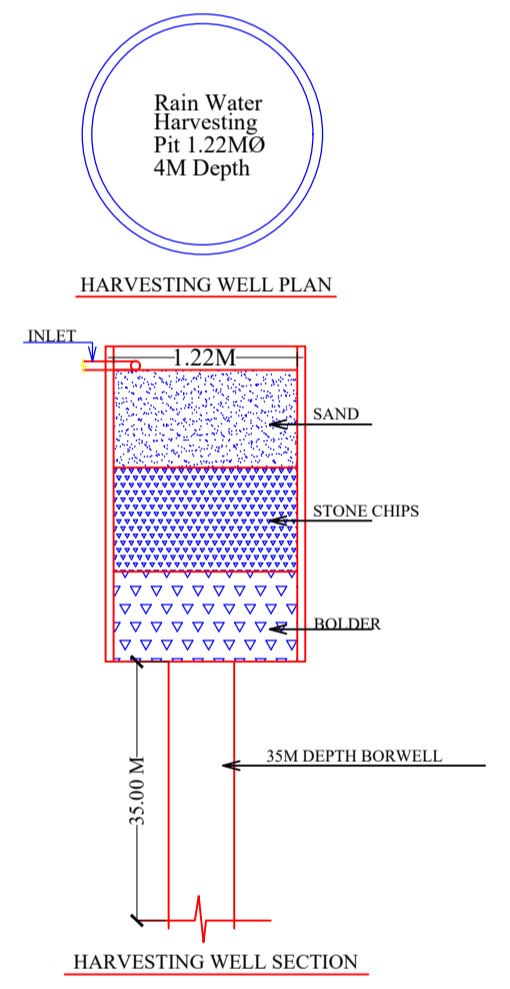
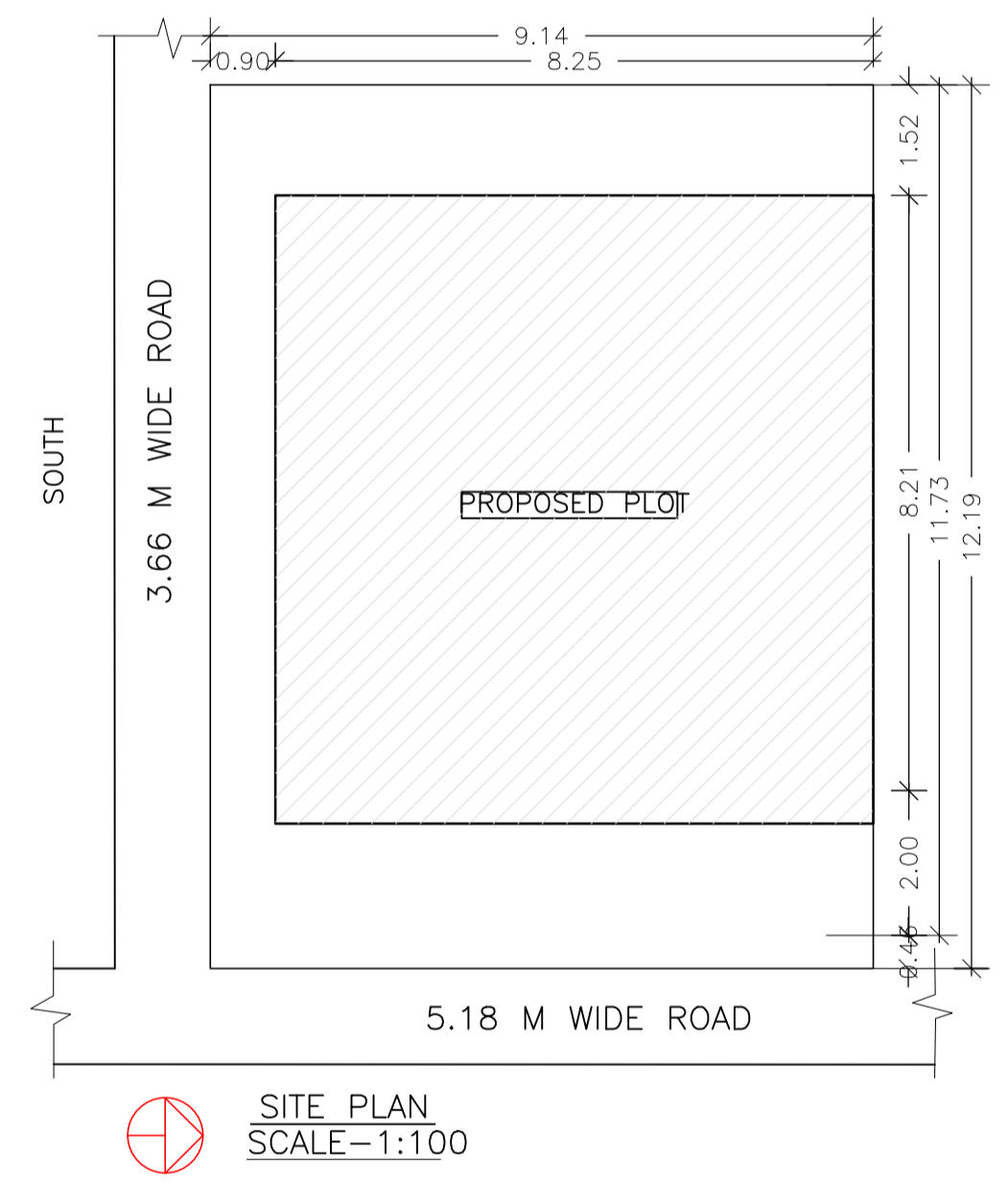
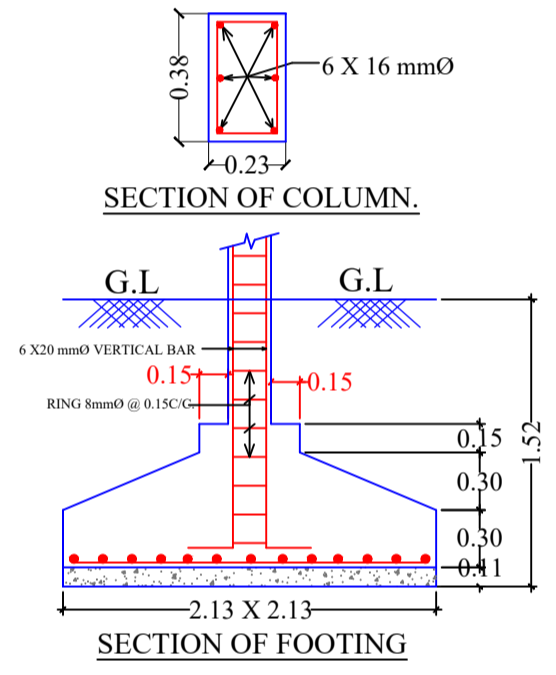
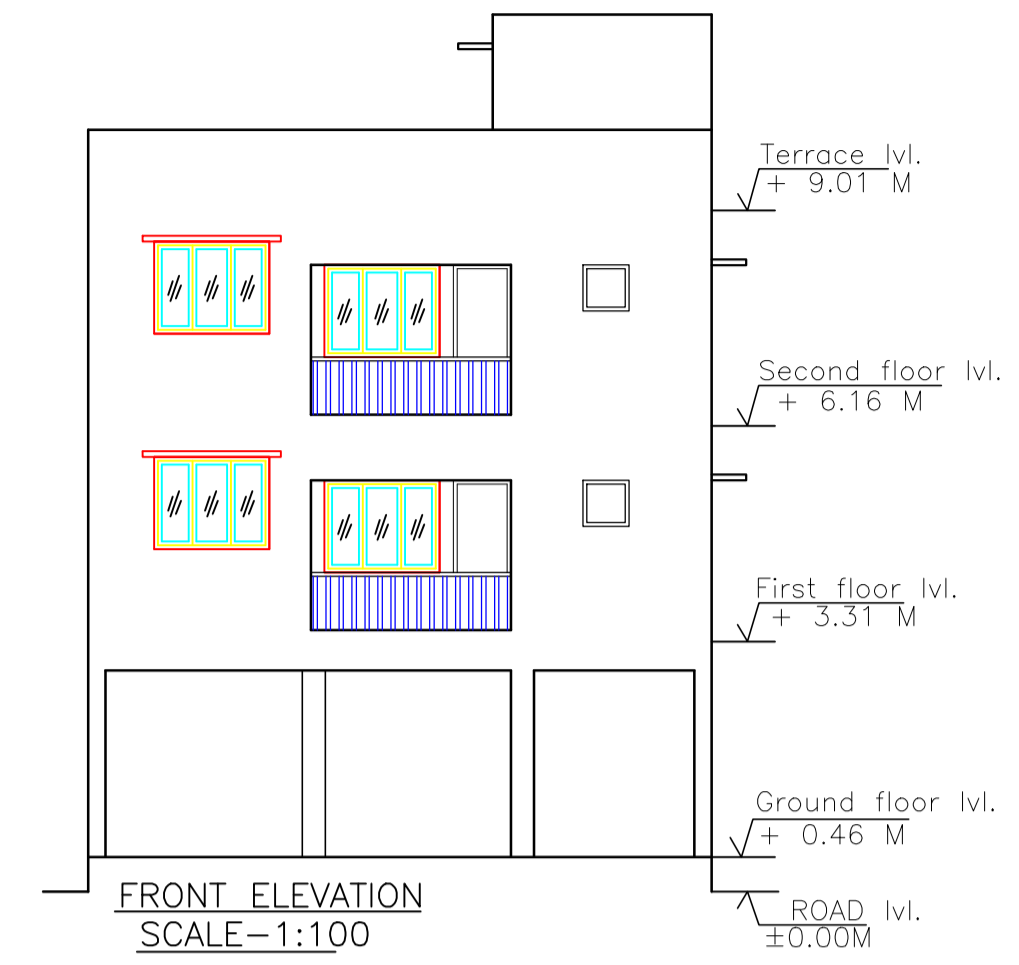
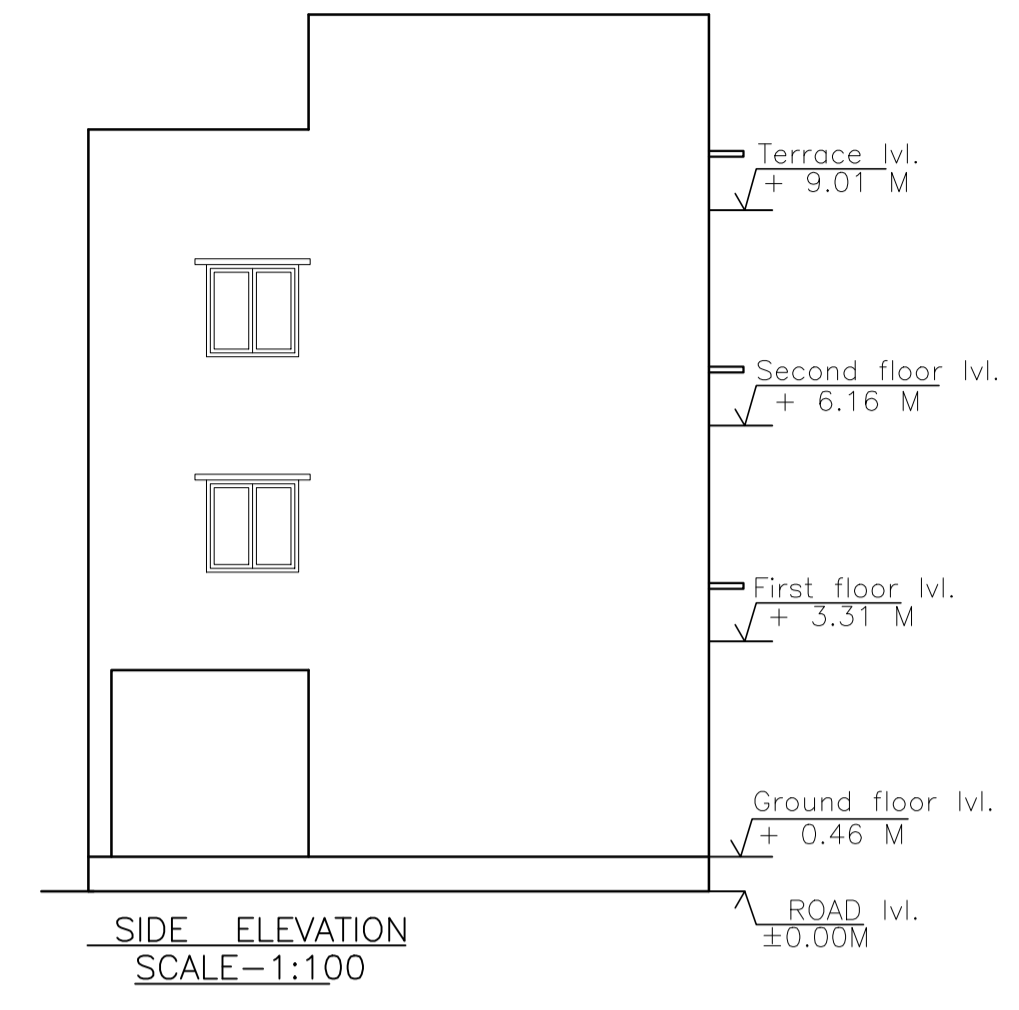
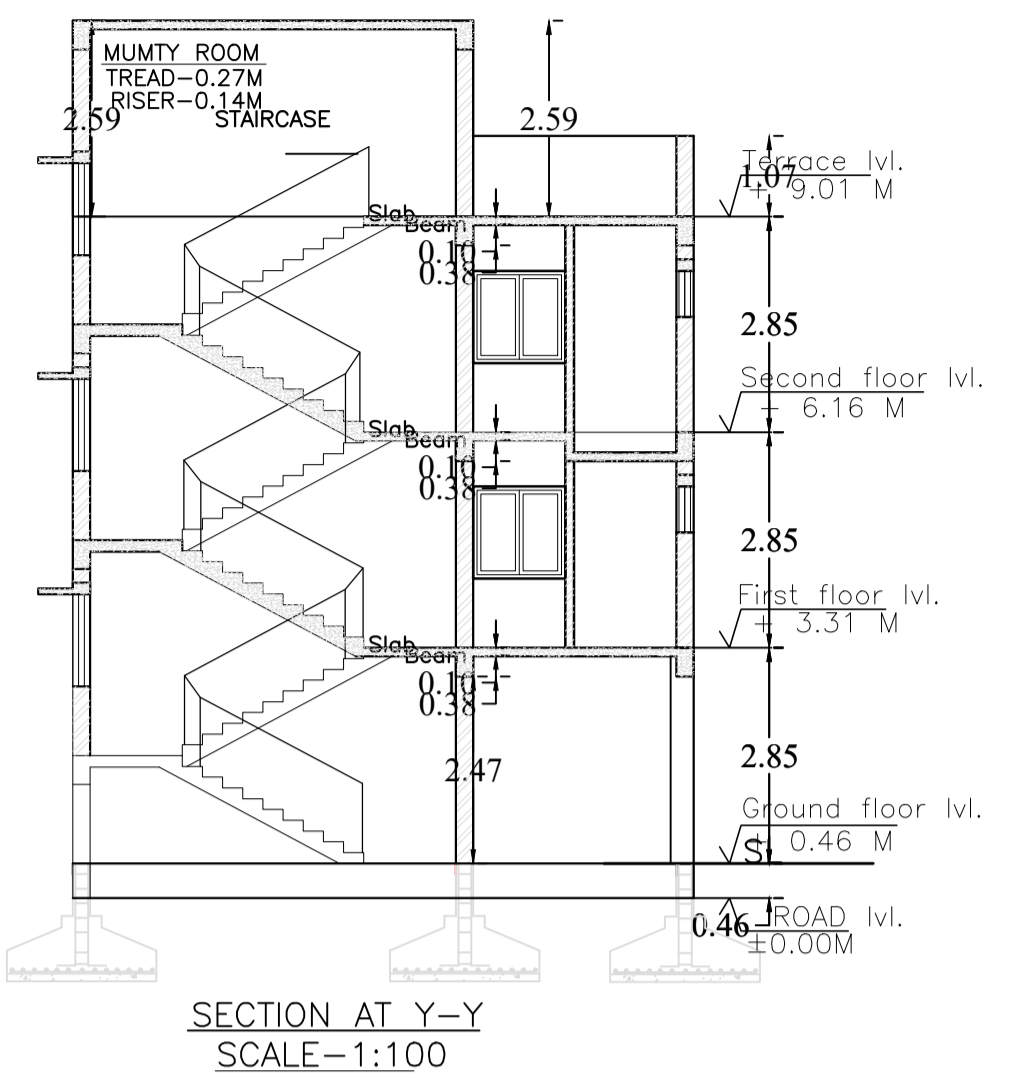
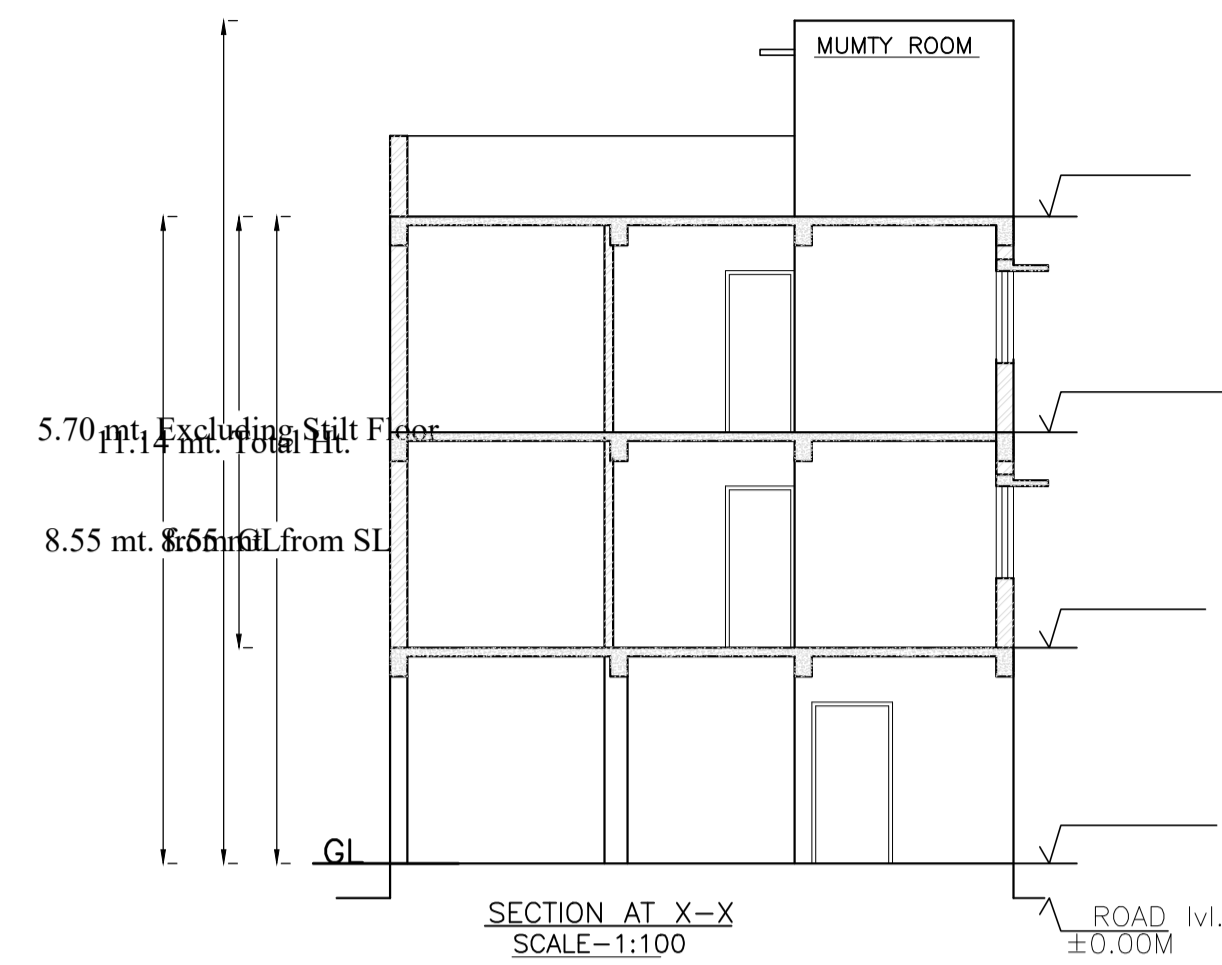

LTP NAME AND SIGNATURE	STRUCTURAL ENG'S NAME AND SIGNATURE	BUILDER NAME AND SIGNATURE	DIGITAL SIGNATURE
NIKHIL SHUKLA JNAC/ARC/0015/2019			