

Project Title :SRI UDAY SHANKAR DUTTA AND SRI GANESH DUTTA

AREA STATEMENT : JAMSHEDPUR NAC		VERSION NO. : 1.0.32	
PROJECT DETAIL :	Plot Use : Residential	VERSION DATE : 16/10/2020	
Tenant No. :	Plot Sub/Use : Bungalow/ Dwelling / Non Apartment		
Region : JHARKHAND URBAN LOCAL BODIES	Land Use Zone : NA		
District : EAST SINGHBHUM	Abutting Road Width : -		
Application Type : General Proposal	Plot No. : -		
Project Type : Building Permission	Revenue Survey No/Survey No : -		
Nature of Development : New	Thana No. : -		
Location : Old Area	Holding No. : -		
Sub Location : NA	Khasa No. : -		
Village/Mauza Name : -	North : -		
Ward No. : -	South : -		
Road/Street : -	East : -		
	West : -		

AREA DETAILS :		SQ.MT.	
AREA OF PLOT (Minimum)	(A)		74.27
Net Plot Area (Gross Plot Area - Deduction from Gross Plot area)	(A-Deductions)		74.27
Deductions for Balance Plot Area (from Gross Plot Area)			
COP Area			12.99
Total			12.99
Balance Plot Area (Net Plot Area - Recreational/Amenity space)	(A-Deductions)		61.28
Plot Area for Coverage (Net Plot Area)	(A-Deductions)		74.27
Plot Area for FSI (Net Plot Area + Road/Widening Area)	(A-Deductions)		74.27
Accessory/Use Area			0.94

COVERAGE CHECK		SQ.MT.	
Proposed Coverage Area (59.04%)			43.85
Total Coverage Area (59.04%)			43.85

FAR CHECK		SQ.MT.	
Proposed Area of FAR			96.87
Total Area of FAR			96.87

BUILT UP AREA CHECK		SQ.MT.	
Total Proposed Built Up Area			131.55
ARCH/ENGG/SUPERVISOR (Regd)		OWNER	

DEVELOPMENT AUTHORITY		LOCAL BODY	
-----------------------	--	------------	--

COLOR INDEX		Legend	
PLOT BOUNDARY			
ABUTTING ROAD			
PROPOSED WORK (COVERAGE AREA)			
EXISTING (To be retained)			
EXISTING (To be demolished)			

PARKING CALCULATION:		Prop. No.		Prop. Area	
Parking Type		1		34.68	
Other Parking					
Total Area					34.68

MARGIN DETAIL:		Front Margin		Rear Margin		Side1 Margin		Side2 Margin	
Building / Wing Name	Road Name	2.00		1.50		1.05		0.00	

FAR & Tenement Details (Table 4c-1)		Total Built Up Area (Sq.mt.)		Deductions (Area in Sq.mt.)		Proposed FAR Area (Sq.mt.)		Add Area In FAR (Sq.mt.)		Total FAR Area (Sq.mt.)		Trmt (No.)	
Building	No. of Same Bldg	131.55		34.68		87.70		9.17		96.87		01	
Grand Total:		1	131.55	34.68	87.70	9.17	96.87	01					

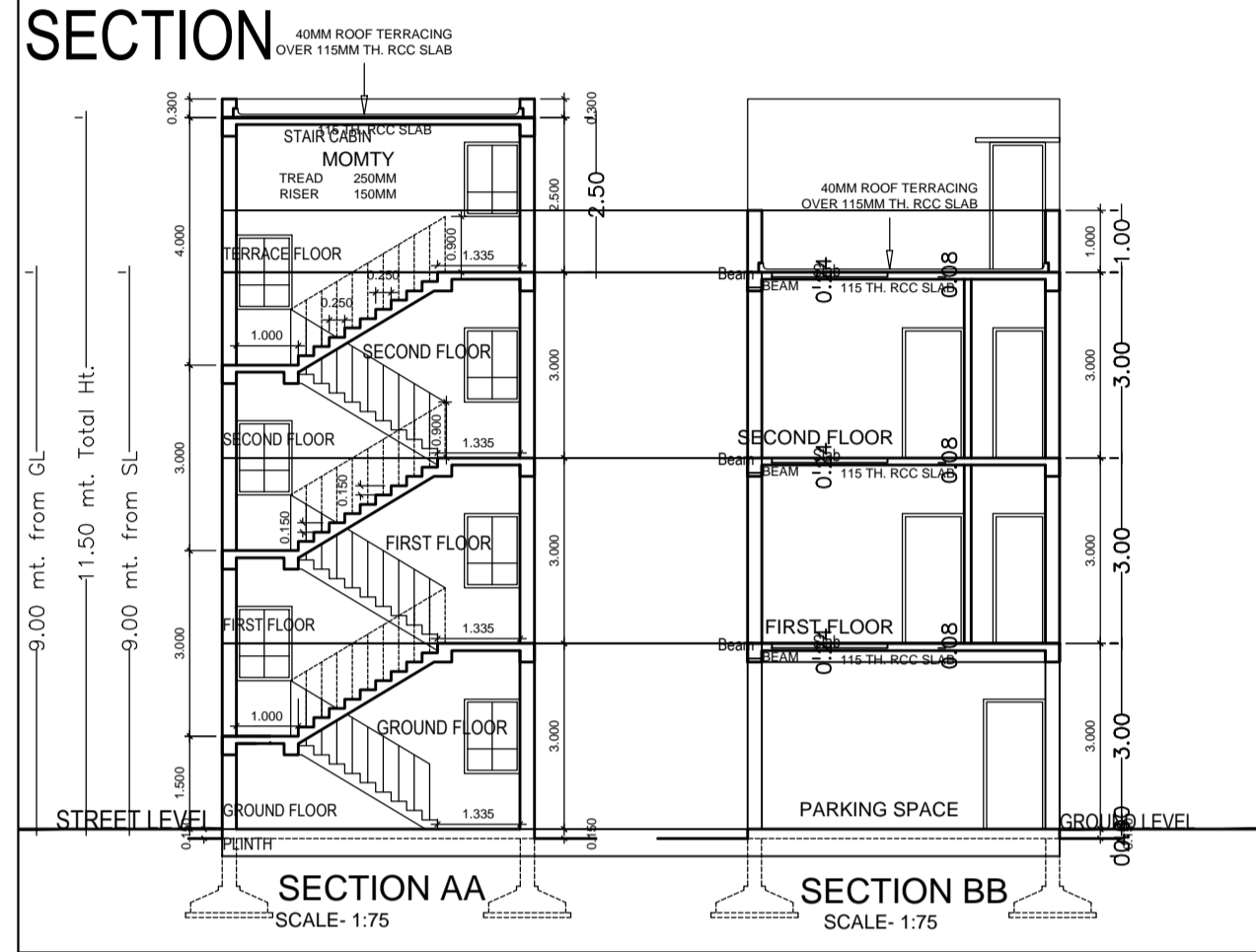
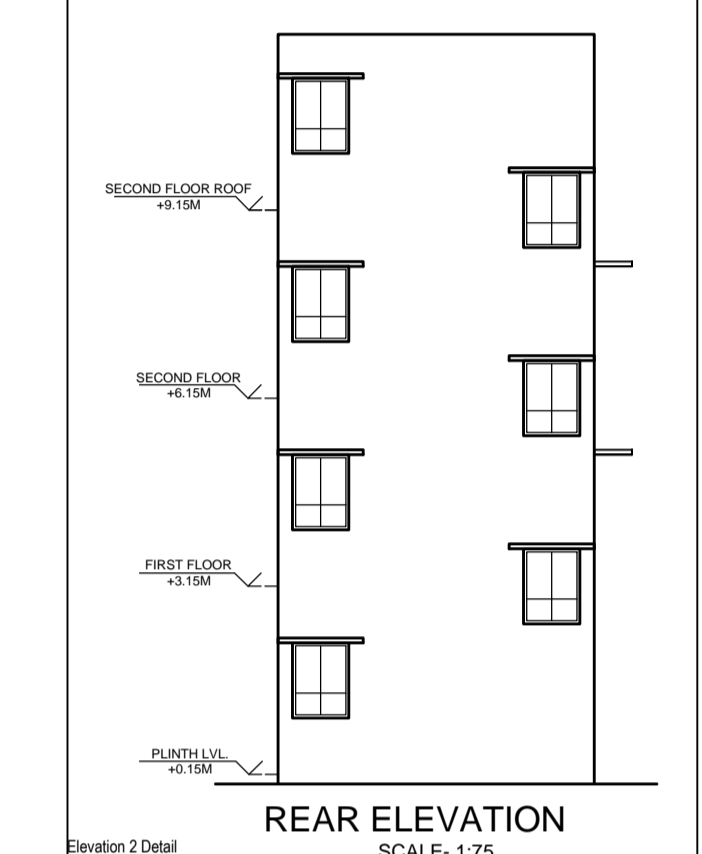
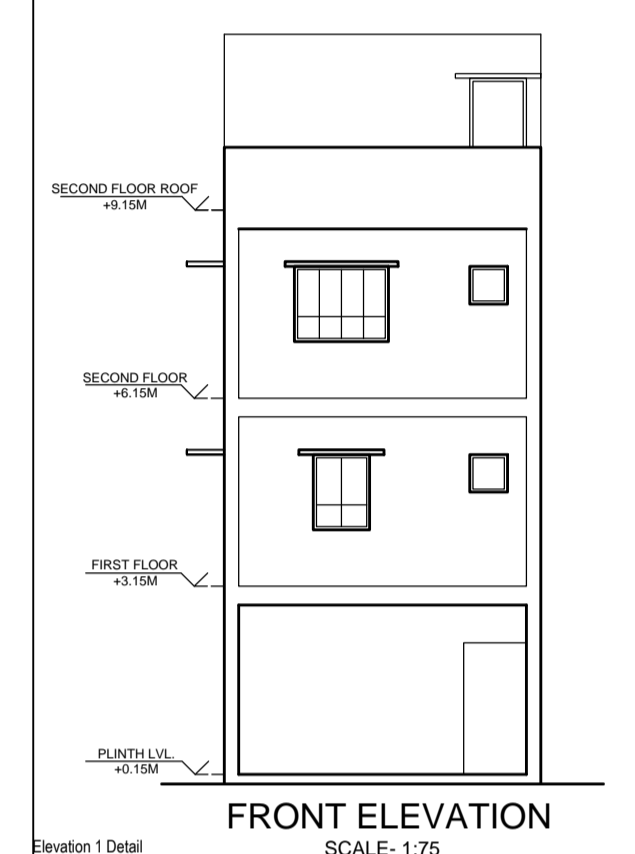
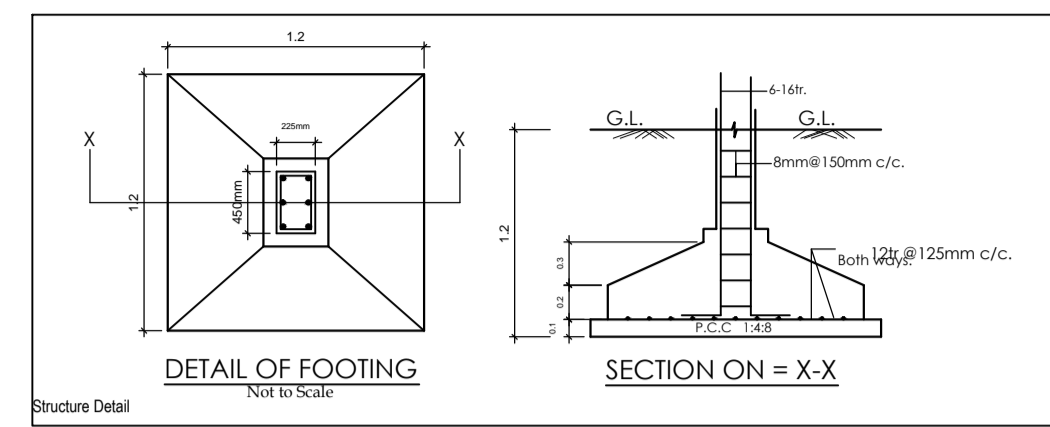
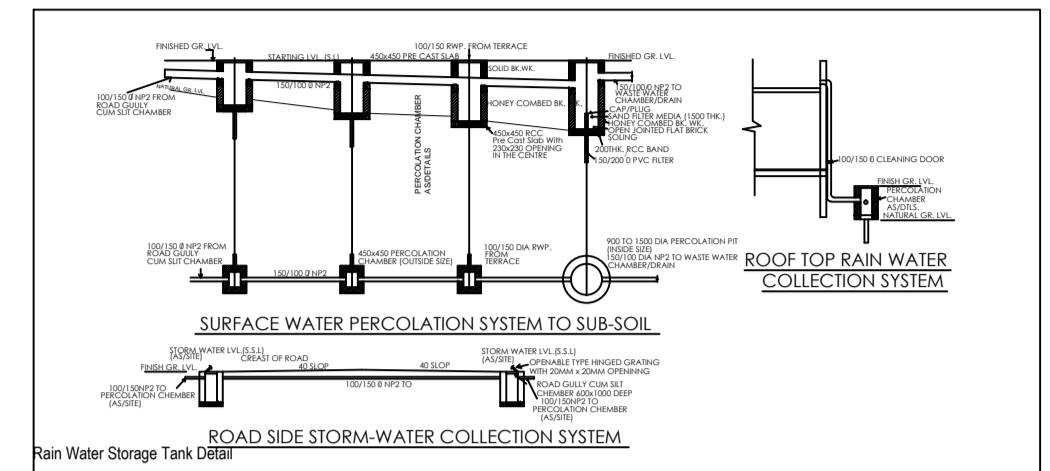
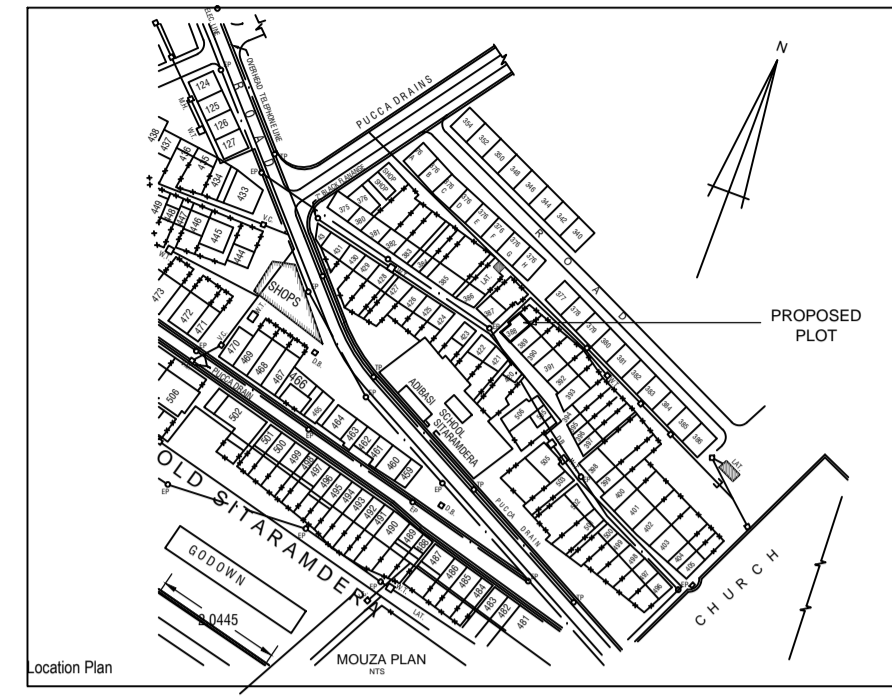

GENERAL SPECIFICATION

- FOUNDATION: RCC COLUMN FOOTING.
- SUPERSTRUCTURE: RCC FRAME STRUCTURE.
- ROOF AND INTERMEDIATE SLABS: 115MM TH. RCC SLAB.
- FLOORING: 25MM TH. IPS FLOORING OVER 115MM TH. SLAB.
- TOILET: W/C & E/WC WITH FIRST CLASS FITTINGS.
- DOORS: D1=1MX2.1M, D2=9MX2.1M, D3=75MX2.1M
- WINDOWS: W1=0.9MX1.2M, W2=1.0MX1.2M, W3=0.9MX0.9M
- FAR = 1.38
- GROUND COVERAGE = 60.5%

AREA STATEMENT

- TOTAL PLOT AREA = 72.50 SQM
- GROUND FLOOR AREA = 43.85 SQM
- FIRST FLOOR AREA = 43.85 SQM
- SECOND FLOOR AREA = 43.85 SQM
- TOTAL FAR FLOOR AREA = 100.11 SQM
- FAR = 1.38
- GROUND COVERAGE = 60.5%

PROPOSED RESIDENTIAL BUILDING OF SRI UDAY SHANKAR DUTTA & SRI GANESH DUTTA AT HOLDING NO. 388, SITARAMDERA OLD AREA, JAMSHEDPUR

SIGNATURE OF OWNER

SIGNATURE OF CONSULTANT

DATE:

SCALE: 1:75

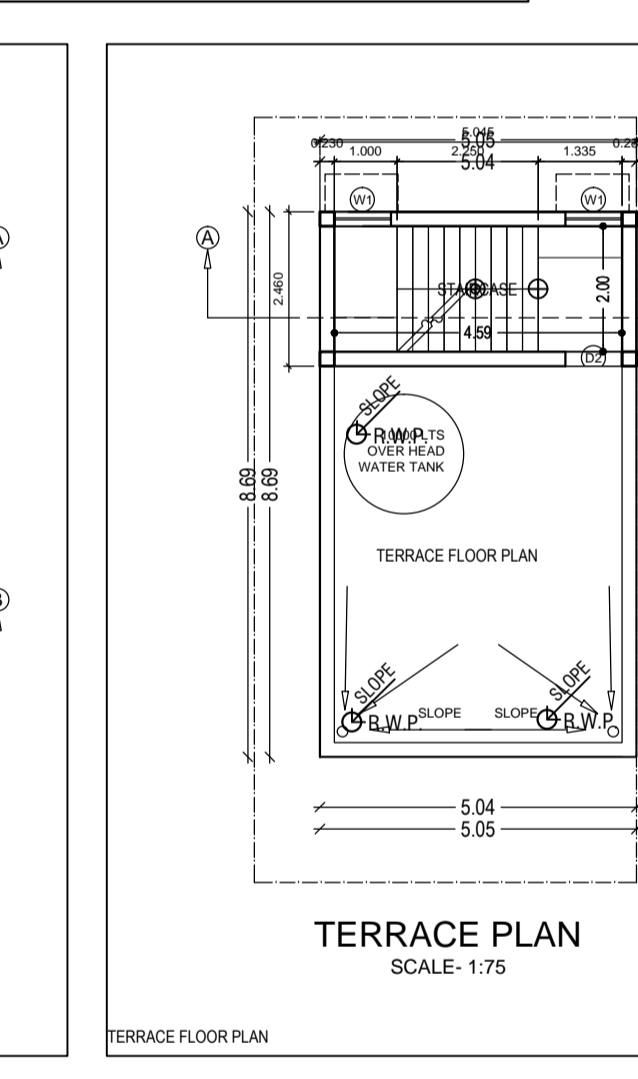
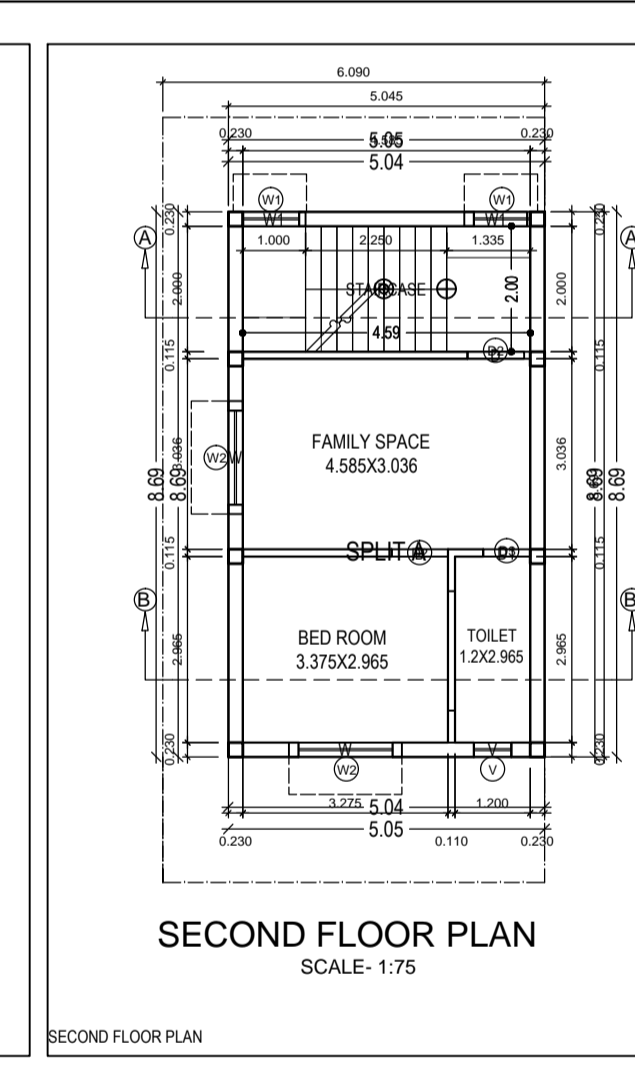
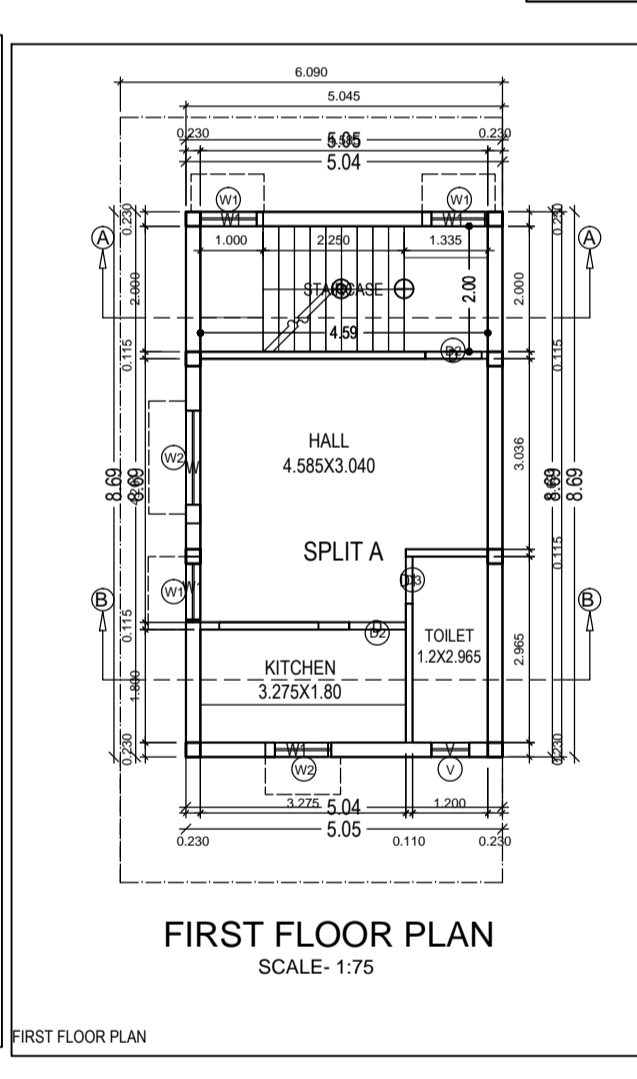
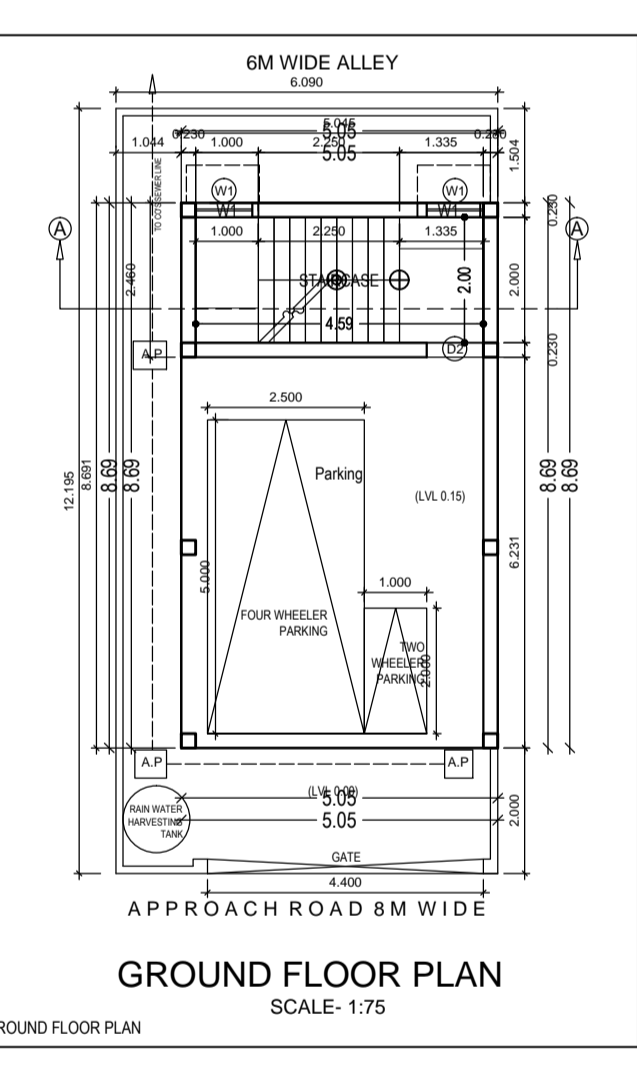
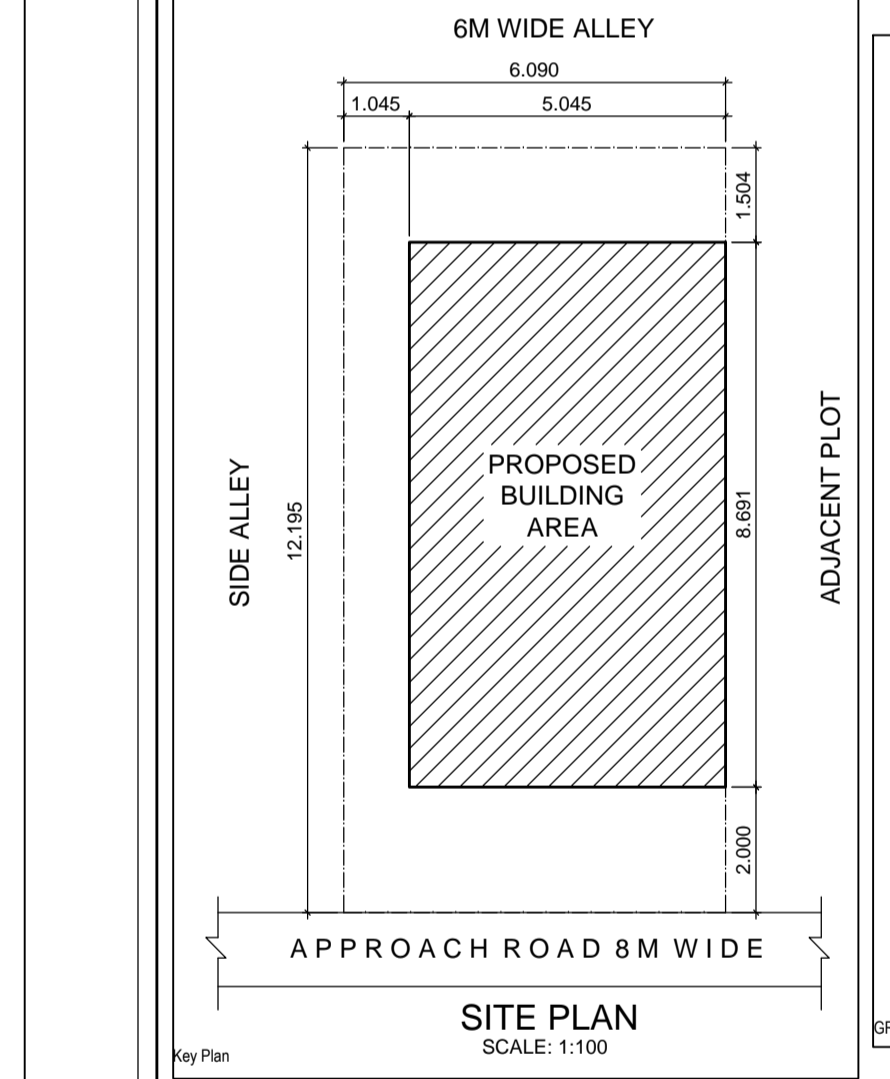
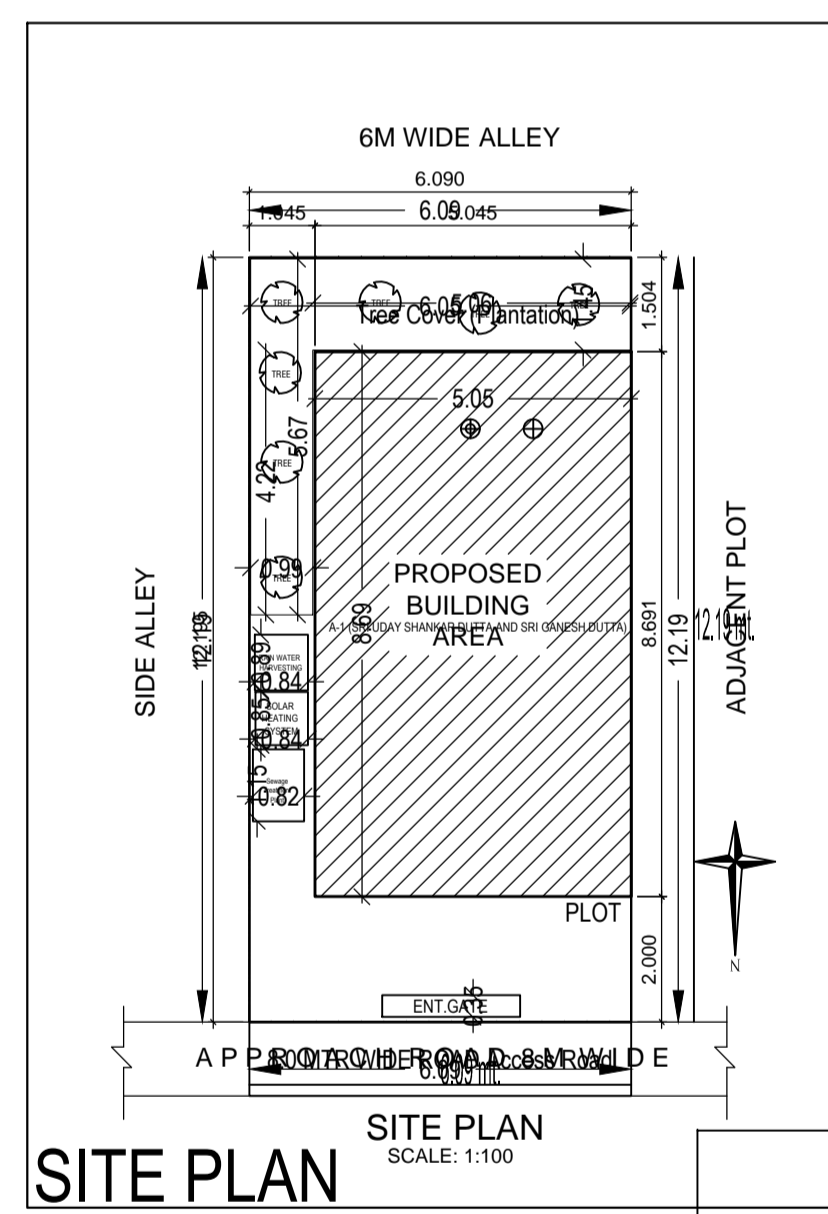

Building 'A' (SRI UDAY SHANKAR DUTTA AND SRI GANESH DUTTA)

Floor Name	Total Built Up Area (Sq.mt.)	Deductions (Area in Sq.mt.)	Proposed FAR Area (Sq.mt.)	Add Area In FAR (Sq.mt.)	Total FAR Area (Sq.mt.)	Trmt (No.)
Ground Floor	43.85	34.68	0.00	9.17	9.17	00
First Floor	43.85	0.00	43.85	0.00	43.85	01
Second Floor	43.85	0.00	43.85	0.00	43.85	00
Terrace Floor	0.00	0.00	0.00	0.00	0.00	00
Total	131.55	34.68	87.70	9.17	96.87	01
Total Number of Same Buildings	1					
Total	131.55	34.68	87.70	9.17	96.87	01

SCHEDULE OF JOINERY:

BUILDING NAME	NAME	LENGTH	HEIGHT	NOS
A (SRI UDAY SHANKAR DUTTA AND SRI GANESH DUTTA)	D1	0.75	2.13	02
A (SRI UDAY SHANKAR DUTTA AND SRI GANESH DUTTA)	D	0.90	2.13	04
Total	-	-	-	06

SCHEDULE OF JOINERY:

BUILDING NAME	NAME	LENGTH	HEIGHT	NOS
A (SRI UDAY SHANKAR DUTTA AND SRI GANESH DUTTA)	V	0.60	1.00	02
A (SRI UDAY SHANKAR DUTTA AND SRI GANESH DUTTA)	W1	1.00	2.70	08
A (SRI UDAY SHANKAR DUTTA AND SRI GANESH DUTTA)	W	1.80	2.70	03
Total	-	-	-	13

UnitBUA Table for Building 'A' (SRI UDAY SHANKAR DUTTA AND SRI GANESH DUTTA)

FLOOR	Name	UnitBUA Type	UnitBUA Area	Carpet Area	No. of Rooms	No. of Tenement
FIRST FLOOR PLAN	SPLIT A	FLAT	56.09	55.69	3	1
Total	-	-	56.09	55.69	6	1