

Proposal Basic Information	
Proposal File No.	JNAC/EP/0009/W11/2022
Owner Name	SRI UDAY SHANKAR DUTTA AND SRI GANESH DUTTA
Khata No	52
Plot No	50
Village Name	Sitaramdera
Use	Residential
SubUse	Bungalow/ Dwelling / Non Apartment

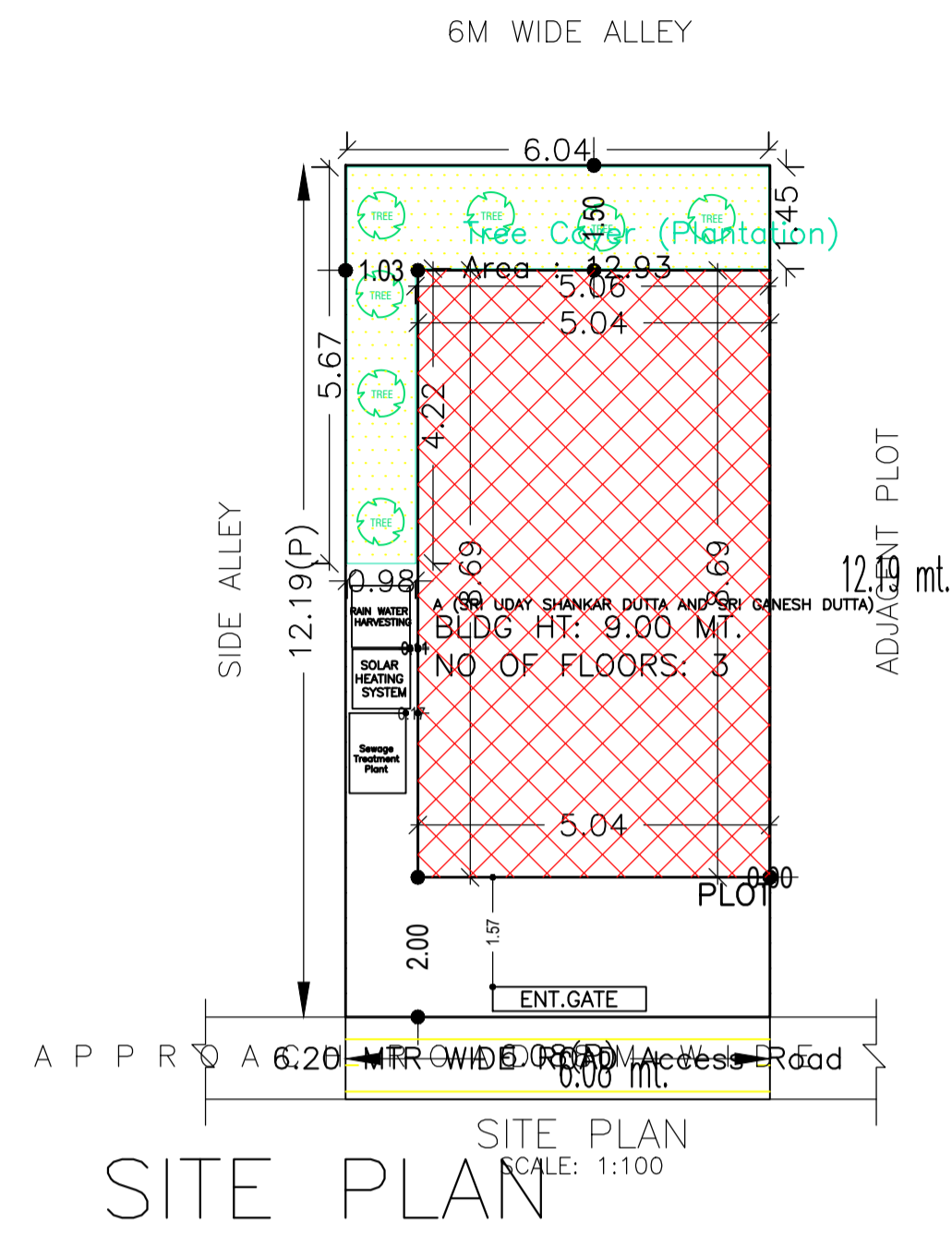

COLOR INDEX	
PLOT BOUNDARY	Black
ABUTTING ROAD	Green
PROPOSED CONSTRUCTION	Red
COMMON PLOT	Yellow
ROAD WIDENING AREA	Orange
EXISTING (To be retained)	Blue
EXISTING (To be demolished)	Light Blue

AREA STATEMENT		VERSION NO.: 1.0.62
JAMSHEDPUR NAC		VERSION DATE: 16/10/2020
PROJECT DETAIL:		
Region: JHARKHAND URBAN LOCAL BODIES	Plot Use: Residential	
District: EAST SINGHBHUM	Plot SubUse: Bungalow/ Dwelling / Non Apartment	
Authority: JAMSHEDPUR NAC	Plot/Nearby/Religious/Structure: NA	
Inward No: JNAC/EP/0009/W11/2022	Plot/SubPlot No: 50	
Application Type: General Proposal	North: Road Width - 8.0 MTR WIDE MAIN ROAD	
Project Type: Building Permission	South: -	
Nature of Development: New	East: -	
Location of Development Area: Old Area	West: -	
AREA DETAILS:		
AREA OF PLOT (Minimum)	(A)	SQ.MT.
NET AREA OF PLOT(Gross Plot Area - Deduction from Gross Plot area)		74.15
Deduction for Balance Plot Area(from Gross Plot Area)		
Common Plot		12.93
Total		12.93
BALANCE AREA OF PLOT(Net Plot Area - Recreational/Amenity space)	(A-Deductions)	61.22
PLOT AREA FOR COVERAGE(Net Plot Area)	(A-Deductions)	74.15
Plot Area for FAR (Net Plot Area + Road Widening Area)	(A-Deductions)	74.15
COVERAGE CHECK		
Permissible Coverage area (70.00 %)		51.90
Proposed Coverage Area (59.14 %)		43.85
Total Prop. Coverage Area (59.14 %)		43.85
Balance coverage area (10.86 %)		8.05
FAR CHECK		
Perm. FAR Area (2.50)		185.38
Total Perm. FAR area		185.38
Residential FAR		87.70
Proposed FAR Area		96.87
Total Proposed FAR Area		96.87
Consumed FAR (Factor)		1.31
Balance FAR Area		88.51
BUILT UP AREA CHECK		
Total Proposed BuiltUp Area		131.55
ARCHITECT (Regd)	Amarjeet Balmuchu	
ENGINEER (Regd)		
SUPERVISOR (Regd)		
OWNER (Regd)	SRI UDAY SHANKAR DUTTA AND SRI GANESH DUTTA	
DEVELOPMENT AUTHORITY	LOCAL BODY	

FAR & Tenement Details (Table 4c-1)

Building	No. of Same Bldg	Total Built Up Area (Sq.mt.)	Deductions (Area in Sq.mt.)	Proposed FAR Area (Sq.mt.)	Add Area In FAR (Sq.mt.)	Total FAR Area (Sq.mt.)	Total Consumed Additional FAR Area (Sq.mt.)	Tnmt (No.)
A (SRI UDAY SHANKAR DUTTA AND SRI GANESH DUTTA)	1	131.55	34.68	87.70	9.17	96.87	96.87	01
Grand Total :	1	131.55	34.68	87.70	9.17	96.87	96.87	01

Buildingwise Floor FAR Details

Floor Name	Building Name		Total	
	Proposed Built Up Area (Sq.mt.)	Proposed FAR Area (Sq.mt.)	Total Proposed Built Up Area (Sq.mt.)	Total FAR Area (Sq.mt.)
Ground Floor	43.85	9.17	43.85	9.17
First Floor	43.85	43.85	43.85	43.85
Second Floor	43.85	43.85	43.85	43.85
Terrace Floor	0.00	0.00	0.00	0.00
Total :	131.55	96.87	131.55	96.87

Building USE/SUBUSE Details

Building Name	Building Use	Building SubUse	Building Structure
A (SRI UDAY SHANKAR DUTTA AND SRI GANESH DUTTA)	Residential	Bungalow/ Dwelling / Non Apartment	Non-Highrise

LTP NAME AND SIGNATURE	STRUCTURAL ENG'S NAME AND SIGNATURE	BUILDER NAME AND SIGNATURE	DIGITAL SIGNATURE
Amarjeet Balmuchu JNAC/ARC/0008/2018			

Proposal Basic Information	
Proposal File No.	JNAC/EP/0009/W11/2022
Owner Name	SRI UDAY SHANKAR DUTTA AND SRI GANESH DUTTA
Khata No	52
Plot No	50
Village Name	Sitaramdera
Use	Residential
SubUse	Bungalow/ Dwelling / Non Apartment

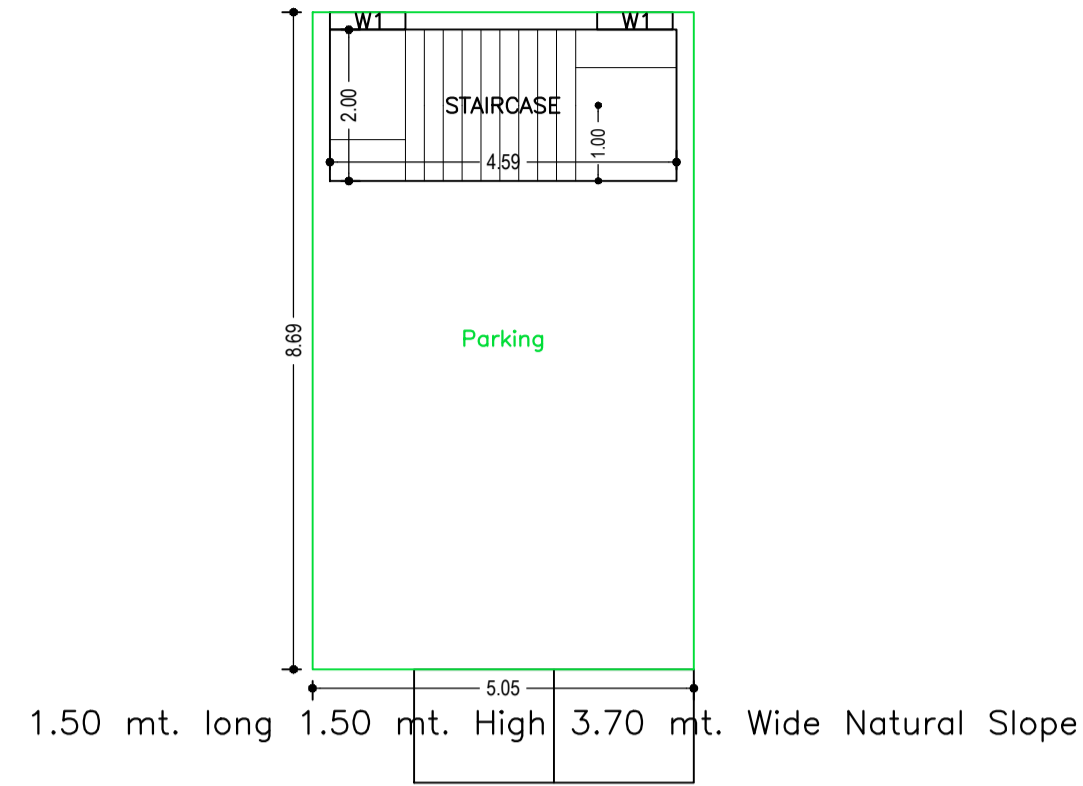

GROUND FLOOR PLAN
(SCALE 1:100)

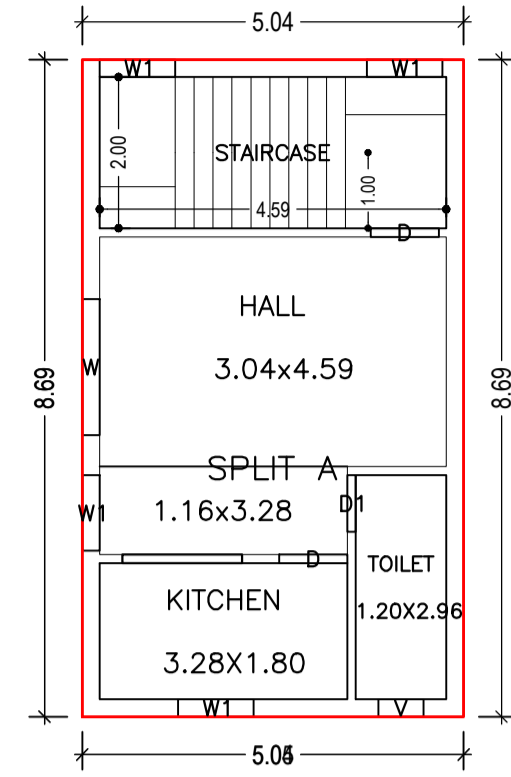

FIRST FLOOR PLAN
(Proposed)
(SCALE 1:100)

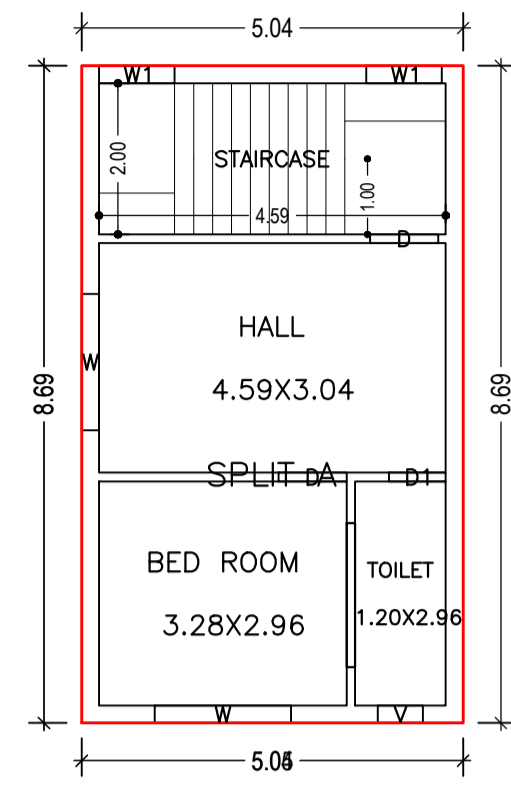

SECOND FLOOR PLAN
(Proposed)
(SCALE 1:100)

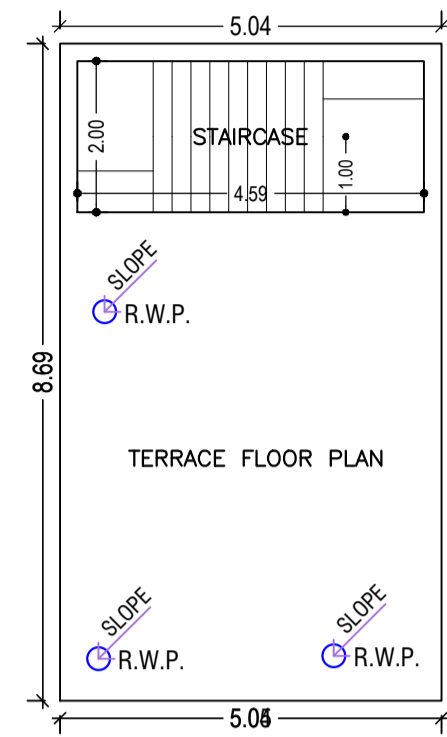

TERRACE FLOOR PLAN
(SCALE 1:100)

Building :A (SRI UDAY SHANKAR DUTTA AND SRI GANESH DUTTA)

Floor Name	Total Built Up Area (Sq.mt.)	Deductions (Area in Sq.mt.)		Proposed FAR Area (Sq.mt.)		Add Area In FAR (Sq.mt.)	Total FAR Area (Sq.mt.)	Total Consumed Additional FAR Area (Sq.mt.)	Tnmt (No.)
		Parking	Resi.	Parking	Resi.				
Ground Floor	43.85	34.68	0.00	0.00	9.17	9.17	9.17	0.00	00
First Floor	43.85	0.00	43.85	0.00	43.85	43.85	43.85	0.00	01
Second Floor	43.85	0.00	43.85	0.00	43.85	43.85	43.85	0.00	00
Terrace Floor	0.00	0.00	0.00	0.00	0.00	0.00	0.00	0.00	00
Total :	131.55	34.68	87.70	9.17	96.87	96.87	96.87	0.00	01
Total Number of Same Buildings :	1								
Total :	131.55	34.68	87.70	9.17	96.87	96.87	96.87	0.00	01

SCHEDULE OF DOOR:

BUILDING NAME	NAME	LENGTH	HEIGHT	NOS
A (SRI UDAY SHANKAR DUTTA AND SRI GANESH DUTTA)	D1	0.75	2.13	02
A (SRI UDAY SHANKAR DUTTA AND SRI GANESH DUTTA)	D	0.90	2.13	04

SCHEDULE OF WINDOW/VENTILATION:

BUILDING NAME	NAME	LENGTH	HEIGHT	NOS
A (SRI UDAY SHANKAR DUTTA AND SRI GANESH DUTTA)	V	0.60	2.70	02
A (SRI UDAY SHANKAR DUTTA AND SRI GANESH DUTTA)	W1	1.00	2.70	08
A (SRI UDAY SHANKAR DUTTA AND SRI GANESH DUTTA)	W	1.80	2.70	03

UnitBUA Table for Building :A (SRI UDAY SHANKAR DUTTA AND SRI GANESH DUTTA)

FLOOR	Name	UnitBUA Type	UnitBUA Area	Carpet Area	No. of Rooms	No. of Tenement
FIRST FLOOR PLAN	SPLIT A	FLAT	56.09	55.69	3	1
SECOND FLOOR PLAN	SPLIT A	FLAT	0.00	0.00	3	0
Total:	-	-	56.09	55.69	6	1

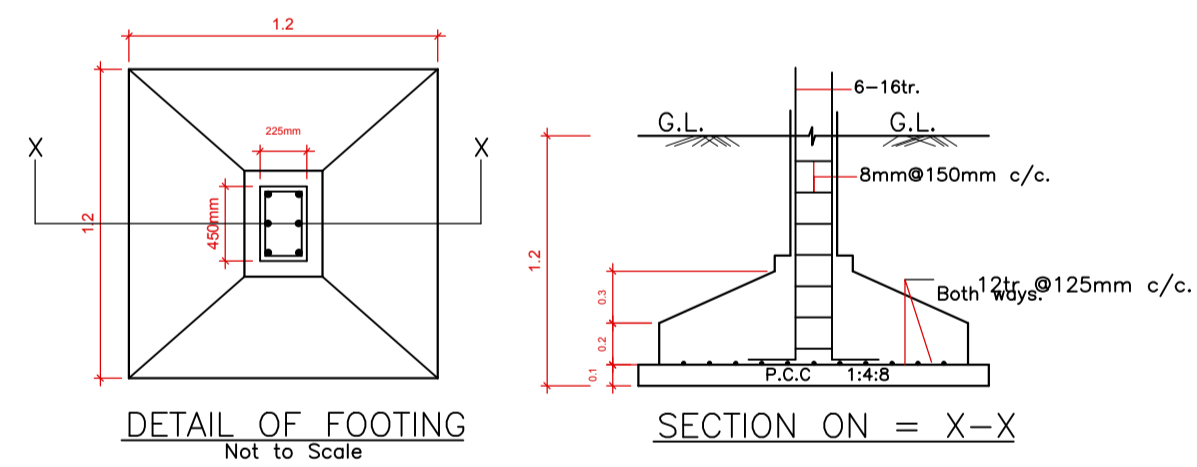
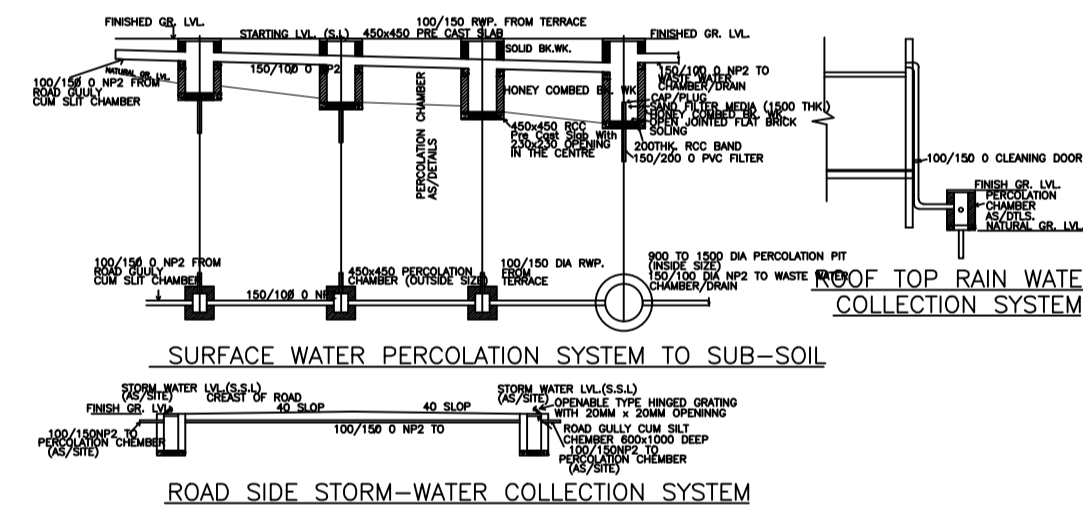

LTP NAME AND SIGNATURE	STRUCTURAL ENG'S NAME AND SIGNATURE	BUILDER NAME AND SIGNATURE	DIGITAL SIGNATURE
Amarjeet Balmuchu JNAC/ARC/0008/2018			

Proposal Basic Information

Proposal File No.	JNAC/EP/0009/W11/2022
Owner Name	SRI UDAY SHANKAR DUTTA AND SRI GANESH DUTTA
Khata No	52
Plot No	50
Village Name	Sitaramdera
Use	Residential
SubUse	Bungalow/ Dwelling / Non Apartment

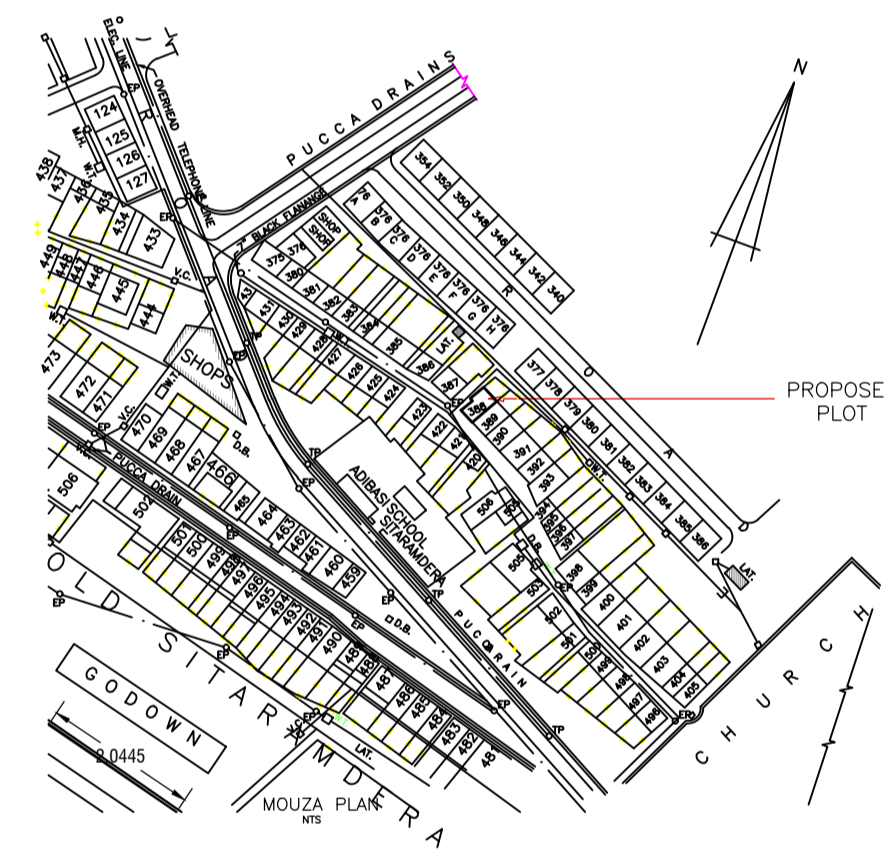
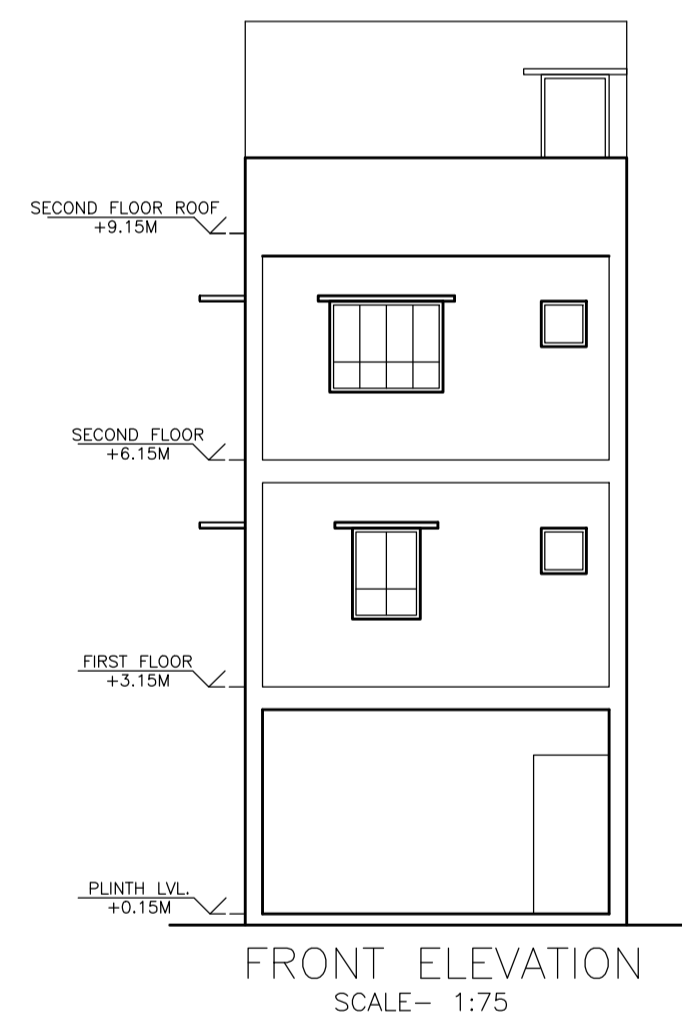
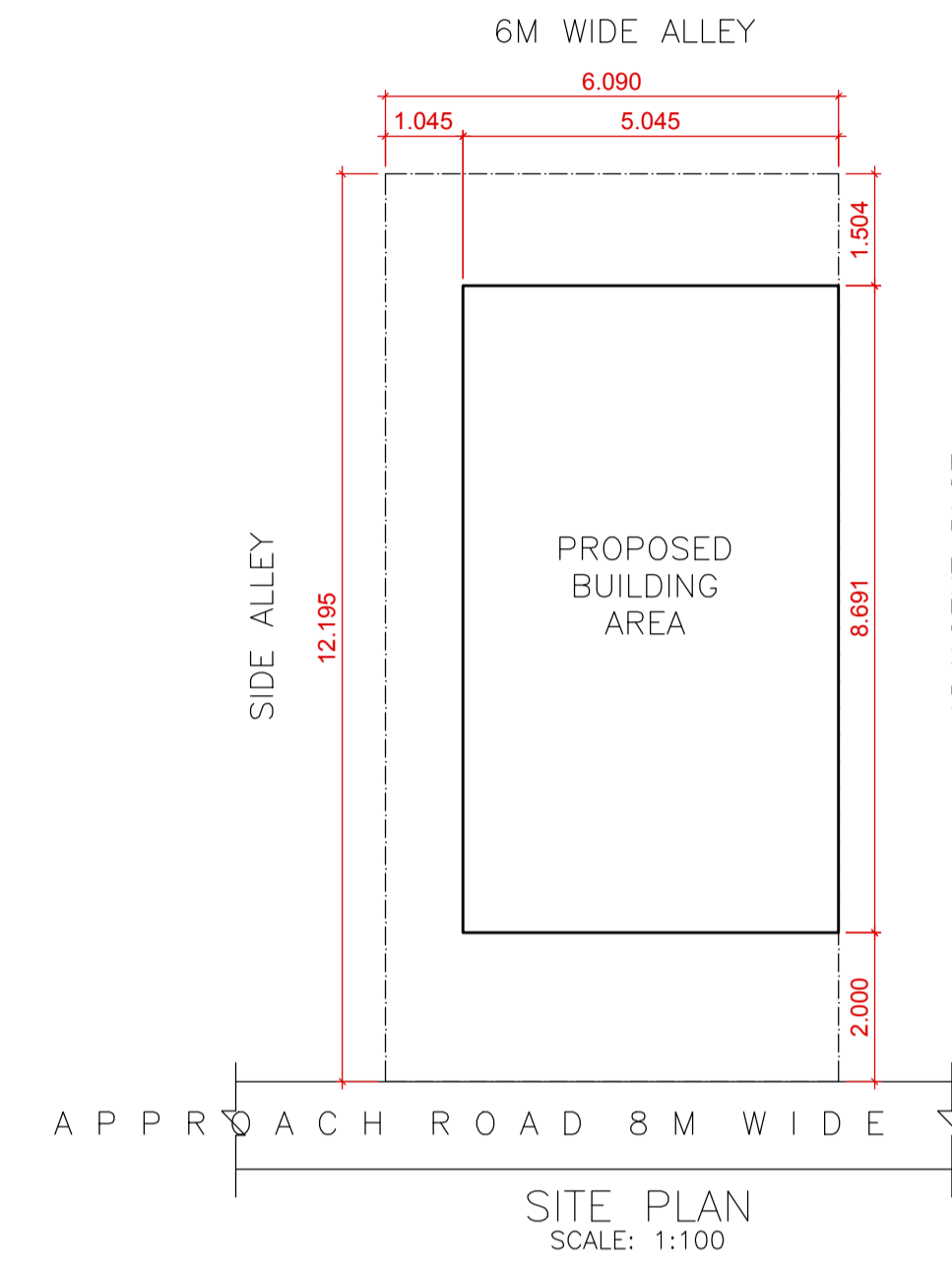
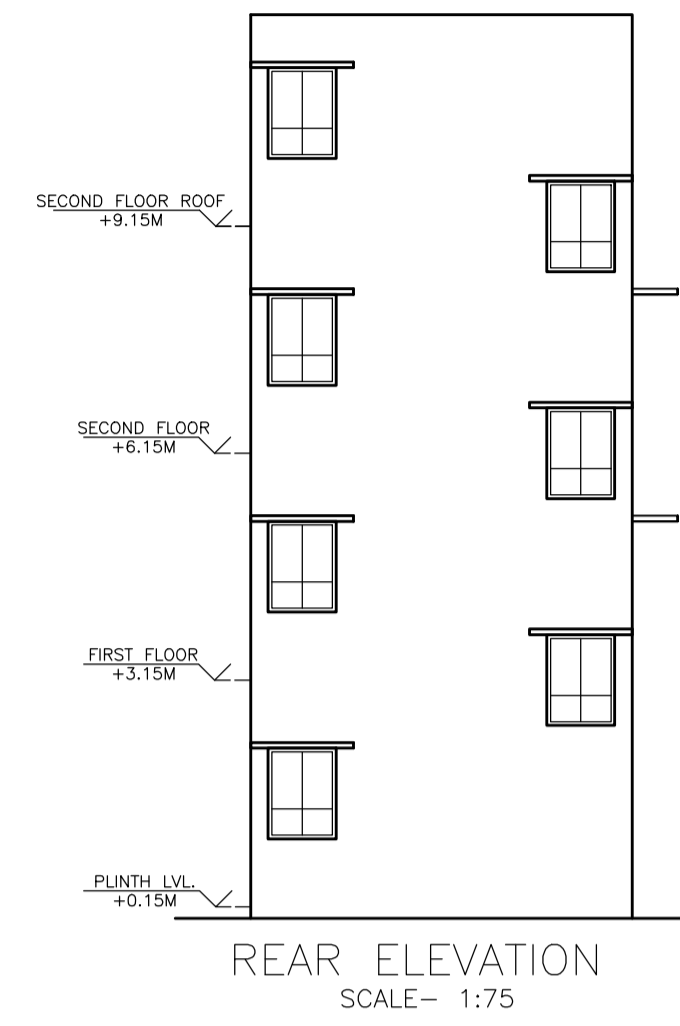
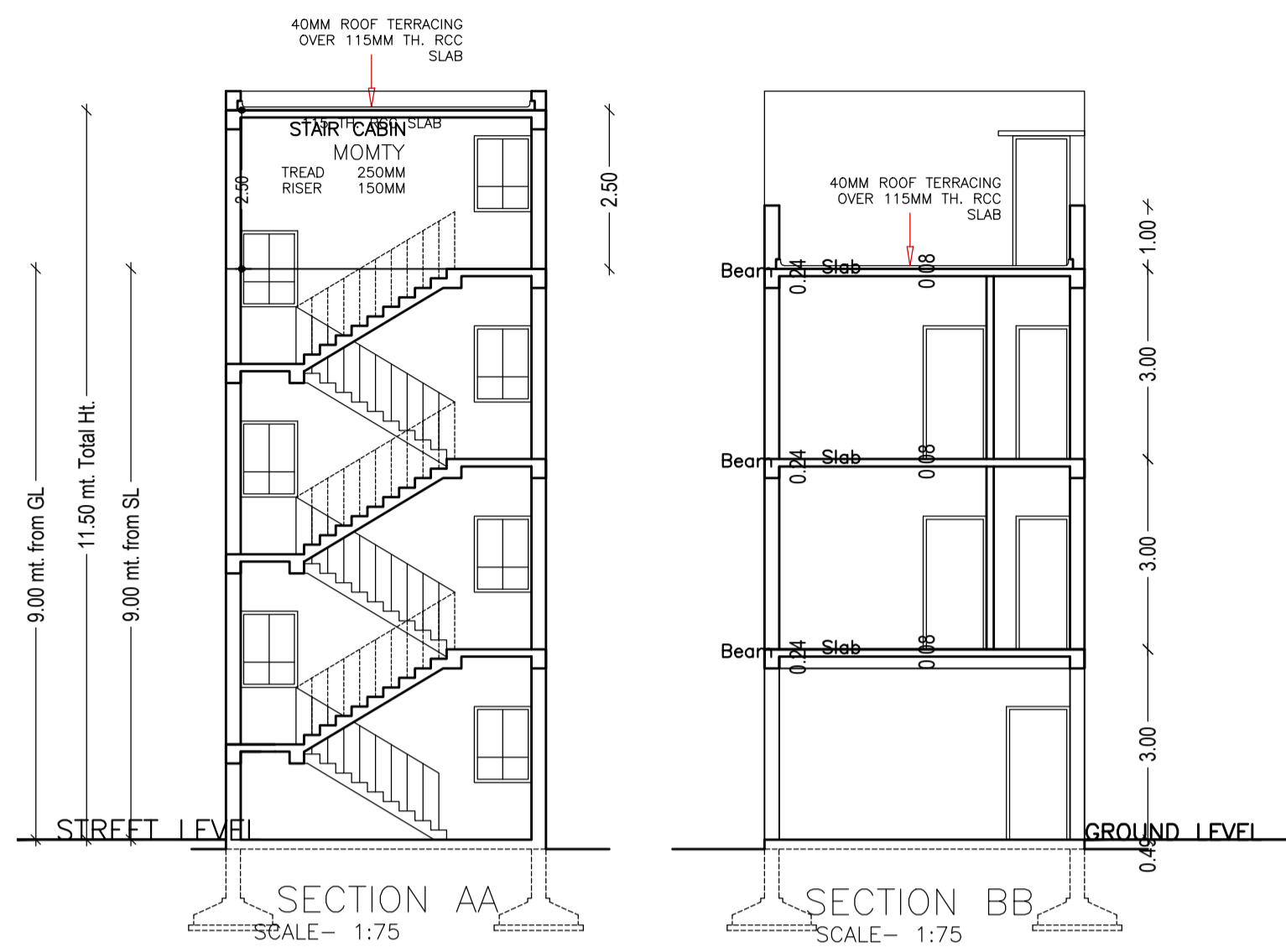

LTP NAME AND SIGNATURE	STRUCTURAL ENG'S NAME AND SIGNATURE	BUILDER NAME AND SIGNATURE	DIGITAL SIGNATURE
Amarjeet Balmuchu JNAC/ARC/0008/2018			