

Proposal Basic Information

Proposal File No.	JNAC/BP/0039/W11/2022
Owner Name	ANAND KUMAR SHARMA AND OTHERS
Khata No	52
Plot No	833
Village Name	Sitaramdera
Use	Residential
SubUse	Bungalow/ Dwelling / Non Apartment

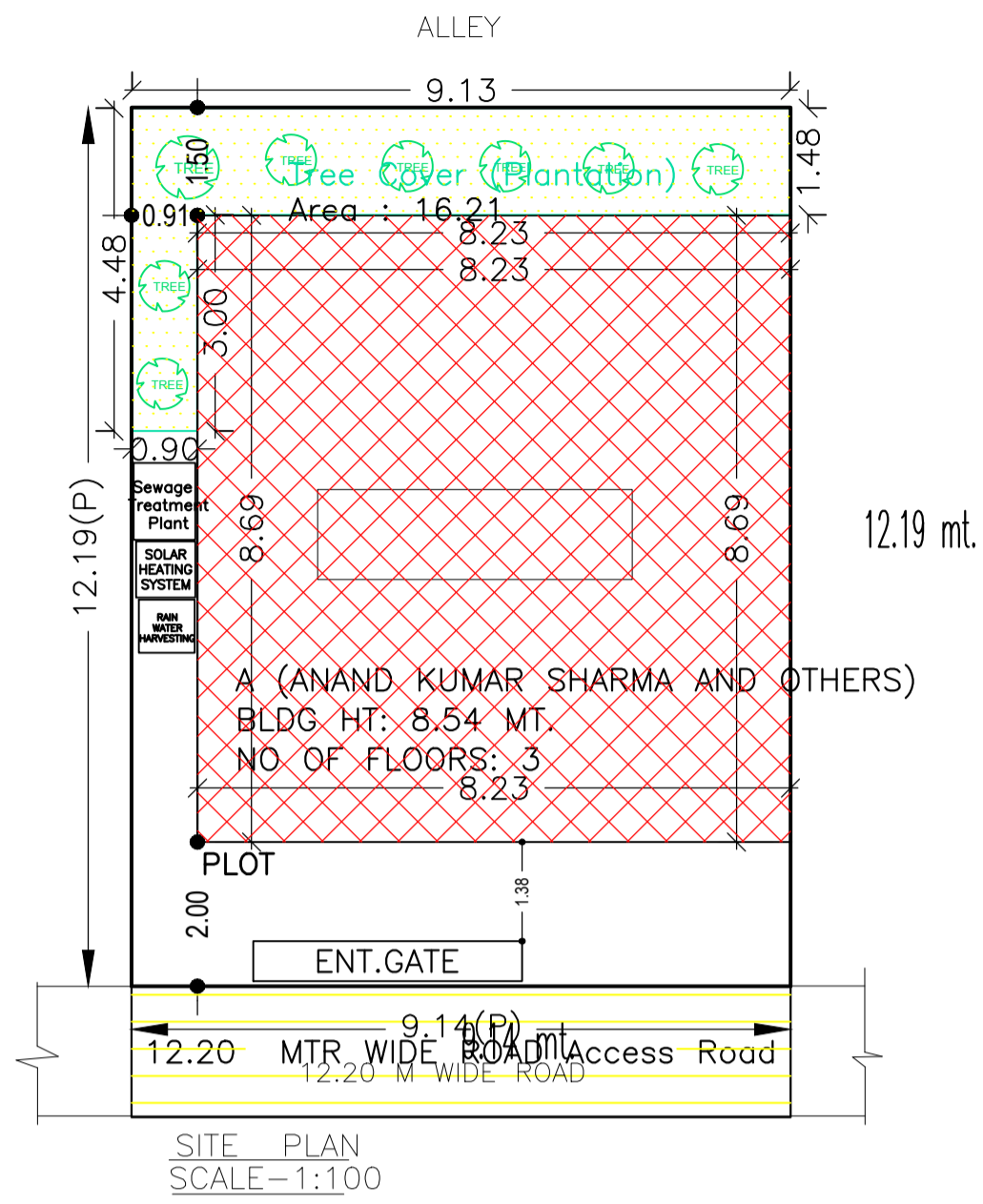

AREA STATEMENT	VERSION NO: 1.0.62		
JAMSHEDPUR NAC	VERSION DATE: 16/10/2020		
PROJECT DETAIL:			
Region: JHARKHAND URBAN LOCAL BODIES	Plot Use: Residential		
District: EAST SINGHBHUM	Plot SubUse: Bungalow/ Dwelling / Non Apartment		
Authority: JAMSHEDPUR NAC	PlotNearby/ReligiousStructure: NA		
Inward_No: JNAC/BP/0039/W11/2022	Plot/SubPlot No: 833		
Application Type: General Proposal	North: -		
Project Type: Building Permission	South: Road Width - 12.20 MTR WIDE MAIN ROAD		
Nature of Development: New	East: -		
Location of Development Area: Old Area	West: -		
AREA DETAILS:			
AREA OF PLOT (Minimum)	(A)	SQ.MT.	111.47
NET AREA OF PLOT(Gross Plot Area - Deduction from Gross Plot area)	(A-Deductions)		111.47
Deduction for Balance Plot Area(from Gross Plot Area)			
Common Plot			16.21
Total			16.21
BALANCE AREA OF PLOT(Net Plot Area - Recreational/Amenity space)	(A-Deductions)		95.26
PLOT AREA FOR COVERAGE(Net Plot Area)	(A-Deductions)		111.47
Plot Area for FAR (Net Plot Area + Road/Widening Area)	(A-Deductions)		111.47
COVERAGE CHECK			
Permissible Coverage area (70.00 %)			78.03
Proposed Coverage Area (64.19 %)			71.55
Total Prop. Coverage Area (64.19 %)			71.55
Balance coverage area (5.81 %)			6.48
FAR CHECK			
Perm. FAR Area (2.50)			278.67
Total Perm. FAR area			278.67
Residential FAR			143.10
Proposed FAR Area			159.30
Total Proposed FAR Area			159.30
Consumed FAR (Factor)			1.43
Balance FAR Area			119.37
BUILT UP AREA CHECK			
Total Proposed BuiltUp Area			214.65
ARCHITECT (Regd)		Amarjeet Balmuchu	
ENGINEER (Regd)			
SUPERVISOR (Regd)			
OWNER (Regd)		ANAND KUMAR SHARMA AND OTHERS	
DEVELOPMENT AUTHORITY		LOCAL BODY	

Building USE/SUBUSE Details

Building Name	Building Use	Building SubUse	Building Structure
A (ANAND KUMAR SHARMA AND OTHERS)	Residential	Bungalow/ Dwelling / Non Apartment	Non-Highrise

FAR & Tenement Details (Table 4c-1)

Building	No. of Same Bldg	Total Built Up Area (Sq.mt.)	Deductions (Area in Sq.mt.)		Proposed FAR Area (Sq.mt.)	Add Area In FAR (Sq.mt.)	Total FAR Area (Sq.mt.)	Total Consumed Additional FAR Area (Sq.mt.)	Tnmt (No.)
			Parking	Resi.					
A (ANAND KUMAR SHARMA AND OTHERS)	1	214.65	55.36	143.10	16.19	159.29	159.29	01	
Grand Total :	1	214.65	55.36	143.10	16.19	159.29	159.29	01	

SITE PLAN

COLOR INDEX	
PLOT BOUNDARY	
ABUTTING ROAD	
PROPOSED CONSTRUCTION	
COMMON PLOT	
ROAD WIDENING AREA	
EXISTING (To be retained)	
EXISTING (To be demolished)	

Buildingwise Floor FAR Details

Floor Name	Building Name		Total	
	Proposed Built Up Area (Sq.mt.)	Proposed FAR Area (Sq.mt.)	Total Proposed Built Up Area (Sq.mt.)	Total FAR Area (Sq.mt.)
Ground Floor	71.55	16.19	71.55	16.19
First Floor	71.55	71.55	71.55	71.55
Second Floor	71.55	71.55	71.55	71.55
Terrace Floor	0.00	0.00	0.00	0.00
Total :	214.65	159.29	214.65	159.29

LTP NAME AND SIGNATURE	STRUCTURAL ENG'S NAME AND SIGNATURE	BUILDER NAME AND SIGNATURE	DIGITAL SIGNATURE
Amarjeet Balmuchu JNAC/ARC/0008/2018			

Proposal Basic Information	
Proposal File No.	JNAC/BP/0039/W11/2022
Owner Name	ANAND KUMAR SHARMA AND OTHERS
Khata No	52
Plot No	833
Village Name	Sitaramdera
Use	Residential
SubUse	Bungalow/ Dwelling / Non Apartment

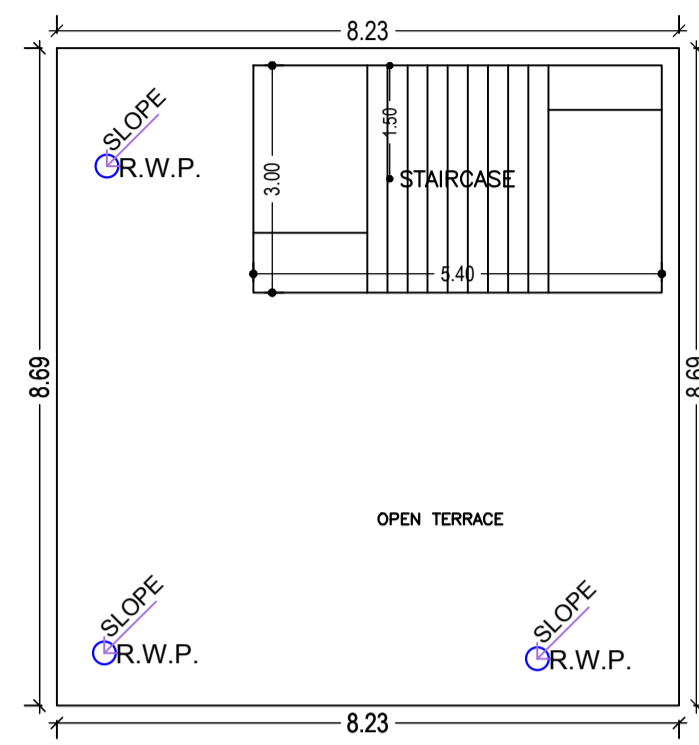
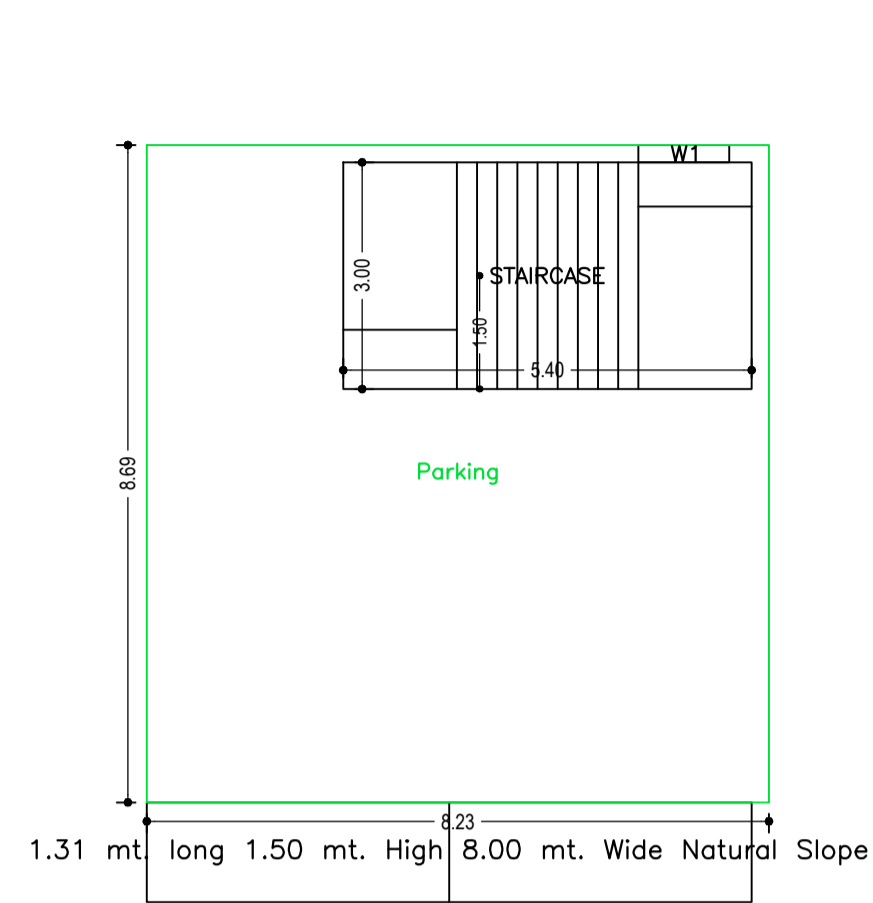

TERRACE FLOOR PLAN
(SCALE 1:100)

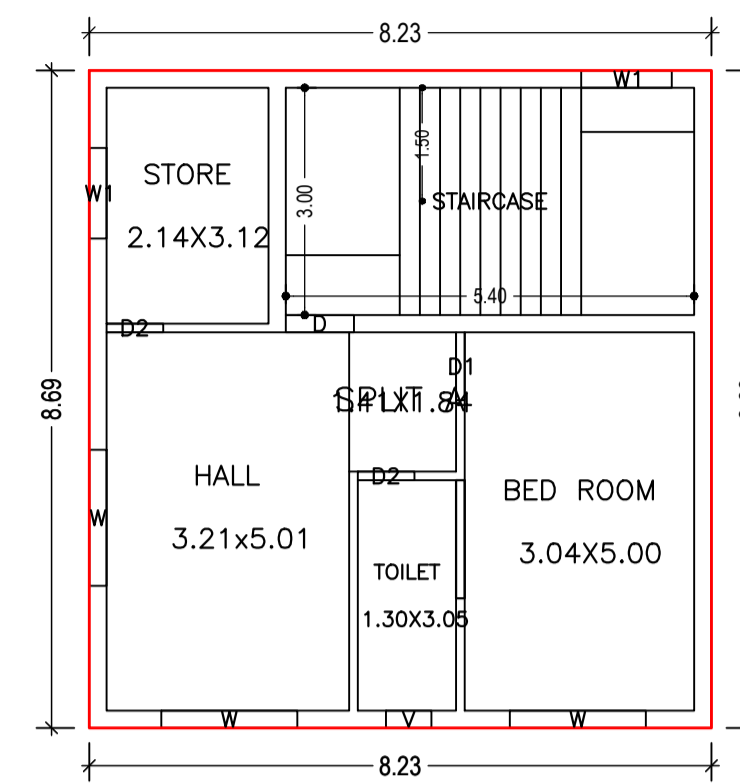

SECOND FLOOR PLAN
(Proposed)
(SCALE 1:100)

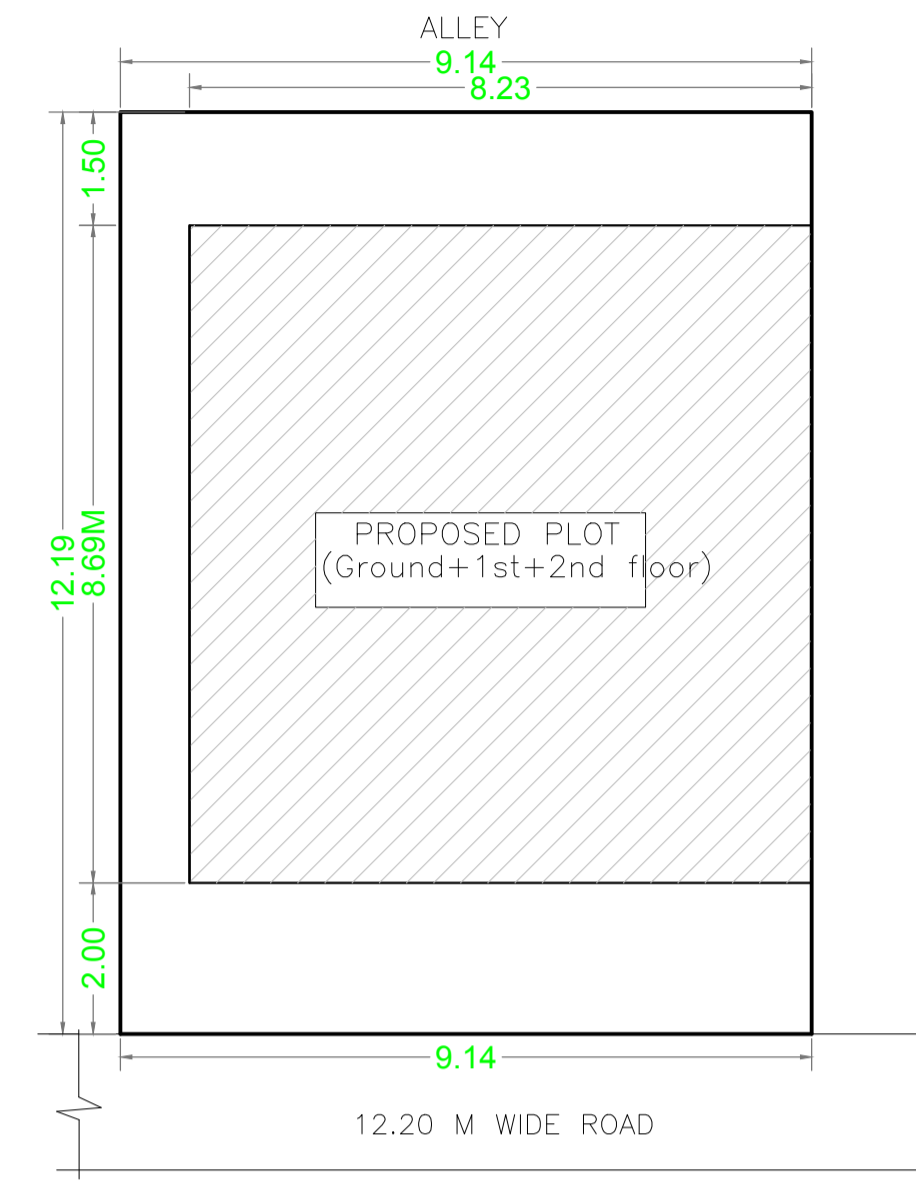

SITE PLAN
SCALE=1:100

GROUND FLOOR PLAN
(SCALE 1:100)

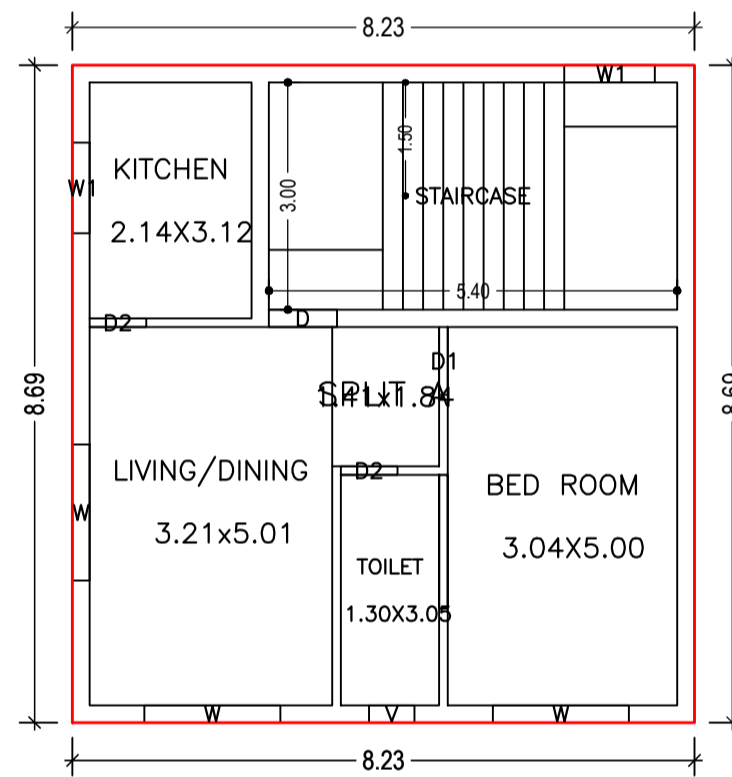

FIRST FLOOR PLAN
(Proposed)
(SCALE 1:100)

Building :A (ANAND KUMAR SHARMA AND OTHERS)

Floor Name	Total Built Up Area (Sq.mt.)	Deductions (Area in Sq.mt.)		Proposed FAR Area (Sq.mt.)		Add Area In FAR (Sq.mt.)	Total FAR Area (Sq.mt.)	Total Consumed Additional FAR Area (Sq.mt.)	Tnmt (No.)
		Parking	Resi.	Stair	Stair				
Ground Floor	71.55	55.36	0.00	16.19	16.19	16.19	16.19	00	
First Floor	71.55	0.00	71.55	0.00	71.55	71.55	71.55	01	
Second Floor	71.55	0.00	71.55	0.00	71.55	71.55	71.55	00	
Terrace Floor	0.00	0.00	0.00	0.00	0.00	0.00	0.00	00	
Total	214.65	55.36	143.10	16.19	159.29	159.29	159.29	01	
Total Number of Same Buildings :	1								
Total :	214.65	55.36	143.10	16.19	159.29	159.29	159.29	01	

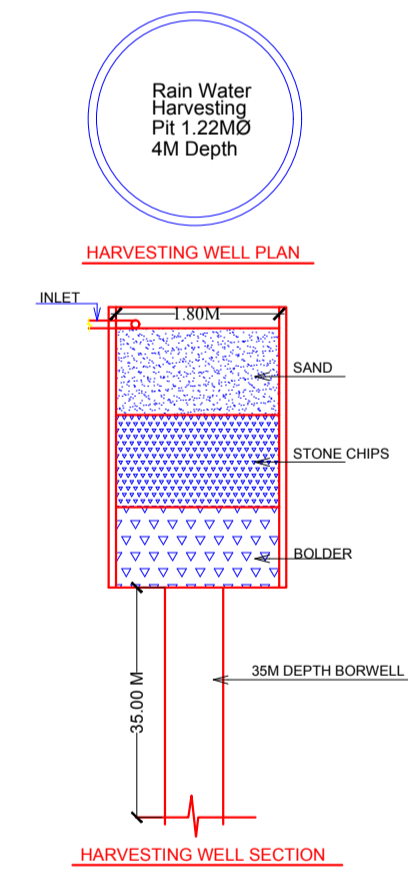

LTP NAME AND SIGNATURE	STRUCTURAL ENG'S NAME AND SIGNATURE	BUILDER NAME AND SIGNATURE	DIGITAL SIGNATURE
Amarjeet Balmuchu JNAC/ARC/0008/2018			

Proposal Basic Information	
Proposal File No.	JNAC/BP/0039/W11/2022
Owner Name	ANAND KUMAR SHARMA AND OTHERS
Khata No	52
Plot No	833
Village Name	Sitaramdera
Use	Residential
SubUse	Bungalow/ Dwelling / Non Apartment

SCHEDULE OF DOOR:

BUILDING NAME	NAME	LENGTH	HEIGHT	NOS
A (ANAND KUMAR SHARMA AND OTHERS)	D2	0.75	2.13	04
A (ANAND KUMAR SHARMA AND OTHERS)	D1	0.90	2.13	02
A (ANAND KUMAR SHARMA AND OTHERS)	D	0.90	2.13	02

SCHEDULE OF WINDOW/VENTILATION:

BUILDING NAME	NAME	LENGTH	HEIGHT	NOS
A (ANAND KUMAR SHARMA AND OTHERS)	V	0.60	2.70	02
A (ANAND KUMAR SHARMA AND OTHERS)	W1	1.20	2.70	05
A (ANAND KUMAR SHARMA AND OTHERS)	W	1.80	2.70	06

UnitBUA Table for Building :A (ANAND KUMAR SHARMA AND OTHERS)

FLOOR	Name	UnitBUA Type	UnitBUA Area	Carpet Area	No. of Rooms	No. of Tenement
FIRST FLOOR PLAN	SPLIT A	FLAT	91.65	91.27	4	1
SECOND FLOOR PLAN	SPLIT A	FLAT	0.00	0.00	4	0
Total	-	-	91.65	91.27	8	1

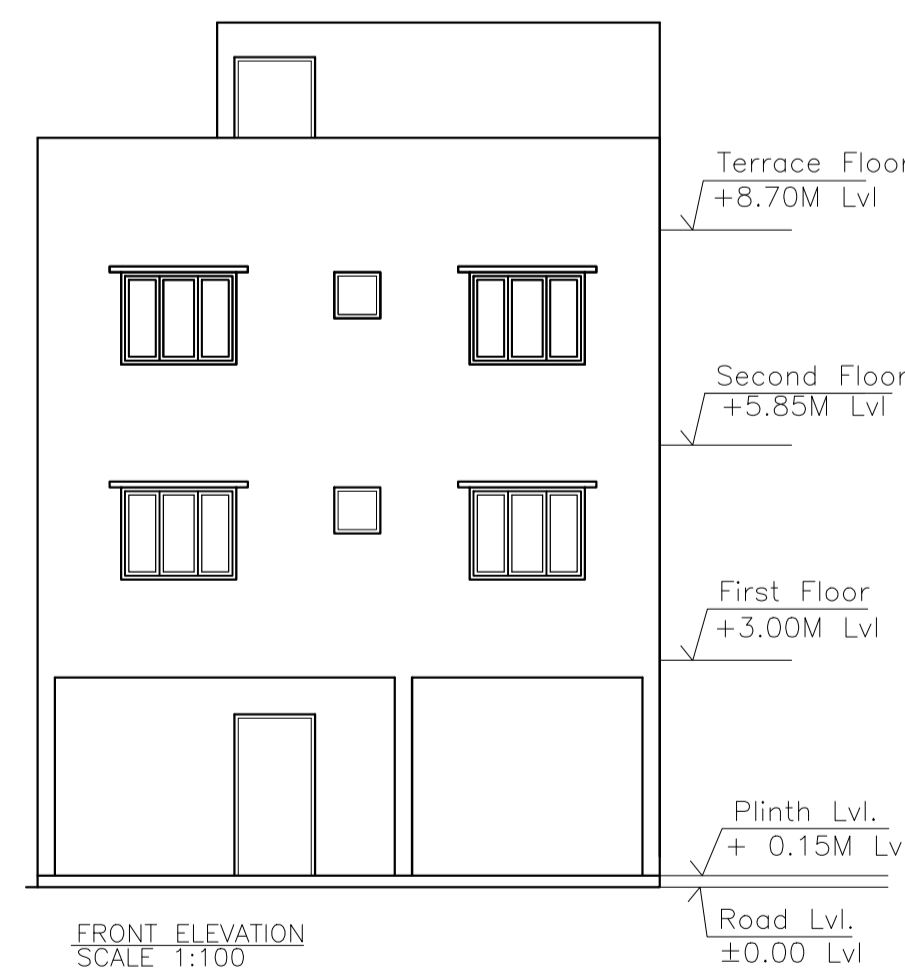
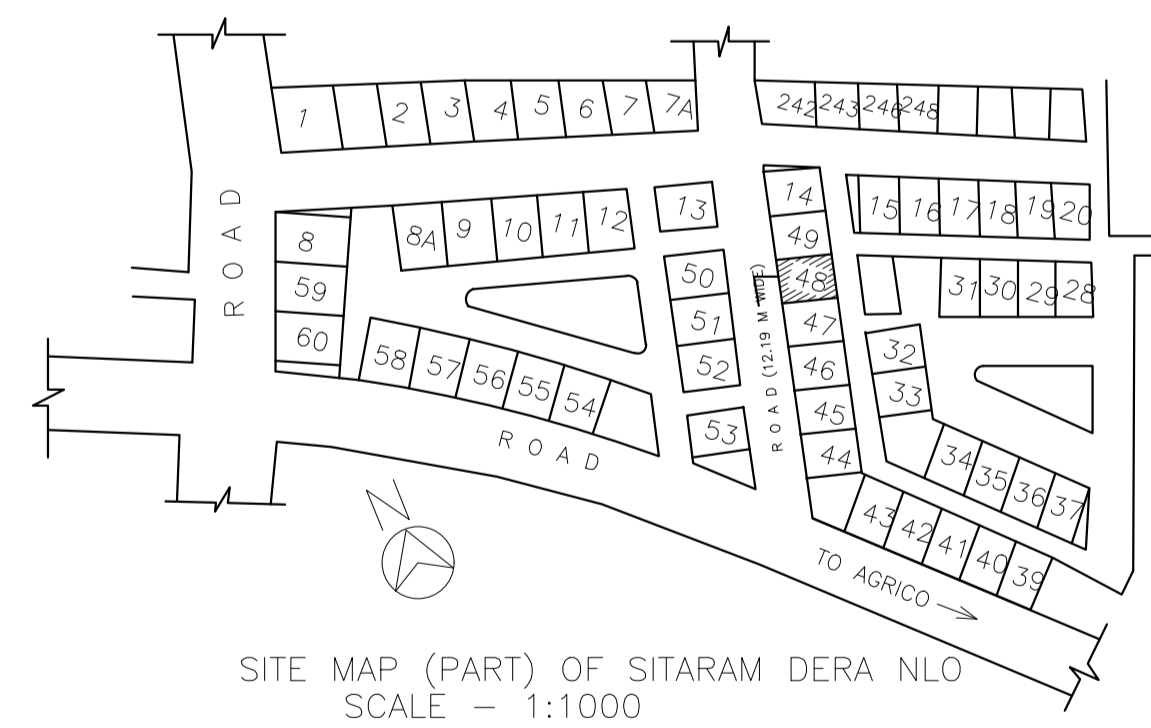
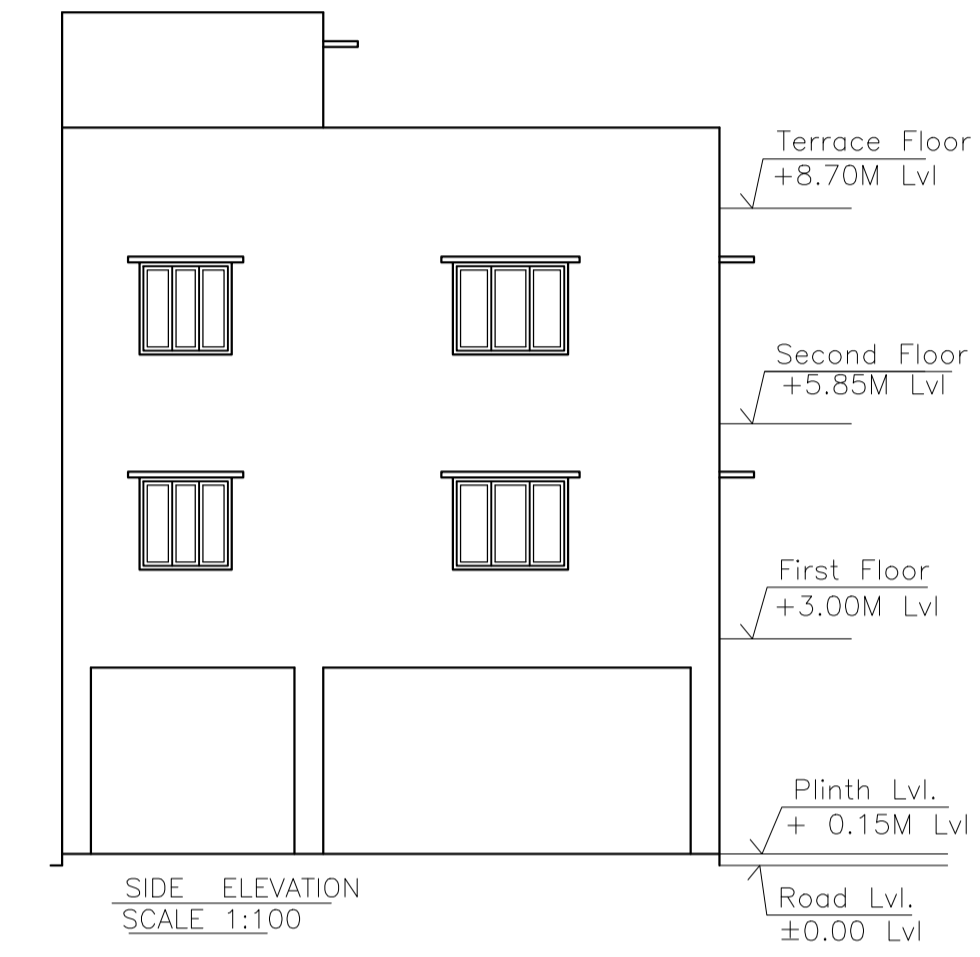
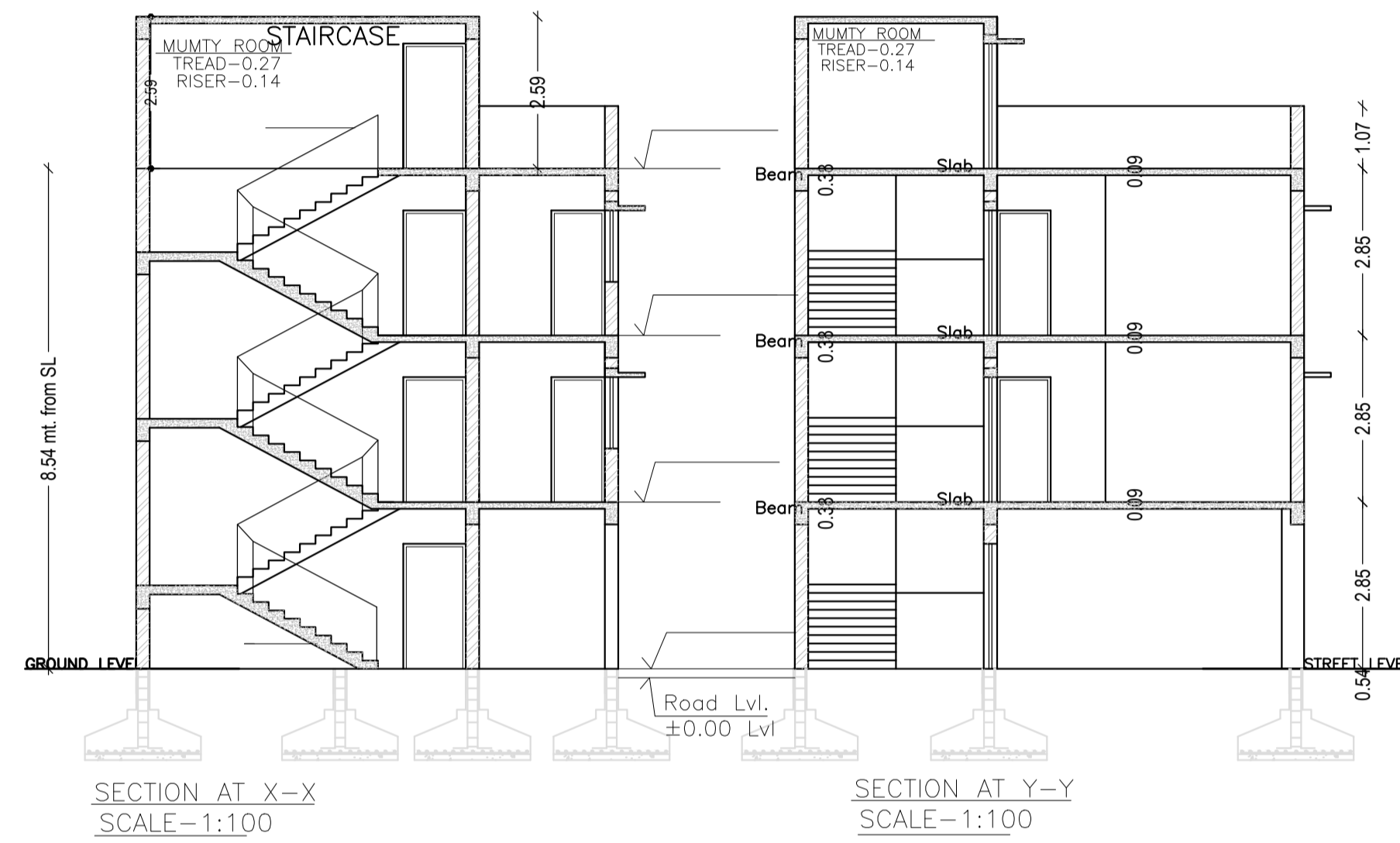

LTP NAME AND SIGNATURE	STRUCTURAL ENG'S NAME AND SIGNATURE	BUILDER NAME AND SIGNATURE	DIGITAL SIGNATURE
Amarjeet Balmuchu JNAC/ARC/0008/2018			