

Proposal Basic Information	
Proposal File No.	JNAC/BP/0123/W1/2022
Owner Name	MRS USHA SINGH
Khata No	622
Plot No	3398 (SUB PLOT NO-57)
Village Name	SONARI
Use	Residential
SubUse	Bungalow/ Dwelling / Non Apartment

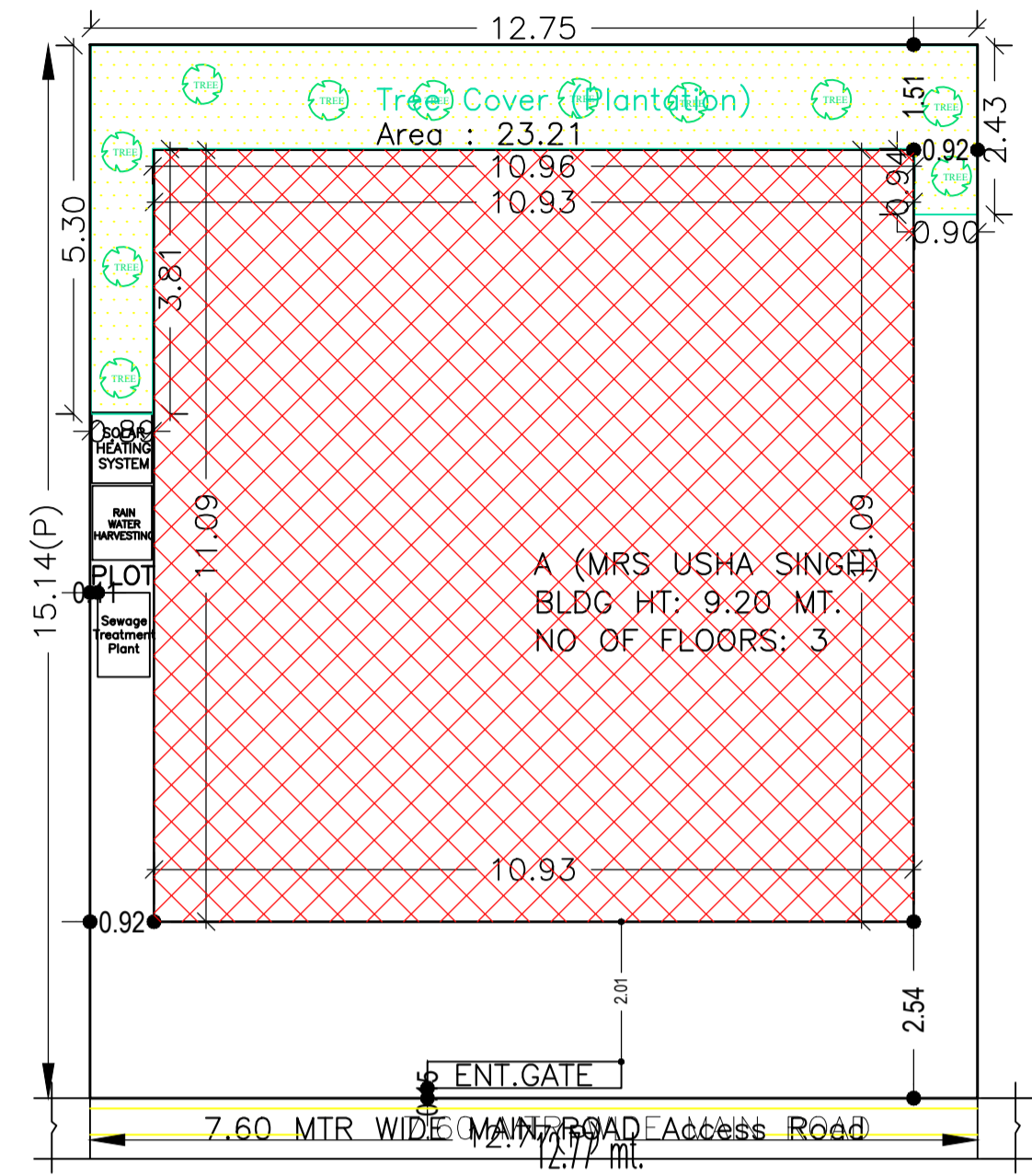

15.14 mt.

1.50 mt. long 1.50 mt. High 3.70 mt. Wide Natural Slope

GROUND FLOOR PLAN (Proposed) (SCALE 1:100)

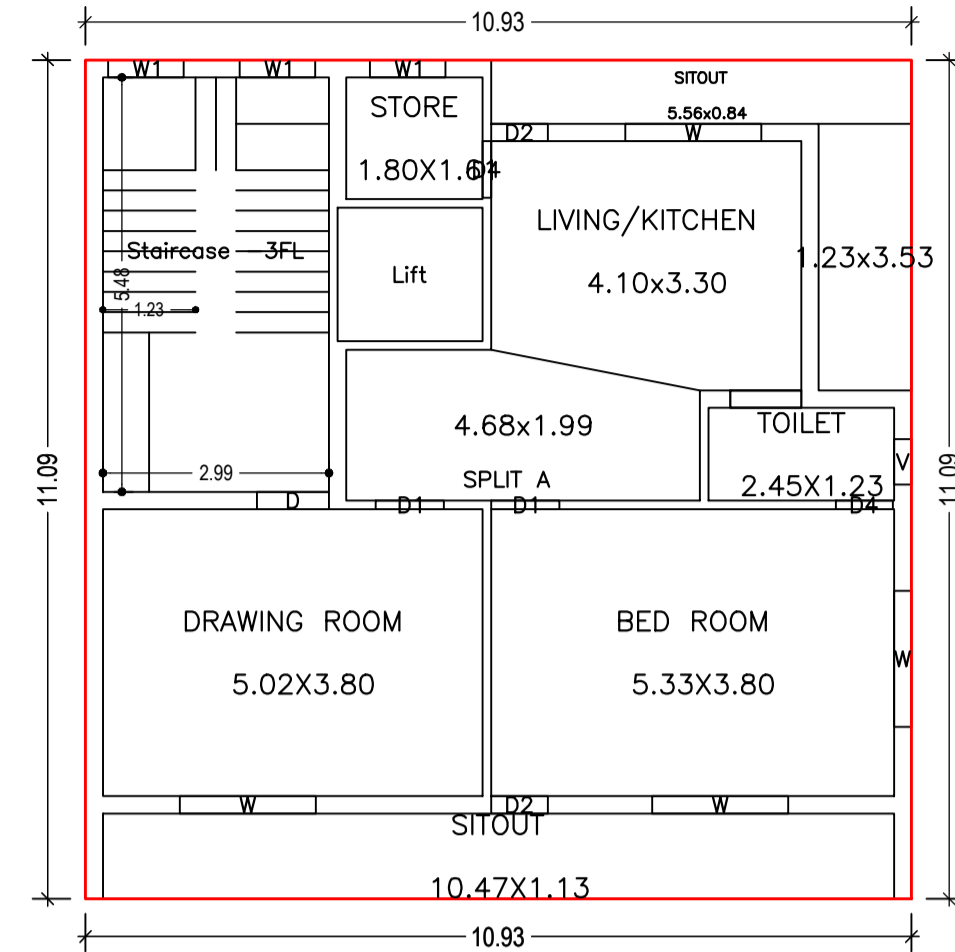

FIRST FLOOR PLAN (Proposed) (SCALE 1:100)

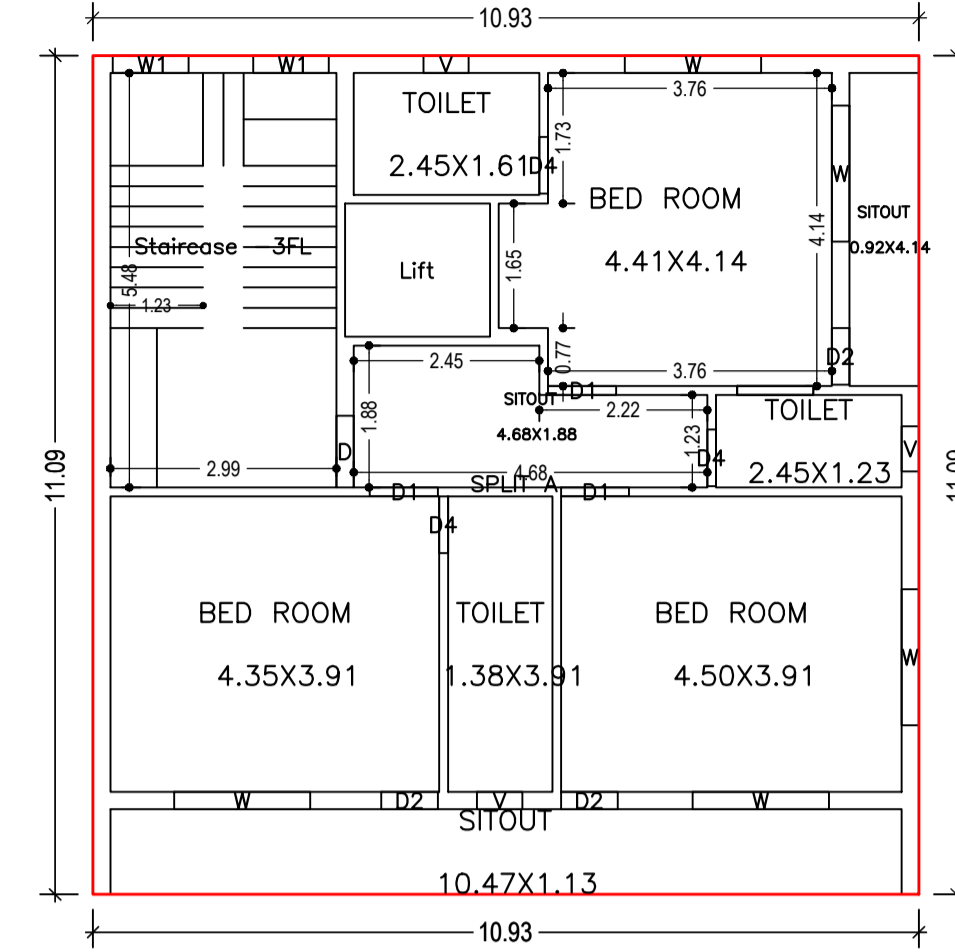

SECOND FLOOR PLAN (Proposed) (SCALE 1:100)

AREA STATEMENT		VERSION NO. : 1.0.65
JAMSHEDPUR NAC		VERSION DATE: 16/10/2020
PROJECT DETAIL:		
Region: JHARKHAND URBAN LOCAL BODIES	Plot Use: Residential	
District: EAST SINGHBHUM	Plot SubUse: Bungalow/ Dwelling / Non Apartment	
Authority: JAMSHEDPUR NAC	PlotNearby/ReligiousStructure: NA	
Inward No: JNAC/BP/0123/W1/2022	Plot/SubPlot No: 3398 (SUB PLOT NO-57)	
Application Type: General Proposal	North: Road Width - 7.60 MTR WIDE MAIN ROAD	
Project Type: Building Permission	South: -	
Nature of Development: New	East: -	
Location of Development Area: Old Area	West: -	
AREA DETAILS:		
AREA OF PLOT (Minimum)	(A)	SQ. MT.
NET AREA OF PLOT(Gross Plot Area - Deduction from Gross Plot area)	(A-Deductions)	193.30
Deduction for Balance Plot Area(from Gross Plot Area)		
Common Plot		23.21
BALANCE AREA OF PLOT(Net Plot Area - Recreational/Amenity space)	(A-Deductions)	170.09
PLOT AREA FOR COVERAGE(Net Plot Area)	(A-Deductions)	193.30
Plot Area for FAR (Net Plot Area + RoadWidening Area)	(A-Deductions)	193.30
COVERAGE CHECK		
Permissible Coverage area (70.00 %)		135.31
Proposed Coverage Area (62.69 %)		121.19
Total Prop. Coverage Area (62.69 %)		121.19
Balance coverage area (7.30 %)		14.12
FAR CHECK		
Perm. FAR Area (2.500)		483.25
Total Perm. FAR area		483.25
Residential FAR		277.54
Proposed FAR Area		294.60
Total Proposed FAR Area		294.60
Consumed FAR (Factor)		1.52
Balance FAR Area		188.65
BUILT UP AREA CHECK		
Total Proposed BuiltUp Area		363.58
ARCHITECT (Regd)	Anoop Kumar	
ENGINEER (Regd)		
SUPERVISOR (Regd)		
OWNER (Regd)	MRS USHA SINGH	
DEVELOPMENT AUTHORITY		LOCAL BODY

SITE PLAN SCALE:1:100

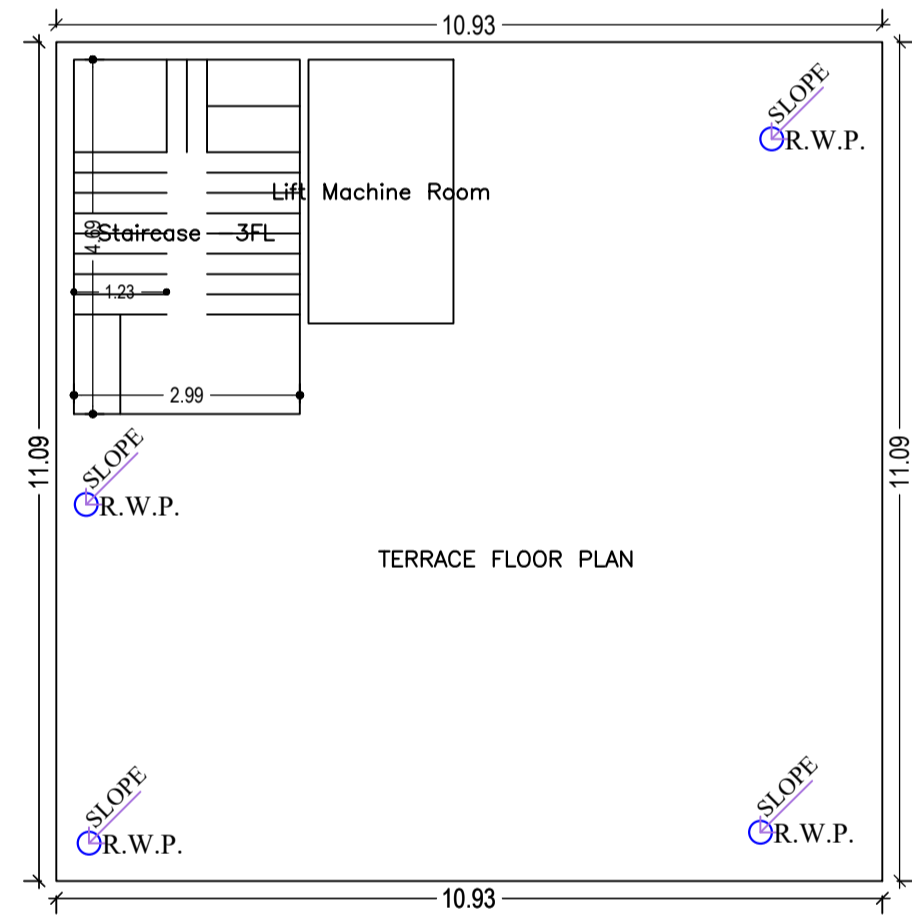

TERRACE FLOOR PLAN (SCALE 1:100)

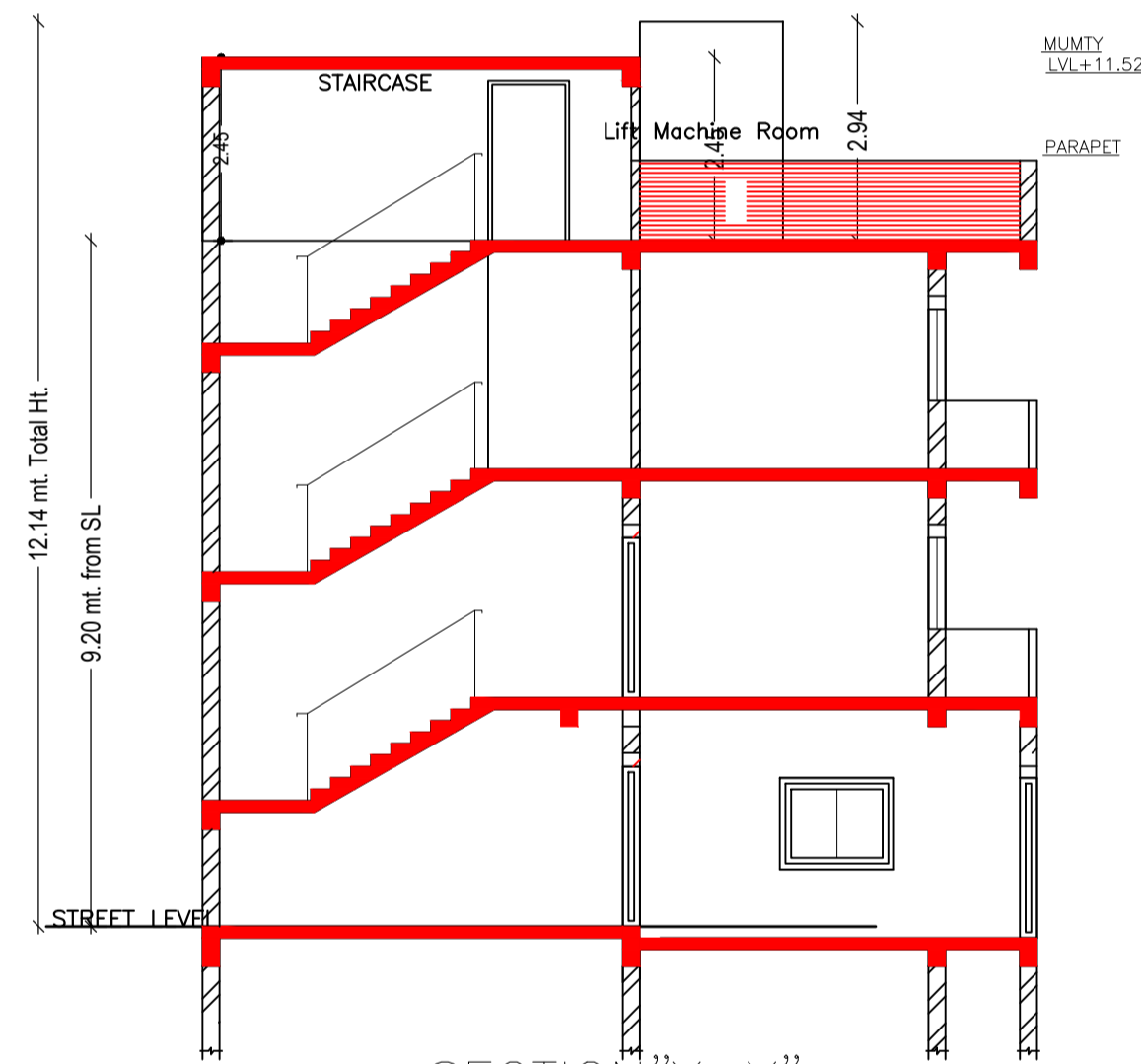

SECTION 'Y-Y' SCALE:1:100

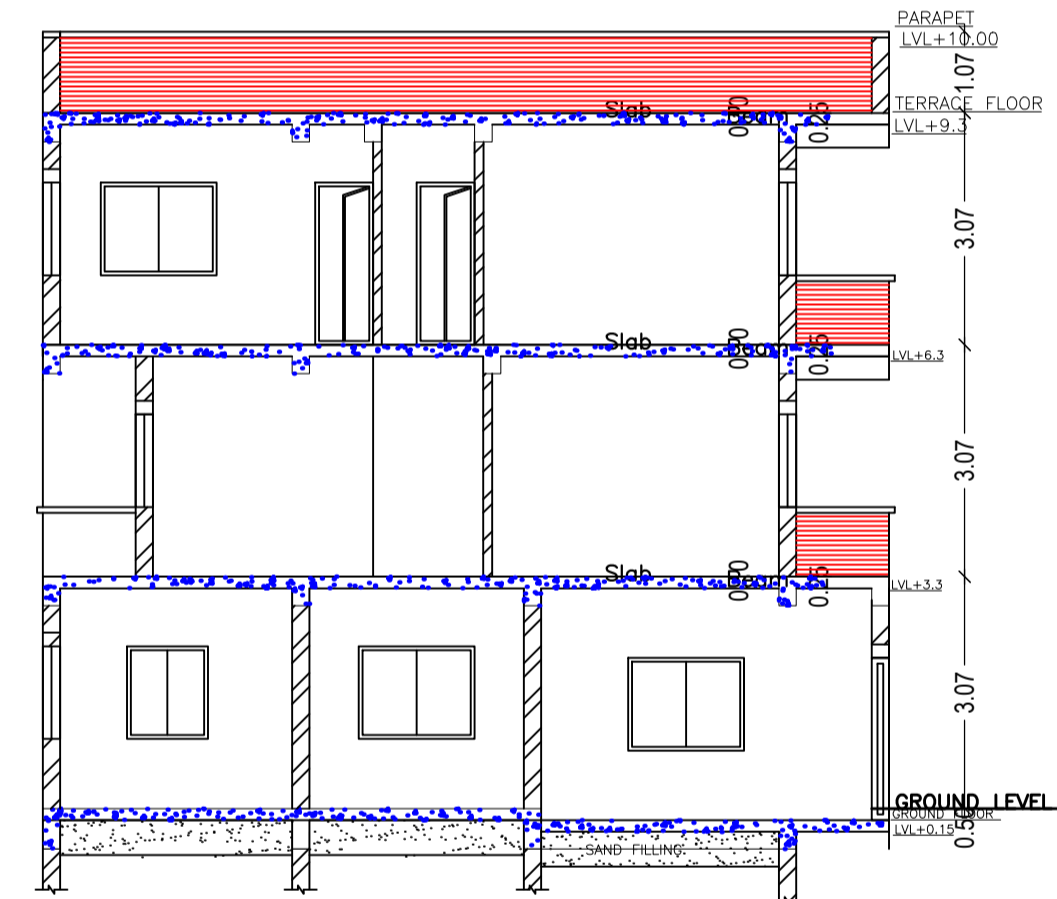

SECTION X-X SCALE:1:100

COLOR INDEX	
PLOT BOUNDARY	Black
ABUTTING ROAD	Green
PROPOSED CONSTRUCTION	Red
COMMON PLOT	Yellow
ROAD WIDENING AREA	Blue
EXISTING (To be retained)	Orange
EXISTING (To be demolished)	Light Blue

Building :A (MRS USHA SINGH)

Floor Name	Total Built Up Area (Sq.mt.)	Deductions (Area in Sq.mt.)				Proposed FAR Area (Sq.mt.)	Add Area In FAR (Sq.mt.)	Total FAR Area (Sq.mt.)	Total Consumed Additional FAR Area (Sq.mt.)	Trmt (No.)
		Lift	Parking	Resi.	Stair					
Ground Floor	121.20	0.00	62.23	41.91	13.68	58.97		58.97	01	
First Floor	121.19	3.38	0.00	117.81	0.00	117.81		117.81	00	
Second Floor	121.19	3.38	0.00	117.81	0.00	117.81		117.81	00	
Terrace Floor	0.00	0.00	0.00	0.00	0.00	0.00		0.00	00	
Total :	363.58	6.76	62.23	277.53	13.68	294.59		294.59	01	
Total Number of Same Buildings	1									
Total :	363.58	6.76	62.23	277.53	13.68	294.59		294.59	01	

UnitBUA Table for Building :A (MRS USHA SINGH)

FLOOR	Name	UnitBUA Type	UnitBUA Area	Carpet Area	No. of Rooms	No. of Tenement
GROUND FLOOR PLAN	SPLIT A	FLAT	222.26	221.53	3	1
FIRST FLOOR PLAN	SPLIT A	FLAT	0.00	0.00	7	0
SECOND FLOOR PLAN	SPLIT A	FLAT	0.00	0.00	9	0
Total:	-	-	222.26	221.53	19	1

SCHEDULE OF DOOR:

BUILDING NAME	NAME	LENGTH	HEIGHT	NOS
A (MRS USHA SINGH)	D2	0.75	2.13	05
A (MRS USHA SINGH)	D4	0.75	2.13	06
A (MRS USHA SINGH)	D1	0.90	2.13	05
A (MRS USHA SINGH)	D	0.95	2.13	02
A (MRS USHA SINGH)	D3	1.07	2.13	02

SCHEDULE OF WINDOW/VENTILATION:

BUILDING NAME	NAME	LENGTH	HEIGHT	NOS
A (MRS USHA SINGH)	V	0.60	2.70	04
A (MRS USHA SINGH)	W1	1.00	2.70	08
A (MRS USHA SINGH)	W	1.80	2.70	11

Buildingwise Floor FAR Details

Floor Name	Building Name		Total	
	Proposed Built Up Area (Sq.mt.)	Proposed FAR Area (Sq.mt.)	Total Proposed Built Up Area (Sq.mt.)	Total FAR Area (Sq.mt.)
Ground Floor	121.20	58.97	121.20	58.97
First Floor	121.19	117.81	121.19	117.81
Second Floor	121.19	117.81	121.19	117.81
Terrace Floor	0.00	0.00	0.00	0.00
Total :	363.58	294.59	363.58	294.59

FAR & Tenement Details (Table 4c-1)

Building	No. of Same Bldg	Total Built Up Area (Sq.mt.)	Deductions (Area in Sq.mt.)				Proposed FAR Area (Sq.mt.)	Add Area In FAR (Sq.mt.)	Total FAR Area (Sq.mt.)	Total Consumed Additional FAR Area (Sq.mt.)	Trmt (No.)
			Lift	Parking	Resi.	Stair					
A (MRS USHA SINGH)	1	363.58	6.76	62.23	277.53	13.68	294.59	294.59	01		
Grand Total	1	363.58	6.76	62.23	277.53	13.68	294.59	294.59	01		

Building USE/SUBUSE Details

Building Name	Building Use	Building SubUse	Building Structure
A (MRS USHA SINGH)	Residential	Bungalow/ Dwelling / Non Apartment	Non-Highrise

LTP NAME AND SIGNATURE	STRUCTURAL ENG'S NAME AND SIGNATURE	BUILDER NAME AND SIGNATURE	DIGITAL SIGNATURE
Anoop Kumar JNAC/ENG/0005/2016			

Proposal Basic Information	
Proposal File No.	JNAC/BP/0123/W1/2022
Owner Name	MRS USHA SINGH
Khata No	622
Plot No	3398 (SUB PLOT NO- 57)
Village Name	SONARI
Use	Residential
SubUse	Bungalow/ Dwelling / Non Apartment

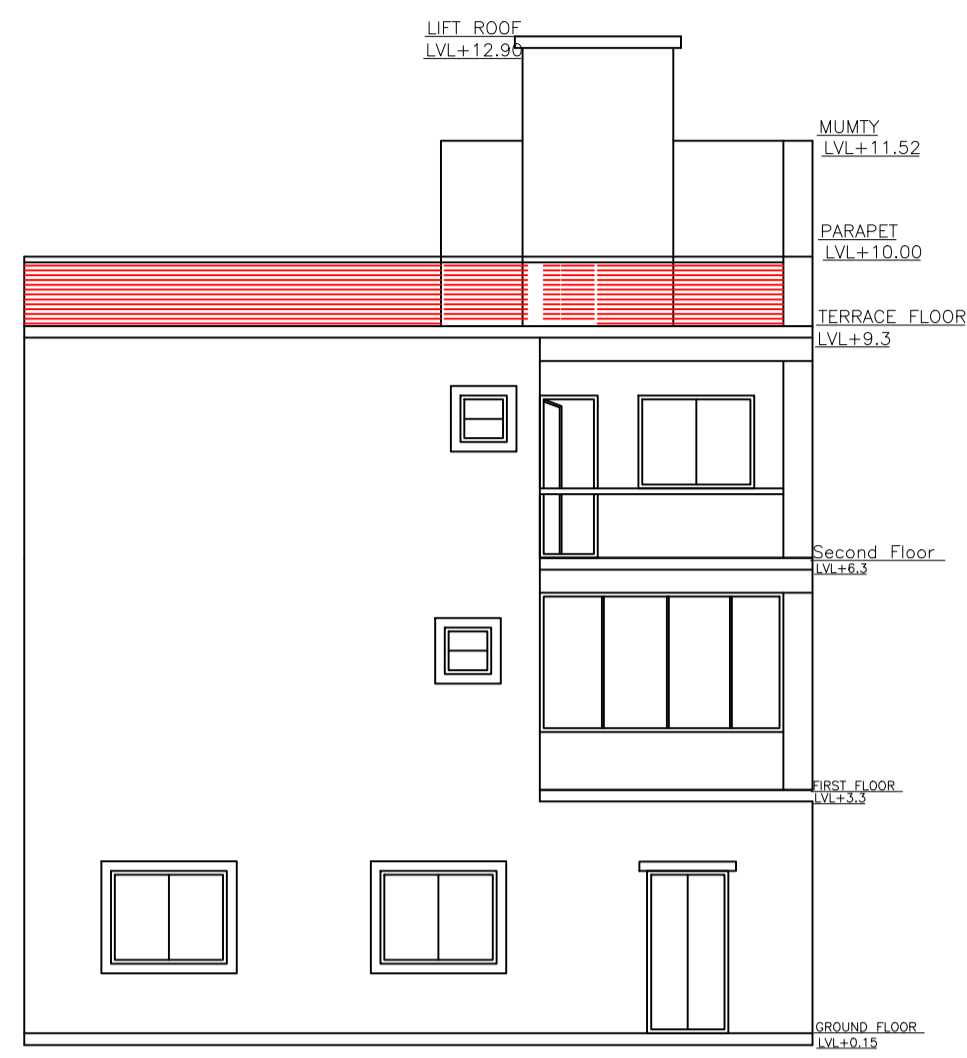

SIDE ELVATION
SCALE:1:100

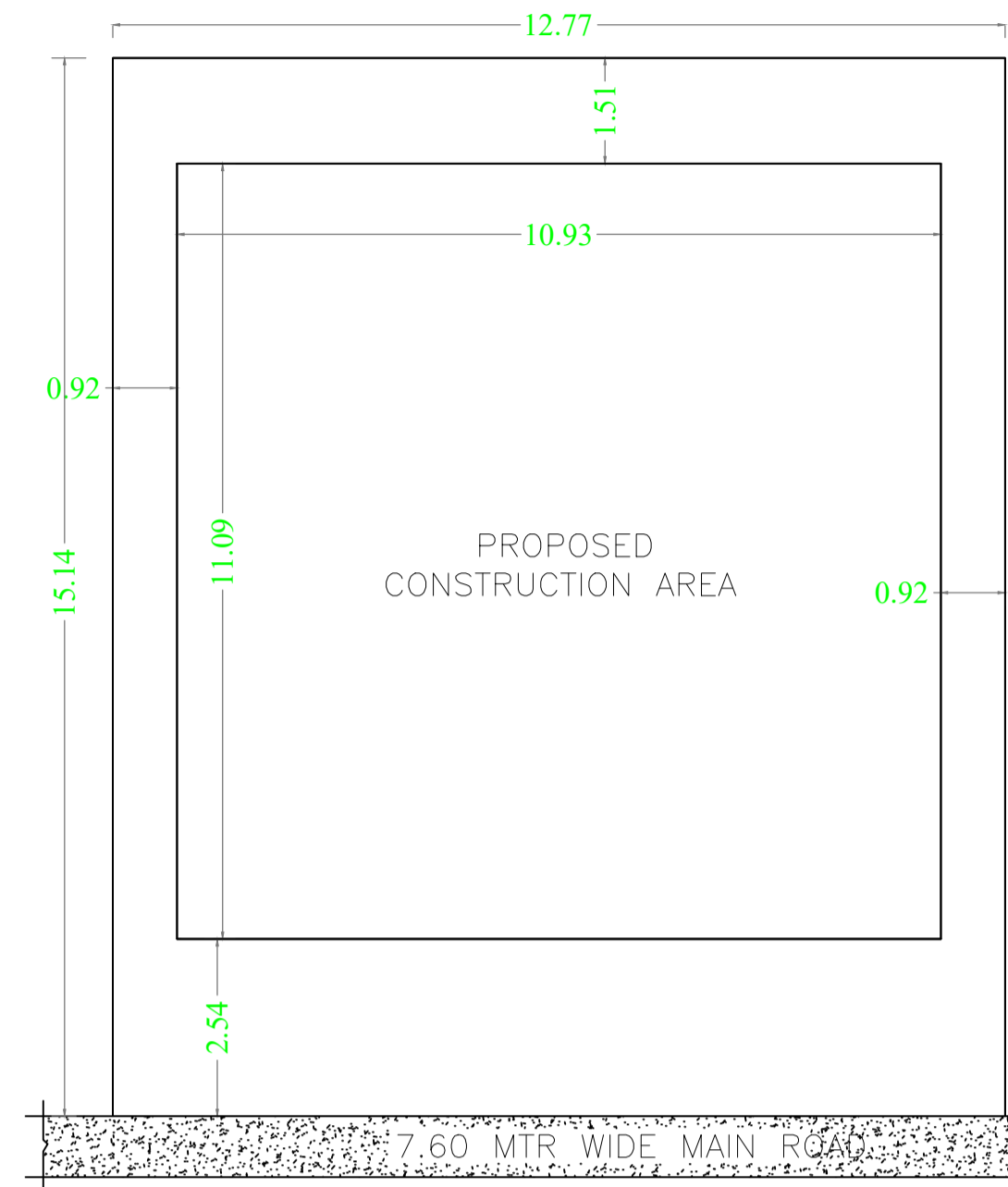

SITE PLAN
SCALE:1:100

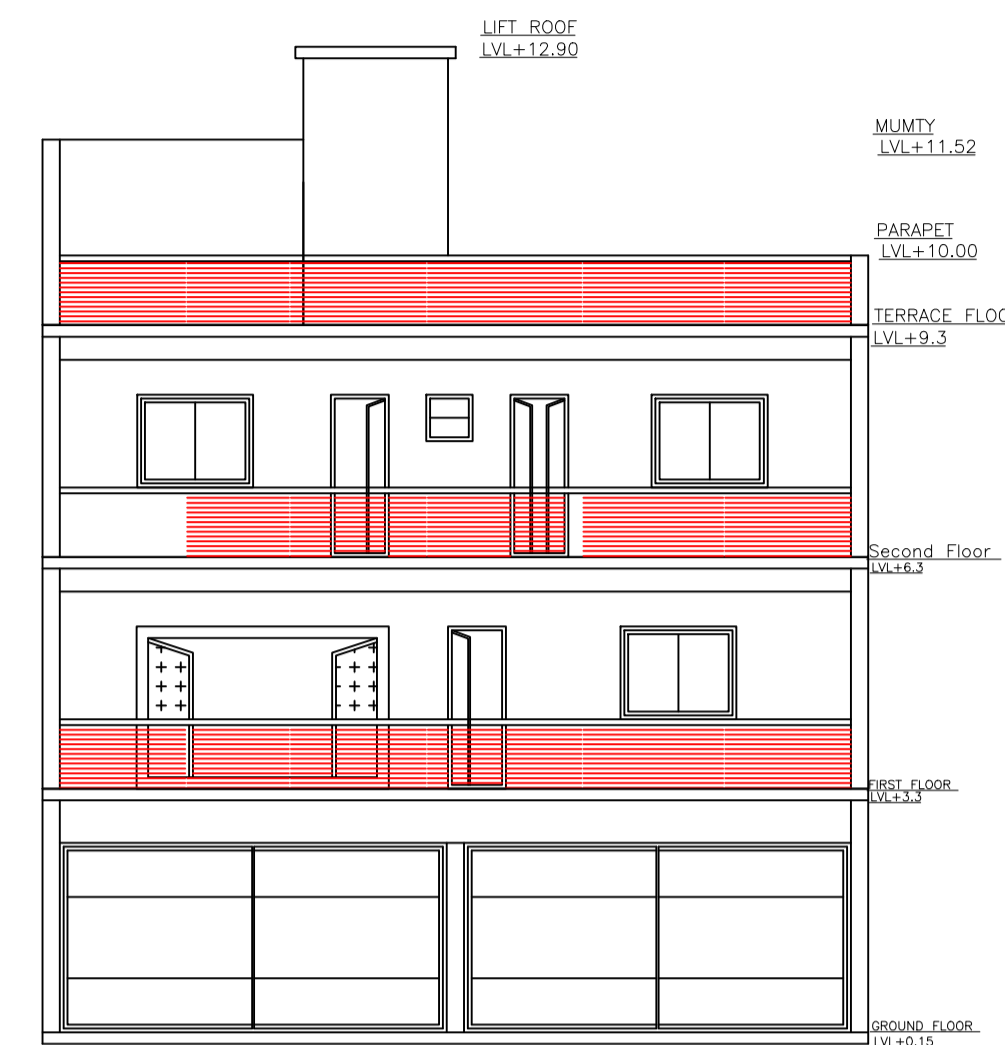

FRONT ELVATION
SCALE:1:100

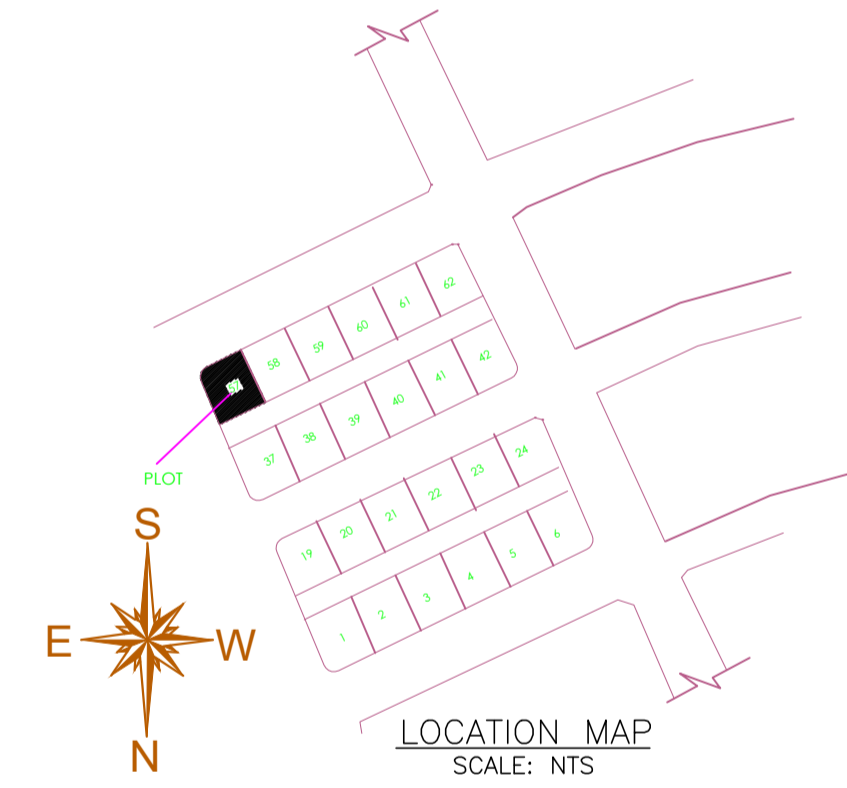
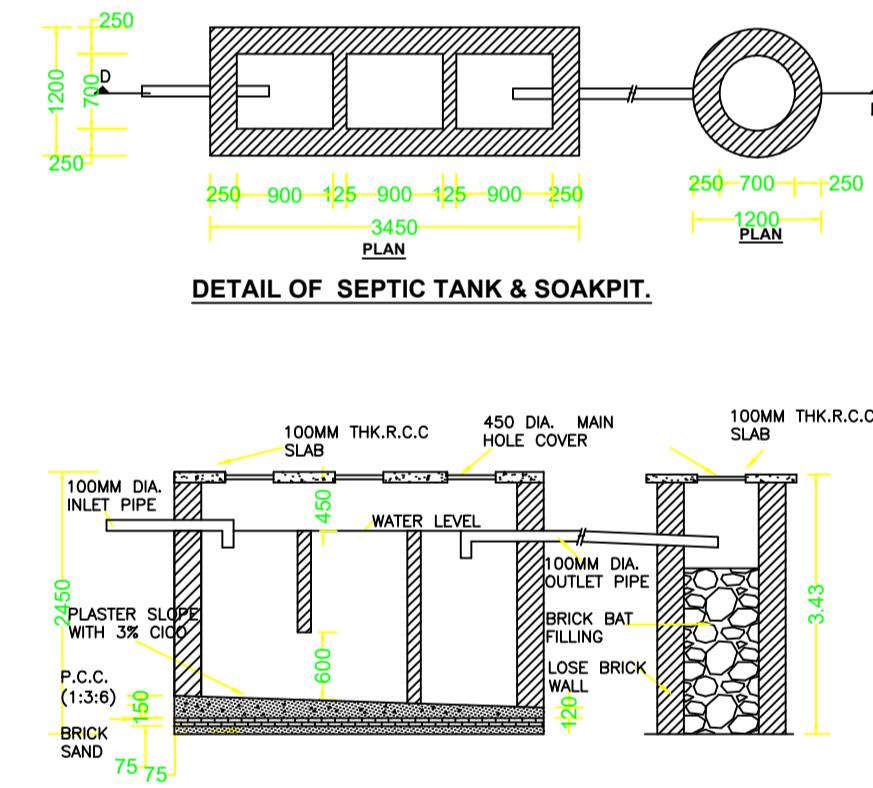
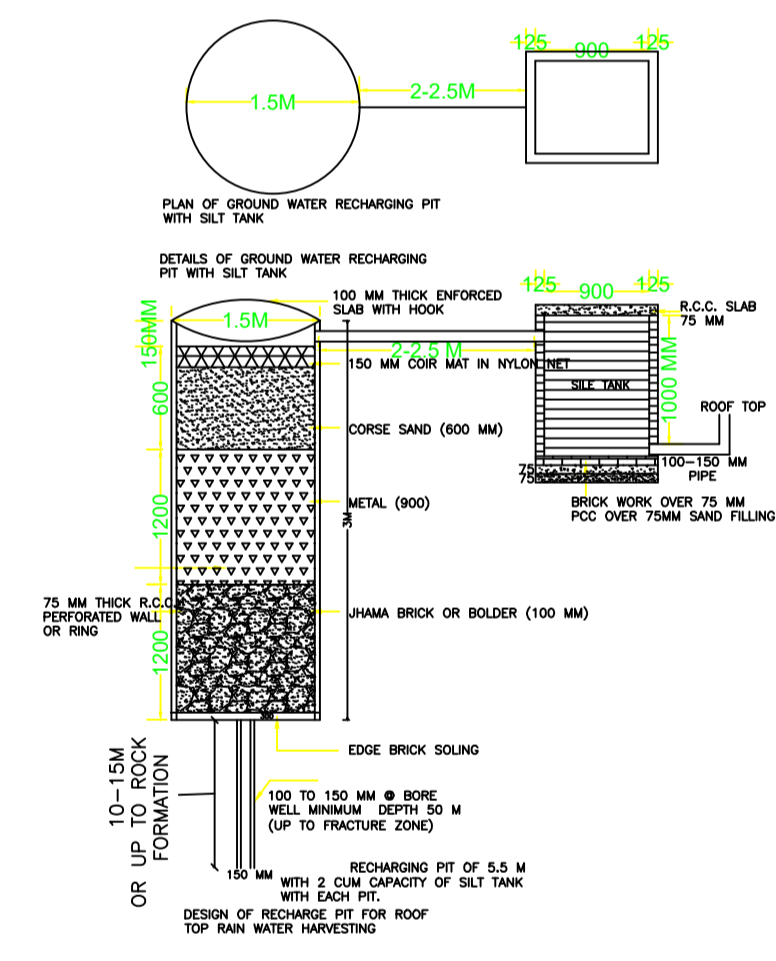
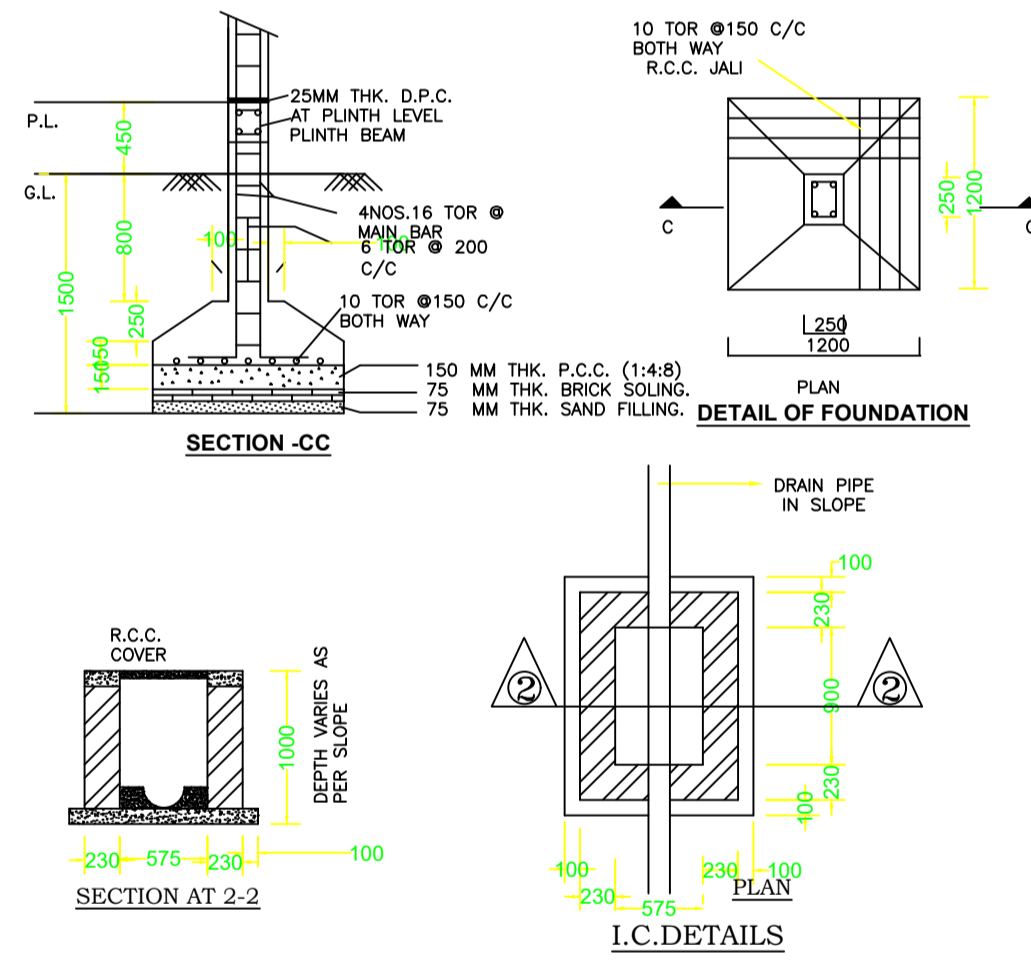

LOCATION MAP
SCALE: NTS

LTP NAME AND SIGNATURE	STRUCTURAL ENG'S NAME AND SIGNATURE	BUILDER NAME AND SIGNATURE	DIGITAL SIGNATURE
Anoop Kumar JNAC/ENG/0005/2016			