

Proposal Basic Information	
Proposal File No.	JNAC/BP/0002/W11/2023
Owner Name	GENDA LAL SHAH AND OTHERS
Khata No	NIL
Plot No	110
Village Name	Sitaramdera
Use	Residential
SubUse	Row House

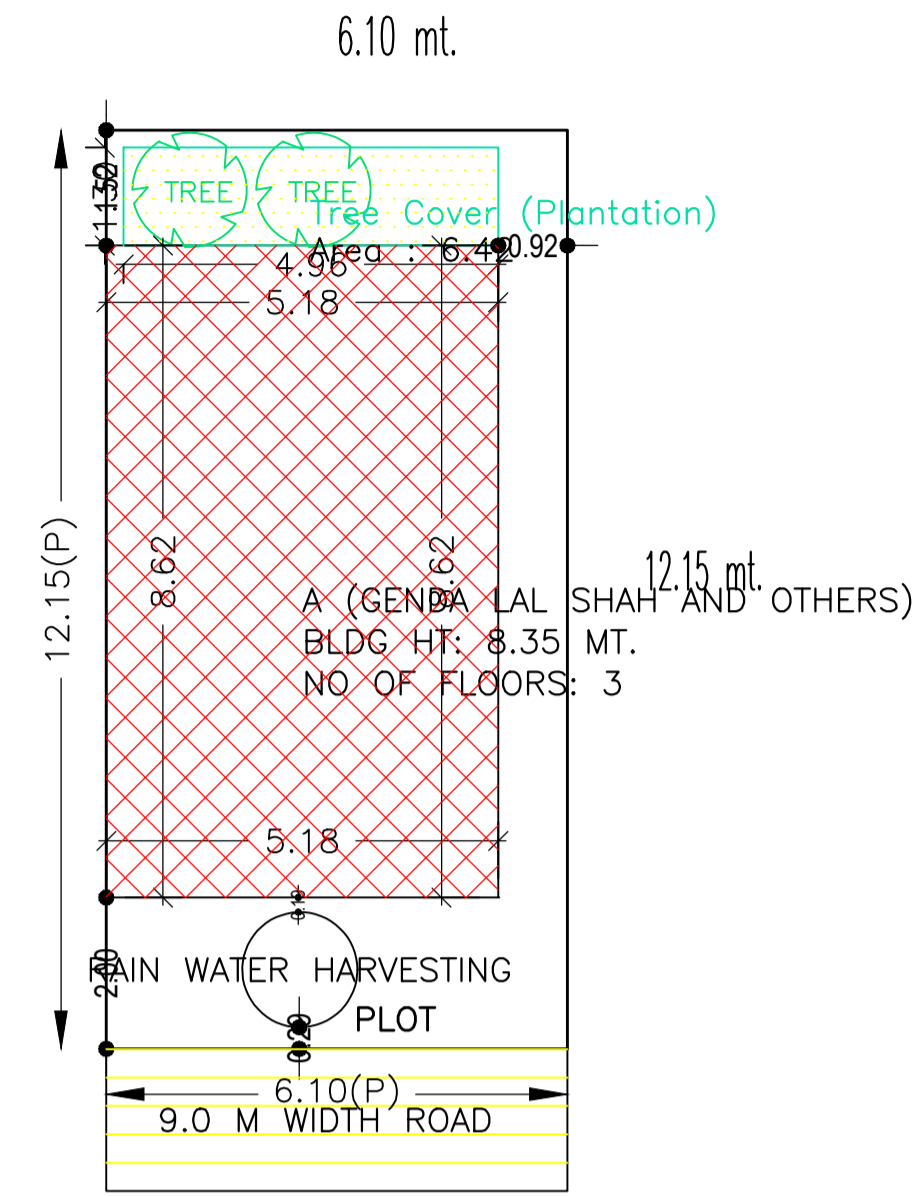

KEY PLAN
SCALE(1:200)

SITE PLAN

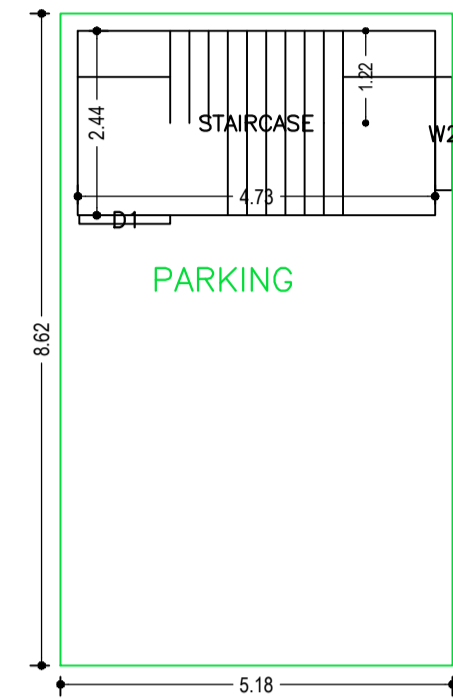

PARKING FLOOR PLAN
(SCALE 1:100)

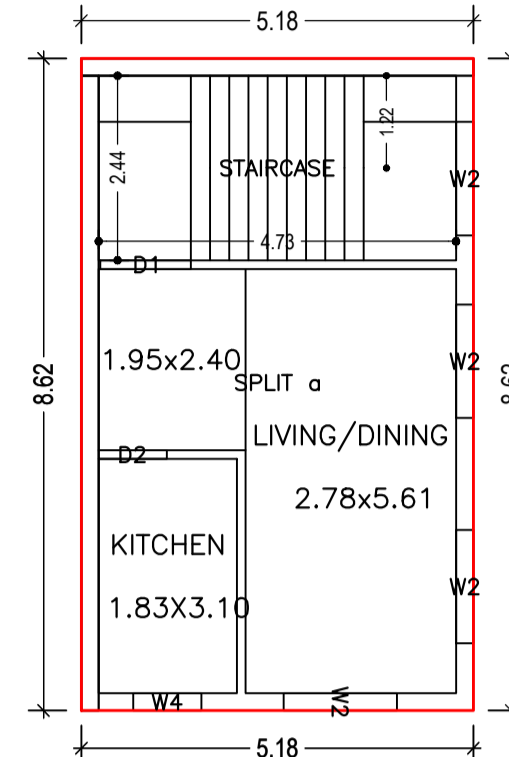

FIRST FLOOR PLAN
(Proposed)
(SCALE 1:100)

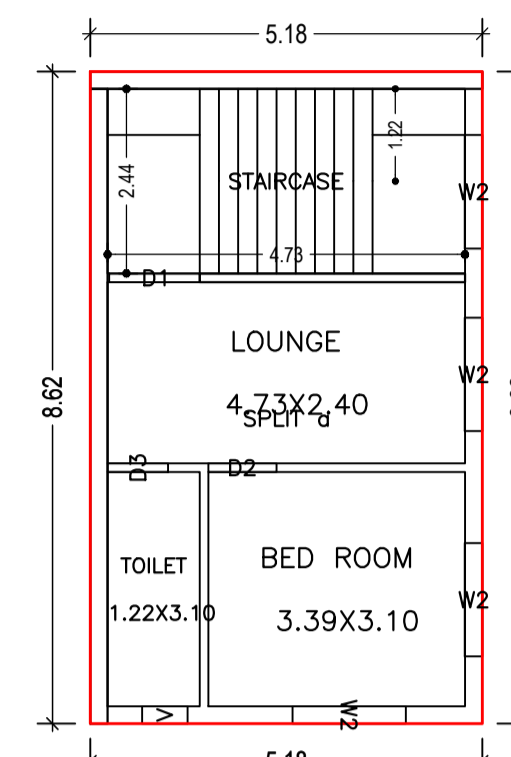

SECOND FLOOR PLAN
(Proposed)
(SCALE 1:100)

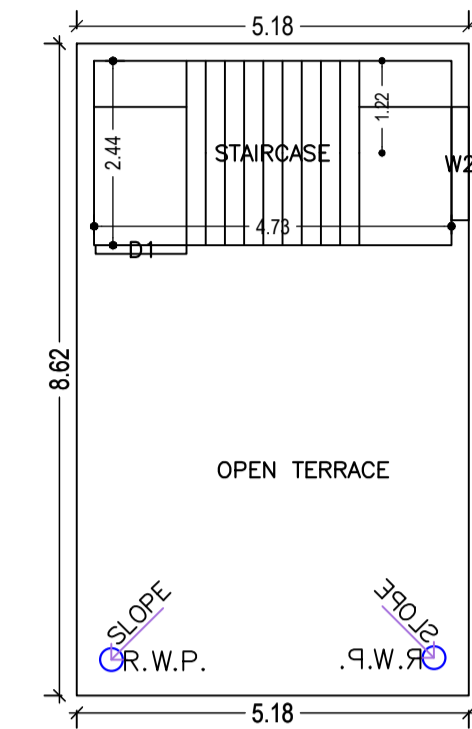

TERRACE FLOOR PLAN
(SCALE 1:100)

COLOR INDEX	
PLOT BOUNDARY	Black
ABUTTING ROAD	Red
PROPOSED CONSTRUCTION	Green
COMMON PLOT	Yellow
ROAD WIDENING AREA	Orange
EXISTING (To be retained)	Blue
EXISTING (To be demolished)	Light Blue

Building USE/SUBUSE Details

Building Name	Building Use	Building SubUse	Building Structure
A (GENDA LAL SHAH AND OTHERS)	Residential	Row House	Non-Highrise

Buildingwise Floor FAR Details

Floor Name	Building Name		Total	
	A (GENDA LAL SHAH AND OTHERS)		Total Proposed Built Up Area (Sq.mt.)	Total FAR Area (Sq.mt.)
Parking Floor	44.72	11.54	44.72	11.54
First Floor	44.71	44.71	44.71	44.71
Second Floor	44.71	44.71	44.71	44.71
Terrace Floor	0.00	0.00	0.00	0.00
Total :	134.14	100.96	134.14	100.96

FAR & Tenement Details (Table 4c-1)

Building	No. of Same Bldg	Total Built Up Area (Sq.mt.)	Deductions (Area in Sq.mt.)	Proposed FAR Area (Sq.mt.)		Total FAR Area (Sq.mt.)	Total Consumed Additional FAR Area (Sq.mt.)	Trmt (No.)
				Parking	Resi.			
A (GENDA LAL SHAH AND OTHERS)	1	134.14	33.18	89.42	11.54	100.96	100.96	01
Grand Total :	1	134.14	33.18	89.42	11.54	100.96	100.96	01

AREA STATEMENT		VERSION NO.: 1.0.65
JAMSHEDPUR NAC		VERSION DATE: 16/10/2020
PROJECT DETAIL:		
Region: JHARKHAND URBAN	Plot Use: Residential	
LOCAL BODIES		
District: EAST SINGHBHUM	Plot SubUse: Row House	
Authority: JAMSHEDPUR NAC	PlotNearbyReligiousStructure: NA	
Inward No: JNAC/BP/0002/W11/2023	Plot/SubPlot No: 110	
Application Type: General Proposal	North: Plot No. - 109	
Project Type: Building Permission	South: Plot No. - 111	
Nature of Development: New	East: Road Width - 5.0 ALLEY	
Location of Development Area: Old Area	West: Road Width - 9.0 ROAD	
AREA DETAILS:		
AREA OF PLOT (Minimum)	(A)	SQ.MT. 74.11
NET AREA OF PLOT(Gross Plot Area - Deduction from Gross Plot area)	(A-Deductions)	74.11
Deduction for Balance Plot Area(from Gross Plot Area)		
Common Plot		6.42
Total		6.42
BALANCE AREA OF PLOT(Net Plot Area - Recreational/Amenity space)	(A-Deductions)	67.69
PLOT AREA FOR COVERAGE(Net Plot Area)	(A-Deductions)	74.11
Plot Area for FAR (Net Plot Area + RoadWidening Area)	(A-Deductions)	74.11
COVERAGE CHECK		
Permissible Coverage area (70.00 %)		51.88
Proposed Coverage Area (60.33 %)		44.71
Total Prop. Coverage Area (60.33 %)		44.71
Balance coverage area (9.67 %)		7.17
FAR CHECK		
Perm. FAR Area (2.500)		185.27
Total Perm. FAR area		185.27
Residential FAR		89.42
Proposed FAR Area		100.96
Total Proposed FAR Area		100.96
Consumed FAR (Factor)		1.36
Balance FAR Area		84.31
BUILT UP AREA CHECK		
Total Proposed BuiltUp Area		134.14
ARCHITECT (Regd)	SHREYASHI PAUL	
ENGINEER (Regd)		
SUPERVISOR (Regd)		
OWNER (Regd)	GENDA LAL SHAH AND OTHERS	
DEVELOPMENT AUTHORITY		LOCAL BODY

LTP NAME AND SIGNATURE	STRUCTURAL ENG'S NAME AND SIGNATURE	BUILDER NAME AND SIGNATURE	DIGITAL SIGNATURE
SHREYASHI PAUL JNAC/DFTMN/0009/2016			

Proposal Basic Information	
Proposal File No.	JNAC/BP/0002/W11/2023
Owner Name	GENDA LAL SHAH AND OTHERS
Khata No	NIL
Plot No	110
Village Name	Sitaramdera
Use	Residential
SubUse	Row House

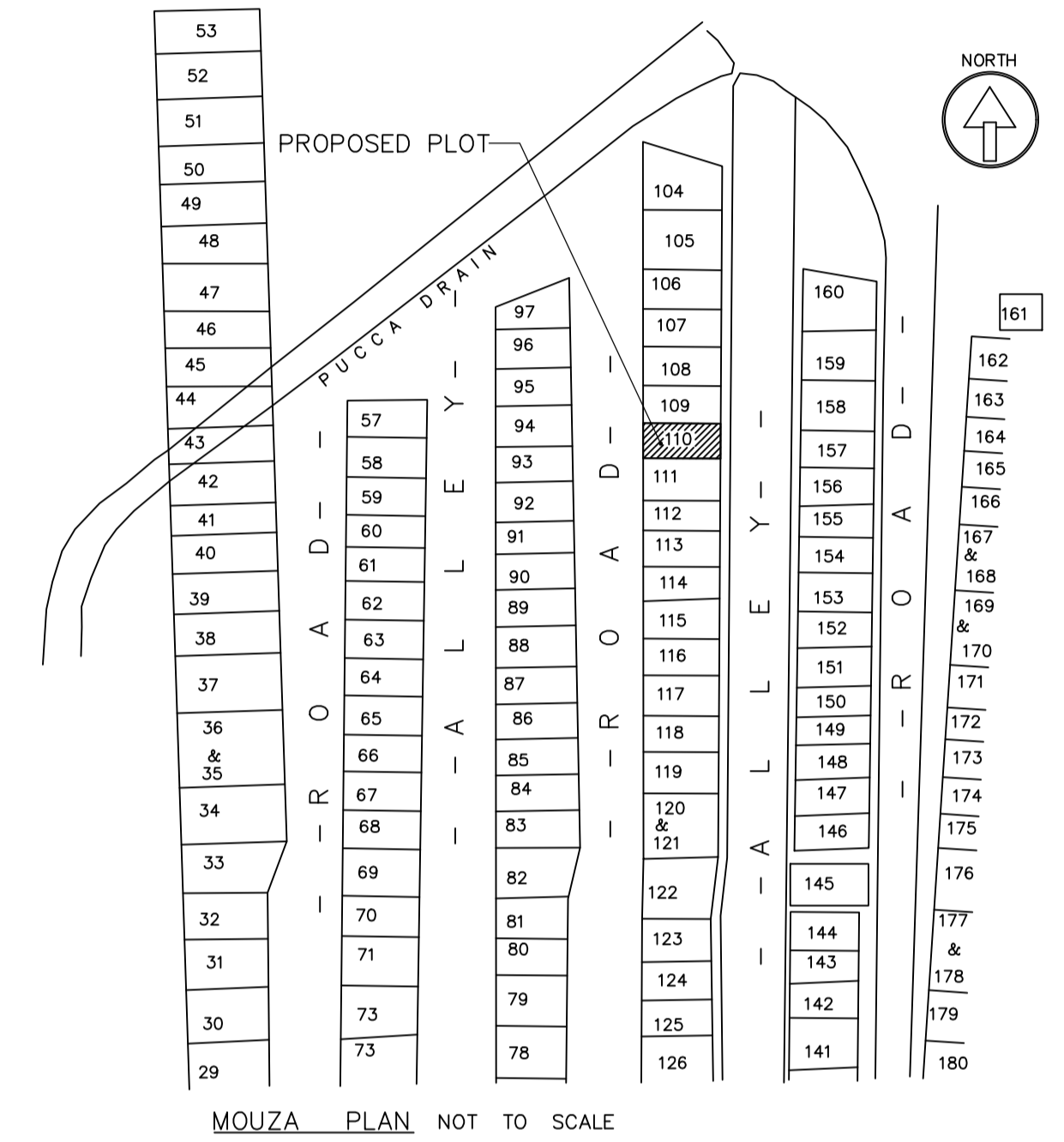
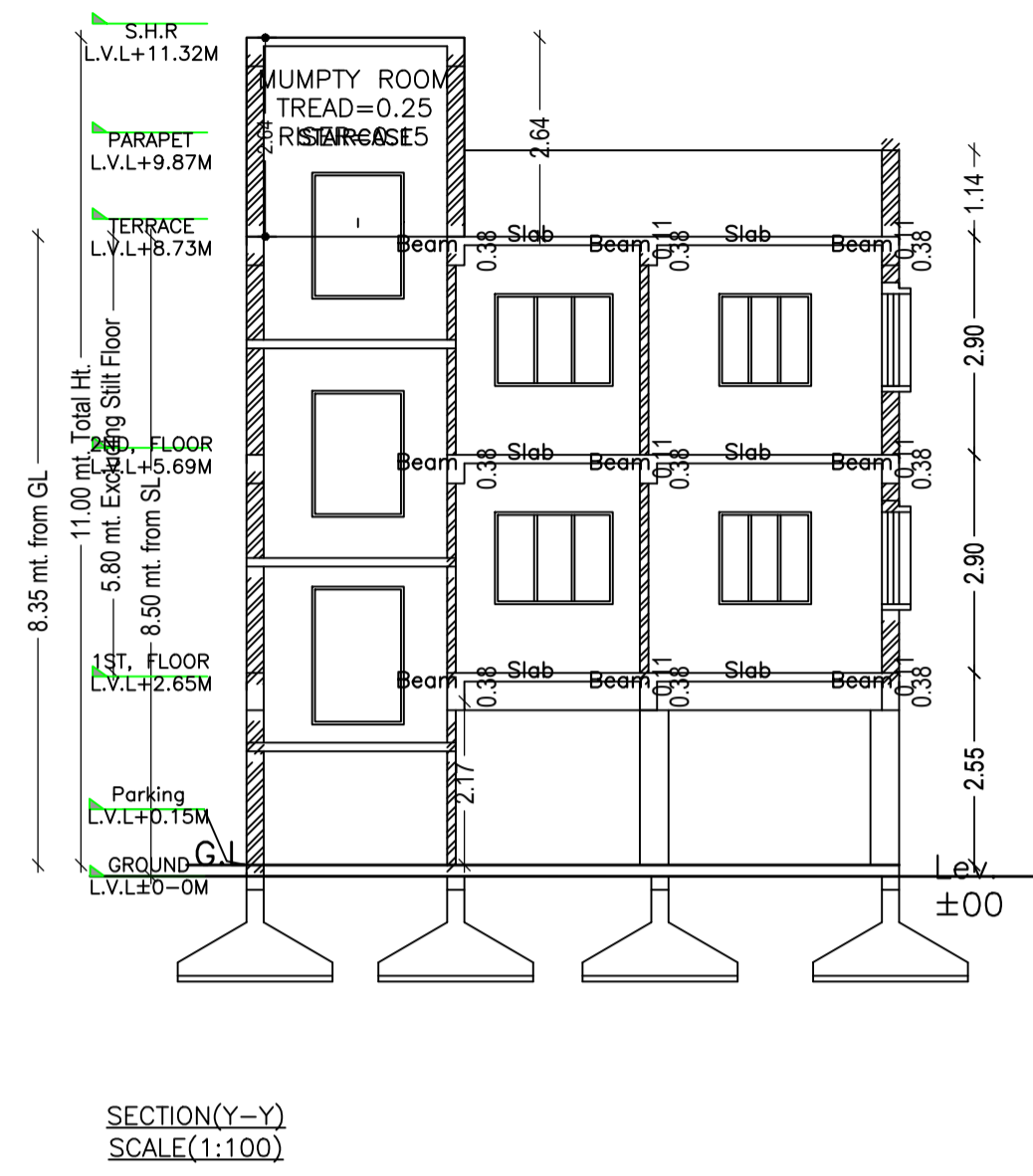
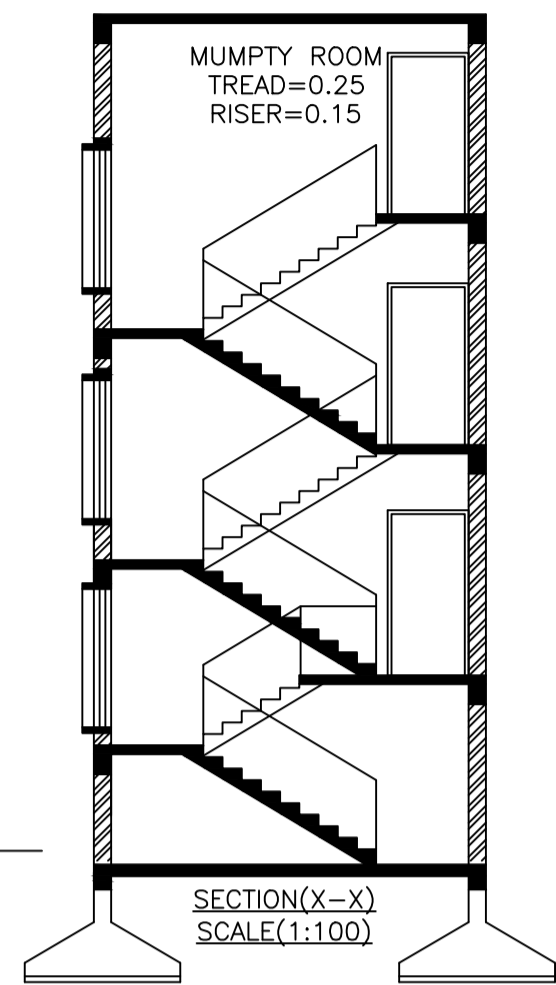
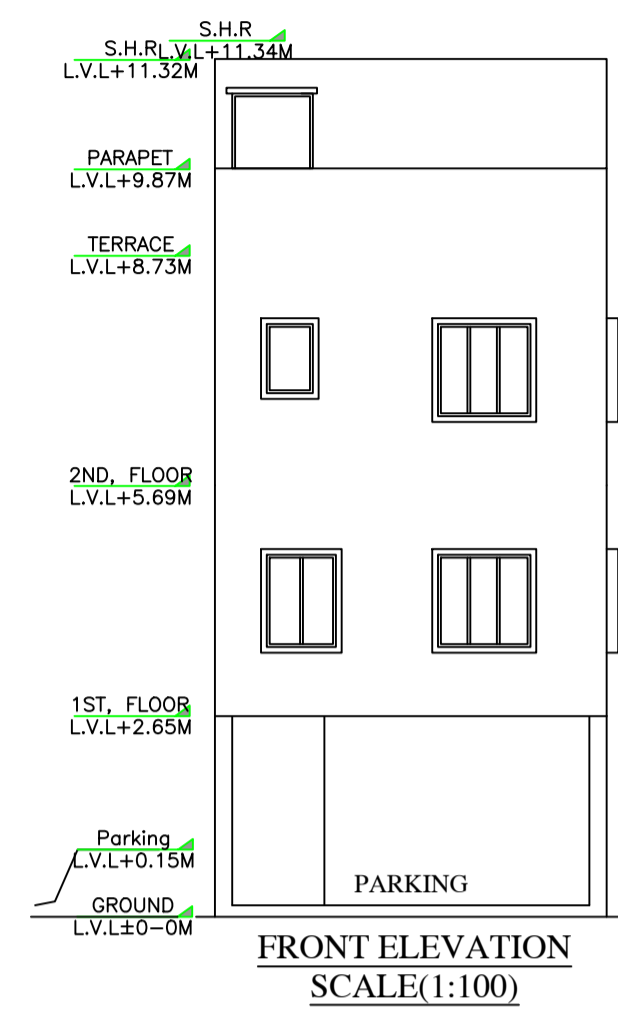
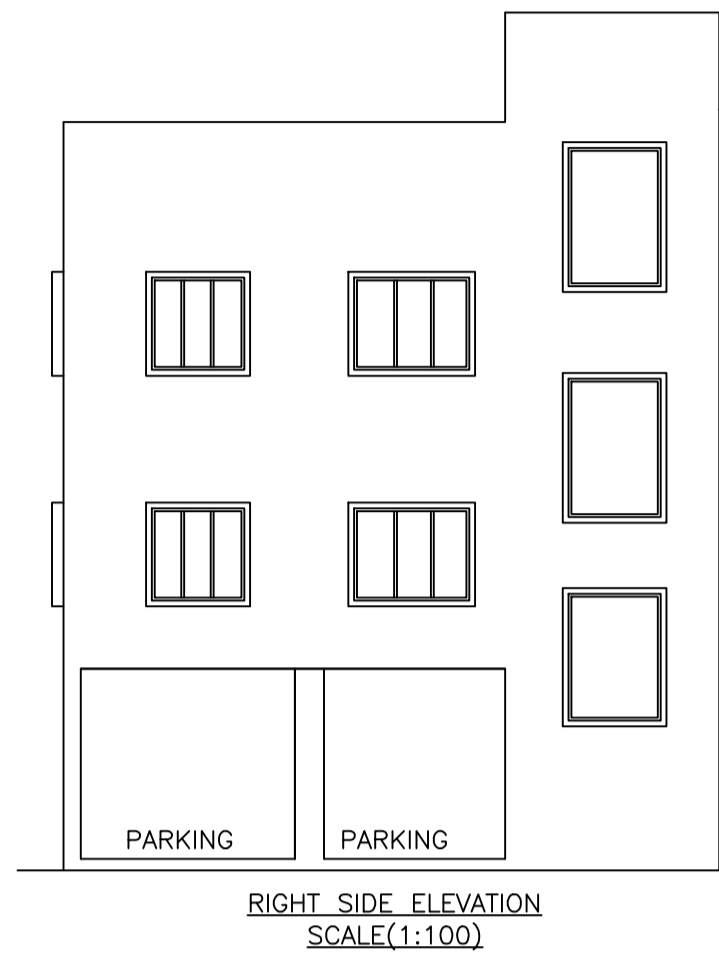

SCHEDULE OF DOOR:

BUILDING NAME	NAME	LENGTH	HEIGHT	NOS
A (GENDA LAL SHAH AND OTHERS)	D3	0.80	2.10	01
A (GENDA LAL SHAH AND OTHERS)	D2	0.90	2.10	02
A (GENDA LAL SHAH AND OTHERS)	D1	1.20	2.10	02

SCHEDULE OF WINDOW/VENTILATION:

BUILDING NAME	NAME	LENGTH	HEIGHT	NOS
A (GENDA LAL SHAH AND OTHERS)	V	0.60	0.60	01
A (GENDA LAL SHAH AND OTHERS)	W4	0.90	1.20	01
A (GENDA LAL SHAH AND OTHERS)	W2	1.50	1.20	10

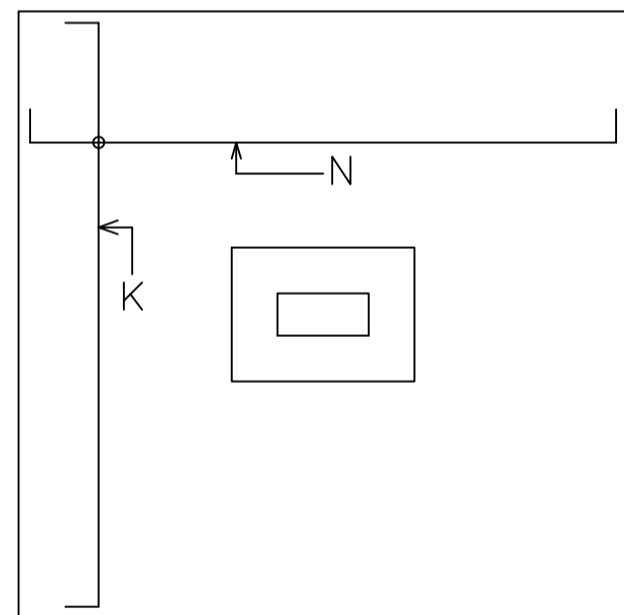

PLAN OF FOOTING

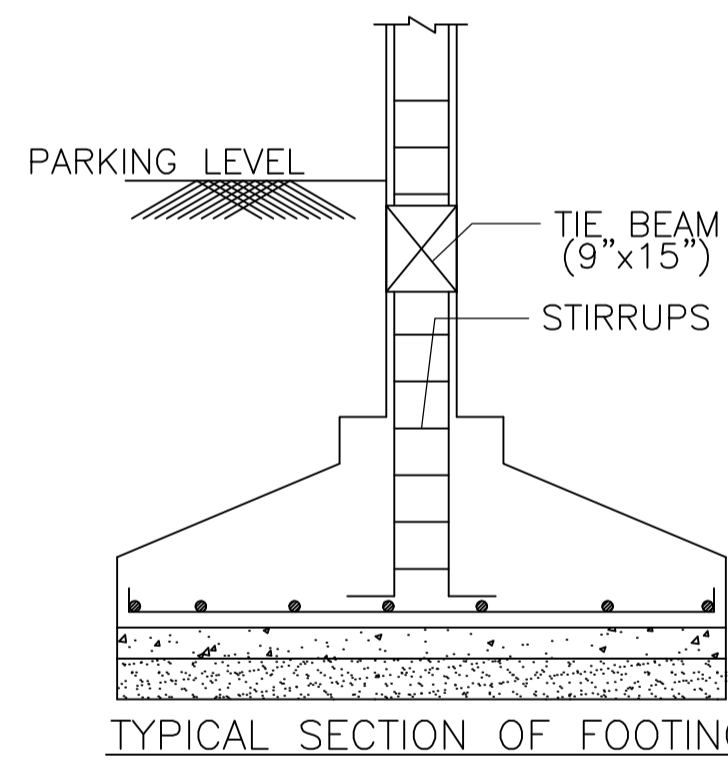

TYPICAL SECTION OF FOOTING

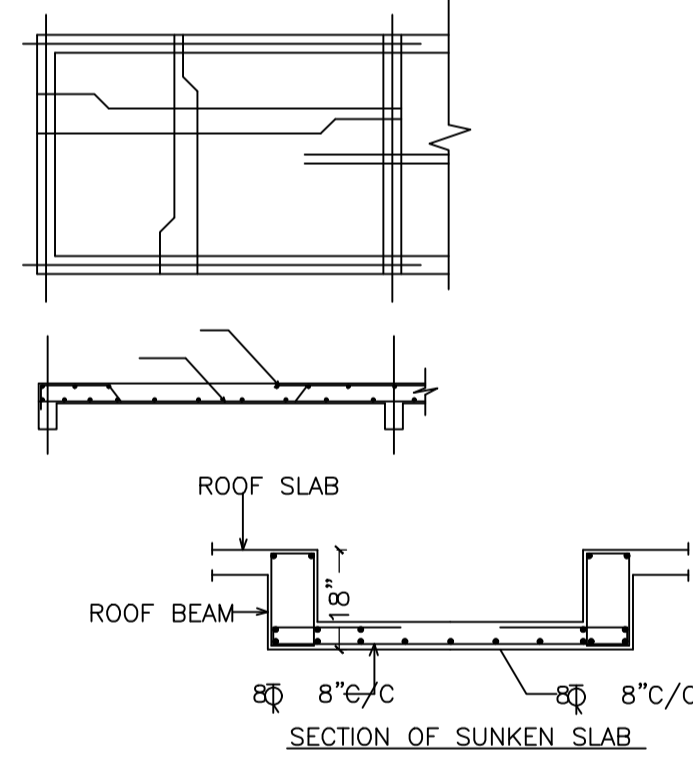

SECTION OF SUNKEN SLAB

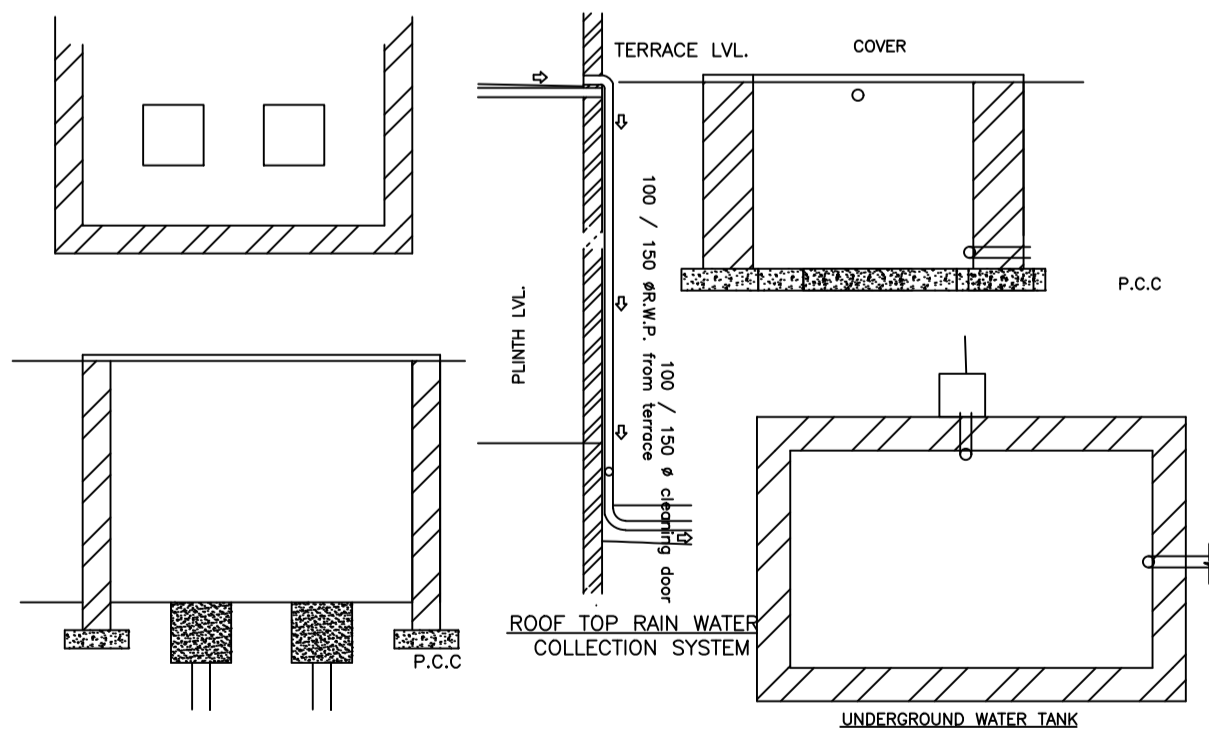

UnitBUA Table for Building :A (GENDA LAL SHAH AND OTHERS)

FLOOR PLAN	Name	UnitBUA Type	UnitBUA Area	Carpet Area	No. of Rooms	No. of Tenement
FIRST FLOOR PLAN	SPLIT a		89.42	82.81	2	1
SECOND FLOOR PLAN	SPLIT a	FLAT	0.00	0.00	3	0
			89.42	82.81	5	1

Building :A (GENDA LAL SHAH AND OTHERS)

Floor Name	Total Built Up Area (Sq.mt.)	Deductions (Area in Sq.mt.)	Proposed FAR Area (Sq.mt.)	Add Area In FAR (Sq.mt.)	Total FAR Area (Sq.mt.)	Total Consumed Additional FAR Area (Sq.mt.)	Tnmt (No.)
Parking Floor	44.72	33.18	0.00	11.54	11.54	11.54	00
First Floor	44.71	0.00	44.71	0.00	44.71	44.71	01
Second Floor	44.71	0.00	44.71	0.00	44.71	44.71	00
Terrace Floor	0.00	0.00	0.00	0.00	0.00	0.00	00
Total :	134.14	33.18	89.42	11.54	100.96	100.96	01
Total Number of Same Buildings :	1						
Total :	134.14	33.18	89.42	11.54	100.96	100.96	01

LTP NAME AND SIGNATURE	STRUCTURAL ENG'S NAME AND SIGNATURE	BUILDER NAME AND SIGNATURE	DIGITAL SIGNATURE
SHREYASHI PAUL JNAC/DFTMN/0009/2016			