

Proposal Basic Information

Proposal File No.	JNAC/BP/0050/W3/2023
Owner Name	SMT. RASHMI NAGI AND SMT RAJWANT KAUR
Khata No	NIL
Plot No	H.NO 77
Village Name	Bisthupur
Use	Residential
SubUse	Row House

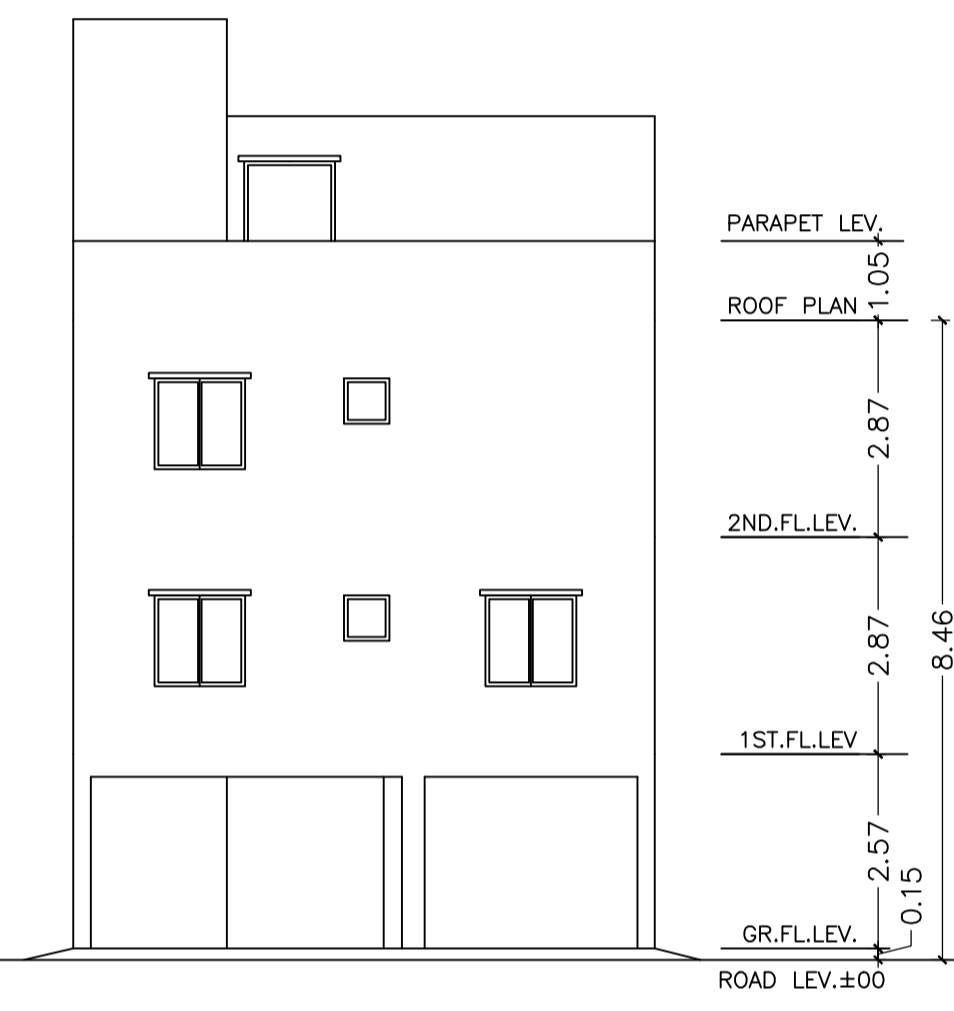
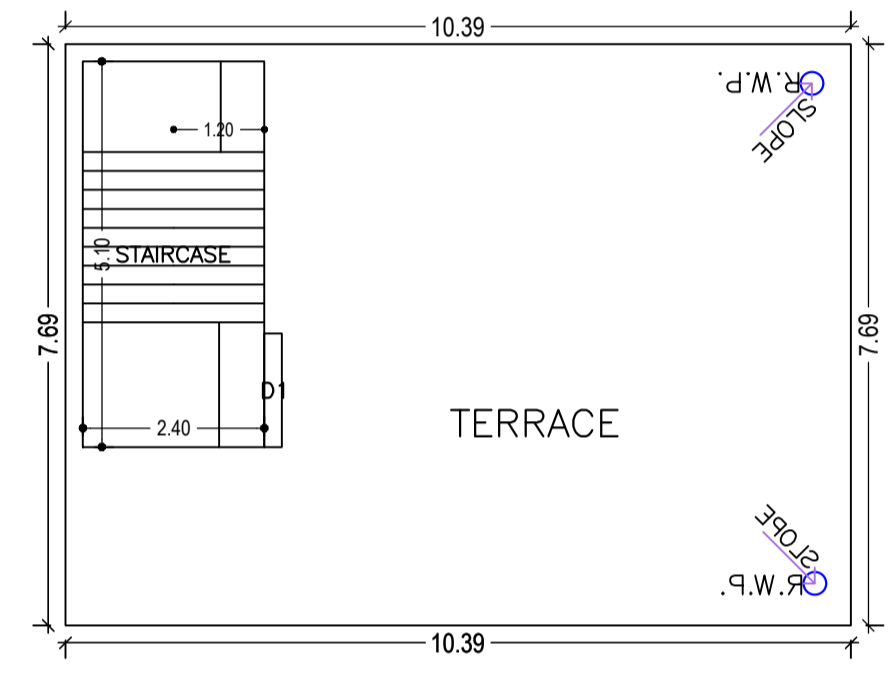
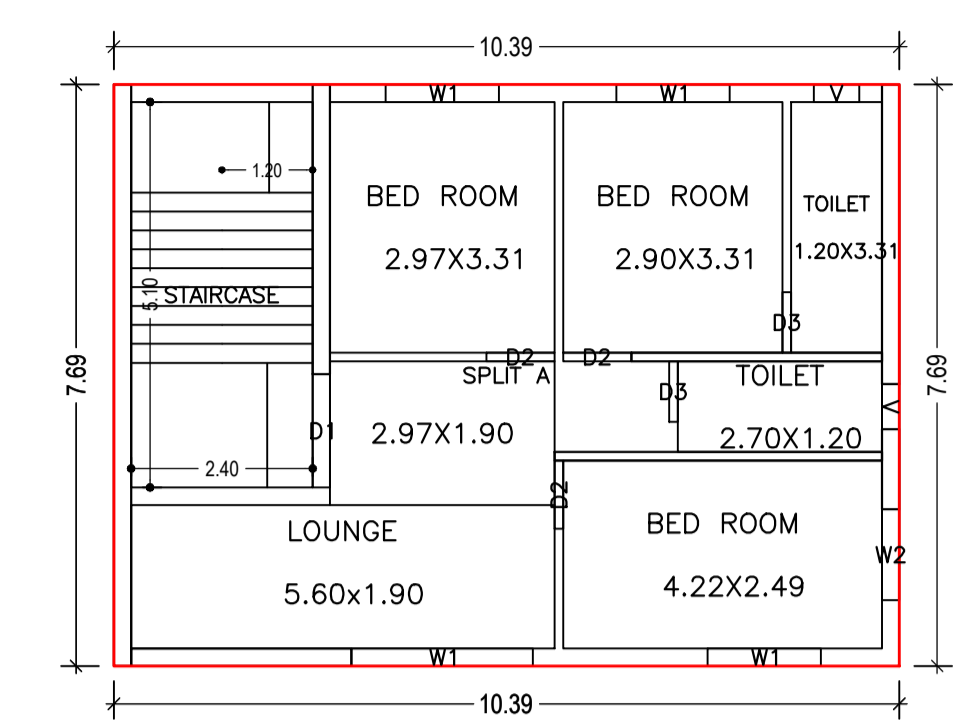
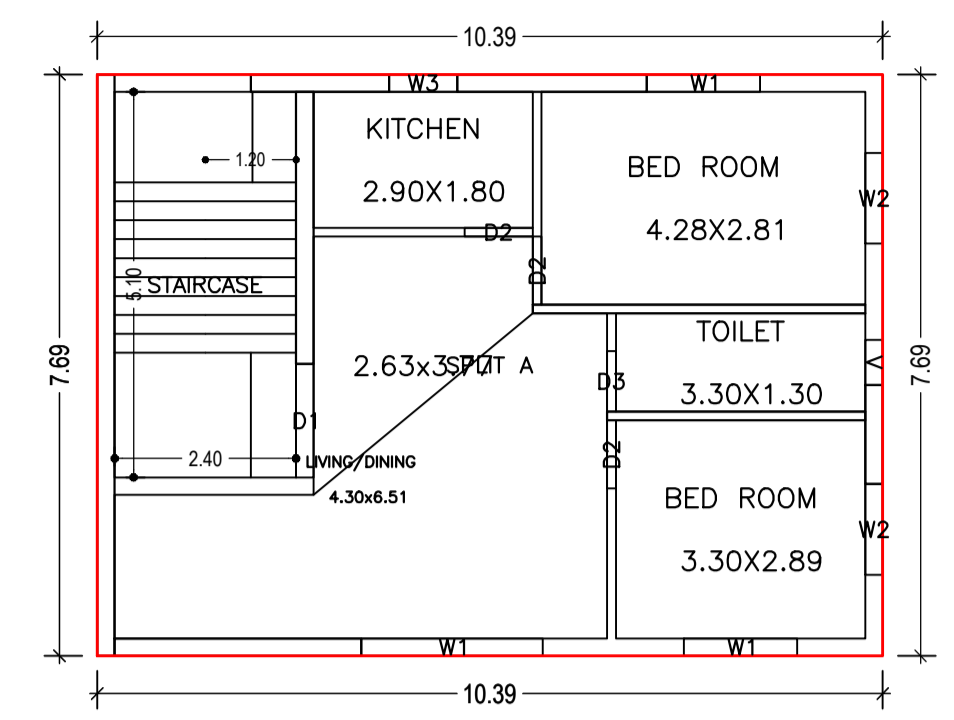
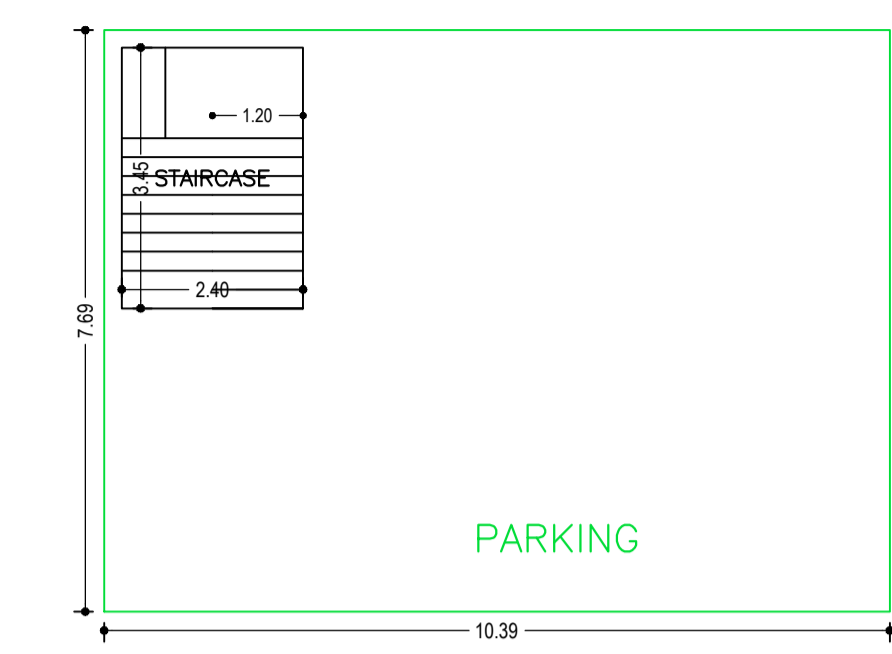
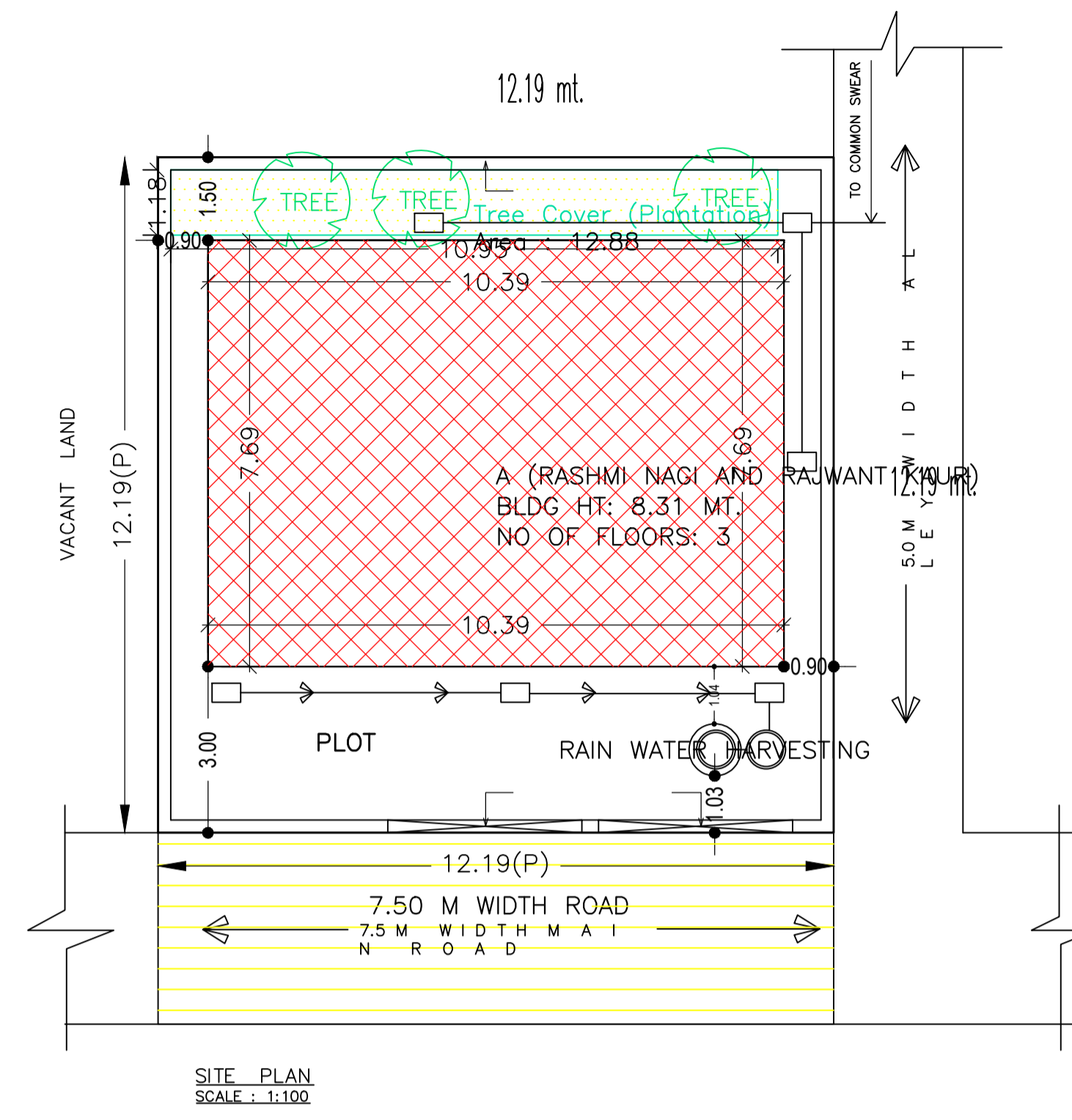

Building :A (RASHMI NAGI AND RAJWANT KAUR)

Floor Name	Total Built Up Area (Sq.mt.)	Deductions (Area in Sq.mt.)	Proposed FAR Area (Sq.mt.)	Add Area In FAR (Sq.mt.)	Total FAR Area (Sq.mt.)	Total Consumed Additional FAR Area (Sq.mt.)	Trmt (No.)
Parking Floor	79.90	71.62	0.00	8.28	8.28	8.28	00
First Floor	79.90	0.00	79.90	0.00	79.90	79.90	01
Second Floor	79.90	0.00	79.90	0.00	79.90	79.90	00
Terrace Floor	0.00	0.00	0.00	0.00	0.00	0.00	00
Total :	239.70	71.62	159.80	8.28	168.08	168.08	01

SCHEDULE OF DOOR:

BUILDING NAME	NAME	LENGTH	HEIGHT	NOS
A (RASHMI NAGI AND RAJWANT KAUR)	D3	0.80	2.10	03
A (RASHMI NAGI AND RAJWANT KAUR)	D2	0.90	2.10	06

SCHEDULE OF WINDOW/VENTILATION:

BUILDING NAME	NAME	LENGTH	HEIGHT	NOS
A (RASHMI NAGI AND RAJWANT KAUR)	V	0.60	0.60	03
A (RASHMI NAGI AND RAJWANT KAUR)	W3	0.90	1.20	01
A (RASHMI NAGI AND RAJWANT KAUR)	W2	1.20	1.20	03
A (RASHMI NAGI AND RAJWANT KAUR)	W1	1.50	1.20	05
A (RASHMI NAGI AND RAJWANT KAUR)	D1	1.50	1.20	03
A (RASHMI NAGI AND RAJWANT KAUR)	W1	2.40	1.20	02

UnitBUA Table for Building :A (RASHMI NAGI AND RAJWANT KAUR)

FLOOR	Name	UnitBUA Type	UnitBUA Area	Carpet Area	No. of Rooms	No. of Tenement
FIRST FLOOR PLAN	SPLIT A	FLAT	159.80	148.90	5	1
SECOND FLOOR PLAN	SPLIT A	FLAT	0.00	0.00	6	0
Total:	-	-	159.80	148.90	11	1

AREA STATEMENT	VERSION NO. : 1.0.66	SQ.MT.
JAMSHEDPUR NAC	VERSION DATE: 16/10/2020	
PROJECT DETAIL:		
Region: JHARKHAND URBAN LOCAL BODIES	Plot Use: Residential	
District: EAST SINGHBHUM	Plot SubUse: Row House	
Authority: JAMSHEDPUR NAC	Plot/Nearby/Religious/Structure: NA	
Inward No. :JNAC/BP/0050/W3/2023	Plot/SubPlot No: H NO 77	
Application Type: General Proposal	North: Road Width - 7.50 M	
Project Type: Building Permission	South: Road Width - 4.50M	
Nature of Development: New	East: Plot No. - 76 A	
Location of Development Area: Old Area	West: Plot No. - 78	
AREA DETAILS:		
AREA OF PLOT (Minimum)	(A)	148.60
NET AREA OF PLOT(Gross Plot Area - Deduction from Gross Plot area)	(A-Deductions)	148.60
Deduction for Balance Plot Area(from Gross Plot Area)		
Common Plot		12.88
Total		12.88
BALANCE AREA OF PLOT(Net Plot Area - Recreational/Amenity space)	(A-Deductions)	135.71
PLOT AREA FOR COVERAGE(Net Plot Area)	(A-Deductions)	148.60
Plot Area for FAR (Net Plot Area + RoadWidening Area)	(A-Deductions)	148.60
COVERAGE CHECK		
Permissible Coverage area (70.00 %)		104.02
Proposed Coverage Area (53.77 %)		79.90
Total Prop. Coverage Area (53.77 %)		79.90
Balance coverage area (16.23 %)		24.12
FAR CHECK		
Perm. FAR Area (2.500)		371.50
Total Perm. FAR area		371.50
Residential FAR		159.80
Proposed FAR Area		168.08
Total Proposed FAR Area		168.08
Consumed FAR (Factor)		1.13
Balance FAR Area		203.42
BUILT UP AREA CHECK		
Total Proposed BuiltUp Area		239.70
ARCHITECT (Regd)	SHREYASHI PAUL	
ENGINEER (Regd)		
SUPERVISOR (Regd)		
OWNER (Regd)	SMT. RASHMI NAGI AND SMT RAJWANT KAUR	
DEVELOPMENT AUTHORITY	LOCAL BODY	

BUILDING NAME	NAME	LENGTH	HEIGHT	NOS
A (RASHMI NAGI AND RAJWANT KAUR)	V	0.60	0.60	03
A (RASHMI NAGI AND RAJWANT KAUR)	W3	0.90	1.20	01
A (RASHMI NAGI AND RAJWANT KAUR)	W2	1.20	1.20	03
A (RASHMI NAGI AND RAJWANT KAUR)	W1	1.50	1.20	05
A (RASHMI NAGI AND RAJWANT KAUR)	D1	1.50	1.20	03
A (RASHMI NAGI AND RAJWANT KAUR)	W1	2.40	1.20	02

FLOOR	Name	UnitBUA Type	UnitBUA Area	Carpet Area	No. of Rooms	No. of Tenement
FIRST FLOOR PLAN	SPLIT A	FLAT	159.80	148.90	5	1
SECOND FLOOR PLAN	SPLIT A	FLAT	0.00	0.00	6	0
Total:	-	-	159.80	148.90	11	1

Building Name	Building Use	Building SubUse	Building Structure
A (RASHMI NAGI AND RAJWANT KAUR)	Residential	Row House	Non-Highrise

Building	No. of Same Bldg	Total Built Up Area (Sq.mt.)	Deductions (Area in Sq.mt.)	Proposed FAR Area (Sq.mt.)	Add Area In FAR (Sq.mt.)	Total FAR Area (Sq.mt.)	Total Consumed Additional FAR Area (Sq.mt.)	Trmt (No.)
A (RASHMI NAGI AND RAJWANT KAUR)	1	239.70	71.62	159.80	8.28	168.08	168.08	01
Grand Total :	1	239.70	71.62	159.80	8.28	168.08	168.08	01

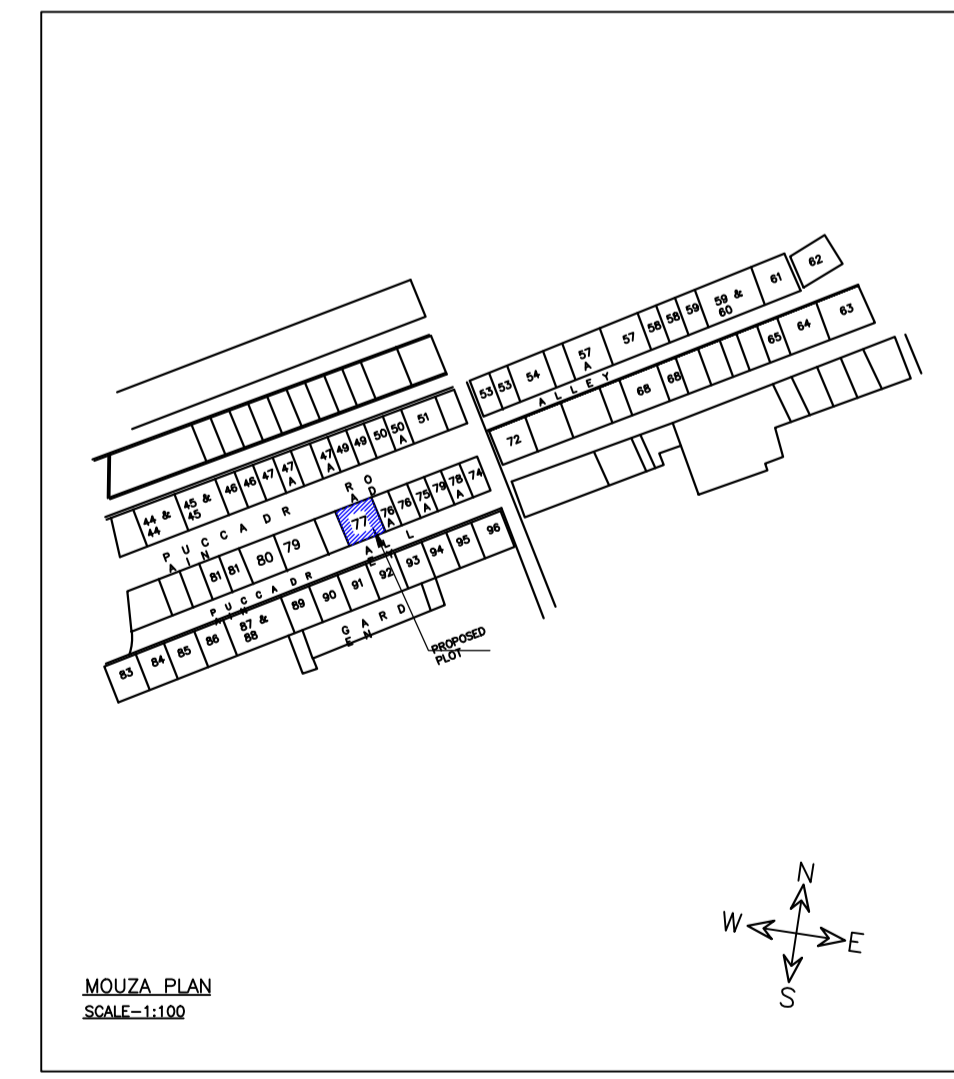
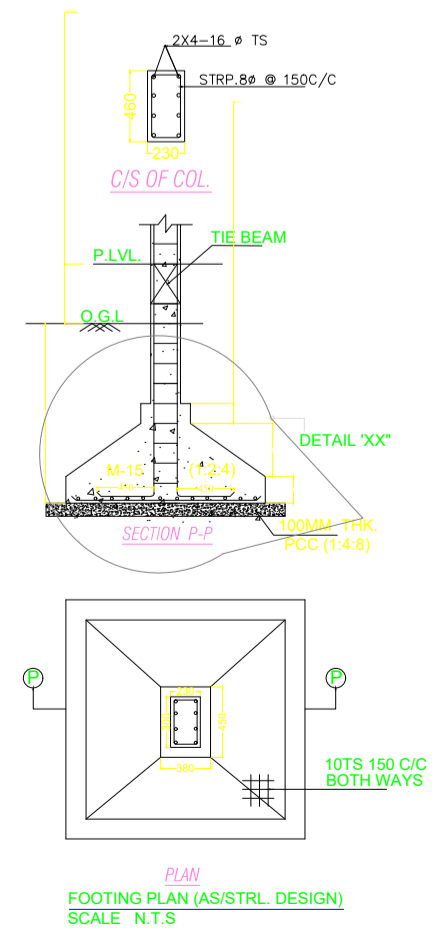
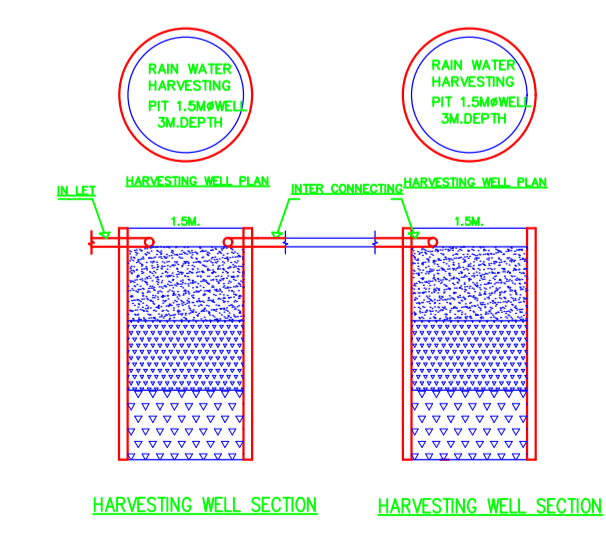
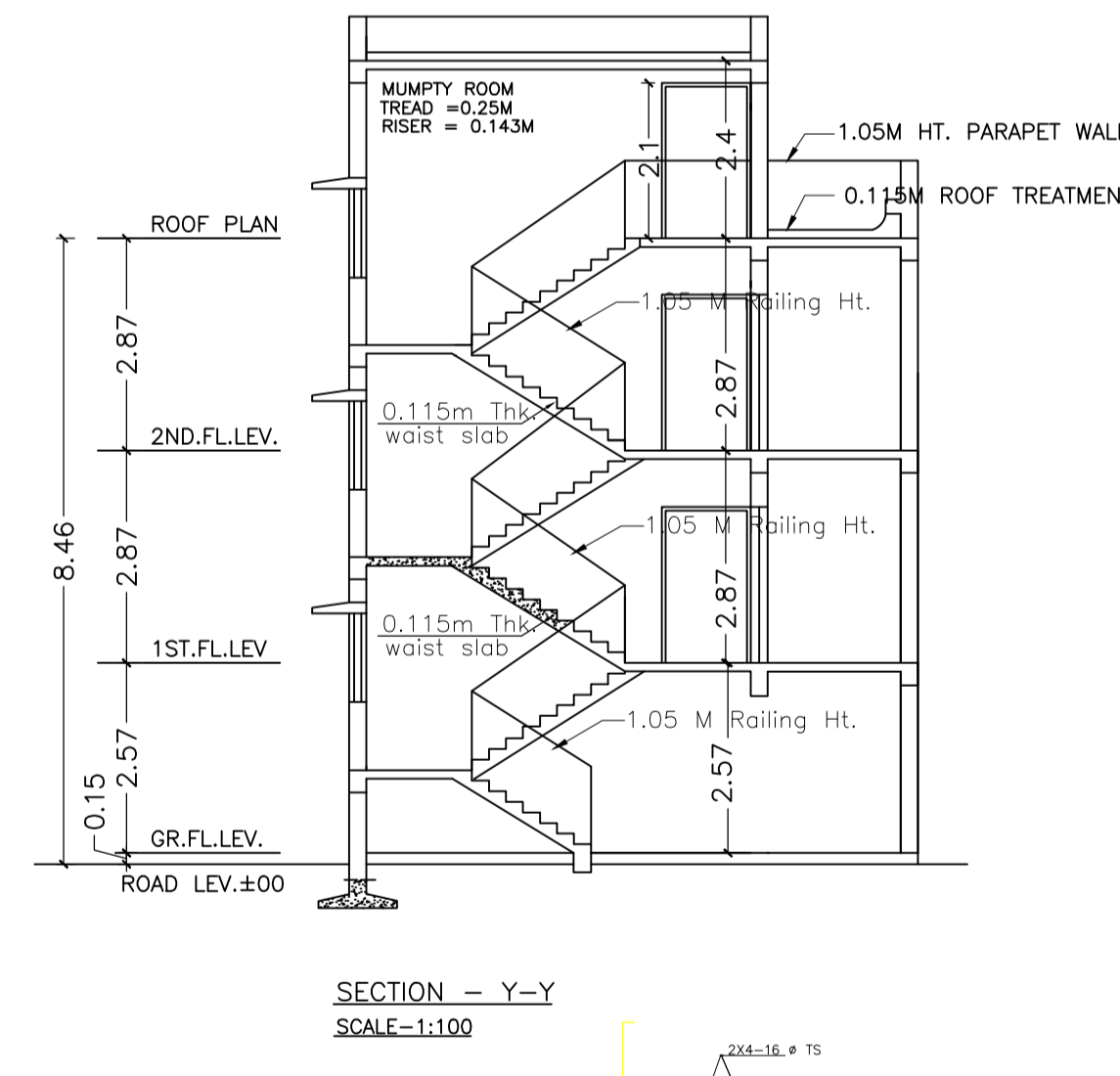
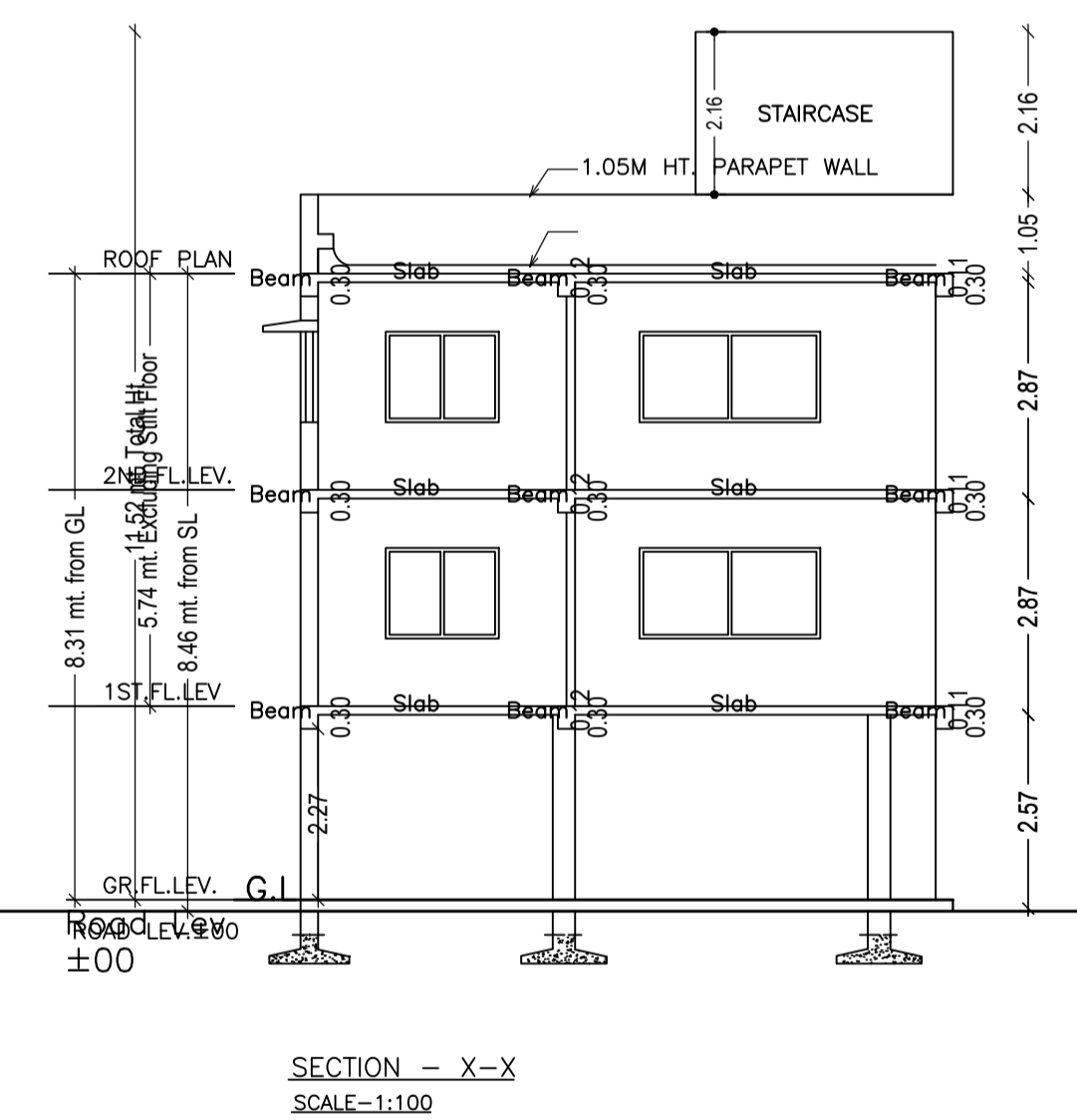

LTP NAME AND SIGNATURE	STRUCTURAL ENG'S NAME AND SIGNATURE	BUILDER NAME AND SIGNATURE	DIGITAL SIGNATURE
SHREYASHI PAUL JNAC/DFTMN/009/2016			