

Project Title :SRI. AZAZ AHMAD & OTHERS

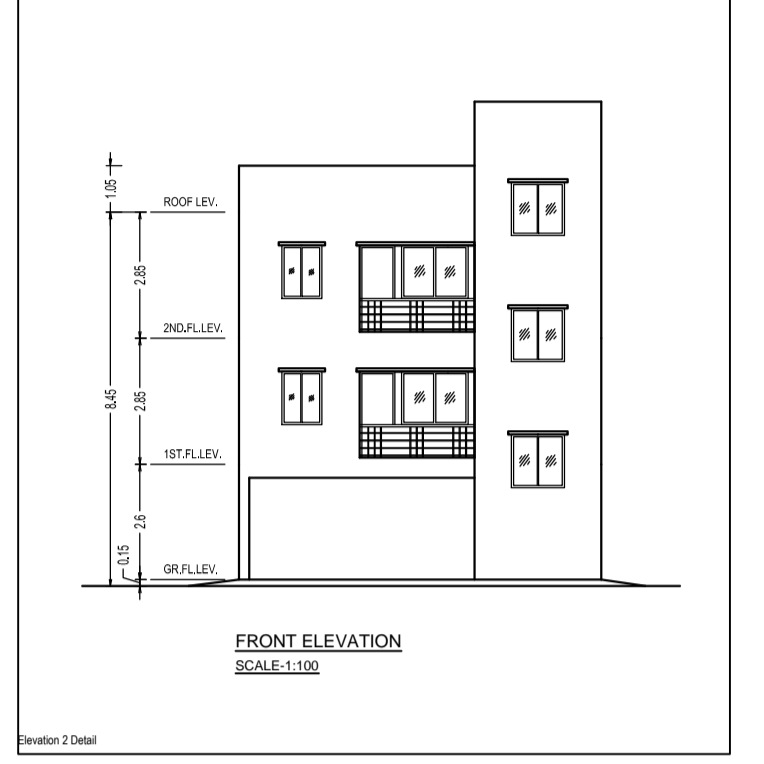
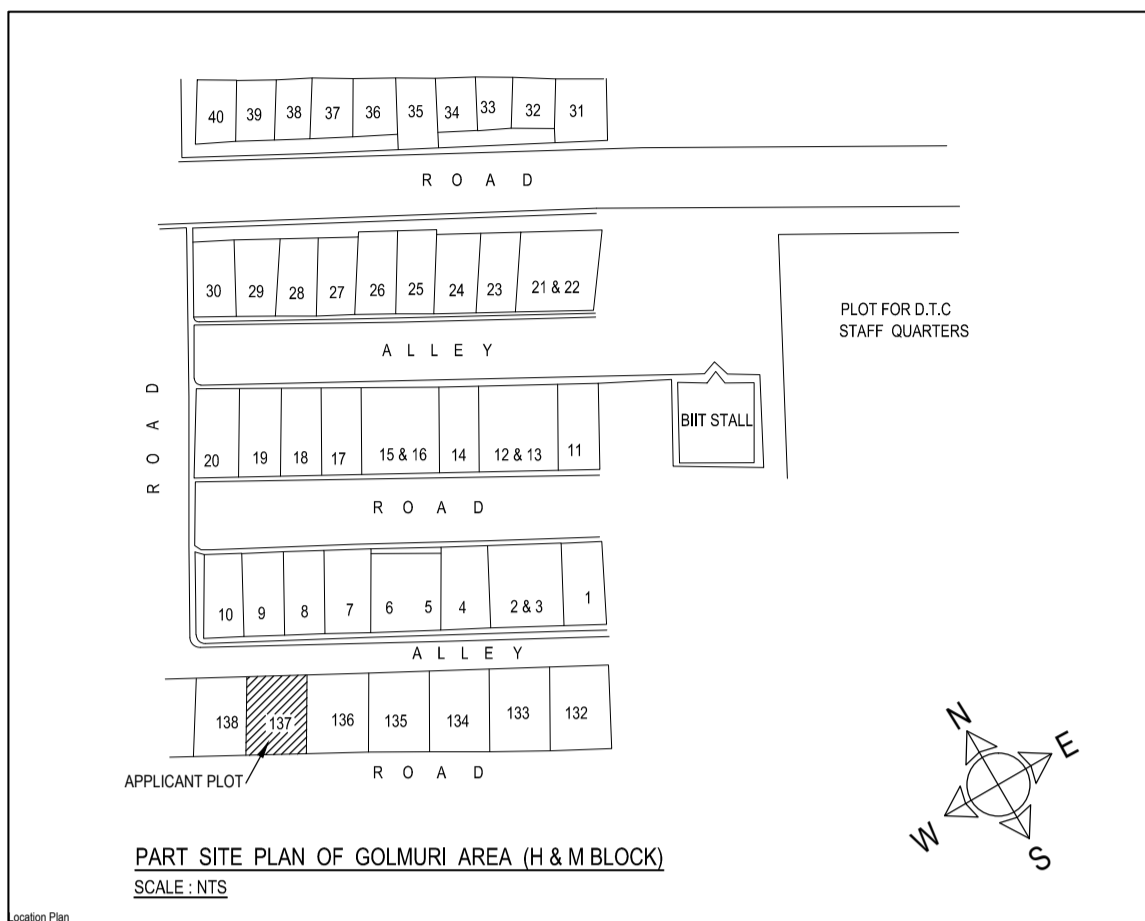

**NOTE**  
1. FOUNDATION & R.C.C. AS PER STRUCTURAL ENGS. SPECIFICATION  
2. ALL DIMENSIONS IN METERS  
3. DRAWING NOT TO BE SCALED

AREA OF FLOOR			
AREA OF PLOT (Minimum)	(A)	322.87	111.28
Net Plotted Area (Gross Plot Area)	(A-Deductions)		111.28
- Deductions from (Gross Plot Area)			
- Deductions for Balance Plot Area from (Gross Plot Area)			13.49
Net Area			97.77
Balance Plot Area (Net Plot Area)	(A-Deductions)		111.28
- Deductions from (Net Plot Area)			
- Deductions for Balance Plot Area from (Net Plot Area)			13.49
Final Area			97.77
Proposed Coverage Area (S 15 %)			14.67
Final Coverage Area (S 15 %)			70.31
Proposed Area of FAR			154.11
Final Area of FAR			154.11
Proposed Built-up Area			210.93
Actual Built-up Area			210.93
Approval Authority			LOCAL BODY

**COLOR INDEX**

FLIGHTING ROAD  
PROPOSED HOME COVERAGE AREA  
EXISTING (To be retained)  
EXISTING (To be demolished)

**Color Index:**

Flooring Type	Prop. No.	Prop. Area
Car Parking	2	25.00
Open Parking	1	28.92
Total Area	3	53.92

**MARGIN DETAIL:**

Building / Wing Name	Road Name	Front Margin	Rear Margin	Side Margin	Side2 Margin
A (RES. BLDG.)	S 15 % W.T. (BLDNG.)	2.00	1.50	0.02	0.02

**FAR & Terment Details (Table 4c-1)**

Building	No. of Same Buildings	Total Built-up Area (Sq.mt)	Deductions (Area in Sq.mt)	Proposed FAR Area (Sq.mt)	Add Area in FAR (Sq.mt)	Total FAR Area (Sq.mt)	Tract No.
A (RES. BLDG.)	1	210.93	3.00	140.92	13.49	154.11	01
Other Case	1	210.93	3.00	140.92	13.49	154.11	01

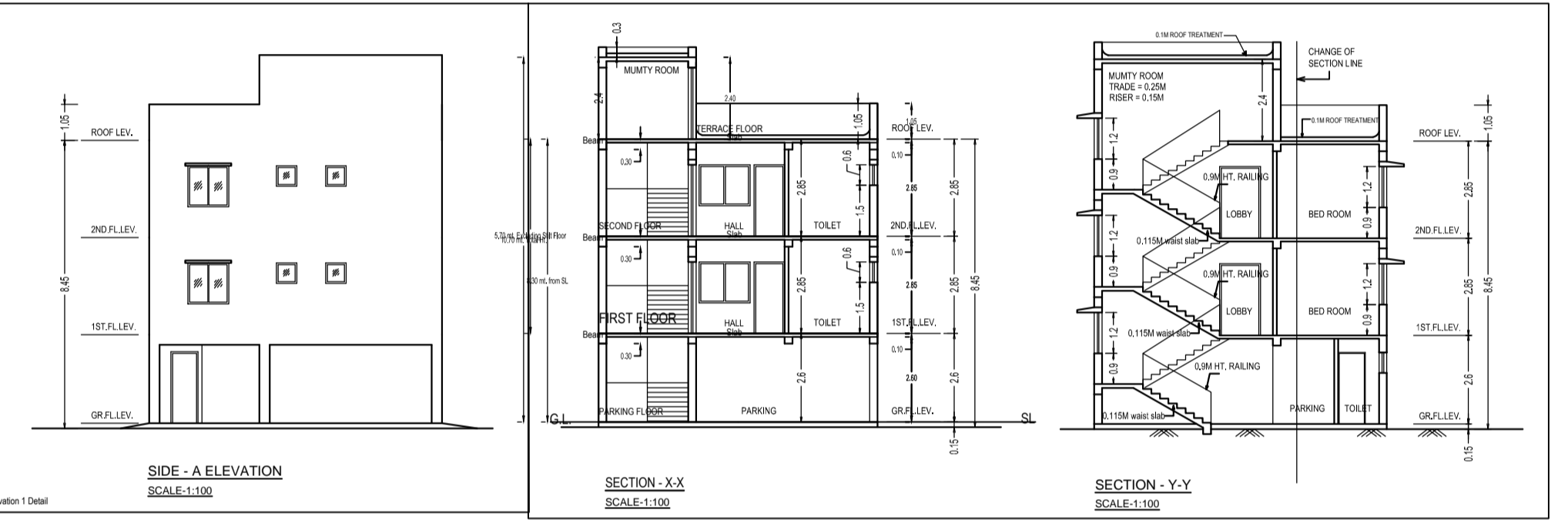
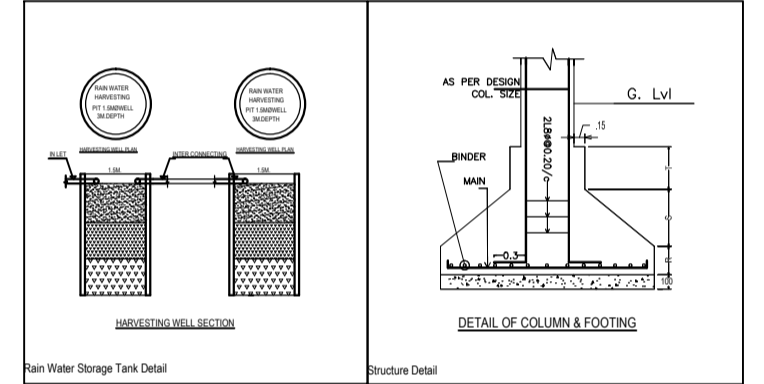

**APPROVED:-**

**SPL OFFICER, J.N.A.C., JAMSHEDPUR**

**OWNER / POAH**

**Signature of Applicant:-**

**GENERAL SPECIFICATION :-**

- FOUNDATION** - PLAN CONCRETE AS PER DESIGN
- R.C.C. COLUMN FOOTING & COLUMN** AS PER STRUCTURAL DESIGN
- R.C.C. COLUMN & BEAM** AS PER STR. DESIGN
- SUPER STRUCTURE** - 0.20M THK. EXT. WALL & 0.15M THK. PARTITION WALL IN CONCRETE
- FLOOR** - R.C.C. ROOF SLAB AS PER STRUCTURAL DESIGN
- FLOOR** - INSULATED CHERT BRIT. CERAMIC TILES LAPPED IN TOILET
- INTERNAL FINISH** - CONCRETE PLASTER WITH O.P.S. D.S.D.
- SANITARY** - VITRIFIED CHAM. CLAY SANITARY WARE. G.I. PIPE WATER SUPPLY.
- DOORS & WINDOW** - P.V.C. PROFILE FOR GARAGE DISPOSAL.
- ELECTRICAL** - COPPER WIRE WITH P.V.C. CONDUIT.

**PROPOSED RESIDENTIAL BUILDING PLAN OF SRI. AZAZ AHMAD & OTHERS HOLDING No. - 137, M/BLOCK GOLMURI AREA, DISTRICT - EAST SINGHBHUM, JHARKHAND TOWN - JAMSHEDPUR**

**L.K. SUMAN**

**SHEET No- 01 / 01**

**L.K. SUMAN**  
Office: 1. Second Floor  
Basant Talkies Complex,  
Sakchi, Jamshedpur

**Reg. No.- JNAC/ENG/006/2016**

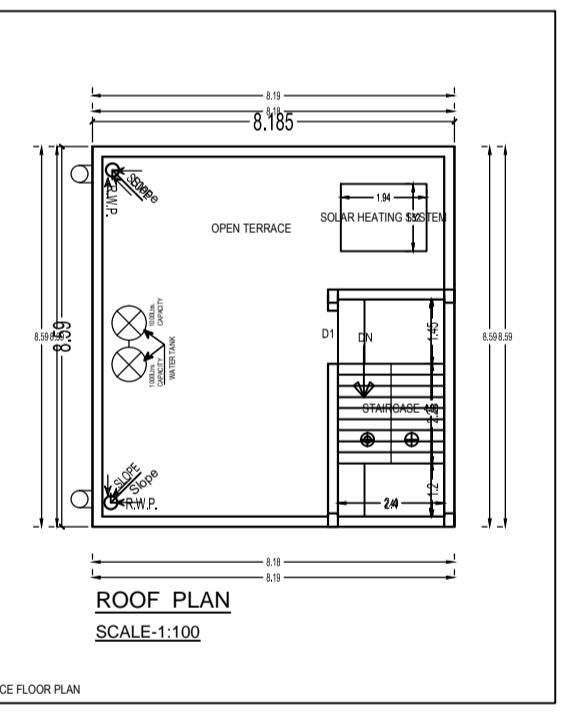
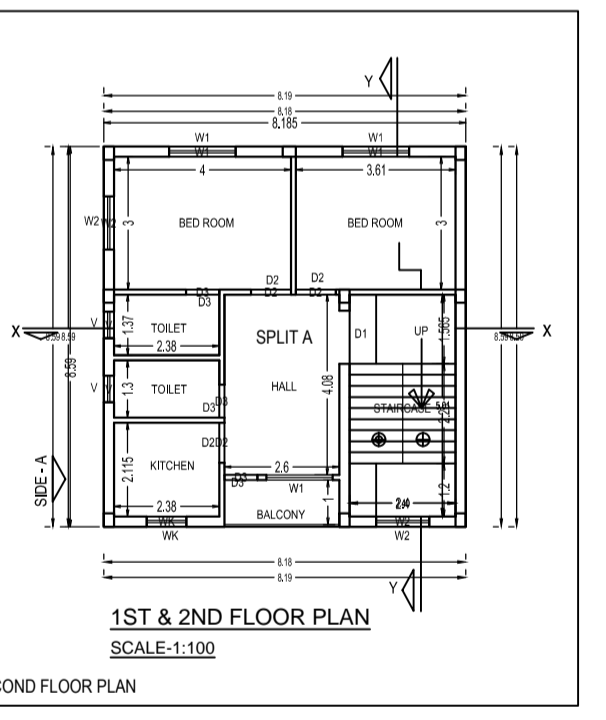
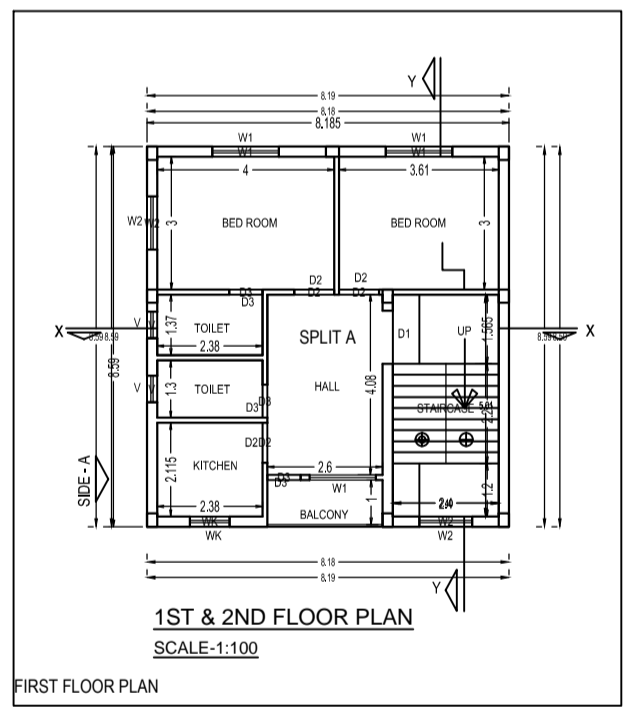
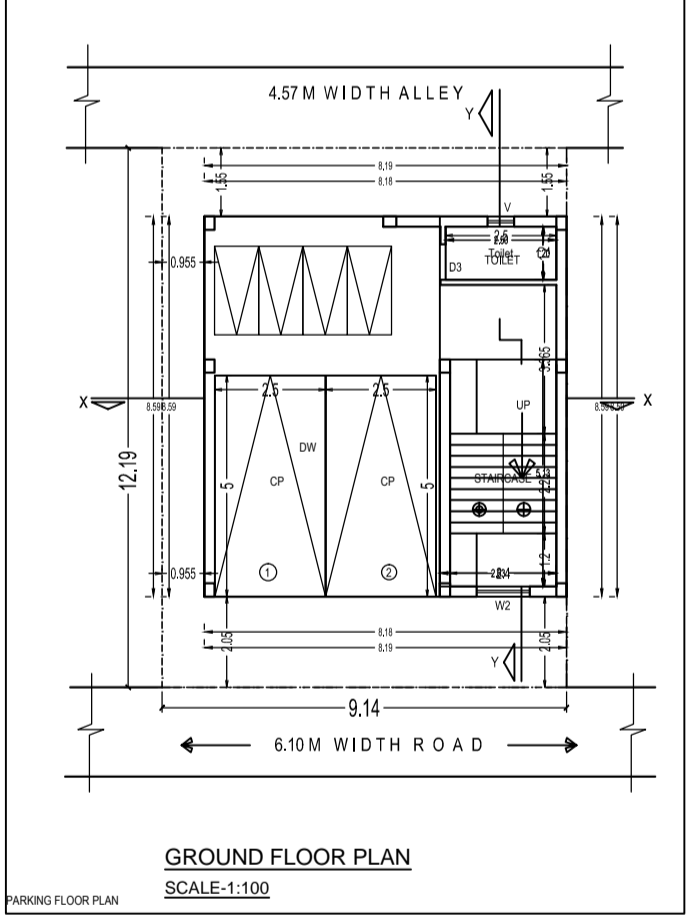
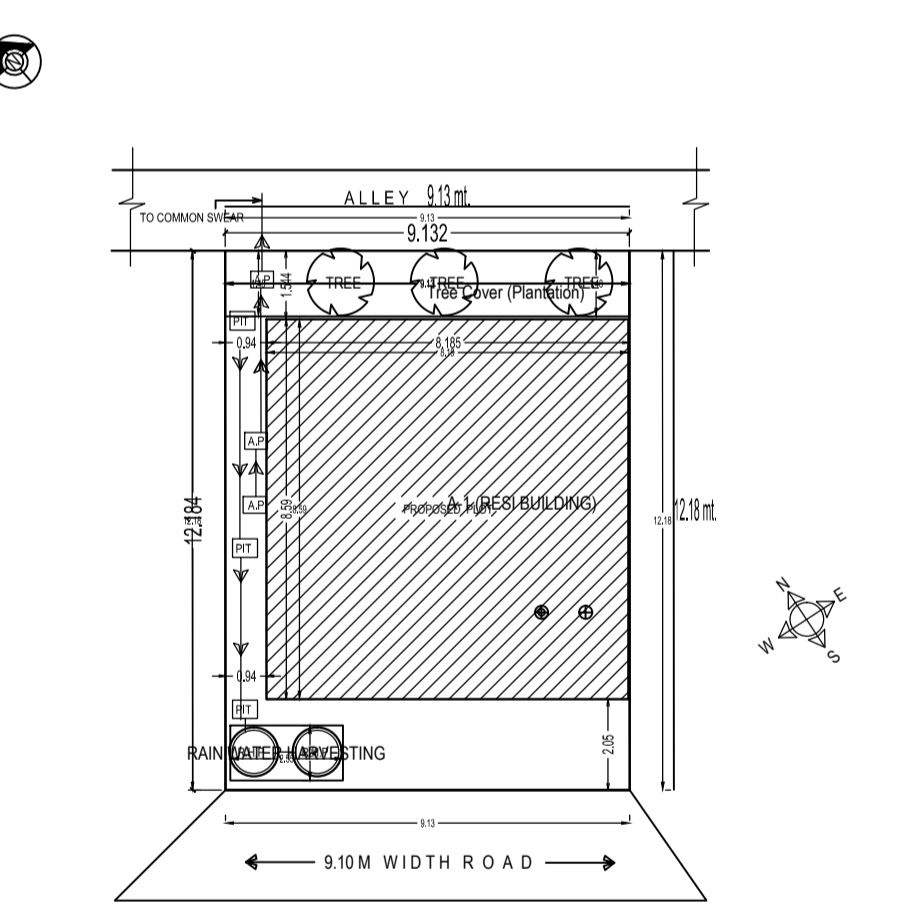

**Building A (RESI BUILDING)**

Floor Name	Total Built-up Area (Sq.mt)	Deductions (Area in Sq.mt)	Proposed FAR Area (Sq.mt)	Add Area in FAR (Sq.mt)	Total FAR Area (Sq.mt)	Tract No.
Parking	70.31	3.00	67.31	13.49	13.49	00
1st Floor	70.31	0.00	70.31	0.00	70.31	01
Second Floor	70.31	0.00	70.31	0.00	70.31	00
Roof	0.00	0.00	0.00	0.00	0.00	00
<b>Total</b>	<b>210.93</b>	<b>3.00</b>	<b>140.92</b>	<b>13.49</b>	<b>154.11</b>	<b>01</b>

**SCHEDULE OF JOINERY:**

BUILDING NAME	NAME	LENGTH	HEIGHT	NOS
A (RESI BUILDING)	53	2.75	2.15	36
A (RESI BUILDING)	52	0.50	2.25	12

**SCHEDULE OF JOINERY:**

BUILDING NAME	NAME	LENGTH	HEIGHT	NOS
A (RESI BUILDING)	53	0.50	1.20	14
A (RESI BUILDING)	54	0.50	1.20	14
A (RESI BUILDING)	52	1.25	1.20	24
A (RESI BUILDING)	51	1.50	1.20	24
<b>Total</b>				<b>56</b>

**UmsUA Table for Building A (RESI BUILDING)**

FLOOR	Name	UMSUA Type	UMSUA Area	Capitd Area	No. of Rooms	No. of Tenement
FIRST FLOOR	SPLIT A	FLAT	140.92	139.95	7	1
TOT	-	-	140.92	139.95	14	1