

Detail Of Plot Scale: (1:100)

Building :A (SRI G L MUKHERJEE AND OTHERS)

Floor Name	Total Built Up Area (Sq.mt.)	Deductions (Area in Sq.mt.)	Proposed FAR Area (Sq.mt.)	Add Area in FAR (Sq.mt.)	Total FAR Area (Sq.mt.)	Total Consumed Additional FAR Area (Sq.mt.)	Trmt (No.)
Ground Floor	112.23	10.87	84.17	0.00	17.19	17.19	00
First Floor	111.05	0.00	0.00	111.05	0.00	111.05	01
Second Floor	111.05	0.00	0.00	111.05	0.00	111.05	00
Terrace Floor	0.00	0.00	0.00	0.00	0.00	0.00	00
Total :	334.33	10.87	84.17	222.10	17.19	239.29	01
Total Number of Same Buildings	1						
Total :	334.33	10.87	84.17	222.10	17.19	239.29	01

SCHEDULE OF DOOR:

BUILDING NAME	NAME	LENGTH	HEIGHT	NOS
A (SRI G L MUKHERJEE AND OTHERS)	D2	0.75	2.13	08
A (SRI G L MUKHERJEE AND OTHERS)	D1	0.91	2.13	06
A (SRI G L MUKHERJEE AND OTHERS)	D	1.00	2.13	02

SCHEDULE OF WINDOW/VENTILATION:

BUILDING NAME	NAME	LENGTH	HEIGHT	NOS
A (SRI G L MUKHERJEE AND OTHERS)	V	0.60	2.70	04
A (SRI G L MUKHERJEE AND OTHERS)	W1	1.50	2.70	10
A (SRI G L MUKHERJEE AND OTHERS)	W2	1.50	2.70	02
A (SRI G L MUKHERJEE AND OTHERS)	W	2.50	2.70	02

UnitBUA Table for Building :A (SRI G L MUKHERJEE AND OTHERS)

FLOOR	Name	UnitBUA Type	UnitBUA Area	Carpet Area	No. of Rooms	No. of Tenement
SECOND FLOOR PLAN	SPLIT A	FLAT	0.00	0.00	8	0
FIRST FLOOR PLAN	SPLIT A	FLAT	167.04	166.73	8	1
Total:	-	-	167.04	166.73	16	1

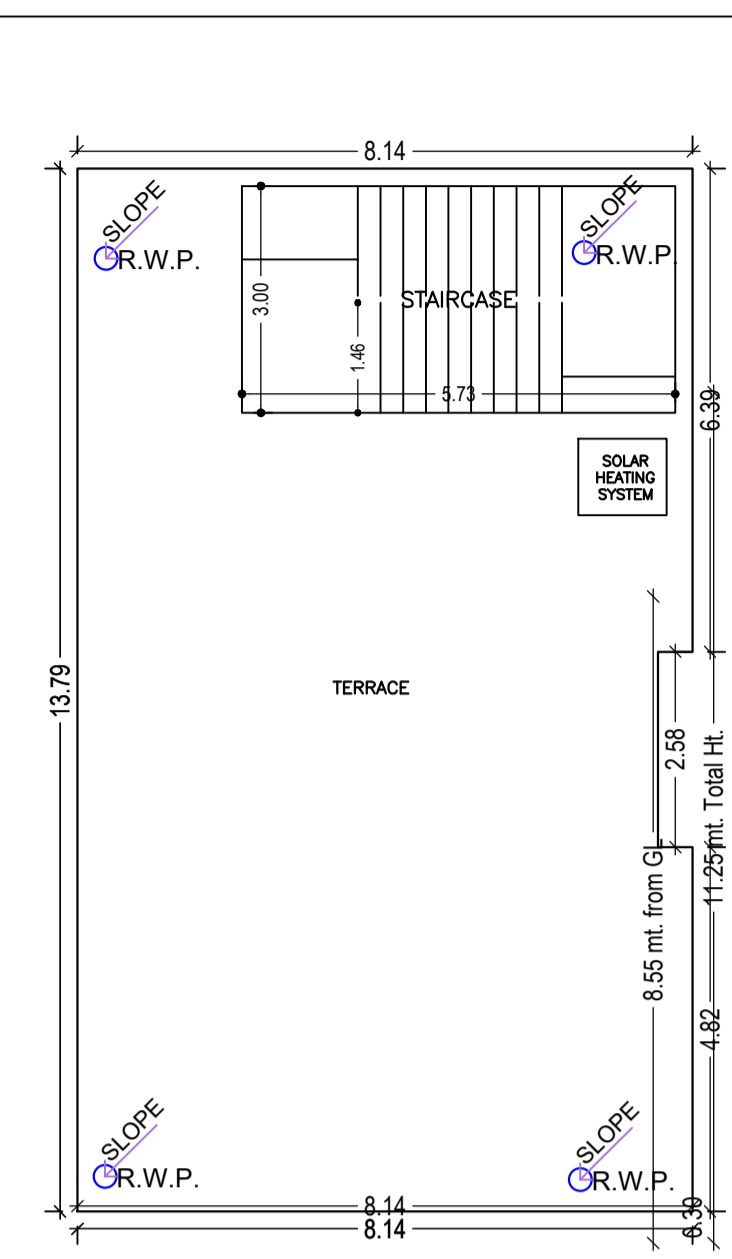

TERRACE FLOOR PLAN (SCALE 1:100)

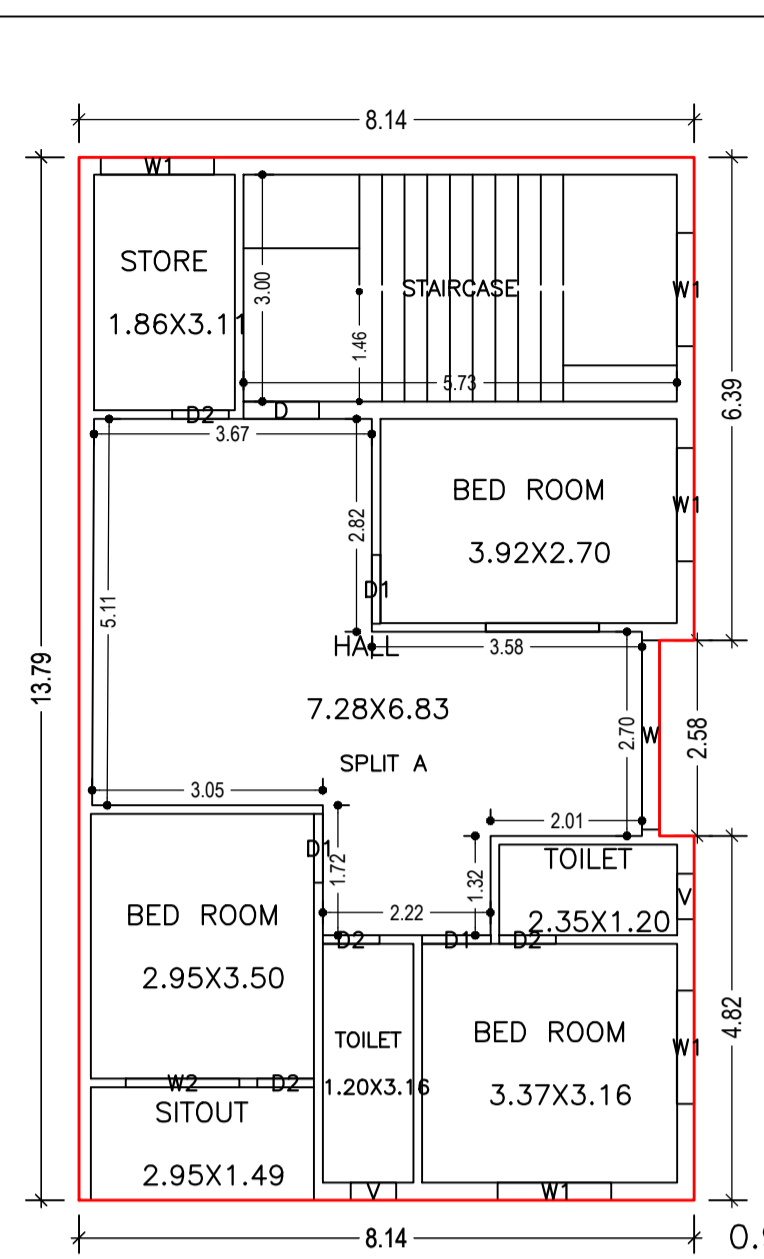

SECOND FLOOR PLAN (Proposed) (SCALE 1:100)

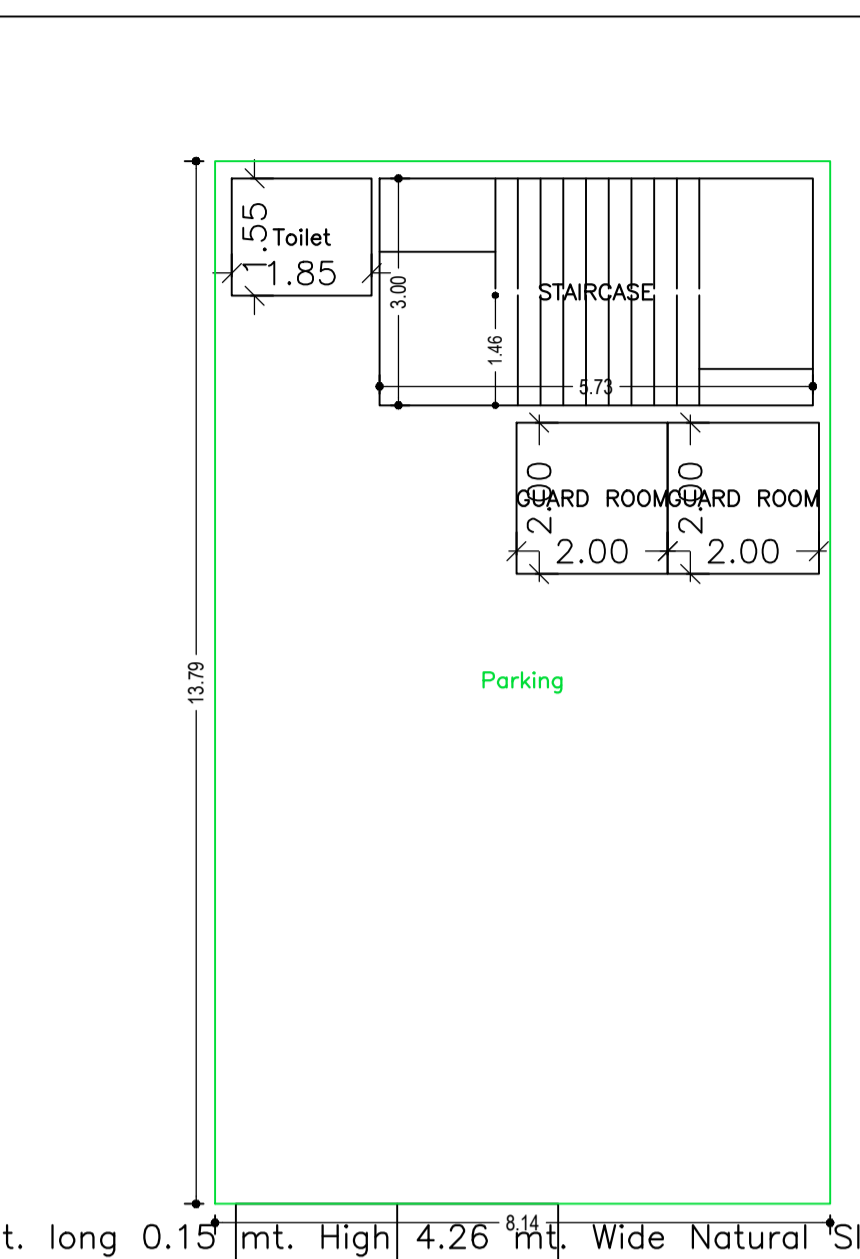

GROUND FLOOR PLAN (SCALE 1:100)

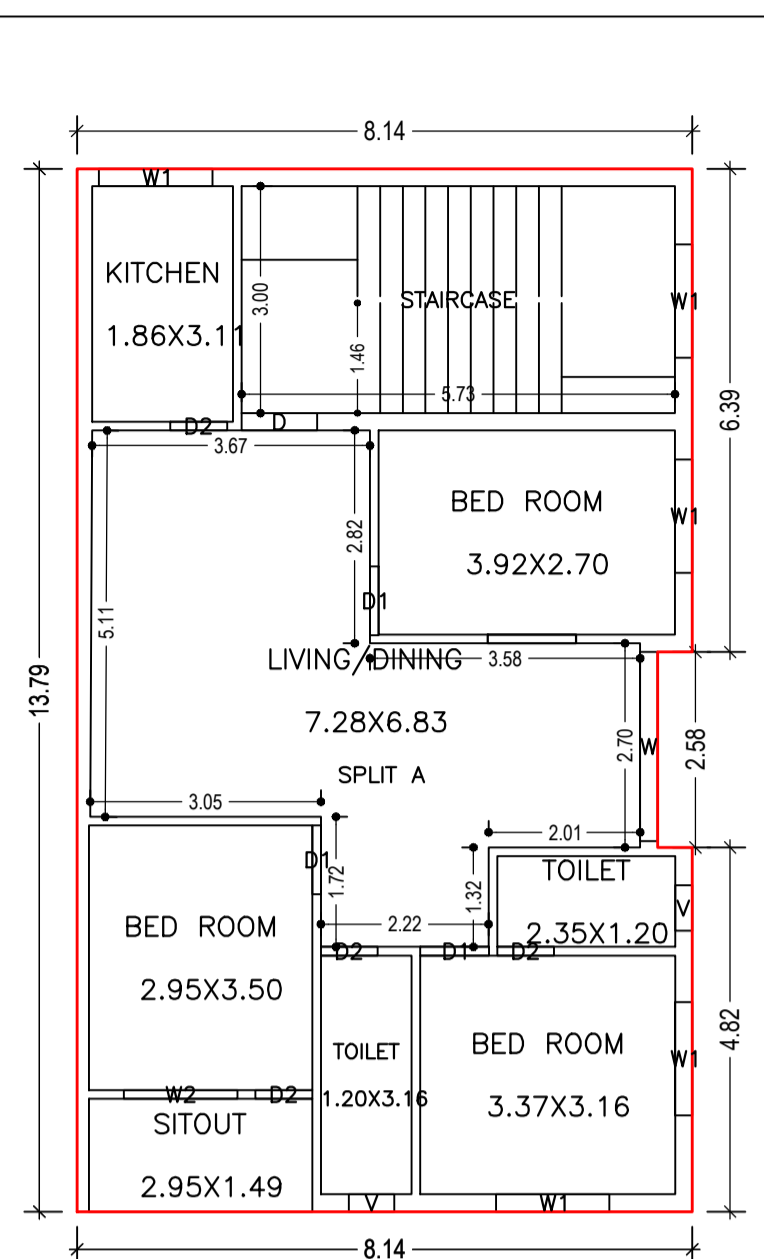

FIRST FLOOR PLAN (Proposed) (SCALE 1:100)

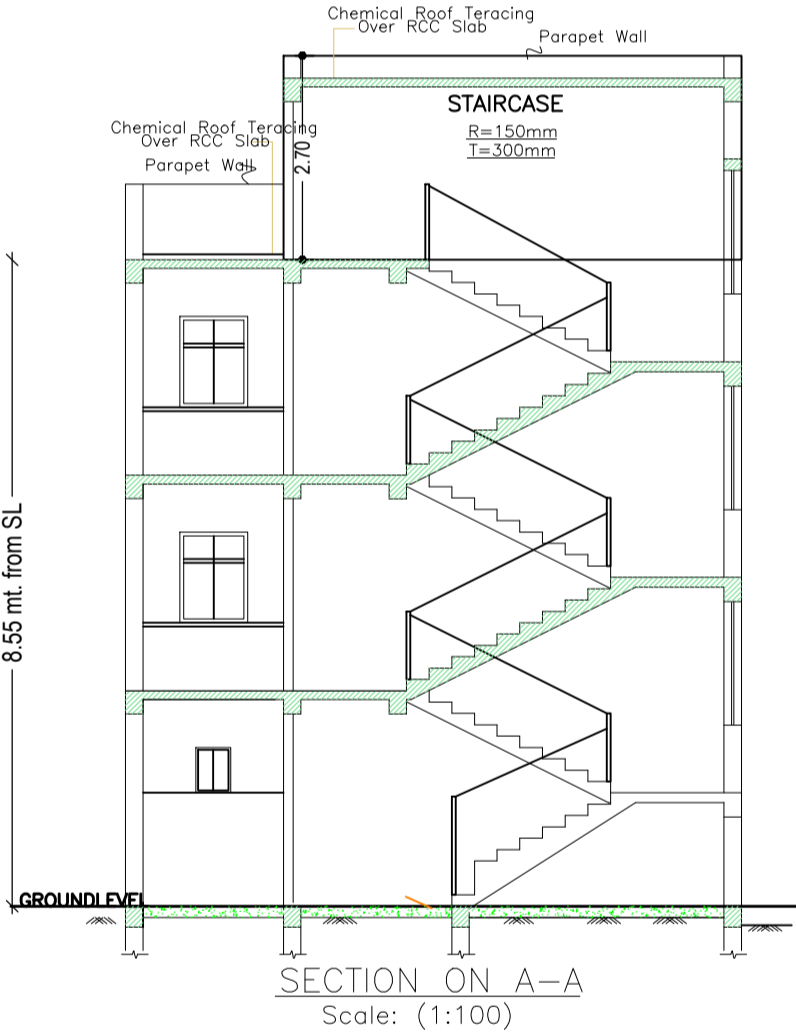

SECTION ON A-A Scale: (1:100)

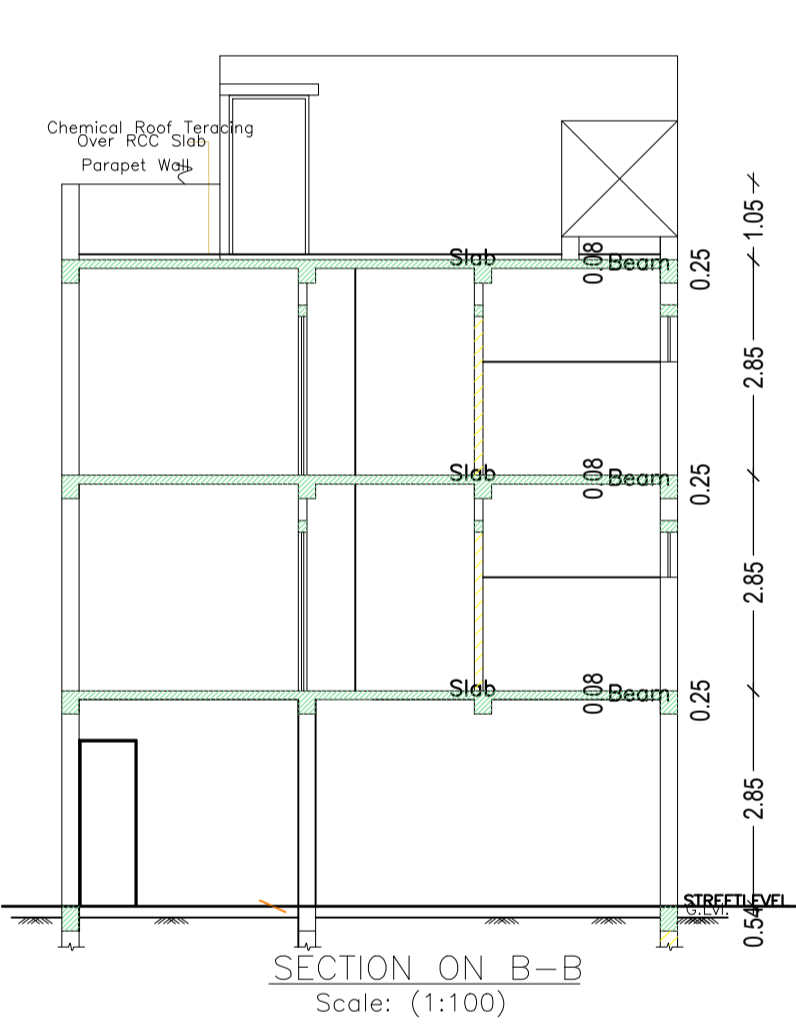

SECTION ON B-B Scale: (1:100)



FRONT ELEVATION Scale: (1:100)

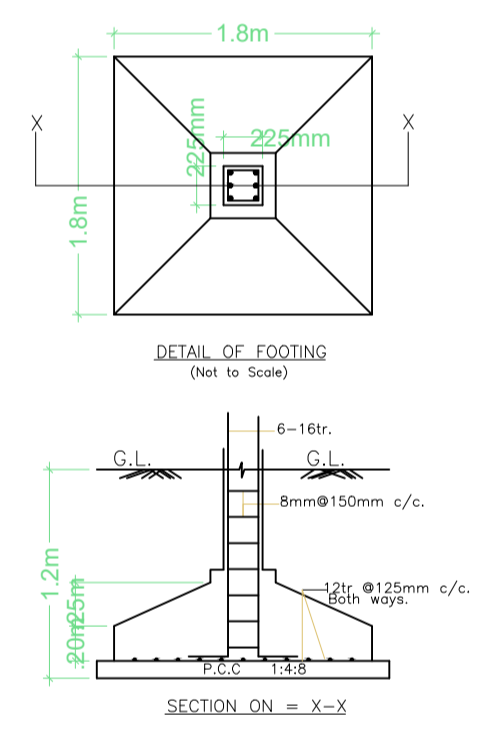

DETAIL OF FOOTING (Not to Scale)

SECTION ON X-X

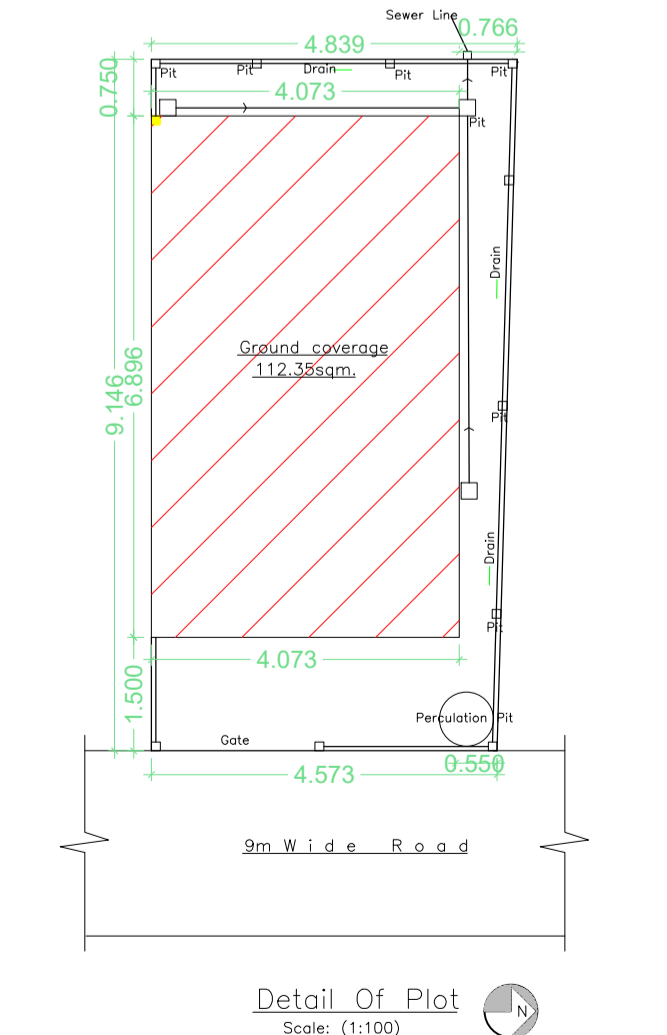

Detail Of Plot Scale: (1:100)



SIDE ELEVATION Scale: (1:100)

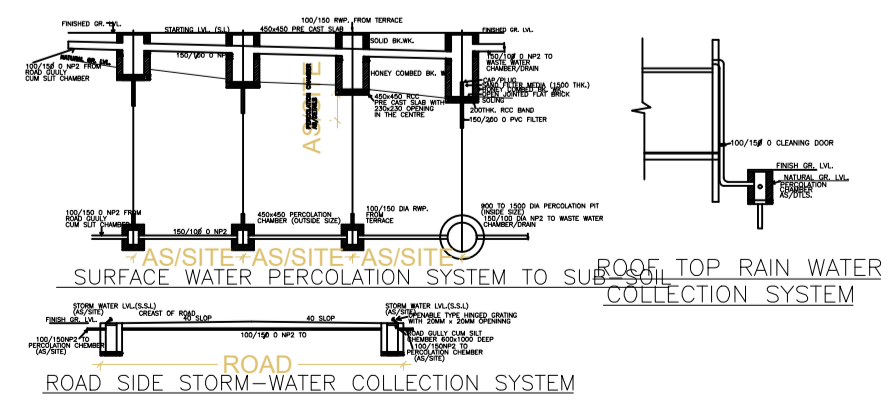

ROOF TOP RAIN WATER COLLECTION SYSTEM
ROAD SIDE STORM-WATER COLLECTION SYSTEM

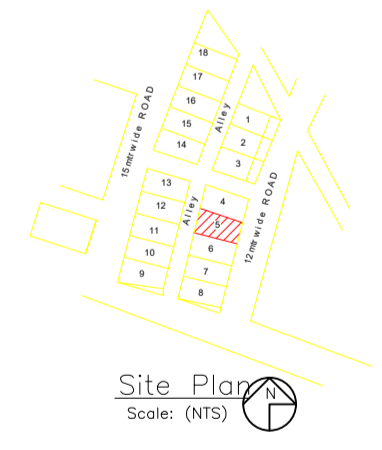

Site Plan Scale: (N15)

Proposal Basic Information

Proposal File No.	JNAC/BP/0112/W1/2023
Owner Name	SRI G L MUKHERJEE AND OTHERS
Khata No	H.NO-5
Plot No	H.NO-5
Village Name	SONARI
Use	Residential
SubUse	Bungalow/ Dwelling / Non Apartment

AREA STATEMENT	VERSION NO.: 1.0.66	
JAMSHEDPUR NAC	VERSION DATE: 16/10/2020	
PROJECT DETAIL:		
Region: JHARKHAND URBAN	Plot Use: Residential	
LOCAL BODIES:	Plot SubUse: Bungalow/ Dwelling / Non Apartment	
District: EAST SINGHBHUM	Plot/Nearby/Religious/Structure: NA	
Authority: JAMSHEDPUR NAC	Plot/SubPlot No: H.NO-5	
Inward No: JNAC/BP/0112/W1/2023	Plot/SubPlot No: H.NO-5	
Application Type: General Proposal	North: Road Width - 9.0 MTR WIDE MAIN ROAD	
Project Type: Building Permission	South: -	
Nature of Development: New	East: -	
Location of Development Area: Old Area	West: -	
AREA DETAILS:		
AREA OF PLOT (Minimum)	(A)	SQ.MT.
NET AREA OF PLOT(Gross Plot Area - Deduction from Gross Plot area)	(A-Deductions)	172.16
Deduction for Balance Plot Area(from Gross Plot Area)		
Common Plot		20.75
Total		20.75
BALANCE AREA OF PLOT(Net Plot Area - Recreational/Amenity space)	(A-Deductions)	151.40
PLOT AREA FOR COVERAGE(Net Plot Area)	(A-Deductions)	172.16
Plot Area for FAR (Net Plot Area + Road Widening Area)	(A-Deductions)	172.16
COVERAGE CHECK		
Permissible Coverage area (70.00 %)		120.51
Proposed Coverage Area (65.19 %)		112.23
Total Prop. Coverage Area (65.19 %)		112.23
Balance coverage area (4.81 %)		8.28
FAR CHECK		
Perm. FAR Area (2.500)		430.40
Total Perm. FAR area		430.40
Residential FAR		222.09
Proposed FAR Area		239.29
Total Proposed FAR Area		239.29
Consumed FAR (Factor)		1.39
Balance FAR Area		191.11
BUILT UP AREA CHECK		
Total Proposed BuiltUp Area		334.33
ARCHITECT (Regd)		
ARCHITECT (Regd)	Amarjeet Balmuchu	
ENGINEER (Regd)		
ENGINEER (Regd)		
SUPERVISOR (Regd)		
SUPERVISOR (Regd)		
OWNER (Regd)		
OWNER (Regd)	SRI G L MUKHERJEE AND OTHERS	
DEVELOPMENT AUTHORITY		
DEVELOPMENT AUTHORITY	LOCAL BODY	

COLOR INDEX

PLOT BOUNDARY	Black
ABUTTING ROAD	Red
PROPOSED CONSTRUCTION	Green
COMMON PLOT	Yellow
ROAD WIDENING AREA	Blue
EXISTING (To be retained)	Orange
EXISTING (To be demolished)	Light Blue

Buildingwise Floor FAR Details

Floor Name	Building Name		Total	
	Proposed Built Up Area (Sq.mt.)	Proposed FAR Area (Sq.mt.)	Total Proposed Built Up Area (Sq.mt.)	Total FAR Area (Sq.mt.)
Ground Floor	112.23	17.19	112.23	17.19
First Floor	111.05	111.05	111.05	111.05
Second Floor	111.05	111.05	111.05	111.05
Terrace Floor	0.00	0.00	0.00	0.00
Total :	334.33	239.29	334.33	239.29

Building USE/SUBUSE Details

Building Name	Building Use	Building SubUse	Building Structure
A (SRI G L MUKHERJEE AND OTHERS)	Residential	Bungalow/ Dwelling / Non Apartment	Non-Highrise

FAR & Tenement Details (Table 4c-1)

Building	No. of Same Bldg	Total Built Up Area (Sq.mt.)	Deductions (Area in Sq.mt.)	Proposed FAR Area (Sq.mt.)	Add Area in FAR (Sq.mt.)	Total FAR Area (Sq.mt.)	Total Consumed Additional FAR Area (Sq.mt.)	Trmt (No.)
A (SRI G L MUKHERJEE AND OTHERS)	1	334.33	10.87	84.17	222.10	17.19	239.29	01
Grand Total :	1	334.33	10.87	84.17	222.10	17.19	239.29	01

LTP NAME AND SIGNATURE	STRUCTURAL ENG'S NAME AND SIGNATURE	BUILDER NAME AND SIGNATURE	DIGITAL SIGNATURE
Amarjeet Balmuchu JNAC/ARC/0008/2018			