

Project Title :SRI G L MUKHERJEE AND OTHERS

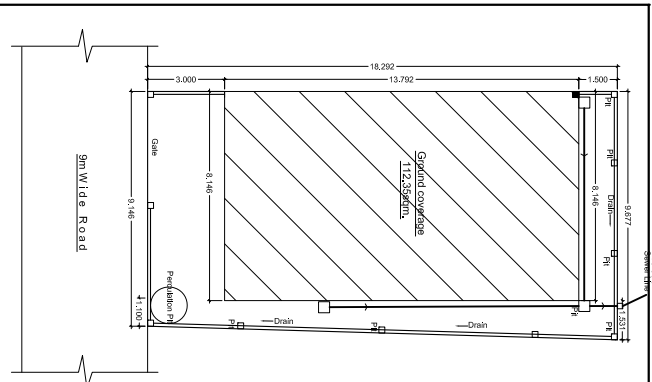

PARTICULARS	EXISTING	PROPOSED	TOTAL
PLOT AREA	172.146 Sqm	172.146 Sqm	172.146 Sqm
COVERED AREA	-	-	-
BASEMENT	-	-	-
GROUND FLOOR	-	36.34 Sqm	36.34 Sqm
1ST FLOOR	-	112.35 Sqm	112.35 Sqm
2ND FLOOR	-	112.35 Sqm	112.35 Sqm
TOTAL	-	261.04 Sqm	261.04 Sqm

PLOT AREA = 172.146 Sqm
 % GROUND COVERAGE = 64.39 %
 F. A. R. = 1.496

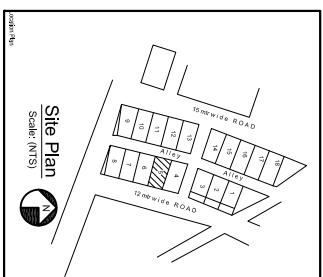
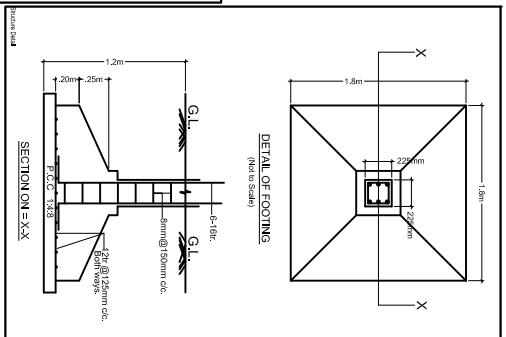
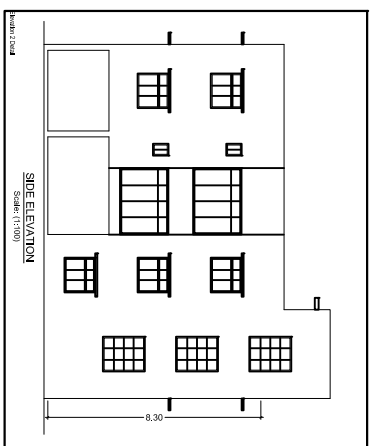
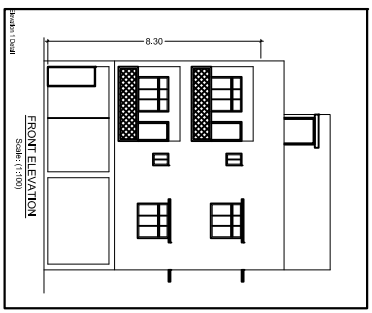
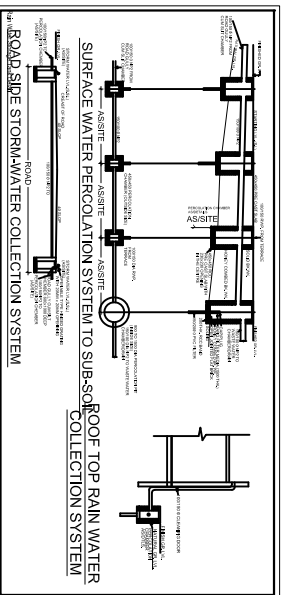
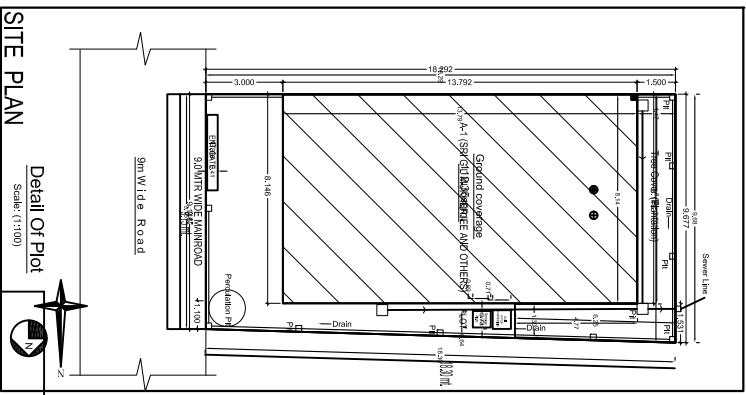
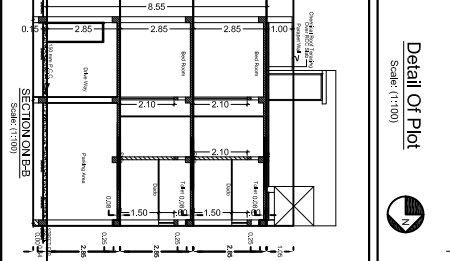
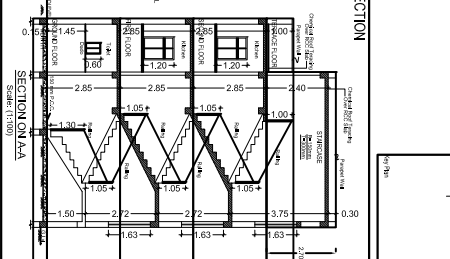
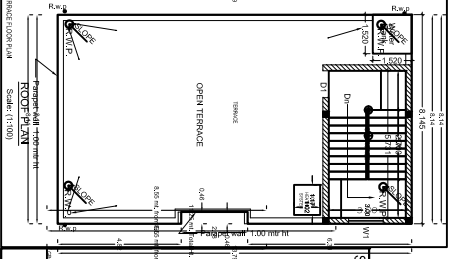
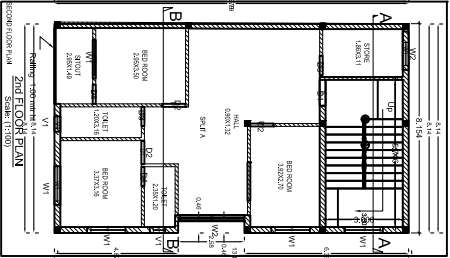
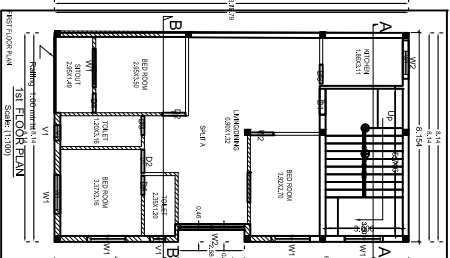
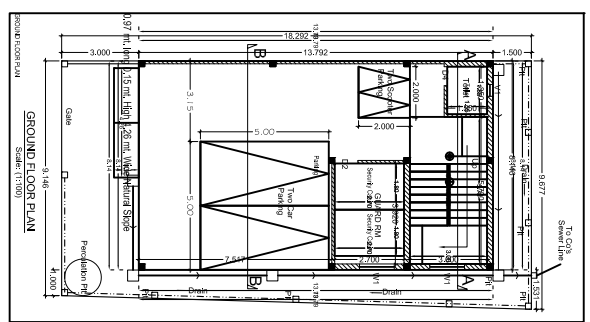

Building A (SRI G. L. MUKHERJEE AND OTHERS)

Building A (SRI G. L. MUKHERJEE AND OTHERS)

Sl. No.	Particulars	Area (Sq. M)	Volume (Cu. M)	Weight (Tons)
1	Concrete	112.35	112.35	112.35
2	Brickwork	112.35	112.35	112.35
3	Plaster	112.35	112.35	112.35
4	Roofing	112.35	112.35	112.35
5	Painting	112.35	112.35	112.35
6	Electrical	112.35	112.35	112.35
7	Waterproofing	112.35	112.35	112.35
8	Sanitary	112.35	112.35	112.35
9	Other	112.35	112.35	112.35
10	Total	112.35	112.35	112.35

Sl. No.	Particulars	Area (Sq. M)	Volume (Cu. M)	Weight (Tons)
1	Concrete	112.35	112.35	112.35
2	Brickwork	112.35	112.35	112.35
3	Plaster	112.35	112.35	112.35
4	Roofing	112.35	112.35	112.35
5	Painting	112.35	112.35	112.35
6	Electrical	112.35	112.35	112.35
7	Waterproofing	112.35	112.35	112.35
8	Sanitary	112.35	112.35	112.35
9	Other	112.35	112.35	112.35
10	Total	112.35	112.35	112.35

Sl. No.	Particulars	Area (Sq. M)	Volume (Cu. M)	Weight (Tons)
1	Concrete	112.35	112.35	112.35
2	Brickwork	112.35	112.35	112.35
3	Plaster	112.35	112.35	112.35
4	Roofing	112.35	112.35	112.35
5	Painting	112.35	112.35	112.35
6	Electrical	112.35	112.35	112.35
7	Waterproofing	112.35	112.35	112.35
8	Sanitary	112.35	112.35	112.35
9	Other	112.35	112.35	112.35
10	Total	112.35	112.35	112.35

ARCHITECTURAL SPECIFICATIONS :-

- Foundation - 1:1.50 Cement conc. for footing over R.C.C. mat of 1:4:8
- Superstructure - 1:1.5:3: RCC Column with 16 cement brick work over 112 mm thick RCC slab.
- Roofing - 25 mm thick IP 8 roofing cover 100 mm thick PCC & over 112 mm thick RCC slab.
- Plaster - 12 mm to 18 mm thick cement plaster with 16 cement mortar.
- Doors - D1+1.05 m x 2.13 m, D2+0.91 m x 2.13 m, D3+0.84 m x 2.13 m, D4+0.76 m x 2.22 m.
- Windows - W1+1.37 m x 1.22 m, W2+1.51 m x 1.22 m.
- Ventilators - V1+0.60 m x 0.60 m.

CALCULATION FOR OVER HEAD TANK

2 FLATS = 1 x 5 = 10 PERSON @ 200 Lt. / DAY PERSON = 2000 Lt. 1 Nos. Tank Size = 1.37m x 1.52 m x 1.52 m = 3.16 Cum.

AREA STATEMENT :-
 PLOT AREA :- 172.146 Sqm
 GR. FLOOR AREA :- 36.34 Sqm
 1ST FLOOR AREA :- 112.35 Sqm
 2ND FLOOR AREA :- 112.35 Sqm

PROPOSED RESIDENTIAL BUILDING PLAN OF SRI G L MUKHERJEE AND OTHERS

HOLDING NO.-5 SONARY WEST NEW LAYOUT AREA, SONARY Sonary, Jamshedpur.

OWNER / POWER OF ATTORNEY HOLDER.

CONSULTANT:-

Sl. No.	Particulars	Area (Sq. M)	Volume (Cu. M)	Weight (Tons)
1	Concrete	112.35	112.35	112.35
2	Brickwork	112.35	112.35	112.35
3	Plaster	112.35	112.35	112.35
4	Roofing	112.35	112.35	112.35
5	Painting	112.35	112.35	112.35
6	Electrical	112.35	112.35	112.35
7	Waterproofing	112.35	112.35	112.35
8	Sanitary	112.35	112.35	112.35
9	Other	112.35	112.35	112.35
10	Total	112.35	112.35	112.35

Sl. No.	Particulars	Area (Sq. M)	Volume (Cu. M)	Weight (Tons)
1	Concrete	112.35	112.35	112.35
2	Brickwork	112.35	112.35	112.35
3	Plaster	112.35	112.35	112.35
4	Roofing	112.35	112.35	112.35
5	Painting	112.35	112.35	112.35
6	Electrical	112.35	112.35	112.35
7	Waterproofing	112.35	112.35	112.35
8	Sanitary	112.35	112.35	112.35
9	Other	112.35	112.35	112.35
10	Total	112.35	112.35	112.35

Sl. No.	Particulars	Area (Sq. M)	Volume (Cu. M)	Weight (Tons)
1	Concrete	112.35	112.35	112.35
2	Brickwork	112.35	112.35	112.35
3	Plaster	112.35	112.35	112.35
4	Roofing	112.35	112.35	112.35
5	Painting	112.35	112.35	112.35
6	Electrical	112.35	112.35	112.35
7	Waterproofing	112.35	112.35	112.35
8	Sanitary	112.35	112.35	112.35
9	Other	112.35	112.35	112.35
10	Total	112.35	112.35	112.35