

Proposal Basic Information

Proposal File No.	JNAC/BP/0074/W2/2023
Owner Name	SRI BINAY KUMAR SINGH
Khata No	22 (OLD) , 49 (NEW)
Plot No	1298 (OLD) , 2434 (NEW)
Village Name	BHATIA
Use	Residential
SubUse	Residential Bldg/Apartment

AREA STATEMENT JAMSHEDPUR NAC

VERSION NO.	1.0.68
VERSION DATE	16/10/2020
PROJECT DETAIL:	
Region - JHARKHAND URBAN LOCAL BODIES	Plot Use: Residential
District - EAST SINGHBHUM	Plot SubUse: Residential Bldg/Apartment
Authority - JAMSHEDPUR NAC	PlotNearby/ReligiousStructure: NA
Inward_No - JNAC/BP/0074/W2/2023	Plot/SubPlot No: 1298 (OLD) , 2434 (NEW)
Application Type: General Proposal	North: Plot No. - SMT PUNAM DEVI
Project Type: Building Permission	South: Plot No. - NU LAND
Nature of Development: New	East: Road Width - 4.57
Location of Development Area: Old Area	West: Plot No. - SMT. SUJATA GHOSH

AREA DETAILS:

AREA OF PLOT (Minimum)	(A)	SQ.MT.	137.18
Deduction for NetPlot Area			
Surrender Free of Cost			9.05
Total			9.05
NET AREA OF PLOT(Gross Plot Area - Deduction from Gross Plot area)	(A-Deductions)		128.13
Deduction for Balance Plot Area(from Gross Plot Area)			
Surrender Free of Cost			9.05
Common Plot			24.37
Total			33.42
BALANCE AREA OF PLOT(Net Plot Area - Recreational/Amenity space)	(A-Deductions)		103.76
PLOT AREA FOR COVERAGE(Net Plot Area)	(A-Deductions)		128.13
Plot Area for FAR (Net Plot Area + RoadWidening Area)	(A-Deductions)		137.18

COVERAGE CHECK

Permissible Coverage area (70.00 %)	89.69
Proposed Coverage Area (56.77 %)	72.74
Total Prop. Coverage Area (56.77 %)	72.74
Balance coverage area (13.23 %)	

FAR CHECK

Perm. FAR Area (1.500)	205.77
Proposed FAR Area	145.47
Total Proposed FAR Area	155.13
Consumed FAR (Factor)	1.13
Built Up Area	50.64

BUILT UP AREA CHECK

Total Proposed BuiltUp Area	218.22
-----------------------------	--------

ARCHITECT (Regd) SATISH KUMAR
ENGINEER (Regd)
SUPERVISOR (Regd)
OWNER (Regd) SRI BINAY KUMAR SINGH

COLOR INDEX

PLOT BOUNDARY	Black
ABUTTING ROAD	Green
PROPOSED CONSTRUCTION	Red
COMMON PLOT	Yellow
ROAD WIDENING AREA	Blue
EXISTING (To be retained)	Orange
EXISTING (To be demolished)	Grey

Buildingwise Floor FAR Details

Floor Name	Building Name		Total	
	Proposed Built Up Area (Sq.mt.)	Proposed FAR Area (Sq.mt.)	Total Proposed Built Up Area (Sq.mt.)	Total FAR Area (Sq.mt.)
Ground Floor	72.74	9.66	72.74	9.66
First Floor	72.74	72.74	72.74	72.74
Second Floor	72.74	72.74	72.74	72.74
Terrace Floor	0.00	0.00	0.00	0.00
Total :	218.22	155.14	218.22	155.14

Building USE/SUBUSE Details

Building Name	Building Use	Building SubUse	Building Structure
BK (SINGH)	Residential	Other Residential Building	Non-Highrise

FAR & Tenement Details (Table 4c-1)

Building	No. of Same Bldg	Total Built Up Area (Sq.mt.)	Deductions (Area in Sq.mt.)			Proposed FAR Area (Sq.mt.)	Add Area In FAR (Sq.mt.)	Total FAR Area (Sq.mt.)	Total Consumed FAR Area (Sq.mt.)	Trmt (No.)
			Parking	Resi.	Stair					
BK (SINGH)	1	218.22	63.08	145.48	9.66	155.14	155.14	01		
Grand Total :	1	218.22	63.08	145.48	9.66	155.14	155.14	01		

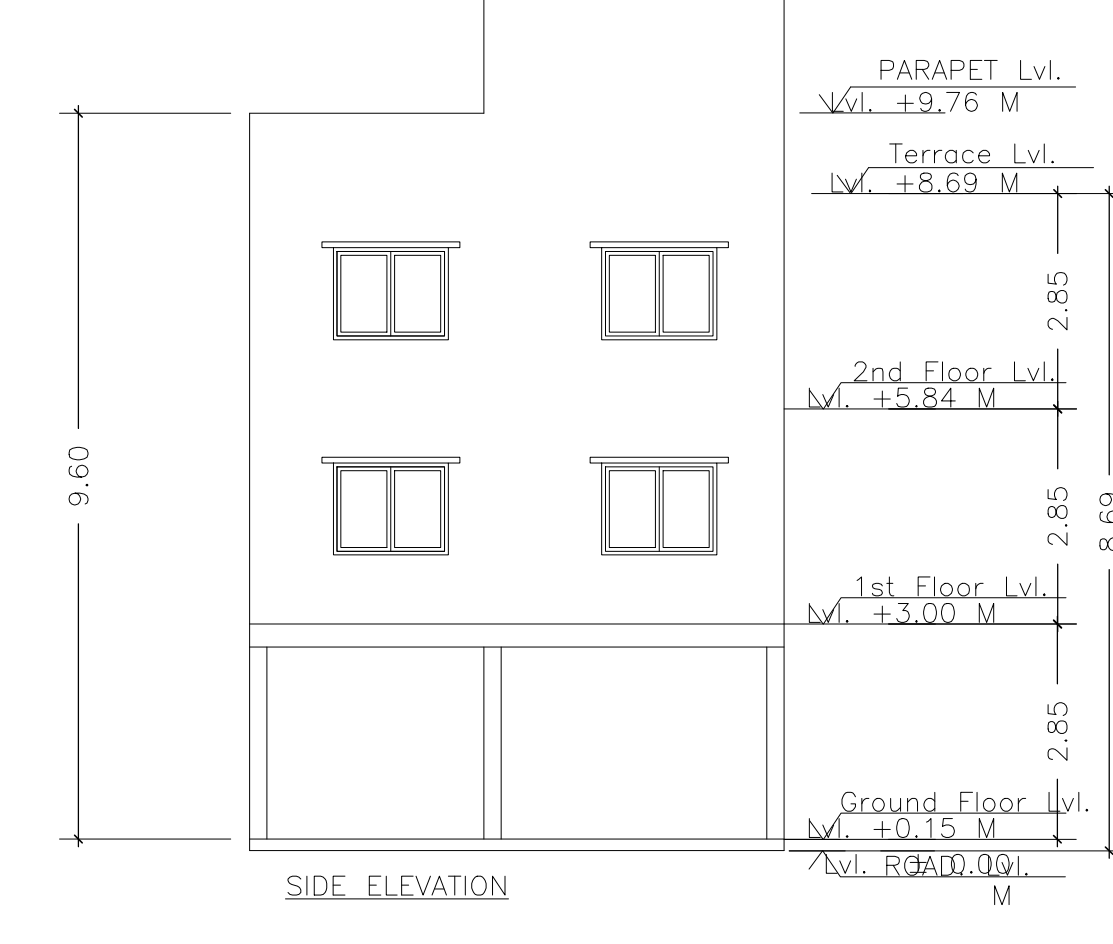
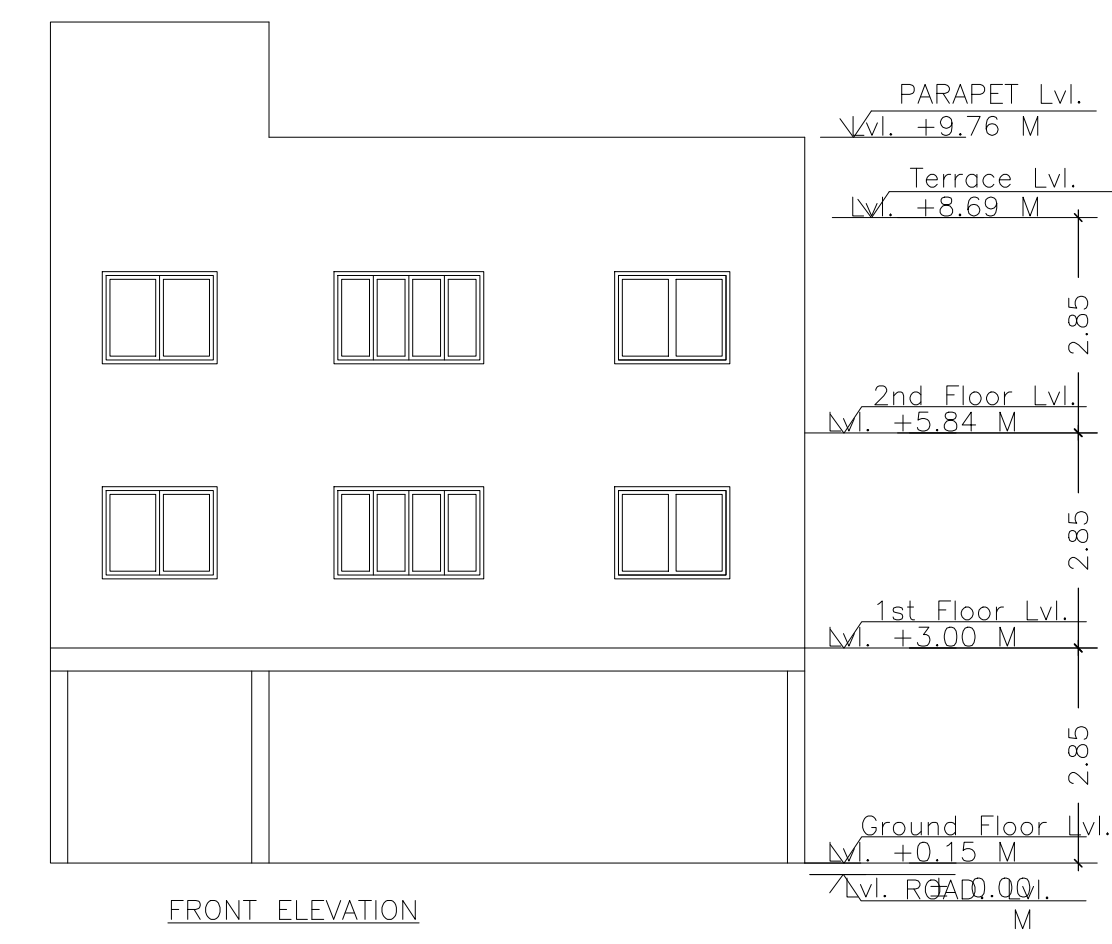
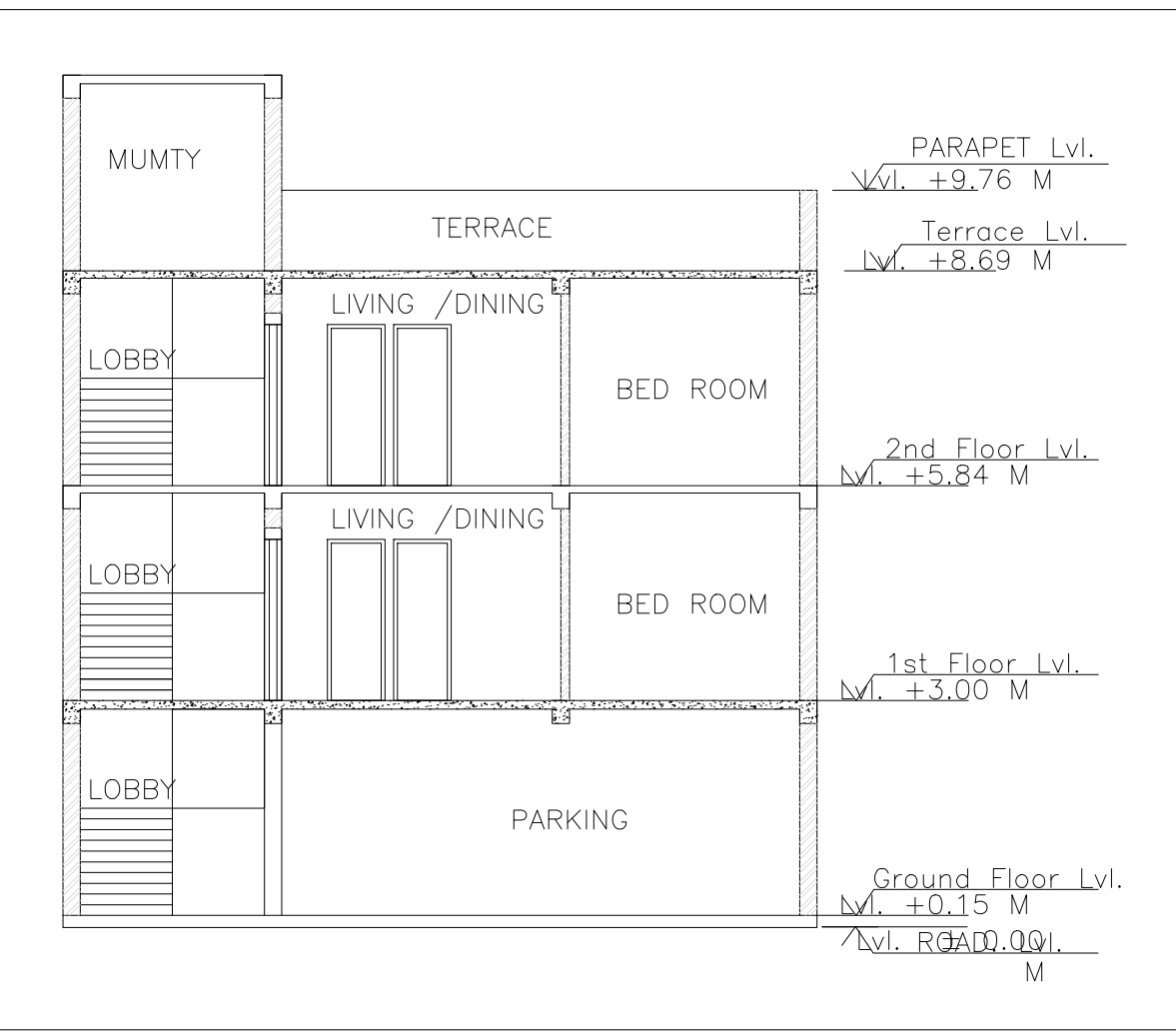
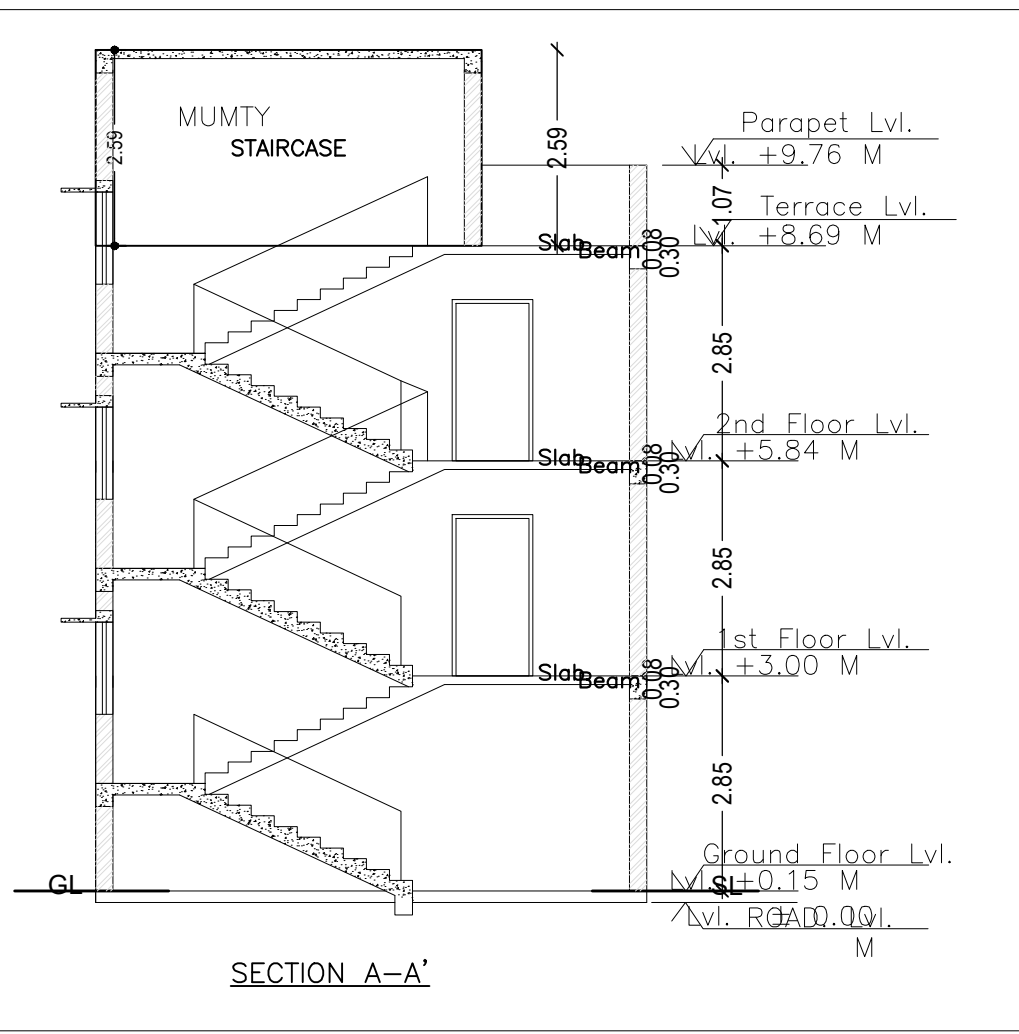
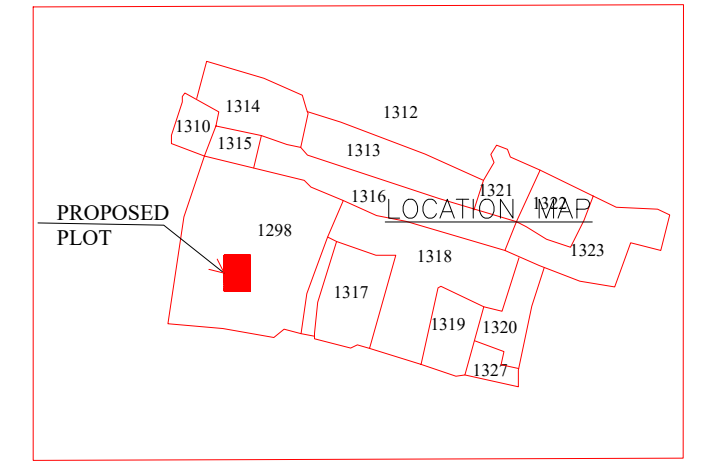
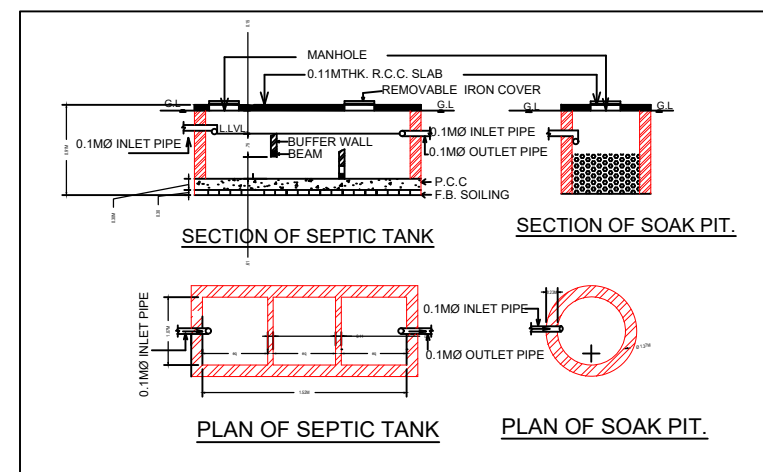
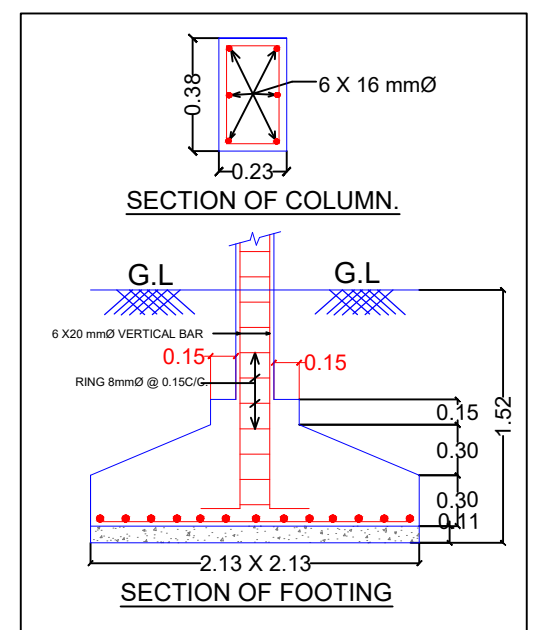

LTP NAME AND SIGNATURE	STRUCTURAL ENG'S NAME AND SIGNATURE	BUILDER NAME AND SIGNATURE	DIGITAL SIGNATURE
SATISH KUMAR JNAC/DFT/MN/0004/2017			